

IDAHO ADMINISTRATIVE BULLETIN

October 2, 2024 – Vol. 24-10

Office of the Governor
Division of Financial Management
Office of the Administrative Rules Coordinator

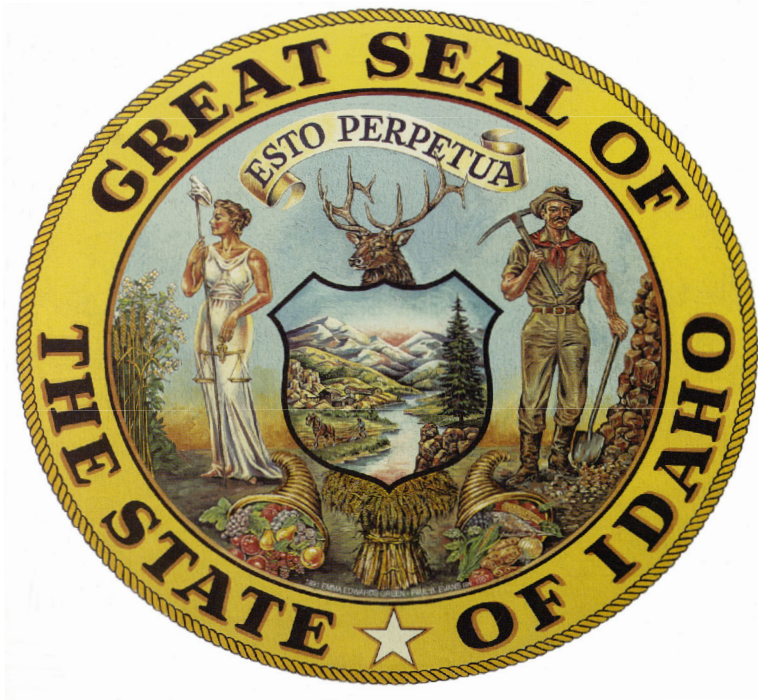

The Idaho Administrative Bulletin is published monthly by the Office of the Administrative Rules Coordinator, Division of Financial Management, Office of the Governor, pursuant to Title 67, Chapter 52, Idaho Code.

Brad Little, Governor
Lori Wolff, Administrator, Division of Financial Management
Josh Scholer, Deputy General Counsel
Bradley A. Hunt, Administrative Rules Coordinator
Logan P. Medel, Administrative Rules Specialist
Margaret Major, Desktop Publishing Specialist
All Rights Reserved / Printed in the United States of America

IDAHO ADMINISTRATIVE BULLETIN

Table of Contents

October 2, 2024 – Vol. 24-10

PREFACE	8
IDAPA 02 – IDAHO STATE DEPARTMENT OF AGRICULTURE	
02.02.12 – <i>Bonded Warehouse Rules</i> Docket No. 02-0212-2401 (ZBR Chapter Rewrite) Notice of Rulemaking – Proposed Rule	15
02.02.14 – <i>Rules for Weights and Measures</i> Docket No. 02-0214-2401 Notice of Rulemaking – Proposed Rule	26
02.03.01 – <i>Rules Governing Pesticide Management Plans for Ground Water Protection</i> Docket No. 02-0301-2401 (ZBR Chapter Rewrite) Notice of Rulemaking – Proposed Rule	29
02.04.03 – <i>Rules Governing Animal Industry</i> Docket No. 02-0403-2401 (ZBR Chapter Rewrite) Notice of Rulemaking – Proposed Rule	40
02.04.05 – <i>Rules Governing Grade A Milk and Manufacture Grade Milk</i> Docket No. 02-0405-2401 Notice of Rulemaking – Proposed Rule	61
02.04.15 – <i>Rules Governing Beef Cattle Animal Feeding Operations</i> Docket No. 02-0415-2401 Notice of Rulemaking – Proposed Rule	64
02.04.19 – <i>Rules Governing Domestic Cervidae</i> Docket No. 02-0419-2401 Notice of Rulemaking – Proposed Rule	69
02.05.01 – <i>Rules Governing Produce Safety</i> Docket No. 02-0501-2401 (ZBR Chapter Rewrite) Notice of Rulemaking – Proposed Rule	76
02.06.02 – <i>Rules Governing Registrations and Licenses</i> Docket No. 02-0602-2401 Notice of Rulemaking – Proposed Rule	80
02.06.09 – <i>Rules Governing Invasive Species and Noxious Weeds</i> Docket No. 02-0609-2402 Notice of Rulemaking – Proposed Rule	83
Docket No. 02-0609-2404 Notice of Rulemaking – Adoption of Temporary Rule	89
02.06.33 – <i>Organic Food Products Rules</i> Docket No. 02-0633-2401 Notice of Rulemaking – Proposed Rule	91

IDAPA 02.08 – IDAHO SHEEP AND GOAT HEALTH BOARD*02.08.01 – Sheep and Goat Rules of the Idaho Sheep and Goat Health Board****Docket No. 02-0801-2401 (ZBR Chapter Rewrite)***

Notice of Rulemaking – Proposed Rule93

IDAPA 08 – STATE BOARD OF EDUCATION*08.01.13 – Rules Governing the Opportunity Scholarship Program****Docket No. 08-0113-2401***

Notice of Rulemaking – Proposed Rule105

*08.02.02 – Rules Governing Uniformity****Docket No. 08-0202-2401***

Notice of Rulemaking – Proposed Rule110

*08.02.03 – Rules Governing Thoroughness****Docket No. 08-0203-2401***

Notice of Rulemaking – Proposed Rule126

Docket No. 08-0203-2403

Notice of Rulemaking – Adoption of Temporary Rule.....138

*08.04.01 – Rules of the Idaho Digital Learning Academy****Docket No. 08-0401-2401***

Notice of Rulemaking – Proposed Rule145

IDAPA 09 – IDAHO DEPARTMENT OF LABOR*09.01.01 – Rules of Administrative Procedure of the Department of Labor****Docket No. 09-0101-2401 (ZBR Chapter Rewrite)***

Notice of Rulemaking – Proposed Rule147

*09.01.30 – Unemployment Insurance Benefits Administration Rules****Docket No. 09-0130-2401 (ZBR Chapter Rewrite)***

Notice of Rulemaking – Proposed Rule154

*09.01.35 – Unemployment Insurance Tax Administration Rules****Docket No. 09-0135-2401 (ZBR Chapter Rewrite)***

Notice of Rulemaking – Proposed Rule175

IDAPA 11 – IDAHO STATE POLICE / STATE FORENSIC LABORATORY*11.03.01 – Rules Governing Alcohol Testing****Docket No. 11-0301-2401 (ZBR Chapter Rewrite)***

Notice of Rulemaking – Proposed Rule191

*11.11.01 – Rules of the Idaho Peace Officer Standards and Training Council****Docket No. 11-1101-2401***

Notice of Rulemaking – Adoption of Pending Rule200

IDAPA 13 – IDAHO DEPARTMENT OF FISH AND GAME*13.01.02 – Rules Governing Mandatory Education, Mentored Hunting, and Shooting Ranges****Docket No. 13-0102-2401***

Notice of Rulemaking – Temporary and Proposed Rule.....201

*13.01.07 – Rules Governing Taking of Wildlife****Docket No. 13-0107-2401***

Notice of Rulemaking – Proposed Rule203

13.01.11 – *Rules Governing Fish*
Docket No. 13-0111-2401
 Notice of Rulemaking – Proposed Rule206

13.01.17 – *Rules Governing Use of Bait for Hunting Big Game Animals*
Docket No. 13-0117-2402
 Notice of Rulemaking – Adoption of Temporary Rule209

IDAPA 16 – DEPARTMENT OF HEALTH AND WELFARE

16.02.13 – *State of Idaho Drinking Water Laboratory Certification Program*
Docket No. 16-0213-2401 (ZBR Chapter Rewrite, Fee Rule)
 Notice of Public Hearing and Extension of Written Comment Period211

IDAPA 17 – INDUSTRIAL COMMISSION

17.01.01 – *Administrative Rules Under the Worker's Compensation Law*
Docket No. 17-0101-2301 (ZBR Chapter Rewrite)
 Notice of Rulemaking – Proposed Rule212

IDAPA 20 – IDAHO DEPARTMENT OF LANDS

20.03.13 – *Administration of Cottage Site Leases on State Lands*
Docket No. 20-0313-2401 (ZBR Chapter Rewrite)
 Notice of Rulemaking – Adoption of Pending Rule245

20.03.14 – *Rules Governing Grazing, Farming, and Conservation Leases*
Docket No. 20-0314-2401 (ZBR Chapter Rewrite)
 Notice of Rulemaking – Adoption of Pending Rule246

20.03.15 – *Rules Governing Geothermal Leasing on Idaho State Lands*
Docket No. 20-0315-2401 (ZBR Chapter Rewrite, Fee Rule)
 Notice of Rulemaking – Adoption of Pending Rule247

20.03.16 – *Rules Governing Oil and Gas Leasing on Idaho State Lands*
Docket No. 20-0316-2401 (ZBR Chapter Rewrite, Fee Rule)
 Notice of Rulemaking – Adoption of Pending Rule248

IDAPA 24 – DIVISION OF OCCUPATIONAL AND PROFESSIONAL LICENSES

24.03.01 – *Rules of the State Board of Chiropractic Physicians*
Docket No. 24-0301-2401 (ZBR Chapter Rewrite)
 Notice of Rulemaking – Adoption of Pending Rule249

24.04.01 – *Rules of the Board of Registration for Professional Geologists*
Docket No. 24-0401-2401 (ZBR Chapter Rewrite, Fee Rule)
 Notice of Rulemaking – Proposed Rule252

24.09.01 – *Rules of the Board of Examiners of Nursing Home Administrators*
Docket No. 24-0901-2401 (ZBR Chapter Rewrite)
 Notice of Rulemaking – Adoption of Pending Rule259

24.19.01 – *Rules of the Board of Examiners of Residential Care Facility Administrators*
Docket No. 24-1901-2401 (ZBR Chapter Rewrite, Fee Rule)
 Notice of Rulemaking – Adoption of Pending Rule260

24.21.01 – *Rules of the Idaho State Contractors Board*
Docket No. 24-2101-2401 (ZBR Chapter Rewrite)
 Notice of Rulemaking – Proposed Rule261

24.24.01 – Rules of the Genetic Counselors Licensing Board Docket No. 24-2401-2401 (ZBR Chapter Rewrite) Notice of Rulemaking – Adoption of Pending Rule	264
24.33.01 – Rules of the Board of Medicine for the Practice of Medicine and Osteopathic Medicine in Idaho Docket No. 24-3301-2401 (ZBR Chapter Rewrite, Fee Rule) Notice of Rulemaking – Adoption of Pending Rule	265
24.33.02 – Rules for the Licensure of Physician Assistants Docket No. 24-3302-2401 (ZBR Chapter Rewrite) Notice of Rulemaking – Adoption of Pending Rule	266
24.33.03 – General Provisions of the Board of Medicine Docket No. 24-3303-2401 (ZBR Chapter Repeal) Notice of Rulemaking – Adoption of Pending Rule	267
24.33.04 – Rules for the Licensure of Naturopathic Medical Doctors Docket No. 24-3304-2401 (ZBR Chapter Rewrite) Notice of Rulemaking – Adoption of Pending Rule	268
24.33.05 – Rules for the Licensure of Athletic Trainers to Practice in Idaho Docket No. 24-3305-2401 (ZBR Chapter Rewrite) Notice of Rulemaking – Adoption of Pending Rule	269
24.33.06 – Rules for Licensure of Respiratory Therapists and Permitting of Polysomnographers in Idaho Docket No. 24-3306-2401 (ZBR Chapter Rewrite) Notice of Rulemaking – Adoption of Pending Rule	270
24.33.07 – Rules for the Licensure of Dietitians Docket No. 24-3307-2401 (ZBR Chapter Rewrite) Notice of Rulemaking – Adoption of Pending Rule	271
24.39.10 – Rules of the Idaho Electrical Board Docket No. 24-3910-2402 Notice of Rulemaking – Proposed Rule	272
IDAPA 26 – DEPARTMENT OF PARKS AND RECREATION	
26.01.37 – Rules Governing Test Procedures and Instruments for Noise Abatement of Off Highway Vehicles Docket No. 26-0137-2401 (ZBR Chapter Repeal) Notice of Rulemaking – Proposed Rule	281
IDAPA 31 – IDAHO PUBLIC UTILITIES COMMISSION	
31.21.01 – Customer Relations Rules for Gas, Electric, and Water Public Utilities (The Utility Customer Relations Rules) Docket No. 31-2101-2401 Notice of Rulemaking – Adoption of Pending Rule	282
31.41.01 – Customer Relations Rules for Telephone Corporations Providing Services in Idaho Subject to Customer Service Regulation by the Idaho Public Utilities Commission (The Telephone Customer Relations Rules) Docket No. 31-4101-2401 (ZBR Chapter Rewrite) Notice of Rulemaking – Proposed Rule	283

IDAPA 37 – IDAHO DEPARTMENT OF WATER RESOURCES*37.03.01 – Adjudication Rules****Docket No. 37-0301-2401 (ZBR Chapter Rewrite)***

Notice of Rulemaking – Proposed Rule305

*37.03.02 – Beneficial Use Examination Rules****Docket No. 37-0302-2401 (ZBR Chapter Rewrite)***

Notice of Rulemaking – Proposed Rule317

*37.03.03 – Rules and Minimum Standards for the Construction and Use of Injection Wells****Docket No. 37-0303-2301 (ZBR Chapter Rewrite)***

Notice of Rulemaking – Proposed Rule330

*37.03.09 – Well Construction Standards Rules****Docket No. 37-0309-2401 (ZBR Chapter Rewrite)***

Notice of Rulemaking – Proposed Rule366

*37.03.11 – Rules for Conjunctive Management of Surface and Ground Water Resources****Docket No. 37-0311-2401***

Notice of Rulemaking – Proposed Rule407

IDAPA 38 – DEPARTMENT OF ADMINISTRATION*38.05.01 – Rules of the Division of Purchasing****Docket No. 38-0501-2401***

Notice of Intent to Promulgate Rules – Negotiated Rulemaking409

IDAPA 39 – IDAHO TRANSPORTATION DEPARTMENT*39.02.03 – Rules Governing Vehicle Dealer’s Principal Place of Business and Claims to the Idaho
Consumer Asset Recovery Fund****Docket No. 39-0203-2401 (ZBR Chapter Rewrite)***

Notice of Rulemaking – Proposed Rule411

*39.02.75 – Rules Governing Names on Drivers’ Licenses and Identification Cards****Docket No. 39-0275-2401***

Notice of Rulemaking – Proposed Rule416

*39.03.41 – Rules Governing Traffic Control Devices****Docket No. 39-0341-2401***

Notice of Rulemaking – Proposed Rule420

*39.03.60 – Rules Governing Outdoor Advertising, Accident Memorials, and Other Official Signs****Docket No. 39-0360-2401 (ZBR Chapter Rewrite)***

Notice of Rulemaking – Proposed Rule443

*39.03.65 – Rules Governing Traffic Minute Entries****Docket No. 39-0365-2401 (ZBR Chapter Rewrite)***

Notice of Rulemaking – Proposed Rule458

IDAPA 43 – IDAHO OILSEED COMMISSION*43.01.01 – Rules Governing the Idaho Oilseed Commission****Docket No. 43-0101-2401 (ZBR Chapter Rewrite)***

Notice of Rulemaking – Proposed Rule461

IDAPA 47 – DIVISION OF VOCATIONAL REHABILITATION

47.01.01 – Rules Governing Vocational Rehabilitation Services

Docket No. 47-0101-2401

Notice of Rulemaking – Proposed Rule464

IDAPA 50 – COMMISSION OF PARDONS AND PAROLE

50.01.01 – Rules of the Commission of Pardons and Parole

Docket No. 50-0101-2401

Notice of Rulemaking – Temporary and Proposed Rule.....467

SECTIONS AFFECTED INDEX 470

LEGAL NOTICE - SUMMARY OF PROPOSED RULEMAKINGS 488

CUMULATIVE RULEMAKING INDEX OF IDAHO ADMINISTRATIVE RULES 492

SUBJECT INDEX 507

PREFACE

The Idaho Administrative Bulletin is an electronic-only, online monthly publication of the Office of the Administrative Rules Coordinator, Division of Financial Management, that is published pursuant to Section 67-5203, Idaho Code. The Bulletin is a compilation of all official rulemaking notices, official rule text, executive orders of the Governor, and all legislative documents affecting rules that are statutorily required to be published in the Bulletin. It may also include other rules-related documents an agency may want to make public through the Bulletin.

State agencies are required to provide public notice of all rulemaking actions and must invite public input. This is done through negotiated rulemaking procedures or after proposed rulemaking has been initiated. The public receives notice that an agency has initiated proposed rulemaking procedures through the Idaho Administrative Bulletin and a legal notice (Public Notice of Intent) that publishes in authorized newspapers throughout the state. The legal notice provides reasonable opportunity for the public to participate when a proposed rule publishes in the Bulletin. Interested parties may submit written comments to the agency or request public hearings of the agency, if none have been scheduled. Such submissions or requests must be presented to the agency within the time and manner specified in the individual “Notice of Rulemaking - Proposed Rule” for each proposed rule that is published in the Bulletin.

Once the comment period closes, the agency considers fully all comments and information submitted regarding the proposed rule. Changes may be made to the proposed rule at this stage of the rulemaking, but changes must be based on comments received and must be a “logical outgrowth” of the proposed rule. The agency may now adopt and publish the pending rule. A pending rule is “pending” legislative review for final approval. The pending rule is the agency’s final version of the rulemaking that will be forwarded to the legislature for review and final approval. Comment periods and public hearings are not provided for when the agency adopts a temporary or pending rule.

CITATION TO THE IDAHO ADMINISTRATIVE BULLETIN

The Bulletin is identified by the calendar year and issue number. For example, Bulletin **19-1** refers to the first Bulletin issued in calendar year **2019**; Bulletin **20-1** refers to the first Bulletin issued in calendar year **2020**. Volume numbers, which proceed from 1 to 12 in a given year, correspond to the months of publication, i.e.; Volume No. **19-1** refers to January 2019; Volume No. **20-2** refers to February 2020; and so forth. Example: The Bulletin published in January 2019 is cited as Volume **19-1**. The December 2019 Bulletin is cited as Volume **19-12**.

RELATIONSHIP TO THE IDAHO ADMINISTRATIVE CODE

The **Idaho Administrative Code** is an electronic-only, online compilation of all final and enforceable administrative rules of the state of Idaho that are of full force and effect. Any temporary rule that is adopted by an agency and is of force and effect is codified into the Administrative Code upon Bulletin publication. All pending rules that have been approved by the legislature during the legislative session as final rules and any temporary rules that are extended supplement the Administrative Code. These rules are codified into the Administrative Code upon becoming effective. Because proposed and pending rules are not enforceable, they are published in the Administrative Bulletin only and cannot be codified into the Administrative Code until approved as final.

To determine if a particular rule remains in effect or whether any amendments have been made to the rule, refer to the **Cumulative Rulemaking Index**. Link to it on the Administrative Rules homepage at adminrules.idaho.gov.

THE DIFFERENT RULES PUBLISHED IN THE ADMINISTRATIVE BULLETIN

Idaho’s administrative rulemaking process, governed by the Administrative Procedure Act, Title 67, Chapter 52, Idaho Code, comprises distinct rulemaking actions: negotiated, proposed, temporary, pending and final rulemaking. Not all rulemakings incorporate or require all of these actions. At a minimum, a rulemaking includes proposed, pending and final rulemaking. Many rules are adopted as temporary rules when they meet the required statutory criteria and agencies must, when feasible, engage in negotiated rulemaking at the beginning of the process to facilitate consensus building. In the majority of cases, the process begins with proposed rulemaking and ends with the final rulemaking. The following is a brief explanation of each type of rule.

1. NEGOTIATED RULEMAKING

Negotiated rulemaking is a process in which all interested persons and the agency seek consensus on the content of a rule through dialogue. Agencies are required to conduct negotiated rulemaking whenever it is feasible to do so. The agency files a “Notice of Intent to Promulgate – Negotiated Rulemaking” for publication in the Administrative Bulletin inviting interested persons to contact the agency if interested in discussing the agency’s intentions regarding the rule changes. This process is intended to result in the formulation of a proposed rule and the initiation of regular rulemaking procedures. One result, however, may also be that regular (proposed) rulemaking is not initiated and no further action is taken by the agency.

2. PROPOSED RULEMAKING

A proposed rulemaking is an action by an agency wherein the agency is proposing to amend or repeal an existing rule or to adopt a new rule. Prior to the adoption, amendment, or repeal of a rule, the agency must publish a “Notice of Rulemaking – Proposed Rule” in the Bulletin. This notice must include very specific information regarding the rulemaking including all relevant state or federal statutory authority occasioning the rulemaking, a non-technical description of the changes being made, any associated costs, guidance on how to participate through submission of written comments and requests for public hearings, and the text of the proposed rule in legislative format.

3. TEMPORARY RULEMAKING

Temporary rules may be adopted only when the governor finds that it is necessary for:

- a) protection of the public health, safety, or welfare; or
- b) compliance with deadlines in amendments to governing law or federal programs; or
- c) conferring a benefit.

If a rulemaking meets one or more of these criteria, and with the Governor’s approval, the agency may adopt and make a temporary rule effective prior to receiving legislative authorization and without allowing for any public input. The law allows an agency to make a temporary rule immediately effective upon adoption. A temporary rule expires at the conclusion of the next succeeding regular legislative session unless the rule is extended by concurrent resolution, is replaced by a final rule, or expires under its own terms.

4. PENDING RULEMAKING

A pending rule is a rule that has been adopted by an agency under regular rulemaking procedures and remains subject to legislative review before it becomes a final, enforceable rule. When a pending rule is published in the Bulletin, the agency is required to include certain information in the “Notice of Rulemaking – Pending Rule.” This includes a statement giving the reasons for adopting the rule, a statement regarding when the rule becomes effective, a description of how it differs from the proposed rule, and identification of any fees being imposed or changed.

Agencies are required to republish the text of the pending rule when substantive changes have been made to the proposed rule. An agency may adopt a pending rule that varies in content from that which was originally proposed if the subject matter of the rule remains the same, the pending rule change is a logical outgrowth of the proposed rule, and the original notice was written so as to assure that members of the public were reasonably notified of the subject. It is not always necessary to republish all the text of the pending rule.

5. FINAL RULEMAKING

A final rule is a rule that has been adopted by an agency under the regular rulemaking procedures and is of full force and effect.

HOW TO USE THE IDAHO ADMINISTRATIVE BULLETIN

Rulemaking documents produced by state agencies and published in the **Idaho Administrative Bulletin** are organized by a numbering schematic. Each state agency has a two-digit identification code number known as the “**IDAPA**” number. (The “IDAPA” Codes are listed in the alphabetical/numerical index at the end of this Preface.) Within each agency there are divisions or sections to which a two-digit “TITLE” number is assigned. There are “CHAPTER” numbers assigned within the Title and the rule text is divided among major sections that are further subdivided into subsections. An example IDAPA number is as follows:

IDAPA 38.05.01.200.02.c.ii.

“**IDAPA**” refers to Administrative Rules in general that are subject to the Administrative Procedures Act and are required by this act to be published in the Idaho Administrative Code and the Idaho Administrative Bulletin.

“**38.**” refers to the Idaho Department of Administration

“**05.**” refers to Title **05**, which is the Department of Administration’s Division of Purchasing

“**01.**” refers to Chapter **01** of Title 05, “Rules of the Division of Purchasing”

“**200.**” refers to Major Section **200**, “Content of the Invitation to Bid”

“**02.**” refers to Subsection 200.02.

“**c.**” refers to Subsection 200.02.c.

“**ii.**” refers to Subsection 200.02.c.ii.

DOCKET NUMBERING SYSTEM

Internally, the Bulletin is organized sequentially using a rule docketing system. Each rulemaking that is filed with the Coordinator is assigned a “DOCKET NUMBER.” The docket number is a series of numbers separated by a hyphen “-”, (**38-0501-1401**). Rulemaking dockets are published sequentially by IDAPA number (the two-digit agency code) in the Bulletin. The following example is a breakdown of a typical rule docket number:

“DOCKET NO. 38-0501-1901”

“**38-**” denotes the agency’s **IDAPA** number; in this case the Department of Administration.

“**0501-**” refers to the **TITLE AND CHAPTER** numbers of the agency rule being promulgated; in this case the Division of Purchasing (**TITLE 05**), Rules of the Division of Purchasing (**Chapter 01**).

“**1901**” denotes the year and sequential order of the docket being published; in this case the numbers refer to the first rulemaking action published in **calendar year 2019**. A subsequent rulemaking on this same rule chapter in calendar year 2019 would be designated as “**1902**”. The docket number in this scenario would be 38-0501-**1902**.

Within each Docket, only the affected sections of chapters are printed. (See **Sections Affected Index** in each Bulletin for a listing of these.) The individual sections affected are printed in the Bulletin sequentially (e.g. Section “200” appears before Section “345” and so on). Whenever the sequence of the numbering is broken the following statement will appear:

(BREAK IN CONTINUITY OF SECTIONS)

BULLETIN PUBLICATION SCHEDULE FOR YEAR 2024

Vol. No.	Monthly Issue of Bulletin	ARRF Due to DFM	Closing Date for Agency Filing	Bulletin Publication Date	21-day Comment Period End Date
24-2	February 2024	December 22, 2023	January 5, 2024	February 7, 2024	February 28, 2024
24-3	March 2024	January 26, 2024	February 9, 2024	March 6, 2024	March 27, 2024
24-4	April 2024	February 23, 2024	March 8, 2024	April 3, 2024	April 24, 2024
24-5	May 2024	March 22, 2024	April 5, 2024	May 1, 2024	May 22, 2024
24-6	June 2024	April 19, 2024	May 3, 2024	June 5, 2024	June 26, 2024
24-7	July 2024	May 24, 2024	June 7, 2024	July 3, 2024	July 24, 2024
24-8	August 2024	June 21, 2024	July 5, 2024	August 7, 2024	August 28, 2024
24-9	September 2024	July 19, 2024	August 2, 2024	September 4, 2024	September 25, 2024
24-10	October 2024	August 16, 2024	*August 30, 2024	October 2, 2024	October 23, 2024
24-11	November 2024	September 20, 2024	October 4, 2024	November 6, 2024	November 27, 2024
24-12	December 2024	October 25, 2024	November 8, 2024	December 4, 2024	December 25, 2024
25-1	January 2025	November 15, 2024	**November 29, 2024	January 1, 2025	January 22, 2025

BULLETIN PUBLICATION SCHEDULE FOR YEAR 2025

Vol. No.	Monthly Issue of Bulletin	ARRF Due to DFM	Closing Date for Agency Filing	Bulletin Publication Date	21-day Comment Period End Date
25-2	February 2025	December 20, 2024	January 3, 2025	February 5, 2025	February 26, 2025
25-3	March 2025	January 24, 2025	February 7, 2025	March 5, 2025	March 26, 2025
25-4	April 2025	February 21, 2025	March 7, 2025	April 2, 2025	April 23, 2025
25-5	May 2025	March 21, 2025	April 4, 2025	May 7, 2025	May 28, 2025
25-6	June 2025	April 18, 2025	May 2, 2025	June 4, 2025	June 25, 2025
25-7	July 2025	May 23, 2025	June 6, 2025	July 2, 2025	July 23, 2025
25-8	August 2025	June 20, 2025	July 3, 2025	August 6, 2025	August 27, 2025
25-9	September 2025	July 18, 2025	August 1, 2025	September 3, 2025	September 24, 2025
25-10	October 2025	August 15, 2025	*August 29, 2025	October 1, 2025	October 22, 2025
25-11	November 2025	September 19, 2025	October 3, 2025	November 5, 2025	November 26, 2025
25-12	December 2025	October 24, 2025	November 7, 2025	December 3, 2025	December 24, 2025
26-1	January 2026	November 21, 2025	**December 5, 2025	January 7, 2026	January 28, 2026

***Last day to submit a proposed rule for the rulemaking to remain on course for review by the upcoming legislature.**

****Last day to submit a pending rule to be reviewed by the upcoming legislature.**

ALPHABETICAL INDEX OF STATE AGENCIES AND CORRESPONDING IDAPA NUMBERS	
IDAPA 38	Administration , Department of
IDAPA 62	Administrative Hearings , Office of
IDAPA 02	Agriculture , Idaho State Department of
IDAPA 40	Arts , Idaho Commission on the
IDAPA 04	Attorney General , Office of the
IDAPA 53	Barley Commission , Idaho
IDAPA 51	Beef Council , Idaho
IDAPA 55	Career Technical Education , Division of
IDAPA 28	Commerce , Idaho Department of
IDAPA 06	Correction , Idaho Department of
IDAPA 08	Education , State Board of and State Department of
IDAPA 32	Endowment Fund Investment Board
IDAPA 58	Environmental Quality , Department of
IDAPA 12	Finance , Idaho Department of
IDAPA 13	Fish and Game , Idaho Department of
IDAPA 15	Governor , Office of the Idaho Commission on Aging (15.01) Idaho Commission for the Blind and Visually Impaired (15.02) Idaho Forest Products Commission (15.03) Division of Human Resources and Personnel Commission (15.04) Idaho Military Division (Division of Homeland Security) (15.06) Idaho State Liquor Division (15.10)
IDAPA 48	Grape Growers and Wine Producers Commission , Idaho
IDAPA 16	Health and Welfare , Department of
IDAPA 41	Health Districts , Public
IDAPA 45	Human Rights Commission
IDAPA 17	Industrial Commission , Idaho
IDAPA 18	Insurance , Idaho Department of
IDAPA 05	Juvenile Corrections , Department of
IDAPA 09	Labor , Idaho Department of

ALPHABETICAL INDEX OF STATE AGENCIES AND CORRESPONDING IDAPA NUMBERS	
IDAPA 20	Lands, Idaho Department of
IDAPA 52	Lottery Commission, Idaho State
IDAPA 24	Occupational and Professional Licenses, Division of (24.20) Accountancy, Board of (24.30) Acupuncture, Board of (24.17) Architectural Examiners, Board of (24.01) Athletic Commission, State (24.02) Barber and Cosmetology Services Licensing Board (24.28) Building Safety, Division of (24.39) Chiropractic Physicians, Board of (24.03) Contractors Board, Idaho State (24.21) Counselors and Marriage and Family Therapists, Licensing Board of Professional (24.15) Dentistry, State Board of (24.31) Denturity, Board of (24.16) Drinking Water and Wastewater Professionals, Board of (24.05) Driving Businesses Licensure Board, Idaho (24.25) Engineers and Land Surveyors, Board of Licensure of Professional (24.32) Genetic Counselors Licensing Board (24.24) Geologists, Board of Registration for Professional (24.04) Landscape Architects, Board of (24.07) Liquefied Petroleum Gas Safety Board (24.22) Massage Therapy, Board of (24.27) Medicine, Board of (24.33) Midwifery, Board of (24.26) Morticians, Board of (24.08) Nursing, Board of (24.34) Nursing Home Administrators, Board of Examiners of (24.09) Occupational Therapy Licensure Board (24.06) Optometry, Board of (24.10) Outfitters and Guides Licensing Board (24.35) Pharmacy, Board of (24.36) Physical Therapy Licensure Board (24.13) Podiatry, Board of (24.11) Psychologist Examiners, Board of (24.12) Real Estate Appraiser Board (24.18) Real Estate Commission (24.37) Residential Care Facility Administrators, Board of Examiners of (24.19) Shorthand Reporters Board, Idaho Certified (24.29) Social Work Examiners, Board of (24.14) Speech, Hearing and Communication Services Licensure Board (24.23) Veterinary Medicine, State Board of (24.38)
IDAPA 43	Oilseed Commission, Idaho
IDAPA 50	Pardons and Parole, Commission of
IDAPA 26	Parks and Recreation, Idaho Department of

ALPHABETICAL INDEX OF STATE AGENCIES AND CORRESPONDING IDAPA NUMBERS	
IDAPA 11	Police, Idaho State Alcohol Beverage Control (11.05) Brand Board (11.02) Commercial Vehicle Safety (11.13) Forensic Laboratory (11.03) Motor Vehicles (11.07) Peace Officer Standards and Training Council (11.11) Public Safety and Security Information (11.10) Racing Commission (11.04)
IDAPA 29	Potato Commission, Idaho
IDAPA 61	Public Defense Commission, State
IDAPA 59	Public Employee Retirement System of Idaho (PERSI)
IDAPA 31	Public Utilities Commission
IDAPA 34	Secretary of State, Office of the
IDAPA 57	Sexual Offender Management Board
IDAPA 60	Soil and Water Conservation Commission, Idaho State
IDAPA 36	Tax Appeals, Board of
IDAPA 35	Tax Commission, State
IDAPA 39	Transportation Department, Idaho
IDAPA 21	Veterans Services, Division of
IDAPA 47	Vocational Rehabilitation, Division of
IDAPA 37	Water Resources, Department of
IDAPA 42	Wheat Commission, Idaho

IDAPA 02 – IDAHO STATE DEPARTMENT OF AGRICULTURE

02.02.12 – BONDED WAREHOUSE RULES

DOCKET NO. 02-0212-2401 (ZBR CHAPTER REWRITE)

NOTICE OF RULEMAKING – PROPOSED RULE

AUTHORITY: In compliance with Section 67-5221(1), Idaho Code, notice is hereby given that this agency has initiated proposed rulemaking procedures. The action is authorized pursuant to Sections 69-231, Idaho Code.

PUBLIC HEARING SCHEDULE: Public hearing(s) concerning this rulemaking will be scheduled if requested in writing by twenty-five (25) persons, a political subdivision, or an agency, not later than October 16, 2024.

The hearing site(s) will be accessible to persons with disabilities. Requests for accommodation must be made not later than five (5) days prior to the hearing, to the agency address below.

DESCRIPTIVE SUMMARY: The following is a nontechnical explanation of the substance and purpose of the proposed rulemaking:

This rule is being presented for authorization as part of the ISDA’s plan to review each rule every 5 years. Redundant language that is verbatim in statute has been removed, consistent with the Governor’s [Zero-Based Regulation Executive Order](#).

The rule was reviewed over the course of two negotiated rulemaking meetings, and that review benefited from the participation of program stakeholders. No negative comments were submitted as part of this rulemaking process.

This rule clarifies the procedure for licensing and monitoring warehouses in the state of Idaho, maintaining electronic records, and remedies of the Department for non-compliance.

FEE SUMMARY: The following is a specific description of the fee or charge imposed or increased: There is no change in fee or charge.

FISCAL IMPACT: The following is a specific description, if applicable, of any negative fiscal impact on the state General Fund greater than ten thousand dollars (\$10,000) during the fiscal year resulting from this rulemaking:

There is no fiscal impact on the state General Fund greater than ten thousand dollars (\$10,000).

NEGOTIATED RULEMAKING: Pursuant to Section 67-5220(1), Idaho Code, negotiated rulemaking was conducted. The Notice of Intent to Promulgate Rules - Negotiated Rulemaking was published in the July 3, 2024 Idaho Administrative Bulletin, [Volume 24-7, Pages 18 and 19](#).

INCORPORATION BY REFERENCE: Pursuant to Section 67-5229(2)(a), Idaho Code, the following is a brief synopsis of why the materials cited are being incorporated by reference into this rule:

There are no documents incorporated by reference.

IDAHO CODE SECTION 22-101A STATEMENT: Pursuant to 22-101A(1), for any rule promulgated or adopted by the director which is broader in scope or more stringent than federal law or regulations, or which regulates an activity not regulated by the federal government, the director shall identify the portions of the adopted rule that are broader in scope or more stringent than federal law or rules, or which regulate an activity not regulated by the federal government. The following sections of the rule are broader in scope, more stringent than federal law or regulations, or regulate an activity not regulated by the federal government:

The federal government does not regulate state licensed warehouses. This activity is defined in Idaho Code.

The detailed 22-101A analysis can be found on the agency’s website at www.agri.idaho.gov.

ASSISTANCE ON TECHNICAL QUESTIONS, SUBMISSION OF WRITTEN COMMENTS: For assistance on technical questions concerning the proposed rule, contact Lloyd Knight at lloyd.knight@isda.idaho.gov.

Anyone may submit written comments regarding this proposed rulemaking. All written comments must be directed to the undersigned and must be delivered on or before October 23, 2024.

DATED this 2nd day of October, 2024.

Lloyd Knight
Deputy Director
Idaho Department of Agriculture
2270 Old Penitentiary Road
P.O. Box 7249
Boise, Idaho 83707
Phone: (208) 332-8615
Email: lloyd.knight@isda.idaho.gov

THE FOLLOWING IS THE PROPOSED TEXT OF DOCKET NO. 02-0212-2401
(ZBR Chapter Rewrite)

02.02.12 – BONDED WAREHOUSE RULES

000. LEGAL AUTHORITY.

~~This chapter is adopted under the legal authority of~~ Section 69-231, Idaho Code. (3-15-22)()

001. ~~TITLE AND SCOPE.~~

01. ~~Title.~~ The title of this chapter is IDAPA 02.02.12, “Bonded Warehouse Rules.” (3-15-22)

02. ~~Scope.~~ These rules clarify the procedure for licensing, collection and remittance of assessment, determining claim value, maintaining electronic records use of electronic scales and remedies of the Department for non-compliance. (3-15-22)()

002. -- 009. (RESERVED)

010. DEFINITIONS.

The definitions set forth in Section 69-202, Idaho Code, and the following apply: (3-15-22)

01. Cash Sale. Payment to the producer by the warehouse or dealer contemporaneously with the transfer of commodity to the warehouse or dealer. (3-15-22)

02. Commodity Indemnity Fund (CIF). Commodity Indemnity Fund is a trust fund. (3-15-22)

03. Credit-Sale Contract. An agreement in writing containing the provisions of Section 69-249, Idaho Code, and where the producer transfers a specific quantity of commodity to a warehouse or dealer with a price or payment to the producer by the warehouse or dealer to be made at a later date or on the occurrence of a specific event expressed in the agreement. (3-15-22)

04. Dealer. Is limited to dealers licensed by the state of Idaho. (3-15-22)

05. Deposit for Service. Deposit of a commodity by a person for cleaning, processing, reconditioning or the rendering of other similar services by a warehouse, but does not include either a cash sale, credit-sale, or open

storage. (3-15-22)

06. NPE. (No price established contract) A contract containing no readily calculable sale value of the commodity for the producer. (3-15-22)

07. Open Storage. The deposit of commodity by the producer for a period of time with the subsequent disposition of the same commodity or a fungible commodity as agreed to by the parties. (3-15-22)

08. Warehouse. Is limited to warehouses licensed by the state of Idaho. (3-15-22)

011. (RESERVED)

012. LICENSING.

01. Posting of License. Immediately upon receipt of the license or any renewal, extension or modification thereof under Title 69, Chapter 2, Idaho Code, the licensed warehouseman shall post the license in a conspicuous place in each place of business or in any other place as the Director may determine. The Department will issue a duplicate license for each additional facility as needed. (3-15-22)

02. Return of Suspended or Terminated License. If a license issued to a warehouseman has lapsed or is suspended, revoked or canceled by the Director, the license shall be returned to the Department. (3-15-22)

03. Suspension Due to Neglect. If, through inspection or other information, it is revealed or indicated that the commodities in storage are deteriorating due to the warehouseman's or operator's neglect, the license may be suspended until the matter has been corrected to the satisfaction of the Director. (3-15-22)

04. Loss of License. Upon satisfactory proof of the loss or destruction of a license issued to a warehouseman, a duplicate may be issued under the same number or a new number at the discretion of the Director. (3-15-22)

05. Sign to Be Posted. Each licensed warehouseman shall maintain suitable signs on the licensed property in such manner as will give ample public notice of his tenancy. These signs shall be painted on the warehouse or elevator in letters not less than six (6) inches in height and contain the following words: "State No. ____." The number of each warehouse will be assigned by the Director. (3-15-22)

06. Bins Labeled. All storage areas licensed for the storage of agricultural commodities shall be numbered and have a diagram of the storage areas kept in the office showing the exact dimensions and the maximum capacity of the storage area. (3-15-22)

07. Insurance Calculations. The director may approve a request to reduce the insurance calculation for a facility provided the request is in writing and evidence is supplied that all agricultural commodities that are stored at any given point in time are insured pursuant to Title 69, Chapter 2, Idaho Code. (3-15-22)

013. -- 049. (RESERVED)

050. RECEIPTING.

01. Every Warehouseman. Every warehouseman shall issue a negotiable warehouse receipt when requested to do so by the depositor. All storage and handling charges are due and payable on or before July 1 following the date of the issuance of the receipt, or as agreed upon by the parties. (3-15-22)

02. Form of Nonnegotiable Warehouse Receipts. Nonnegotiable warehouse receipts that contain the essential terms for warehouse receipts as set forth in Section 28-7-202, Idaho Code, and Section 69-223, Idaho Code, are deemed sufficient for all purposes. Copies of all nonnegotiable warehouse receipts shall be kept as permanent records by the warehouseman issuing them. (3-15-22)

~~**03. Lost Negotiable Warehouse Receipt.** To cancel an outstanding warehouse receipt or issue a new~~

~~warehouse receipt supplementing one that has been lost or destroyed, the licensed warehouseman shall require the depositor or other applicant to submit to the warehouseman:~~ (3-15-22)

~~a. An affidavit showing that he is lawfully entitled to the possession of the original receipt, that he has not negotiated or assigned it and how the original receipt was lost or destroyed; and~~ (3-15-22)

~~b. A bond in the amount double the market value of the agricultural commodity represented by the lost or destroyed receipt. The market value shall be determined at the time this bond is submitted for the lost receipt. A duplicate warehouse receipt shall clearly state that it is a duplicate receipt, the number of the receipt the duplicate is replacing, and the license number under which the original receipt was issued.~~ (3-15-22)

043. Electronic Warehouse Receipts. ~~An electronic version of a warehouse receipt generated by a provider licensed and approved by the United States Department of Agriculture (USDA) that contains the same information as the paper version of a warehouse receipt may be issued instead of a paper document. The electronic version of a warehouse receipt carries the same rights and obligations as the paper version. At no time may a paper receipt and an electronic receipt represent the same lot of commodity. Electronic warehouse receipts shall be numbered and issued consecutively starting with the number specified to the provider by the department.~~ (3-15-22)()

054. Agreements. Prior to entering into an agreement with an electronic warehouse receipt provider to issue such receipts, a warehouse licensee must provide a copy of the proposed agreement to the department for review and approval. A warehouse operator shall not issue electronic negotiable warehouse receipts until and unless the department approves its agreement with an electronic warehouse receipt provider and notifies the licensee of such approval. A provider shall be independent of any outside influence or bias in action or appearance. In order to be approved by the department, an electronic warehouse receipt provider agreement shall: (3-15-22)

a. Only be with a provider that is first approved as an electronic warehouse receipt provider by the USDA pursuant to the provisions of 7 CFR Part 735. Upon department request, a provider shall provide a copy of the provider's executed USDA Form WA-460 and any addenda, and any other documentation requested by the department to confirm that the provider is a USDA-approved provider in good standing. (3-15-22)

b. Provide for the department to become a joint holder on all open electronic negotiable warehouse receipts if the issuing warehouse operator's license is relinquished or revoked. (3-15-22)

c. ~~Require the p~~Provider to provide security as required by its provider agreement with the USDA regarding on-site security, data authorization, security plans, and facility vulnerability. (3-15-22)()

d. ~~Prohibit the provider~~Refrain from deleting or altering any electronic negotiable warehouse receipts in the centralized filing system unless such actions are authorized by the department. (3-15-22)()

e. Allow the department unrestricted access to the central filing system for electronic warehouse receipts issued on behalf of warehouse operators licensed by the department. The electronic warehouse receipt data shall be maintained for six (6) years after cancellation of the receipts. Access shall be free of charge and made available in a manner that allows interaction with department warehouse examinations. (3-15-22)

f. ~~Require the provider, w~~When a warehouse operator changes provider, to supply the new provider and the warehouse operator with a complete list of all the current holders of open electronic negotiable commodity warehouse receipts prior to the intended transfer date. (3-15-22)()

065. Change in Provider. A warehouse operator shall issue electronic warehouse receipts through only one (1) approved provider at a time. (3-15-22)

a. A warehouse operator may change providers only once a year unless otherwise approved by the department. (3-15-22)

b. A warehouse operator shall notify the department of the exact date of the proposed transfer thirty (30) calendar days prior to the intended date of any transfer to a new provider. The operator must also, thirty (30)

days prior to the intended transfer date, send notices of the change to the holders of all open electronic negotiable warehouse receipts specifying the date and time period during which access to receipts will not be available. (3-15-22)

051. -- 079. (RESERVED)

080. FORWARDING AGRICULTURAL COMMODITIES.

Warehouses licensed under Title 69, Chapter 2, Idaho Code, receiving agricultural commodities for shipment to terminals or to other warehouses for storage or processing within the state or outside the state shall have in their possession a statement authorizing the shipment of agricultural commodities to another location for storage or processing that is signed by the owner or producer of the agricultural commodity. The receiving warehouse shall be a state or federally licensed and bonded warehouse or have a Commodity Credit Corporation storage agreement. When requested to do so by an Idaho Warehouse Examiner, the shipping warehouse shall promptly procure from the terminal or storage warehouse a statement or negotiable warehouse receipt on a form approved by the director describing the quantity, class and grade of all agricultural commodities so shipped and in storage. The shipping warehouse shall have such forms promptly forwarded and returned to the Idaho Department of Agriculture, Bureau of Warehouse Control, within fifteen (15) days of issuance. (3-15-22)

081. -- 099. (RESERVED)

100. OFFICE RECORDS.

A warehouseman shall maintain complete and sufficient records to show all deposits, purchases, sales contracts, storage obligations and loadouts of the warehouse in this state that are subject to Department inspection during normal business hours. Office records as set forth in Title 69, Chapter 2, Idaho Code, include, but not limited to, the following: (3-15-22)

01. Daily Position Record. This shows the total quantity of each kind and class of agricultural commodity received and loaded out, the amount remaining in storage at the close of each business day, and the warehouseman's total storage obligation for each kind and class of agricultural commodity at the close of each business day. (3-15-22)

02. Storage Ledger. This shows the name and address of the depositor, the date purchased, the terms of the sale, and the quality and quantity of the agricultural commodity purchased by the warehouseman. When applicable, the storage ledger shall also show the tare, grade, size, net weight, and unsold amount of agricultural commodities. (3-15-22)

03. Scale Weight Tickets. Scale weight tickets, except tickets for electronic scales that are recorded and maintained electronically, shall be pre-numbered with one (1) copy of each ticket maintained in numerical order. All scale weight tickets shall show the time when the commodities were delivered, the quantities delivered, who delivered the commodities, the ownership of the commodities, and the condition of the commodities upon delivery. (3-15-22)

04. Receipts and Tickets. Receipts and tickets in the warehouseman's possession that have not been issued. (3-15-22)

05. Receipts and Tickets Issued by the Warehouseman. Receipts and tickets issued by the warehouseman. (3-15-22)

06. Receipts and Tickets Returned and Cancelled. Receipts and tickets returned to and cancelled by the warehouseman. (3-15-22)

07. Insurance Documentation. (3-15-22)

08. Electronic Records. If any electronic records are maintained outside of the state of Idaho, the Department is entitled to examine them at any reasonable time and place as determined by the Department. (3-15-22)

101. -- 129. (RESERVED)

130. LICENSE APPLICATION AND CONDITIONS OF ISSUANCE.

01. License Application. Application for a license to operate a warehouse under the provisions of Title 69, Chapter 2, Idaho Code, shall be on a form prescribed by the Department and include: (3-15-22)

a. The full name of the person applying for the license and whether the applicant is an individual, partnership, association, corporation or other entity. (3-15-22)

b. The full name of each member of the firm or partnership, or the names of the officers and directors of the company or limited liability company, association, or corporation. (3-15-22)

c. The address of the principal place of business. (3-15-22)

d. Information relating to any judgments against the applicants. (3-15-22)

e. The location of each warehouse the applicant intends to operate and the commodities expected to be stored. (3-15-22)

f. A current financial statement as specified by Section 69-206, Idaho Code. (3-15-22)

g. A sketch or drawing as specified in Section 69-206, Idaho Code. (3-15-22)

h. A bond as required by Section 69-208, Idaho Code. (3-15-22)

i. Proof of insurance as required by Section 69-206, Idaho Code. (3-15-22)

j. The license fee as prescribed by Section 69-211, Idaho Code. (3-15-22)

k. Any other reasonable information the Department finds necessary to carry out the purpose and provisions of Title 69, Chapter 2, Idaho Code. (3-15-22)

02. Modification. If a licensee wishes to add additional capacity to an existing license, the Director may modify the license if all requirements of Section 69-206, Idaho Code, are met. (3-15-22)

131. AMOUNT OF BOND, IRREVOCABLE LETTER OF CREDIT, CERTIFICATE OF DEPOSIT, OR SINGLE BOND.

~~**01. Bonding Requirement.** The amount of bond to be furnished shall be fixed at a rate pursuant to Section 69-208A, Idaho Code. (3-15-22)~~

02. Single Bond, Irrevocable Letter of Credit or Certificate of Deposit. For the purposes of licensing as a warehouseman pursuant to Title 69, Chapter 2, Idaho Code and a seed buyer pursuant to Title 22, Chapter 51, Idaho Code a single bond, irrevocable letter of credit or certificate of deposit shall be fixed at whichever of the following amounts is greater: (3-15-22)

a. Combined total indebtedness paid and owed to producers for agricultural commodity and seed crop, without any deductions, for the previous license year; or (3-15-22)

b. The indebtedness owed and estimated to be owed to producers for agricultural commodity and seed crop, without any deductions, for the current license year. (3-15-22)

132. -- 149. (RESERVED)

150. WAREHOUSES TO BE KEPT CLEAN.

Each warehouseman is required to use such precautions and surveillance as is necessary to provide for the safe and adequate storage of all commodities stored in his warehouse and to prevent these commodities from being

contaminated in any way from chemicals, pesticides, fertilizers, adulterated seeds, animals, birds or any such thing as may contaminate or reduce the quality of stored goods. (3-15-22)

151. -- 179. (RESERVED)

180. WAREHOUSEMAN RESPONSIBILITIES.

01. Warehouse Receipts -- Quality. A warehouseman licensed under Title 69, Chapter 2, Idaho Code, shall maintain in the facility of issuance of any negotiable warehouse receipt, for as long as the receipt is outstanding and has not been canceled, like variety, quantity, and quality of the agricultural commodity stated on the receipt. No warehouseman shall remove, deliver, direct or permit any person to remove or deliver any agricultural commodity from any warehouse for which warehouse receipts have been issued and are outstanding, without receiving and canceling the warehouse receipt that was issued for the commodity, except if the Director determines an emergency storage situation exists. A warehouseman may then forward agricultural commodities to other licensed warehouses for storage without canceling the outstanding warehouse receipt, provided the following conditions are met: (3-15-22)

a. The warehouseman obtains written approval from the Department prior to forwarding agricultural commodities. (3-15-22)

b. The warehouseman provides written guidelines to the Department establishing how he will be back in position within the time limits set and granted by the Department. (3-15-22)

c. The warehouseman maintains and makes available to the Department records of positions concerning the forwarding of agricultural commodities. (3-15-22)

d. The receiving warehouse is a state or federally licensed and bonded warehouse or have a Commodity Credit Corporation storage agreement. (3-15-22)

e. The shipping warehouse has in its possession a statement signed by the bearer of the warehouse receipt authorizing the shipment of agricultural commodities represented by such receipt to another location for storage. (3-15-22)

f. When requested to do so by the Department, the shipping warehouseman shall promptly procure from the receiving warehouseman a statement describing the quantity, class and grade of all agricultural commodities so shipped and in storage on a form approved by the Director. The shipping warehouseman shall have such forms promptly forwarded to the receiving warehouseman for verification of quantity, class and grade of agricultural commodities forwarded and return the verification to the Department within fifteen (15) days of issuance. Failure to provide this statement to the Department in the above specified time, will result in a short position for the warehouseman with penalties as prescribed by law. (3-15-22)

02. Rights and Duties of Licensees -- Unlawful Practices. It is unlawful for a warehouseman to: (3-15-22)

a. Issue a warehouse receipt in excess of the amount of the agricultural commodity held in the licensee's warehouse to cover such receipt. (3-15-22)

b. Sell, encumber, ship, transfer, remove or permit to be sold encumbered, shipped, transferred or removed from a warehouse any agricultural commodity received by him for deposit, shipment or handling for which scale weight tickets have been issued without the written approval of the holder of the scale weight ticket and such transfer shall be shown on the individual depositor's account and the inventory records of the warehouseman. (3-15-22)

e. ~~Remove or permit any person to remove any agricultural commodity from a warehouse when the amount of any fairly representative grade or class of an agricultural commodity in the warehouses of such licensee is reduced below the amount for which a warehouse receipt or scale weight ticket for the particular agricultural commodity is outstanding, except as provided for in Section 69-223(2), Idaho Code, and Rule 180.01.~~ (3-15-22)

dc. Issue a warehouse receipt or scale weight ticket that exceeds the amount of agricultural commodities delivered for storage. (3-15-22)

ed. Issue a warehouse receipt showing a grade or description different from the grade or description of the agricultural commodities delivered and for which such warehouse receipt is issued. (3-15-22)

fe. Fail to deliver agricultural commodities as required by Section 28-7-402, Idaho Code. (3-15-22)

gf. Knowingly accept for storage any agricultural commodity destined for human consumption that has been contaminated, if such agricultural commodities are commingled with any uncontaminated agricultural commodity. (3-15-22)

hg. Terminate storage of an agricultural commodity in the warehouse without giving reasonable notice to the depositor as provided in Section 28-7-206, Idaho Code. (3-15-22)

ih. Alter, falsify, or withhold records from the warehouse examiner. (3-15-22)

181. -- 199. (RESERVED)

200. INSURANCE SETTLEMENT.

When the commodities within a licensed warehouse have been damaged or destroyed, the warehouseman shall make complete settlement to all depositors having agricultural commodities stored in the warehouse within ten (10) days after a settlement with the insurance company. Failure of the warehouseman to make such settlement is grounds for revocation of the license. However, such settlement need not be made within the ten (10) days period if the warehouseman and the depositor agree to other terms. In the case of commingled agricultural commodities where only a portion is damaged, settlement may be made on a pro rata basis to the owners of all agricultural commodities stored within the warehouse. (3-15-22)

201. -- 229. (RESERVED)

230. AGRICULTURAL COMMODITIES -- WAREHOUSE OBLIGATIONS.

Any agricultural commodity deposited for storage that is not sold by contract or otherwise, as shown by documentation, is open storage and shall be considered a warehouse obligation. (3-15-22)

231. -- 299. (RESERVED)

300. FINANCIAL STATEMENTS.

In order to obtain a bonded warehouse license, the applicant shall submit a current financial statement that has been prepared not more than ninety (90) days prior to the date of application and conform to the applicable requirements of Title 69, Chapter 2, Idaho Code, as to annual financial statements. (3-15-22)

01. Statement Compliance. Each licensed warehouseman shall submit to the Department an annual financial statement that has been audited or reviewed by an independent certified public accountant or independent licensed public accountant and be submitted to the Department no later than ninety (90) days after the end of the warehouseman's fiscal year. ~~The warehouse license may be suspended or revoked for failure to comply with licensing requirements stated in Bonded Warehouse Rule Section 300 and Section(s) 69-206(6) and (7), Idaho Code.~~ (3-15-22)()

a. The Department may grant an extension of no more than sixty (60) days, provided sufficient cause of an exceptional nature is provided, in writing, to the Department by a certified public accountant or a licensed public accountant and made prior to the date the financial statement is due. (3-15-22)

b. The director may make exceptions to the financial statement requirements provided sufficient cause is provided and to do so would be in the best interest of the State. (3-15-22)

02. Statement Content. The acceptable statement includes: (3-15-22)

- a. A balance sheet. (3-15-22)
- b. An income statement that includes annual gross sales of commodities purchased from producers covered under the act. (3-15-22)
- c. A statement of cash flows. (3-15-22)
- d. All accompanying notes to the financial statement. (3-15-22)

301. -- 329. (RESERVED)

330. AMENDING TARIFF.

Tariffs may be amended by the licensed warehouseman by filing a new tariff with the Department. The previous tariff continues to apply on all commodities received prior to the effective date of the amended tariff until the anniversary date of deposit. The amended tariff applies to any commodities received after the effective date of the amendment and on any commodities stored under the previous tariff commencing on the anniversary date of the storage period. (3-15-22)

331. -- 379. (RESERVED)

380. LICENSE -- DURATION.

Licenses issued under the provisions of Title 69, Chapter 2, Idaho Code, expire annually on April 30th. (3-15-22)

381. -- 399. (RESERVED)

400. INSURANCE DEDUCTIBLE.

The maximum deductible allowed for insurance required by Section 69-206(1), Idaho Code, shall be five thousand dollars (\$5,000). However, a larger deductible may be allowed at the discretion of the Director. (3-15-22)

401. -- 429. (RESERVED)

430. ADDITIONAL BONDING REQUIREMENTS.

~~If it appears the licensee does not have the ability to pay producers for commodities purchased, or when it appears the licensee does not have a sufficient net worth to outstanding financial obligations ratio, the Department may require the licensee to post a bond or other additional acceptable security in the amount of~~ The amount of bond or additional security pursuant to 69-260 is two thousand dollars (\$2,000) for each one thousand dollars (\$1,000) or fraction thereof of deficiency. (3-15-22)()

431. -- 479. (RESERVED)

480. COMMODITY INDEMNITY FUND.

The Commodity Indemnity Fund applies to entities governed by Chapter 2, Title 69, Idaho Code, and Chapter 5, Title 69, Idaho Code, warehouses and dealers, respectively, unless otherwise specified. (3-15-22)

01. Rate of Assessment. The rate of assessment is two-tenths of one percent (.2%) of the total value at the time of sale of the commodities pursuant to Section 69-257(2), Idaho Code. The maximum rate of assessment shall not exceed two-tenths of one percent (.2%) of the total gross dollar amount, without deductions, due the producer. The Director may establish a lower rate of assessment whenever he deems it advisable or as recommended by the advisory committee established by Section 69-261, Idaho Code. (3-15-22)

a. The rate of assessment on commodity withdrawn by its producer from open storage is one cent (\$.01) per hundredweight (CWT) of commodity at the time of withdrawal. (3-15-22)

b. If the amount of the assessment for a producer on all deposits made in a calendar year is calculated to be less than fifty cents (\$.50), no assessment will be collected. If deposits exceed the fifty cent (\$.50) limit, all assessments will be collected. (3-15-22)

02. Exemptions to Assessments. Producers are not eligible to participate in CIF and no assessments can be collected in the following cases. (3-15-22)

a. If a producer has a financial or management interest in a licensed warehouse or licensed commodity dealer, except members of a cooperative marketing association qualified under Title 22, Chapter 26, Idaho Code. (3-15-22)

b. If a producer sells to another producer, none of which are a licensed warehouseman or a licensed commodity dealer. (3-15-22)

c. If a producer deposits or delivers commodity to an unlicensed entity pursuant to Title 69, Chapters 2 or 5, Idaho Code. (3-15-22)

d. Non-producers or producers delivering commodity that was grown on land not situated within the borders of the state of Idaho are exempt from paying assessments. (3-15-22)

481. HOW ASSESSMENTS ARE TO BE CALCULATED.

~~Assessments shall be collected by all warehouses from all producers who deposit commodities for storage or sale.~~ Assessments are calculated as follows: (3-15-22)()

01. Cash Sale or Credit Sale Contract. In a cash sale or credit sale contract on the contract price of the commodity at the time of sale. (3-15-22)

02. Open Storage or Deposit for Service. When commodity is withdrawn from storage by the producer, the assessment will be one cent (\$.01) per hundred weight (CWT) at the time of withdrawal. (3-15-22)

03. Unpaid Assessments. If any assessment is unpaid and a failure occurs, the amount of the unpaid assessment will be deducted from any CIF recovery paid to the producer. (3-15-22)

04. Incidental Costs and Expenses. All incidental costs and expenses including, but not limited to transportation, cleaning, in and out charges, insurance, taxes or additional services or charges are not included in the calculation to determine the assessment. (3-15-22)

482. RECORDKEEPING AND PAYMENT SCHEDULE.

01. Permanent Record. Each warehouse and dealer shall maintain a permanent record showing producer's name and address, lot or identification number, date assessment collected, amount of assessment, commodity assessed, quantity of commodity, gross dollars of settlement and check number issued to producer. (3-15-22)

02. Payment ~~Due Dates~~ of Assessment by Mail. ~~On or before the twentieth day of the month following the close of the quarter, on a form prescribed by the Department, the assessments imposed by Chapters 2 and 5 of Title 69, Idaho Code, collected by warehouses and dealers, are due and payable to the Department. A quarter (1/4) will consist of three (3) months beginning on the first day of January, April, July, and October. If assessment is paid by mail, the payment must be postmarked not later than the twentieth day of the month following the close of the quarter to avoid interest and penalty charges.~~ (3-15-22)()

03. Notice. The notice and rate of assessment or a copy of the official notice of suspension of assessment are to be posted in a conspicuous place in the warehouse or dealer facility. (3-15-22)

483. TRUST FUNDS.

All assessments collected by warehouses and dealers in compliance with Chapters 2 and 5, Title 69, Idaho Code, shall, immediately upon payment to and collection by the warehouse or dealer, be trust fund money and held for payment to the Department for the CIF. Such money shall not, for any purpose, be considered to be a part of the proceeds of any transaction between a depositor and warehouse or dealer for which the collection and payment of the assessment was related and shall not be subject to an encumbrance, security interest, execution or seizure on account

of any debt owed by the warehouse or dealer to any of their creditors. (3-15-22)

484. PENALTIES FOR FAILURE TO COLLECT, ACCOUNT FOR, OR REMIT ASSESSMENTS.

Failure to collect, account for, or remit assessments, or violations of the statutory requirements of Chapters 2 and 5, Title 69, Idaho Code, as it relates to the CIF are grounds for the immediate demand on the warehouse, dealer bond, letter of credit, or certificate of deposit, and the undertaking by the Director of any other remedy provided by law.

(3-15-22)

485. RETURN OF COMMODITY DUE TO FAILURE.

In the event of failure, the Department may:

(3-15-22)()

01. Identifiable Commodity. Return specifically identifiable commodity or as much as is available to its producer in full or partial satisfaction of indebtedness; or (3-15-22)

02. Fungible Commodity. If the commodity is fungible, an amount equal to the producer's original deposit or if insufficient fungible commodity is available, a pro-rata share to all producers of the commodity; and (3-15-22)

03. Shortfall in Commodity Distribution. Any shortfall in commodity distribution may be submitted as a claim against the CIF. (3-15-22)

486. -- 500. (RESERVED)

501. NO PRICE ESTABLISHED (NPE) CONTRACT CLAIMS ON THE FUND.

NPE contracts shall be executed in writing, dated, and signed by all parties to the contract.

(3-15-22)()

01. NPE Clause. An NPE contract shall have the following statement: "No claim shall be paid from the CIF pursuant to Section 69-263, Idaho Code, if a producer files his claim more than one hundred eighty (180) days from the date the contract is executed." (3-15-22)

02. NPE Contract List. A warehouseman shall maintain a list of all NPE contracts written in a calendar year that reflects the producers name, contract number, agricultural commodity, and date of the contract. (3-15-22)

03. NPE Contract Renewal Period. A producer may renew an NPE contract; ~~but no claim shall be paid from the CIF if a producer files his claim more than three hundred sixty five (365) days from the date the original NPE contract was executed.~~ (3-15-22)()

502. -- 999. (RESERVED)

IDAPA 02 – IDAHO STATE DEPARTMENT OF AGRICULTURE

02.02.14 – RULES FOR WEIGHTS AND MEASURES

DOCKET NO. 02-0214-2401

NOTICE OF RULEMAKING – PROPOSED RULE

AUTHORITY: In compliance with Section 67-5221(1), Idaho Code, notice is hereby given that this agency has initiated proposed rulemaking procedures. The action is authorized pursuant to Sections 71-111, Idaho Code.

PUBLIC HEARING SCHEDULE: Public hearing(s) concerning this rulemaking will be scheduled if requested in writing by twenty-five (25) persons, a political subdivision, or an agency, not later than October 16, 2024.

The hearing site(s) will be accessible to persons with disabilities. Requests for accommodation must be made not later than five (5) days prior to the hearing, to the agency address below.

DESCRIPTIVE SUMMARY: The following is a nontechnical explanation of the substance and purpose of the proposed rulemaking:

The proposed rule updates the publication date for the document Incorporated by Reference at Section 004.01. The publication edition is updated to 2024 for the National Institute of Standards and Technology, Handbook No. 44. This handbook contains the specifications, tolerances, and other technical requirements for commercial weighing and measuring devices.

FEE SUMMARY: The following is a specific description of the fee or charge imposed or increased:
There is no change in fee or charge

FISCAL IMPACT: The following is a specific description, if applicable, of any negative fiscal impact on the state General Fund greater than ten thousand dollars (\$10,000) during the fiscal year resulting from this rulemaking:
There is no fiscal impact on the state General Fund greater than ten thousand dollars (\$10,000).

NEGOTIATED RULEMAKING: Pursuant to Section 67-5220(2), Idaho Code, negotiated rulemaking was not conducted because these changes are to the publication dates of documents that were already incorporated into these rules.

INCORPORATION BY REFERENCE: Pursuant to Section 67-5229(2)(a), Idaho Code, the following is a brief synopsis of why the materials cited are being incorporated by reference into this rule:

The referenced NIST Handbook 44 has been updated to the 2024 edition.

IDAHO CODE SECTION 22-101A STATEMENT: Pursuant to 22-101A(1), for any rule promulgated or adopted by the director which is broader in scope or more stringent than federal law or regulations, or which regulates an activity not regulated by the federal government, the director shall identify the portions of the adopted rule that are broader in scope or more stringent than federal law or rules, or which regulate an activity not regulated by the federal government. The following sections of the rule are broader in scope, more stringent than federal law or regulations, or regulate an activity not regulated by the federal government:

This rule regulates an activity that is not regulated by the federal government; therefore the entire rule is broader in scope or more stringent than federal law.

The detailed 22-101A analysis can be found on the agency's website at www.agri.idaho.gov.

ASSISTANCE ON TECHNICAL QUESTIONS, SUBMISSION OF WRITTEN COMMENTS: For assistance on technical questions concerning the proposed rule, contact Lloyd Knight at lloyd.knight@isda.idaho.gov.

Anyone may submit written comments regarding this proposed rulemaking. All written comments must be directed to the undersigned and must be delivered on or before October 23, 2024.

DATED this 2nd day of October, 2024.

Lloyd Knight
Deputy Director
Idaho Department of Agriculture
2270 Old Penitentiary Road
P.O. Box 7249
Boise, Idaho 83707
Phone: (208) 332-8615
Email: lloyd.knight@isda.idaho.gov

THE FOLLOWING IS THE PROPOSED TEXT OF DOCKET NO. 02-0214-2401
(Only Those Sections With Amendments Are Shown.)

02.02.14 – RULES FOR WEIGHTS AND MEASURES

004. INCORPORATION BY REFERENCE.

01. Required Reference Materials. The 2023~~4~~ edition of Handbook No. 44 of the National Institute of Standards and Technology, United States Department of Commerce, “Specifications, Tolerances, and Other Technical Requirements for Weighing and Measuring Devices,” hereby incorporated by reference, is the specifications, tolerances and other technical requirements for commercial weighing and measuring devices, unless otherwise stated in these rules. (7-1-24)()

02. Required Reference Materials for Checking Prepackaged Commodities. The 2020 edition of Handbook No. 133 of the National Institute of Standards and Technology, United States Department of Commerce, “Checking the Net Contents of Packaged Goods,” hereby incorporated by reference, is the authority in checking packaged commodities, unless otherwise stated in these rules. (3-15-22)

~~**03. Specifications for Diesel Fuel and Biodiesel Fuel.** American Society of Testing and Materials (ASTM) D975-20e, “Standard Specification for Diesel Fuel Oils,” and ASTM D6751-20a, “Standard Specification for Biodiesel Fuel (B100) Blend Stock for Distillate Fuels,” intended for blending with diesel fuel are hereby incorporated by reference and are the specifications for diesel fuel and biodiesel fuel blend stock (B100 biodiesel). (3-15-22)~~

~~**04. Specifications for Gasoline.** American Society of Testing and Materials (ASTM) D4814-21, “Standard Specification for Automotive Spark Ignition Engine Fuel”, dated November 15, 2016, is hereby incorporated by reference and is the specification for gasoline. (3-15-22)~~

05. Local Availability. Copies of the incorporated documents are on file with the Idaho State Department of Agriculture, 2216 Kellogg Lane, Boise, Idaho 83712. Copies of NIST documents may be purchased from the Superintendent of Documents, Government Printing Office, Washington, D.C. 20402. Copies are available for downloading at <https://www.nist.gov/pml/weights-and-measures/publications> <https://www.nist.gov/publications/specifications-tolerances-and-other-technical-requirements-weighing-and-measuring-15>. Copies of ASTM specifications are on file with the Idaho State Department of Agriculture or may be purchased from <http://www.astm.org>, 100 Barr Harbor Drive, P.O. Box C700, West Conshohocken, PA, 19428. (3-15-22)()

~~**06. Three Year Tier Fee Table.** Copy may be found online at <https://agri.idaho.gov/main/i-need-to-see-lawsrules/ag-inspections-law-and-rules>. (3-15-22)~~

005. DIESEL, BIODIESEL, AND GASOLINE STANDARDS.

Per Section 37-2506, Idaho Code, the latest specifications adopted by the American Society for Testing and Materials is the required standard for all diesel, biodiesel, and gasoline fuels. The standards can be accessed at <https://www.astm.org/products-services/standards-and-publications/standards/petroleum-standards.html>. ()

0056. -- 009. (RESERVED)

IDAPA 02 – IDAHO STATE DEPARTMENT OF AGRICULTURE

02.03.01 – RULES GOVERNING PESTICIDE MANAGEMENT PLANS FOR GROUND WATER PROTECTION

DOCKET NO. 02-0301-2401 (ZBR CHAPTER REWRITE)

NOTICE OF RULEMAKING – PROPOSED RULE

AUTHORITY: In compliance with Section 67-5221(1), Idaho Code, notice is hereby given that this agency has initiated proposed rulemaking procedures. The action is authorized pursuant to Sections 22-3419, 22-3421, Idaho Code.

PUBLIC HEARING SCHEDULE: Public hearing(s) concerning this rulemaking will be scheduled if requested in writing by twenty-five (25) persons, a political subdivision, or an agency, not later than October 16, 2024.

The hearing site(s) will be accessible to persons with disabilities. Requests for accommodation must be made not later than five (5) days prior to the hearing, to the agency address below.

DESCRIPTIVE SUMMARY: The following is a nontechnical explanation of the substance and purpose of the proposed rulemaking:

This rule is being presented for authorization as part of the ISDA’s plan to review each rule every 5 years. Redundant language that is verbatim in statute has been removed, consistent with the Governor’s [Zero-Based Regulation Executive Order](#).

The rule was reviewed over the course of two negotiated rulemaking meetings, and that review benefited from the participation of program stakeholders. No negative comments were submitted as part of this rulemaking process.

This rule clarifies the procedure for testing and monitoring groundwater for pesticides and remedies of the Department for non-compliance.

FEE SUMMARY: The following is a specific description of the fee or charge imposed or increased: There is no change in fee or charge.

FISCAL IMPACT: The following is a specific description, if applicable, of any negative fiscal impact on the state General Fund greater than ten thousand dollars (\$10,000) during the fiscal year resulting from this rulemaking:

There is no fiscal impact on the state General Fund greater than ten thousand dollars (\$10,000).

NEGOTIATED RULEMAKING: Pursuant to Section 67-5220(1), Idaho Code, negotiated rulemaking was conducted. The Notice of Intent to Promulgate Rules - Negotiated Rulemaking was published in the July 3, 2024 Idaho Administrative Bulletin, [Volume 24-7, Pages 20 and 21](#).

INCORPORATION BY REFERENCE: Pursuant to Section 67-5229(2)(a), Idaho Code, the following is a brief synopsis of why the materials cited are being incorporated by reference into this rule:

There are no changes in documents already incorporated by reference.

IDAHO CODE SECTION 22-101A STATEMENT: Pursuant to 22-101A(1), for any rule promulgated or adopted by the director which is broader in scope or more stringent than federal law or regulations, or which regulates an activity not regulated by the federal government, the director shall identify the portions of the adopted rule that are broader in scope or more stringent than federal law or rules, or which regulate an activity not regulated by the federal government. The following sections of the rule are broader in scope, more stringent than federal law or regulations, or regulate an activity not regulated by the federal government:

The federal government does not regulate this state run program. This activity is defined in Idaho Code.

The detailed 22-101A analysis can be found on the agency’s website at www.agri.idaho.gov.

ASSISTANCE ON TECHNICAL QUESTIONS, SUBMISSION OF WRITTEN COMMENTS: For assistance on technical questions concerning the proposed rule, contact Lloyd Knight at lloyd.knight@isda.idaho.gov.

Anyone may submit written comments regarding this proposed rulemaking. All written comments must be directed to the undersigned and must be delivered on or before October 23, 2024.

DATED this 2nd day of October, 2024.

Lloyd Knight
Deputy Director
Idaho Department of Agriculture
2270 Old Penitentiary Road
P.O. Box 7249
Boise, Idaho 83707
Phone: (208) 332-8615
Email: lloyd.knight@isda.idaho.gov

THE FOLLOWING IS THE PROPOSED TEXT OF DOCKET NO. 02-0301-2401
(ZBR Chapter Rewrite)

02.03.01 – RULES GOVERNING PESTICIDE MANAGEMENT PLANS
FOR GROUND WATER PROTECTION

000. LEGAL AUTHORITY.

~~This chapter is adopted under the legal authority of Sections 22-3418, 22-3419, and 22-3421, Idaho Code.~~

~~(3-31-22)()~~

001. TITLE AND SCOPE.

~~01. Title. The title of this chapter is IDAPA 02.03.01, “Rules Governing Pesticide Management Plans for Ground Water Protection.”~~

~~(3-31-22)~~

~~02. Scope. This chapter establishes a process for responding to pesticide detections in ground water.~~

~~(3-31-22)()~~

002. WRITTEN INTERPRETATIONS.

~~There are no written interpretations of these rules.~~

~~(3-31-22)~~

003. ADMINISTRATIVE APPEALS.

~~There is no provision for administrative appeal before the Idaho Department of Agriculture under this chapter. Hearing and appeal rights are pursuant to Title 67, Chapter 52, Idaho Code.~~

~~(3-31-22)~~

002. -- 003. (RESERVED)

004. INCORPORATION BY REFERENCE.

The following documents are incorporated by reference into this chapter:

(3-31-22)

01. Dimethyl Tetrachloroterephthalate (DCPA) Pesticide Management Plan. The June 2007 edition published by the Idaho State Department of Agriculture. Copies of this document may be obtained from the

Idaho State Department of Agriculture. (3-31-22)

~~005. ADDRESS, OFFICE HOURS, TELEPHONE, FAX NUMBERS, WEB ADDRESS.~~

~~The Idaho State Department of Agriculture central office is located at 2270 Old Penitentiary Road, Boise, ID 83712-8298. The office is open from 8 a.m. to 5 p.m., except Saturday, Sunday, and legal holidays. The mailing address is PO Box 7249, Boise, Idaho 83707. The phone number is (208) 332-8500 and the fax number is (208) 334-2170. The Department web address is <https://agri.idaho.gov/>.~~ (3-31-22)

~~006. PUBLIC RECORDS ACT COMPLIANCE.~~

~~These rules are public records available for inspection and copying at the Department.~~ (3-31-22)

~~007.5. -- 009. (RESERVED)~~

010. DEFINITIONS.

The Idaho Department of Agriculture adopts the definitions set forth in Section 22-3401, Idaho Code, and the following definitions: (3-31-22)

01. Aquifer. A geological unit of permeable saturated material capable of yielding economically significant quantities of water to wells and springs. (3-31-22)

02. Beneficial Uses. Current or future uses of ground water supplies including, but not limited to domestic, industrial, agricultural, aquacultural, and mining. (3-31-22)

03. Best Management Practice. A practice or combination of practices determined to be the most effective and practical means of preventing or reducing pesticide contamination to ground water and interconnected surface water from nonpoint and point sources to achieve water quality goals and protect the beneficial uses of the water. (3-31-22)

04. Constituent. Any chemical, ion, radionuclide, synthetic organic compound, microorganism, waste or other substance occurring in ground water. (3-31-22)

05. Contaminant. Any chemical, ion, radionuclide, synthetic organic compound, microorganism, waste or other substance which does not occur naturally in ground water or which naturally occurs at a lower concentration. (3-31-22)

06. Contamination. The direct or indirect introduction into ground water of any contaminant caused in whole or in part by human activities. (3-31-22)

07. Ground Water. Any water of the state which occurs beneath the surface of the earth in a saturated geological formation of rock or soil. (3-31-22)

08. Health Advisory Level. Guidance for the maximum allowable or acceptable daily concentration of a pesticide in drinking water in the absence of or prior to a MCL being set. (3-31-22)

09. Maximum Contaminant Level. Maximum allowable or acceptable daily concentration of a pesticide in drinking water that may be consumed over a lifetime. (3-31-22)

10. Pesticide Management Standard. The United States Department of Agriculture Natural Resource Conservation Service Conservation Practice Standard, Idaho Pesticide Management Code 595, or the Idaho Agricultural Pollution Abatement Plan -- Pesticide Management Standard Component Practice. (3-31-22)

11. Pesticide Use. The mixing, application, handling, transport, storage, display, distribution, and disposal of pesticides and their containers. (3-31-22)

12. Projected Future Beneficial Uses. Various uses of ground water, such as drinking water, aquaculture, industrial, mining or agriculture, that are practical and achievable in the future based on hydrogeologic conditions, water quality, future land use activities and social/economic considerations. (3-31-22)

13. Reference Dose. Allowable or acceptable dose of a pesticide in terms of mg pesticide/kg body weight that can be ingested in one day (acute reference dose) or on a daily basis over a lifetime (chronic reference dose). (3-31-22)

14. Reference Point. Numerical indicators of the toxicity of a substance based on test data and other reliable health effects information. (3-31-22)

15. Susceptibility. A method of describing the flow of water to, and through, the ground water resource based on physical factors such as hydraulic conductivity, porosity, hydraulic gradients, recharge, interactions with surface water, and transport through the unsaturated zone without considering specific natural or anthropogenic sources of contamination. (3-31-22)

16. Vulnerability. Ground water characterized by a potential for contaminants to enter and be transported within the flow system. Determinations of ground water vulnerability will include consideration of land use practices and aquifer characteristics. (3-31-22)

011. ABBREVIATIONS:

- ~~01. APAP. Agricultural Pollution Abatement Plan. (3-31-22)~~
- ~~02. BMP. Best Management Practice. (3-31-22)~~
- ~~03. DCPA. Dimethyl Tetrachloroterephthalate. (3-31-22)~~
- ~~04. DEQ. Department of Environmental Quality. (3-31-22)~~
- ~~05. EPA. Environmental Protection Agency. (3-31-22)~~
- ~~06. HAL. Health Advisory Level. (3-31-22)~~
- ~~07. MCL. Maximum Contaminant Level. (3-31-22)~~
- ~~08. NRCS. Natural Resources Conservation Service. (3-31-22)~~
- ~~09. PMP. Pesticide Management Plan. (3-31-22)~~
- ~~10. QAPP. Quality Assurance Project Plan. (3-31-22)~~
- ~~11. QMP. Quality Management Plan. (3-31-22)~~
- ~~12. RfD. Reference Dose. (3-31-22)~~
- ~~13. SCC. Soil Conservation Commission. (3-31-22)~~
- ~~14. USDA. United States Department of Agriculture. (3-31-22)~~

~~012~~1. -- 049. (RESERVED)

050. CHEMICAL SPECIFIC PESTICIDE MANAGEMENT PLANS (PMPS).

01. Creating PMPs. The Director shall develop and implement chemical specific PMPs (Section 200) for certain pesticides in geographical areas ~~as determined in Section 400~~ when: (3-31-22)()

a. The level of a pesticide found in ground water is equal to or greater than fifty percent (50%) of the reference point and is scientifically validated; (3-31-22)

b. EPA restricts the sale or use of a pesticide in the state, or otherwise initiates action against a pesticide because of ground water concerns for a pesticide, unless such PMP is not deemed necessary by the Director; (3-31-22)

c. EPA's action, restriction, or prohibition will be implemented unless the state develops an adequate PMP; or (3-31-22)

d. A pesticide is conditionally registered by EPA because of ground water concerns. (3-31-22)

~~02. PMP Compliance. No person shall use a pesticide in a manner inconsistent with the chemical specific PMP within a designated geographical area. (3-31-22)~~

051. -- ~~099~~100. (RESERVED)

100. CONTENTS OF A CHEMICAL SPECIFIC PMP.

~~01. Required Elements of a PMP. (3-31-22)~~

~~a. Actions to prevent pesticide contamination that are based on beneficial uses and vulnerability that address applicable aspects of the pesticide use; and (3-31-22)~~

~~b. Actions to prevent or minimize further presence of the pesticide in ground water and to provide protection for the present and projected future beneficial use of the ground water. (3-31-22)~~

~~02. Elements That May Be Included in a PMP. A PMP may include but is not limited to the following elements: (3-31-22)~~

~~a. Identification of geographical areas where a pesticide may be used; (3-31-22)~~

~~b. Pesticide, soil, hydrogeological, and meteorological characteristics; (3-31-22)~~

~~c. BMPs; (3-31-22)~~

~~d. Identification of ground water areas with pesticide detection(s); (3-31-22)~~

~~e. Certification, licensing, training, and education requirements for persons using the pesticide; (3-31-22)~~

~~f. Identification and establishment of an area of pesticide restriction requiring preventative measures; (3-31-22)~~

~~g. Pesticide application rates and timing and related use criteria; (3-31-22)~~

~~h. Integrated pest management information; (3-31-22)~~

~~i. Other requirements for pesticides, as set forth in the Idaho Pesticide and Chemigation Law (Title 22, Chapter 34, Idaho Code), and IDAPA 02.03.03, "Rules Governing Pesticide and Chemigation Use and Application"; or (3-31-22)~~

~~j. Other requirements as listed by the EPA in rule or guidance. (3-31-22)~~

101. MANAGEMENT PLANS ADOPTED BY RULEMAKING AND REVIEW.

~~01. Adoption Through Rulemaking. The Director shall adopt chemical specific PMPs through rulemaking. (3-31-22)~~

~~02. PMP Review. The Director shall review chemical specific PMPs every two (2) years to determine~~

if the requirements contained in the plans need to be modified based on new scientific data and information. (3-31-22)

102. -- 149. (RESERVED)

150. GROUND WATER QUALITY REFERENCE POINTS.

01. Reference Points. The Director will use reference points for pesticides in ground water, based on the following order of availability: (3-31-22)

a. Idaho rules of DEQ, IDAPA 58.01.11, "Ground Water Quality," Subsection 200.01.a. specific to pesticide primary constituent standards which were adopted from EPA MCLs; or (3-31-22)

b. EPA Health Advisory Levels (HALs) identified in the 2006 Edition of the EPA Drinking Water Standards and Health Advisories, EPA 822-R-06-013; or (3-31-22)

c. EPA Reference Dose (RfD) identified in the 2006 Edition of the EPA Drinking Water Standards and Health Advisories, EPA 822-R-06-013; or (3-31-22)

d. A reference point based on: (3-31-22)

i. Best scientific information currently available on adverse effects of the contaminant(s); and (3-31-22)

ii. Protection of a beneficial use(s); and (3-31-22)

iii. Practical quantitation levels for the pesticides, if they exceed the levels identified in IDAPA 58.01.11, "Ground Water Quality Rule," Subsection 200.01.a. (3-31-22)

02. HAL and RfD Guide. The Director shall use the EPA's HAL and RfD number associated with the effects on a person weighing seventy (70) kilograms and drinking two (2) liters of water per day over a lifetime. (3-31-22)

151. -- 199. (RESERVED)

200. RESPONSE TO A PESTICIDE DETECTION.

~~This section describes the four (4) response levels for responding to pesticide detections in ground water. (3-31-22)~~

01. Level One Response. When a pesticide or its metabolite(s) is detected at or above the detection limit yet below twenty percent (20%) of the reference point, the Director shall notify well users or well owners of pesticide(s) detection and continue ground water monitoring; (3-31-22)()

~~**a.** The Director shall: (3-31-22)~~

~~**i.** Notify well users or well owners of pesticide(s) detection; (3-31-22)~~

~~**ii.** Continue ground water monitoring; (3-31-22)~~

~~**ba.** The Director may: (3-31-22)~~

~~**i.** Provide additional information to pesticide applicators within vulnerable areas; (3-31-22)~~

~~**ii.** Review use practices, soils, hydrogeology, and vulnerability within the area of pesticide detection(s); (3-31-22)~~

~~**iii.** Review state records for previous point source or potential violations in accordance with the Idaho Pesticide and Chemigation Law (Title 22, Chapter 34, Idaho Code); (3-31-22)~~

- iv. Review existing monitoring data within area to check for previous detections; (3-31-22)
 - v. Conduct outreach in local area applicable to relevant data and information; and (3-31-22)
 - vi. Encourage voluntary BMPs consistent with the APAP. (3-31-22)
- 02. Level Two Response.** When a pesticide or its metabolite(s) is detected at twenty percent (20%) to less than fifty percent (50%) of the reference point; (3-31-22)
- ~~a. The Director shall;~~ (~~3-31-22~~)
 - ~~ia.~~ Implement actions in Subsection 200.01 in the area of pesticide detection; (3-31-22)
 - ~~ib.~~ Establish area of pesticide concern, in accordance with Section 400, within area of pesticide detection; (3-31-22)
 - ~~ic.~~ Develop a monitoring plan and monitor to determine trends and fluctuations in pesticide concentrations; (3-31-22)
 - ~~id.~~ Determine likely source(s) while notifying and working with the appropriate parties including but not limited to: pesticide registrant(s), dealer(s), applicator(s) and producer(s) to determine likely source(s); (3-31-22)
 - ~~ie.~~ Determine if pesticide detection(s) is from point or nonpoint source; (3-31-22)
 - ~~if.~~ Promote voluntary BMPs or other measures; evaluate BMP effectiveness, and change BMPs if needed; (3-31-22)
 - ~~ig.~~ Require the utilization of the Idaho NRCS Conservation Practice Standard, Pesticide Management Code 595. (3-31-22)
 - ~~ih.~~ The Director may: (3-31-22)
 - i. Develop a chemical specific PMP per pesticide, unless already mandated through EPA Rule to do so; (3-31-22)
 - ii. Monitor additional domestic wells in the hydrogeological up gradient and down gradient area; and (3-31-22)
 - iii. Conduct site specific pesticide use inspections within the area of detection(s). (3-31-22)
- 03. Level Three Response.** When a pesticide or its metabolite(s) is detected at fifty percent (50%) to less than one hundred percent (100%) of the reference point, the Director shall: (3-31-22)
- ~~a.~~ Implement actions in Subsections 200.02.a. through 200.02.e., and 200.02.g. through 200.02.j. in the area of pesticide detection through 200.02.g in the area of pesticide detection; (~~3-31-22~~)()
 - ~~b.~~ Establish an area of pesticide restriction, in accordance with Section 400 and Section 22-3419, Idaho Code, when the Director determines ground water contamination resulted from the application of a pesticide in accordance with the label; (~~3-31-22~~)()
 - ~~e.~~ Restrict the use of the pesticide according to Section 22-3418, Idaho Code; (3-31-22)
 - ~~ec.~~ Install monitoring wells as soon as possible, if the Director determines installation to be necessary based on severity of risk, to evaluate ground water quality, flow direction, and the effectiveness of preventative measures; (3-31-22)

~~ed.~~ Assist well users or well owners within the area of pesticide restriction with health information and alternative water source information; and (3-31-22)

~~fe.~~ Inspect the pesticide applicator records within the restricted area. (3-31-22)

04. Level Four Response. When a pesticide or its metabolite(s) is detected at or above one hundred percent (100%) of the reference point, the Director shall: (3-31-22)

a. Implement actions in Subsection 200.03 in the area of pesticide detection; (3-31-22)

b. Establish an area of pesticide prohibition, ~~in accordance with Section 400 of this rule and Section 22-3418, Idaho Code,~~ when the Director has determined ground water contamination resulted from the application of a pesticide in accordance with the label; ~~(3-31-22)~~ ()

c. Implement use prohibition area(s); (3-31-22)

d. Assist persons within the use prohibition area with health and alternative water source information; (3-31-22)

e. Determine effectiveness of regulatory actions. (3-31-22)

05. Mixing and Loading Prohibited. No person shall mix or load the prohibited pesticide product in an identified pesticide prohibition area unless the mixing and loading is conducted over a spill containment surface which complies with the Idaho NRCS Conservation Practice Standard, Agrichemical Mixing Facility Code 702. (3-31-22)

~~06. Prohibition Areas.~~ No person shall apply a prohibited pesticide within the corresponding pesticide area boundaries of the area of pesticide prohibition as identified in Section 400. ~~(3-31-22)~~

201. -- 299. (RESERVED)

~~300. GROUND WATER MONITORING PROGRAMS.~~

~~01. Monitoring Programs.~~ The Director shall conduct monitoring programs to: (3-31-22)

~~a.~~ Determine whether residues of pesticides are present in ground water; (3-31-22)

~~b.~~ Refine vulnerability mapping products or other assessment tools; (3-31-22)

~~c.~~ Determine the effectiveness of BMPs; and (3-31-22)

~~d.~~ Determine the effectiveness of regulatory approaches. (3-31-22)

~~02. Conduct Monitoring Programs.~~ The Director shall conduct monitoring programs in compliance with the Department's EPA approved QMP and applicable QAPPs. (3-31-22)

~~03. Evaluation.~~ The Director shall evaluate ground water pesticide(s) data from sources other than the Department for use in implementing this rule. (3-31-22)

~~300.~~ -- 399. (RESERVED)

400. DETERMINING PESTICIDE AREA BOUNDARIES.

~~Section 400 describes the methods for determining the pesticide area boundaries for the response levels in Section 200.~~ (3-31-22)

01. Pesticide Area Boundary Factors. In determining the area of pesticide concern, restricted area, or prohibition area the Director ~~shall implement Section 200 and~~ may consider ~~but not be limited to~~ the following

factors:

~~(3-31-22)~~()

- a. Pesticide detections from reliable ground water test samples; (3-31-22)
- b. Number and frequency of detections; (3-31-22)
- c. Statistical trends of detections; (3-31-22)
- d. Location of detections; (3-31-22)
- e. Hydrogeology of the aquifer; (3-31-22)
- f. Well depth and construction; (3-31-22)
- g. Aquifer vulnerability and susceptibility; (3-31-22)
- h. Pesticide physical and chemical characteristics; (3-31-22)
- i. Pesticide use; or (3-31-22)
- j. Other scientifically defensible information. (3-31-22)

~~**02. Determining Boundaries.** An area of pesticide concern, restricted area, or a prohibition area may encompass land areas which, in the Director's judgment, are susceptible to pesticide contamination of ground water based on the factors identified in Subsection 400.01. The boundaries of an area of pesticide concern, restricted area, or a prohibition area shall be sufficient to meet Section 200 requirements. The boundaries may include any of the following:~~ (3-31-22)

- ~~a. Mapped boundaries between soil types or other hydrogeologic features; (3-31-22)~~
- ~~b. Ground water or surface water divides such as watershed boundaries; (3-31-22)~~
- ~~c. Legal land description boundaries; (3-31-22)~~
- ~~d. Public roads; or (3-31-22)~~
- ~~e. Other recognizable boundaries. (3-31-22)~~

401. -- 409. (RESERVED)

410. REPEALING SPECIFIC PESTICIDE AREAS.

01. Repealing an Area of Pesticide Concern. The Director may repeal or reduce the size of an area of pesticide concern in response to pesticide contamination in ground water if all the following conditions ~~in Subsection 410.01~~ are met: (3-31-22)()

a. Tests on at least three (3) consecutive ground water samples, drawn from each well site in the area of pesticide concern at which the concentration of a pesticide and its metabolites previously were found at twenty percent (20%) to fifty percent (50%) of the reference point, show that the concentration at the well sites has fallen to and remains less than twenty percent (20%) of the reference point. The three (3) consecutive samples shall be collected at each well site at intervals of at least six (6) months, with the first sample being collected at least six (6) months after the effective date of the area of pesticide concern designation. A monitoring well approved by the Director may be substituted for any well site which is no longer available for testing. (3-31-22)

b. Tests conducted at other well sites in the area of pesticide concern during the same retesting period, if any, reveal no other concentrations of the pesticide or its metabolites that exceed twenty percent (20%) of the reference point; and (3-31-22)

c. The Director determines, based on credible scientific evidence, that use of a pesticide product in the area of pesticide concern is not likely to cause a renewed detection between twenty percent (20%) to fifty percent (50%) of the reference point. (3-31-22)

02. Repealing an Area of Pesticide Restriction. The Director may repeal or reduce the size of an area of pesticide restriction in response to ground water pesticide contamination if all the following conditions ~~in Subsection 410.02~~ are met: (3-31-22)()

a. Tests on at least three (3) consecutive ground water samples, drawn from each well site in the area of pesticide restriction at which the concentration of a pesticide and its metabolites previously were found at fifty percent (50%) to less than one hundred percent (100%) of the reference point, show that the concentration at the well sites has fallen to and remains less than fifty percent (50%) of the reference point. The three (3) consecutive samples shall be collected at each well site at intervals of at least six (6) months, with the first sample being collected at least six (6) months after the effective date of the area of the pesticide restriction designation. A monitoring well approved by the Director may be substituted for any well site which is no longer available for testing. As areas of pesticide restriction are repealed, the area automatically becomes an area of pesticide concern; (3-31-22)

b. Tests conducted at other well sites in the area of pesticide restriction during the same retesting period, if any, reveal no other concentrations of the pesticide or its metabolites that exceed fifty percent (50%) of the reference point; and (3-31-22)

c. The Director determines, based on credible scientific evidence, that use of a pesticide product in the area of pesticide restriction is not likely to cause a renewed exceedance of fifty percent (50%) of the reference point. (3-31-22)

03. Repealing an Area of Pesticide Use Prohibition. The Director may repeal or reduce the size of an area of pesticide use prohibition in response to ground water pesticide contamination if all the following conditions ~~in Subsection 410.03~~ are met: (3-31-22)()

a. Tests on at least three (3) consecutive ground water samples, drawn from each well site in the prohibition area at which the concentration of a pesticide and its metabolites previously attained or exceeded the reference point, show that the concentration at that well site has fallen to and remains less than fifty percent (50%) of the reference point. The three (3) consecutive samples shall be collected at each well site at intervals of at least six (6) months, with the first sample being collected at least six (6) months after the effective date of the pesticide use prohibition designation. A monitoring well approved by the Director may be substituted for any well site which is no longer available for testing. As areas of pesticide prohibition are repealed, the area automatically becomes an area of pesticide concern; (3-31-22)

b. Tests conducted at other well sites in the area of pesticide prohibition during the same retesting period, if any, reveal no other concentrations of the pesticide and its metabolites that exceed fifty percent (50%) of the reference point; and (3-31-22)

c. The Director determines, based on credible scientific evidence, that renewed use of a pesticide product in the area of pesticide prohibition is not likely to cause a renewed violation of the reference point. (3-31-22)

~~411.—419.~~ (RESERVED)

~~420. ADVISORY COMMITTEE.~~

~~When pesticide management practices are needed under Section 200, the Director's advisory committee, as established pursuant to Section 22-103, Idaho Code, shall provide appropriate guidance on this rule. This advisory committee shall include but is not limited to: applicators from the area of pesticide detection; pesticide, water user, and commodity groups; University of Idaho Extension staff and specialists; and staff from the USDA, NRCS, SCC, DEQ, and the Department. The duties of the advisory committee include but are not limited to the following:~~

~~(3-31-22)~~

~~01. Review Existing Information.~~ Review the existing information related to the area of pesticide

~~detection and develop pesticide management practices options; (3-31-22)~~

~~**02. Recommendations.** Make recommendations to the Director for approval of pesticide management practices prior to implementation at the voluntary and regulatory levels; (3-31-22)~~

~~**03. Research.** Evaluate the potential for gaining government or private research or cost share funding; and (3-31-22)~~

~~**04. Evaluate Effectiveness.** Review information related to pesticide management practices effectiveness and make recommendations for changing and improving pesticide management practices. (3-31-22)~~

~~**421. PESTICIDE USE AND RECORD KEEPING REQUIREMENTS.**~~

~~Pursuant to Title 22, Chapter 34, Idaho Code, and IDAPA 02.03.03, "Rules Governing Pesticide and Chemigation Use and Application," the Director shall inspect pesticide records to meet the need as described in Section 200. (3-31-22)~~

~~422~~11. -- 999. (RESERVED)

IDAPA 02 – IDAHO STATE DEPARTMENT OF AGRICULTURE

02.04.03 – RULES GOVERNING ANIMAL INDUSTRY

DOCKET NO. 02-0403-2401 (ZBR CHAPTER REWRITE)

NOTICE OF RULEMAKING – PROPOSED RULE

AUTHORITY: In compliance with Section 67-5221(1), Idaho Code, notice is hereby given that this agency has initiated proposed rulemaking procedures. The action is authorized pursuant to Sections 69-231, 22-3418, 22-3419, 22-3421, 22-103 (20), 25-203, 25-207, 25-207B, 25-212, 25-804, 25-3704, 22-5404, Idaho Code.

PUBLIC HEARING SCHEDULE: Public hearing(s) concerning this rulemaking will be scheduled if requested in writing by twenty-five (25) persons, a political subdivision, or an agency, not later than October 16, 2024.

The hearing site(s) will be accessible to persons with disabilities. Requests for accommodation must be made not later than five (5) days prior to the hearing, to the agency address below.

DESCRIPTIVE SUMMARY: The following is a nontechnical explanation of the substance and purpose of the proposed rulemaking:

This rule is being presented for authorization as part of the ISDA’s plan to review each rule every 5 years. Redundant language that is verbatim in statute has been removed, consistent with the Governor’s [Zero-Based Regulation Executive Order](#).

The rule was reviewed over the course of two negotiated rulemaking meetings, and that review benefited from the participation of program stakeholders. No negative comments were submitted as part of this rulemaking process.

This rule clarifies the procedure for disease control of livestock and other animals into, within, and out of the state, procedures for prevention, control, and eradication of diseases among animals in the state of Idaho, and remedies of the Department for non-compliance.

FEE SUMMARY: The following is a specific description of the fee or charge imposed or increased:

There is no change in fee or charge.

FISCAL IMPACT: The following is a specific description, if applicable, of any negative fiscal impact on the state General Fund greater than ten thousand dollars (\$10,000) during the fiscal year resulting from this rulemaking:

There is no fiscal impact on the state General Fund greater than ten thousand dollars (\$10,000).

NEGOTIATED RULEMAKING: Pursuant to Section 67-5220(1), Idaho Code, negotiated rulemaking was conducted. The Notice of Intent to Promulgate Rules - Negotiated Rulemaking was published in the July 3, 2024 Idaho Administrative Bulletin, [Volume 24-7, Pages 41 and 42](#).

INCORPORATION BY REFERENCE: Pursuant to Section 67-5229(2)(a), Idaho Code, the following is a brief synopsis of why the materials cited are being incorporated by reference into this rule:

The Incorporation by Reference Section has been updated to remove four documents that are unnecessary in the rule as they are already included in the Code of Federal Regulations as they are federal program diseases, included in Idaho Code, or include standards that are impractical.

The following documents are no longer referenced:

- A. The USDA Pseudorabies Eradication State Federal Industry Program Standards
- B. National Poultry Improvement Plant and Auxiliary Provisions
- D. The Compendium of Animal Rabies Prevention and Control
- E. Equine Viral Arteritis Uniform Methods and Rules

IDAHO CODE SECTION 22-101A STATEMENT: Pursuant to 22-101A(1), for any rule promulgated or adopted by the director which is broader in scope or more stringent than federal law or regulations, or which regulates an activity not regulated by the federal government, the director shall identify the portions of the adopted rule that are broader in scope or more stringent than federal law or rules, or which regulate an activity not regulated by the federal government. The following sections of the rule are broader in scope, more stringent than federal law or regulations, or regulate an activity not regulated by the federal government:

The federal government only provides standards and best practices for certain diseases and programs implemented under this rule. The federal government does not regulate animals within the state. This activity is defined in Idaho Code.

The detailed 22-101A analysis can be found on the agency’s website at www.agri.idaho.gov.

ASSISTANCE ON TECHNICAL QUESTIONS, SUBMISSION OF WRITTEN COMMENTS: For assistance on technical questions concerning the proposed rule, contact Lloyd Knight at lloyd.knight@isda.idaho.gov.

Anyone may submit written comments regarding this proposed rulemaking. All written comments must be directed to the undersigned and must be delivered on or before October 23, 2024.

DATED this 2nd day of October, 2024.

Lloyd Knight
Deputy Director
Idaho Department of Agriculture
2270 Old Penitentiary Road
P.O. Box 7249
Boise, Idaho 83707
Phone: (208) 332-8615
Email: lloyd.knight@isda.idaho.gov

THE FOLLOWING IS THE PROPOSED TEXT OF DOCKET NO. 02-0403-2401
(ZBR Chapter Rewrite)

02.04.03 – RULES GOVERNING ANIMAL INDUSTRY

000. LEGAL AUTHORITY.

~~This chapter is adopted under the legal authority of~~ Sections 22-103(20), 25-203, 25-207, 25-207B, 25-212, and 25-804, 25-3704 Idaho Code. ~~(3-15-22)()~~

001. ~~TITLE AND SCOPE.~~

~~01. Title.~~ The title of this chapter is “Rules Governing Animal Industry.” ~~(3-15-22)~~

~~02. Scope.~~ These rules govern procedures for the prevention, control and eradication of diseases among the animals in the state of Idaho and the declaration of an animal health emergency. ~~(3-15-22)()~~

002. -- 010. (RESERVED)

011. ABBREVIATIONS.

- 01. APHIS. Animal and Plant Health Inspection Service. (3-15-22)
- 02. CFR. Code of Federal Regulations. (3-15-22)
- 03. CVI. Certificate of Veterinary Inspection. ()
- 04. NASAHO. National Assembly of State Animal Health Officials. ()
- 035. USDA. United States Department of Agriculture. (3-15-22)
- 046. VS. Veterinary Services. (3-15-22)
- 102. -- 103. (RESERVED)

SUBCHAPTER A – ANIMAL INDUSTRY

104. INCORPORATION BY REFERENCE.

The following documents are incorporated by reference and apply only to Subchapter A, Sections 110-460: (3-15-22)

- 01. **Incorporated Documents.** (3-15-22)
 - a. The USDA Pseudorabies Eradication State-Federal-Industry Program Standards, November 1, 2003, which can be viewed online at http://www.aphis.usda.gov/animal_health/animal_diseases/pseudorabies/downloads/program_std.pdf ~~https://www.aphis.usda.gov/sites/default/files/prv_program_standards.pdf~~. (3-15-22)()
 - b. ~~National Poultry Improvement Plan and Auxiliary Provisions, February 12, 2008, which can be viewed online at <http://edocket.access.gpo.gov/2009/E9-7240.htm>.~~ (3-15-22)
 - c. Title 9, Parts ~~145, 146, 147, and~~ 161, CFR, January 1, 2008~~24~~, which can be viewed online at <https://www.govinfo.gov/content/pkg/CFR-2008-title9-vol1/pdf/CFR-2008-title9-vol1-chap1.pdf> ~~<https://www.ecfr.gov/current/title-9/chapter-I/subchapter-J/part-161>~~. (3-15-22)()
 - d. ~~The Compendium of Animal Rabies Prevention and Control, 2008, which can be viewed online at <http://www.nasphv.org/Documents/NASPHVRabiesCompendium.pdf>.~~ (3-15-22)
 - e. ~~Equine Viral Arteritis Uniform Methods and Rules, April 19, 2004, which can be viewed online at <http://www.aphis.usda.gov/vs/nahss/equine/eva/eva-umr.pdf>.~~ (3-15-22)

105. -- 109. (RESERVED)

110. DEFINITIONS.

~~In addition to the definitions found in Idaho Code Sections 25-239 and 25-802,~~ The definitions in Section 110 apply in the interpretation and enforcement of Subchapter A only: (3-15-22)()

- 01. **Accredited Veterinarian.** A veterinarian approved by the Administrator and USDA/APHIS/VS, in accordance with the provisions of Title 9, Part 161, Code of Federal Regulations, ~~to perform functions of State-Federal animal disease control programs.~~ (3-15-22)()
- 02. **Animal.** Any vertebrate member of the animal kingdom, except man. (3-15-22)
- 03. **Approved Pseudorabies Vaccine.** Any pseudorabies vaccine produced under current USDA license and intended for immunizing swine against pseudorabies. (3-15-22)
- 04. **Cachexia.** Weakness and emaciation caused by a serious disease such as tuberculosis or cancer.

- (3-15-22)
- 05. Epithelioma.** Cancer or tumor. (3-15-22)
- 06. Equidae.** Horses, ponies, mules, asses, and zebras. (3-15-22)
- 07. Exposed Livestock.** Any livestock that have been in contact with an animal infected with, or affected by, any contagious, infectious or communicable disease, including all livestock in a known infected herd. (3-15-22)
- 08. Gamebirds.** Domesticated gallinaceous fowl such as pheasants, partridge, quail, grouse, and guineas. (3-15-22)
- 09. Garbage.** Putrescible animal and vegetable waste containing animal parts resulting from the handling, preparation, processing, cooking or consumption of foods. (3-15-22)
- 10. Hatching Eggs.** Fertilized eggs. (3-15-22)
- 11. Herd.** ~~A herd is a~~ Any group of livestock maintained on common ground for any purpose, or two (2) or more groups of livestock under common ownership or supervision, geographically separated, but which have an interchange or movement of animals without regard to whether the animals are infected with or exposed to contagious, infectious, or communicable animal diseases. (~~3-15-22~~)()
- 12. Infected Livestock.** Any herd of livestock or individual animal determined to be infected with a contagious, infectious, ~~of or~~ communicable disease by an official test or diagnostic procedure, or diagnosed by a veterinarian as infected. (~~3-15-22~~)()
- 13. Interstate Movement.** Movements of livestock and poultry from Idaho into any other state, territory or the District of Columbia or from any other state, territory or the District of Columbia into Idaho. (3-15-22)
- 14. Intrastate Movement.** Movement of any animal from one location to another location within Idaho. (3-15-22)
- ~~**15. Known Infected Herd.** Any herd in which any livestock has been determined to be infected with contagious, infectious, or communicable diseases by an official test or diagnostic procedure, or diagnosed by a veterinarian as being infected. (3-15-22)~~
- 165. Livestock.** Swine, cattle, sheep, goats, equidae, domestic bison, domestic cervidae, camelids, ratites, and other domestically raised animals. (3-15-22)
- ~~**176. Necrosis.** Death of tissue. (3-15-22)~~
- ~~**187. Negative.** An animal that has been tested with official test procedures and is found to be negative. (3-15-22)~~
- ~~**198. Neoplastic Tissue.** New growth or tissue associated with a tumor. (3-15-22)~~
- ~~**2019. Official Pseudorabies Test.** Any test for the diagnosis of pseudorabies that has been approved by USDA/APHIS and is conducted by a state/federal approved laboratory. (3-15-22)~~
- ~~**240. Orbital Region.** The cavity containing the eye and surrounding bones. (3-15-22)~~
- 221. Positive.** An animal that has been tested and ~~found~~ confirmed positive with official disease test procedures and is considered infected with any contagious, infectious, or communicable disease. (~~3-15-22~~)()
- ~~**232. Poultry.** Domesticated fowl, including chickens, turkeys, waterfowl, and gamebirds. (3-15-22)~~

243. Pseudorabies. The contagious, infectious, and communicable disease of livestock and other animals also known as Aujeszky's disease, mad itch or infectious paralysis. (3-15-22)

254. Quarantine. A written order, or a verbal order followed by a written order, executed by the Administrator, to confine or hold animals on a premise or any other location, and to prevent movement of animals from a premise or any other location when the Administrator has determined that the animals have been found or are suspected to be exposed to or infected with any contagious, infectious, or communicable disease, or the animals are not in compliance with the provisions of this chapter. (3-15-22)

265. Quarantined Area. The counties, areas, or districts, portions thereof, quarantined by the Division of Animal Industries for specific contagious, infectious, or communicable animal diseases. (3-15-22)

276. Quarantined. Isolation of all animals diseased or exposed thereto, from contact with healthy animals and exclusion of such healthy animals from enclosures or grounds where said diseased or exposed animals are, or have been kept. (3-15-22)

287. Ratites. Large, non-flying birds including, but not limited to ostriches, emus, cassowaries, and rheas. (3-15-22)

~~**29. Registered Veterinarians.** Veterinarians registered with, and approved by, the Division of Animal Industries to collect Trichomoniasis samples for official Trichomoniasis culture testing. (3-15-22)~~

~~**3028. Restrain.** The confinement of livestock, or other animals, in a chute, or other device, for the purpose of efficiently, effectively, and safely inspecting, treating, vaccinating, or testing, as approved by the Administrator. (3-15-22)~~

~~**3429. Stockyards.** A facility where trading in livestock is carried on, where yarding, feeding and watering places are provided by the stockyards or transportation companies, or where livestock associations or similar companies maintain corrals for feeding, shearing, dipping and separating animals. (3-15-22)~~

320. Suppuration. The formation of pus. (3-15-22)

~~**331. Suspect.** An animal that has a response to an official test, but the response is not sufficient to determine confirm the disease status of the animal tested. (3-15-22)()~~

342. Swine. All breeds of domestic porcine and all wild and exotic porcine. (3-15-22)

353. Swine Feedlot. Premises designed and used exclusively for the finish feeding of swine, from which the swine will be moved directly to slaughter. (3-15-22)

364. Waterfowl. Domesticated fowl that normally swim such as ducks and geese. (3-15-22)

~~**37. Wildfowl.** Wild gallinaceous fowl, turkeys, and waterfowl. (3-15-22)~~

111. ABBREVIATIONS.

01. AGID. Agar gel immunodiffusion. (3-15-22)

02. c-ELISA. Competitive Enzyme Linked Immunosorbent Assay. (3-15-22)

03. EIA. Equine Infectious Anemia. (3-15-22)

04. NPIP. National Poultry Improvement Plan. (3-15-22)

112. -- 113. (RESERVED)

114. SAMPLES FOR OFFICIAL REGULATORY TESTS.

No person shall collect samples, in Idaho, for official regulatory tests except: (3-15-22)

01. **Accredited Veterinarians.** (3-15-22)
02. **State or Federal Animal Health Officials.** (3-15-22)
03. **Persons Approved by the Administrator.** (3-15-22)

~~115. QUARANTINE.~~

~~The Administrator and all state and federal animal health officials are authorized to quarantine any animals affected or infected with, or exposed to any contagious, infectious, or communicable disease where such animals are found, or quarantine to a place designated by the Administrator. (3-15-22)~~

~~01. **Written Notice.** The owner or person in charge of the quarantined animals shall be given written notice of the quarantine. (3-15-22)~~

~~02. **Acknowledgment of Quarantine.** A quarantine is valid whether or not it is acknowledged by the signature of the owner or person in charge of the quarantined animals. (3-15-22)~~

~~03. **Disposition of Quarantined Animals.** No quarantined animals shall be moved, treated, or disposed of without the written approval of the Administrator. (3-15-22)~~

~~04. **Hold Order.** A hold order is a form of quarantine that may be used to restrict the movement of animals while the disease status of the animals is being investigated. (3-15-22)~~

~~116.5 -- 119. (RESERVED)~~

120. DISINFECTION OF PREMISES, BUILDINGS AND VEHICLES.

The Administrator is authorized to order the cleaning and disinfecting of any ~~barns, sheds, stockyards, railroad cars, ferryboats and other vehicles, feed yards, stable, pens, corrals, lanes and premises~~ facilities, equipment, or vehicles which have been used in confining, ~~trailing~~ handling, or transporting any animals exposed to, affected by, or infected with any contagious, infectious, or communicable diseases. (3-15-22)()

01. **Supervision of Cleaning and Disinfection.** State or federal animal health officials may supervise and/or verify the cleaning and disinfecting of such premises or conveyances. (3-15-22)()

02. **Owner Responsibility.** The owner of such premises or conveyances, is responsible for cleaning and disinfecting when directed to do so by the Administrator. (3-15-22)

~~03. **Moving Contaminated Vehicle.** Any conveyance that has contained cattle, swine or other livestock exposed to, or affected by, any contagious, infectious or communicable disease, may not be moved for any purpose unless the Administrator has approved the movement in writing, prior to the movement occurring. (3-15-22)~~

~~04. **Yards and Other Premises.** Yards and other premises which have contained cattle, swine or other livestock exposed to, or affected by, any contagious, infectious or communicable disease shall not be used in connection with the movement of healthy animals until the said yards and premises have been cleaned and disinfected, under state or federal supervision, as directed by the Administrator. (3-15-22)~~

~~053. **Disinfectants.** Only disinfectants approved by USDA or the Administrator may be used. (3-15-22)~~

~~121. -- 124. (RESERVED)~~

~~125. TRANSIT INSPECTION.~~

~~When deemed necessary, movements of animals will be stopped in transit for inspection. If the animals are suspected of being infected with or exposed to any contagious, infectious or communicable disease, all persons having control of the transportation or movement of the animals shall cease the movement of the animals upon receipt of an order~~

~~from state or federal animal health officials.~~

~~(3-15-22)~~

~~126. — 129. (RESERVED)~~

130. SLAUGHTERING OF DISEASED ANIMALS.

01. Authorized by Law. When, in order to prevent the spread of contagious, infectious or communicable disease, it becomes necessary to slaughter any diseased or exposed livestock, the purchase of such livestock by the state is authorized by law, and an appropriation is available therefore, the value of the livestock is ascertained and compensation made therefore in accordance with the rules hereinafter provided. (3-15-22)

02. Not Authorized by Law. When, in order to prevent the spread of or to eradicate any contagious, infectious or communicable disease among any animals of this state, it becomes necessary to slaughter or destroy any diseased or exposed animals, and the purchase of such animals by the state is not authorized, and an appropriation not available therefore, the said animals shall be slaughtered under federal meat inspections rules and regulations, or destroyed and disposed of in accordance with IDAPA 02.04.17, "Rules Governing Dead Animal Movement and Disposal." (3-15-22)

~~131. -- 139. (RESERVED)~~

140. INSPECTION OF ANIMALS.

~~When animals are being inspected by a state or federal animal health official, proper facilities for restraining the animals, and assistance shall be provided by the owner in order that a careful inspection may be made, and state and federal animal health officials shall not be interfered with in any manner. The owner of any animal being inspected shall assist, in any manner required, state or federal health officials and shall not interfere with the inspection.~~

~~(3-15-22)()~~

~~141. -- 144. (RESERVED)~~

145. CERTIFICATES OF VETERINARY INSPECTION.

A physical or electronic copy of ~~certificates~~ CVIs issued by an accredited veterinarian, ~~or a state or federal animal health official covering the movement of livestock~~ shall accompany the livestock to its' destination, ~~and be provided to the receiver of the livestock by the person who delivers the livestock.~~

~~(3-15-22)()~~

01. Copies Approved Certificates. ~~Legible copies of All~~ certificates of veterinary inspection ~~shall be submitted to the Division of Animal Industries~~ must be an electronic CVI approved by the NASAHO and issued by an accredited veterinarian.

~~(3-15-22)()~~

02. Idaho Certificates. ~~Accredited veterinarians in Idaho shall submit legible copies of all certificates that they issue to the Division of Animal Industries within five (5) business days of issuance.~~

~~(3-15-22)~~

~~146. -- 149. (RESERVED)~~

150. STATE AND FEDERAL SEALS.

No person may break, or in any way tamper with, a seal or other device applied to premises or conveyances by state or federal animal health officials, except: (3-15-22)

01. State or Federal Animal Health Officials; or (3-15-22)

02. Persons Designated by the Administrator. (3-15-22)

151. NOTIFICATION OF BROKEN SEALS.

Any person who discovers a state or federal seal that has been broken, tampered with, or is missing shall immediately notify the Administrator. (3-15-22)

152. LIVESTOCK IDENTIFICATION REMOVAL.

No person, except persons authorized by the Administrator, may remove or tamper with any state or federal livestock

identification, including but not limited to: (3-15-22)

01. Official Vaccination Tags. (3-15-22)

02. Official Identification Tags. (3-15-22)

03. Trichomoniasis Tags. (3-15-22)

04. Identification Tattoos. (3-15-22)

153. -- 199. (RESERVED)

200. ARTIFICIAL INSEMINATION.

01. **License Application.** Any person desiring to practice artificial insemination of domestic animals may file an application for a license on an application form furnished by the Administrator and accompanied by a license fee of twenty-five (\$25) dollars. (3-15-22)

~~02. **Training.** Each applicant is required to take a course of training in artificial insemination at the place and time designated by the Administrator. (3-15-22)~~

~~03. **Examination.** Examinations are in writing and focused on the skill of artificial insemination. (3-15-22)~~

~~04. **Passing Examination.** To be granted a license to practice artificial insemination applicants must answer correctly seventy-five percent (75%) of all questions asked. (3-15-22)~~

05. **Temporary License.** Temporary license to practice artificial insemination under the direct supervision of a licensed inseminator or veterinarian may be granted by the administrator, until such time as the next insemination course and examination is given. (3-15-22)

06. **License Expiration.** Licenses expire on the 30th day of June of each year, and all persons holding a license shall renew their license on or before the 1st day of July of each year. (3-15-22)

07. **License Renewal.** Each license renewal is to be addressed to the Administrator and accompanied by a renewal license fee of five dollars (\$5). (3-15-22)

08. **Renewal Delinquency.** Licenses not renewed by the 1st day of October following the date of delinquency are canceled. (3-15-22)

09. **Issuance Denial.** The Administrator may refuse to issue or renew a license pursuant to Section 25-810, Idaho Code. (3-15-22)

201. -- 209. (RESERVED)

210. CANCER EYE - EPITHELIOMA.

Any animal offered for sale and found to be affected with epithelioma of the eye or of the orbital region ~~in which the eye has been destroyed or obscured by neoplastic tissue and which shows extensive infection, suppuration and necrosis, usually accompanied with foul odor, or any animal affected with epithelioma of the eye or the orbital region which, regardless of extent, is accompanied with cachexia shall not be sold for slaughter for human consumption. All such animals~~ shall be humanely euthanized, or disposed of for immediate slaughter directly to: (3-15-22)()

01. Animal Rendering Plants; or (3-15-22)

02. Fur Farms. Fur or mink farm or other establishment as approved by the Administrator. (3-15-22)

211. EPITHELIOMA -- PUBLIC LIVESTOCK MARKETS.

Any animal entering a public livestock market that is affected, as described in Section 210 of this rule, shall be held only in the quarantine pen and sold only there from. (3-15-22)

~~212. -- 219. (RESERVED)~~

~~220. RABIES.~~

~~The Administrator is authorized to develop and implement a plan for rabies control in any portion of this state. (3-15-22)~~

~~01. Reporting. It is hereby made the duty of all persons practicing veterinary medicine in this state, or owners or persons in charge of animals, to report to the Administrator, by telephone, facsimile, or electronic mail, all cases of rabies within forty-eight (48) hours. (3-15-22)~~

~~02. Discharging Authority. State and federal animal health officials are authorized and empowered to: (3-15-22)~~

~~a. Inspect, quarantine, treat, condemn, slaughter and dispose of any animals affected or infected with or exposed to rabies. (3-15-22)~~

~~b. Quarantine, clean and disinfect all premises where such animals have been kept. (3-15-22)~~

~~c. Call upon sheriffs, constables and other peace officers to assist them in the discharge of their duties. (3-15-22)~~

~~221.—229. (RESERVED)~~

~~230. BIOLOGICALS.~~

~~Veterinary serums, vaccines, recombinant vaccines, bacterins, biologic remedies, diagnostic agents, immunoassay agents and diagnostic probes (“biologicals”) used in the treatment or diagnosis of disease of livestock, poultry, domestic animals, fish or fur bearing animals shall not be imported into or sold, distributed, or used within the state of Idaho unless such serum, vaccines, recombinant vaccines, bacterins, biologic remedies, diagnostic agents, immunoassay agents and diagnostic probes biologicals have been produced under a license by the United States Department of Agriculture and the manufacturers shall have a permit issued by the Idaho Department of Agriculture, Division of Animal Industries. (3-15-22)()~~

~~231. -- 239. (RESERVED)~~

~~240. POULTRY AND RATITES.~~

~~Any person producing poultry or ratites for any of the following uses, is required to be in compliance with the NPIP program: (3-15-22)~~

~~01. Sale of Live Birds or Hatching Eggs. The sale of live birds or hatching eggs; or (3-15-22)~~

~~02. Release of Live Birds. Release of live birds, such as hunting clubs, hunting preserves, or dog trials; or the release of live birds into the wild. (3-15-22)~~

~~241. RECORD REQUIREMENTS.~~

~~In addition to meeting the record keeping requirements of the NPIP program, all NPIP participants shall forward a copy of their annual flock qualification test results to the Division of Animal Industries within fifteen (15) days of the completion of testing. (3-15-22)~~

~~242. INSPECTIONS.~~

~~The premises where participants in the NPIP program raise poultry or ratites shall be inspected at least once each calendar year by state or federal animal health officials. (3-15-22)~~

~~01. Scheduling of Inspections. State or federal animal health officials will attempt to notify the NPIP participant prior to any inspection and schedule the annual inspections in advance with the NPIP participant.~~

(3-15-22)

~~02. **Inspecting Records.** During normal business hours, state or federal animal health officials are authorized to inspect, review, and copy any poultry or ratite records deemed necessary to ensure compliance with these rules. State or federal animal health officials will attempt to notify the owner or operator of the premises where records are kept prior to inspecting records.~~ (3-15-22)

~~243. **NPIP CERTIFICATES OF PARTICIPATION.**~~

~~The Division of Animal Industries will issue NPIP participation certificates annually to the owners of poultry and ratites that meet the following requirements:~~ (3-15-22)

~~01. **Records.** Each NPIP participant must have on file records of their flock qualification testing; and~~ (3-15-22)

~~02. **Inspection Forms.** Each NPIP participant shall have on file a copy of the annual inspection form from the previous year documenting compliance with the NPIP program.~~ (3-15-22)

~~244.—249. (RESERVED)~~

250. EQUIDAE -- EQUINE INFECTIOUS ANEMIA.

Official tests for EIA include the AGID test, the C-ELISA test, and other EIA tests approved by USDA or the Administrator. (3-15-22)

01. Blood Samples. Equine blood samples collected for official EIA tests shall be collected by a state or federal animal health official or an accredited veterinarian who is licensed in the state in which the animal being tested is located. (3-15-22)

02. Official Samples. Official EIA test samples shall be accompanied to the testing laboratory by an official EIA test report on submission form approved by USDA or the Administrator which ~~is recorded the name and address of the owner or person in charge of the animal, the breed, sex, age and~~ includes the physical description and identification of the animal being tested. ~~Identification includes identifying tattoos, brands, color and distinctive markings. The accredited veterinarian or animal health official collecting the EIA test samples shall record the date the samples were collected and affix his signature to the official EIA test report.~~ (3-15-22)()

03. Official Tests. Official EIA tests shall be conducted in a laboratory approved by USDA or the state of Idaho to conduct EIA tests. (3-15-22)

251. EIA IS A REPORTABLE DISEASE.

All laboratories conducting EIA tests on Idaho origin equidae ~~and all veterinarians who diagnose EIA in Idaho equidae~~ shall report positive results of all EIA tests ~~and diagnoses~~ to the Administrator of Animal Industries within twenty-four (24) hours of such test or diagnosis. ~~Negative test results shall be reported within forty eight (48) hours.~~ (3-15-22)()

252. EIA INFECTED ANIMALS.

Any equidae which are positive to an official EIA test are to be declared infected with EIA and designated as an EIA reactor. The Administrator may require or recommend a re-test of EIA reactors in order to confirm infection or identification of the animal. In cases where a confirmatory test is conducted, the final determination of infection will be delayed until the results of the confirmatory test are available. The animal on which a confirmatory test is to be conducted will be placed under an official Hold Order until the results of the confirmatory test are available. (3-15-22)

253. DISPOSITION OF EIA REACTORS.

Equidae found to be infected with EIA shall: (3-15-22)

01. Quarantined. Be quarantined to the premises where the animal was found to be infected, the owner's premises, or another premises that is approved by the Administrator. (3-15-22)

- 02. Duration of Quarantine.** Remain under quarantine until it is: (3-15-22)
- a.** Consigned to slaughter at a USDA approved equine slaughter establishment; or (3-15-22)
 - b.** Euthanized and buried or incinerated; or (3-15-22)
 - c.** Donated to a university or other research facility for use in EIA research projects. (3-15-22)

254. ISOLATION OF EIA REACTORS.

The quarantine premises or area for EIA reactors shall provide no less than two-hundred (200) yards separation from all other equidae. The quarantine area and quarantined animals therein may be monitored periodically by state or federal animal health officials to ensure that provisions of the quarantine are being met. (3-15-22)

255. IDENTIFICATION OF EIA REACTORS.

All equidae found to be infected with EIA shall be identified with an “82 A”, at least two (2) inches high, hot iron or freeze brand on the left neck or left shoulder of the animal. Identification as an EIA reactor shall be accomplished within fifteen (15) days of notification that the animal is infected with EIA. (3-15-22)

256. EXPOSED EQUIDAE.

EIA exposed equidae may include all equidae that are held within two-hundred (200) yards of the location where an EIA reactor is or was maintained. (3-15-22)

01. Hold Order. Exposed equidae shall be placed under a Hold Order until the animals have been tested negative to EIA at least sixty (60) days after the last reactor animal has been removed from the premises. (3-15-22)

02. Movement of Exposed Equids. Individual exposed equids, which have not had a negative sixty (60) day test, may be allowed to move under Hold Order for specific purposes if they have a negative EIA test prior to movement. Such movement shall not be for longer than fifteen (15) days. (3-15-22)

257. EXTENDED VALIDITY EQUINE CERTIFICATES.

~~Provided there is a written agreement between the Administrator and the chief livestock sanitary official of the state of destination, Idaho origin equidae may be moved from Idaho for shows, rides, or other equine events and return to Idaho on an extended validity equine certificate under a state system of equine certification acceptable to the Administrator and the state of destination. The Administrator may authorize the movement of equidae into or out of Idaho on extended validity equine certificates~~ system approved by the Administrator. (3-15-22)()

258. -- 299. (RESERVED)

300. FOREIGN ANIMAL AND REPORTABLE DISEASES.

It is the duty of all persons in Idaho to immediately report to the Administrator ~~immediately, by telephone, facsimile, or electronic mail,~~ any lesions or symptoms resembling any of the foreign animal and reportable diseases listed in Subchapter A, ~~that they may find existing among the~~ if observed in any animals in Idaho. The Administrator may add a foreign animal and reportable disease by issuing an administrative order explaining in writing the reasons for requiring the disease to be reported. (3-15-22)()

301. FOREIGN ANIMAL AND REPORTABLE DISEASES: MULTIPLE SPECIES.

- 01. Anthrax.** (3-15-22)
- 02. Brucellosis.** (3-15-22)
- 03. Foot and Mouth Disease.** (3-15-22)
- 04. Heartwater.** (3-15-22)
- 05. Leishmaniasis.** (3-15-22)

- 06. Plague (*Yersinia pestis*). (3-15-22)
- 07. Pseudorabies. (3-15-22)
- 08. Q Fever (*Coxiella burnetti*). (3-15-22)
- 09. Rabies. (3-15-22)
- 10. Rift Valley Fever. (3-15-22)
- 11. Scabies. (3-15-22)
- 12. Screw Worms. (3-15-22)
- 13. Theileriosis. (3-15-22)
- 14. Trypanosomiasis. (3-15-22)
- 15. Tuberculosis. (3-15-22)
- 16. Tularemia. (3-15-22)
- 17. Vesicular Stomatitis. (3-15-22)
- 302. FOREIGN ANIMAL AND REPORTABLE DISEASES: AVIAN DISEASES.**
- 01. Avian Influenza. (3-15-22)
- 02. Avian Chlamydiosis (*Psittacosis*). (3-15-22)
- 03. Exotic Newcastle Disease. (3-15-22)
- 303. FOREIGN ANIMAL AND REPORTABLE DISEASES: BOVINE DISEASES.**
- 01. Babesiosis. (3-15-22)
- 02. Bovine Brucellosis (*B. abortus*). (3-15-22)
- 03. Bovine Spongiform Encephalopathy. (3-15-22)
- 04. Bovine Tuberculosis. (3-15-22)
- 05. Contagious Bovine Pleuropneumonia. (3-15-22)
- 06. Crimean Congo Hemorrhagic Fever. (3-15-22)
- 07. Lumpy Skin Disease. (3-15-22)
- 08. Malignant Catarrhal Fever (Foreign Type). (3-15-22)
- 09. Rinderpest. (3-15-22)
- 10. Trichomoniasis. (3-15-22)
- 304. FOREIGN ANIMAL AND REPORTABLE DISEASES: CERVIDAE DISEASES.**
- Chronic Wasting Disease is a reportable disease. (3-15-22)

305. FOREIGN ANIMAL AND REPORTABLE DISEASES: EQUINE DISEASES.

- 01. African Horse Sickness. (3-15-22)
- 02. Contagious Equine Metritis. (3-15-22)
- 03. Dourine. (3-15-22)
- 04. Equine Encephalomyelitis (Eastern, Western, Venezuelan). (3-15-22)
- 05. Equine Infectious Anemia. (3-15-22)
- 06. Equine Piroplasmosis (*Babesiosis*). (3-15-22)
- 07. Equine Viral Arteritis. (3-15-22)
- 08. Glanders. (3-15-22)
- 09. Hendra Virus. (3-15-22)
- 10. Japanese Encephalitis. (3-15-22)
- 11. Surra (*Trypanosoma evansi*). (3-15-22)

306. FOREIGN ANIMAL AND REPORTABLE DISEASES: FISH DISEASES.

- 01. Asian Tapeworm of Carp. (3-15-22)
- 02. Oncorhynchus Masou Virus Disease. (3-15-22)
- 03. Spring Viremia of Carp. (3-15-22)
- 04. Viral Hemorrhagic Septicemia. (3-15-22)

307. FOREIGN ANIMAL AND REPORTABLE DISEASES: LAGOMORPH DISEASES.

Rabbit Hemorrhagic Disease is a reportable disease. (3-15-22)

308. FOREIGN ANIMAL AND REPORTABLE DISEASES: SHEEP AND GOAT DISEASES.

- 01. Contagious Caprine Pleuropneumonia. (3-15-22)
- 02. Nairobi Sheep Disease. (3-15-22)
- 03. Ovine Brucellosis (*B. melitensis*). (3-15-22)
- 04. Peste des Petits Ruminants. (3-15-22)
- 05. Scrapie. (3-15-22)
- 06. Sheep and Goat Pox. (3-15-22)

309. FOREIGN ANIMAL AND REPORTABLE DISEASES: SWINE DISEASES.

- 01. African Swine Fever. (3-15-22)
- 02. Classical Swine Fever (Hog Cholera). (3-15-22)

- 03. Enterovirus Encephalitis (Teschen Disease). (3-15-22)
- 04. Nipah Virus Encephalitis. (3-15-22)
- 05. Porcine Brucellosis (*B. suis*). (3-15-22)
- 06. Swine Vesicular Disease. (3-15-22)
- 310. -- 329. (RESERVED)
- 330. NOTIFIABLE DISEASES.
All veterinarians licensed to practice in Idaho shall report any notifiable diseases listed in Subchapter A to the Administrator. The Administrator may add a notifiable disease by issuing an administrative order explaining in writing the reasons for requiring the disease to be reported. (3-15-22)
- 331. NOTIFIABLE DISEASES: MIXED SPECIES DISEASES.
West Nile Virus is a notifiable disease. (3-15-22)
- 332. NOTIFIABLE DISEASES: AVIAN DISEASES.
 - 01. Avian Mycoplasmosis (*M. gallisepticum* and *M. synoviae*). (3-15-22)
 - 02. Fowl Typhoid (*Salmonella gallinarum*). (3-15-22)
 - 03. Pullorum Disease (*Salmonella pullorum*). (3-15-22)
- 333. NOTIFIABLE DISEASES: BOVINE DISEASES.
 - 01. Hemorrhagic Septicemia (*Pasteurella multocida*). (3-15-22)
 - 02. Malignant Catarrhal Fever (Sheep Associated). (3-15-22)
- 334. NOTIFIABLE DISEASES: EQUINE DISEASES.
 - 01. Equine Herpesvirus Myeloencephalopathy. (3-15-22)
 - 02. Equine Rhinopneumonitis. (3-15-22)
- 335. NOTIFIABLE DISEASES: FISH DISEASES.
 - 01. Epizootic Hematopoietic Necrosis. (3-15-22)
 - 02. Infectious Hematopoietic Necrosis. (3-15-22)
 - 03. Whirling Disease. (3-15-22)
- 336. NOTIFIABLE DISEASES: LAGOMORPH DISEASES.
Myxomatosis is a notifiable disease. (3-15-22)
- 337. NOTIFIABLE DISEASES: SHEEP AND GOAT DISEASES.
 - 01. Bluetongue. (3-15-22)
 - 02. Caprine Arthritis/Encephalitis (CAE). (3-15-22)
 - 03. Caseous Lymphadenitis. (3-15-22)

- 04. Contagious Agalactia (*Mycoplasma spp.*). (3-15-22)
- 05. Enzootic Abortion (*Chlamydia psittici*). (3-15-22)
- 06. Footrot. (3-15-22)
- 07. Haemonchus Contortus (drug-resistant). (3-15-22)
- 08. Johne's Disease. (3-15-22)
- 09. Maedi-Visna/Ovine Progressive Pneumonia (OPP). (3-15-22)
- 10. Ovine Epididymitis (*Brucella ovis*). (3-15-22)
- 11. Toxoplasma Gondii Abortion. (3-15-22)
- 12. Vibrionic Abortion (*Campylobacter fetus*). (3-15-22)
- 338. NOTIFIABLE DISEASES: SWINE DISEASES.
 - 01. Porcine Reproductive and Respiratory Syndrome (PRRS). (3-15-22)
 - 02. Transmissible Gastroenteritis. (3-15-22)
- 339. -- ~~359.~~ (RESERVED)
- 360. ~~ACTINOMYCOSIS (LUMP JAW).~~
 - ~~01. Selling Diseased Animal.~~ It is unlawful for any person to knowingly sell, offer for sale, or in any manner transfer ownership to another person any animal infected or affected with the disease known as actinomycosis or lump jaw if the disease shows well marked clinical symptoms, or is in the advanced stage, except for immediate slaughter, and then only in accordance with the meat inspection rules and regulations of the USDA. (3-15-22)
 - ~~02. Public Livestock Markets.~~ Animals showing well marked clinical symptoms or in the advanced stage of actinomycosis or lump jaw passing through public livestock markets shall be placed and sold only from quarantine pens. (3-15-22)
- ~~361.—399.~~ (RESERVED)
- 400. ~~GARBAGE FEEDING.~~

No person shall feed garbage to swine. (3-15-22)

 - ~~01. Household Wastes.~~ Private household wastes not removed from the premises where produced is not considered garbage. (3-15-22)
 - ~~02. Inspection and Investigation.~~ The Administrator is authorized to enter upon any private or public property for the purpose of inspecting and investigating conditions relating to the feeding of garbage to swine. (3-15-22)
- 401.0. PSEUDORABIES -- PROCEDURES FOR CONTROL AND ERADICATION.
 - ~~01. Laboratories.~~ Blood, serum, tissues, or other samples are to be tested only by state/federal approved laboratories. (3-15-22)
 - ~~02. Supervision.~~ State or federal veterinarians will supervise pseudorabies control and eradication

efforts. (3-15-22)

~~03. Quarantines. Any herd in which any livestock has been determined to be infected with pseudorabies by an official pseudorabies test or diagnosed by a veterinarian as having pseudorabies will be placed under official state quarantine for pseudorabies. (3-15-22)~~

~~01. Sale of Infected Animals. All swine on pseudorabies-infected premises shall be sold for slaughter under permit within fifteen (15) days of diagnosis. (3-15-22)()~~

~~b. Livestock, other than swine, on pseudorabies infected premises shall be confined to the premises for a period of ten (10) days after the swine herd is sold for slaughter. Livestock, other than swine can, under permit, be moved to a separate holding area and be released from quarantine after a period of ten (10) days, if no signs of pseudorabies occur in the animals. (3-15-22)~~

~~402. Pseudorabies Vaccine. No person shall import into Idaho, possess, use, keep, buy, sell, offer for sale, barter, exchange, give away, or otherwise dispose of any pseudorabies vaccine without written permission from the Administrator. (3-15-22)()~~

~~403. VACCINATED SWINE. No person shall import into Idaho any swine that have been vaccinated for Pseudorabies. (3-15-22)~~

~~404.—419. (RESERVED)~~

~~420. ERADICATION METHODS. USDA Program Standards apply to elimination of pseudorabies from a herd. (3-15-22)~~

~~421.—429. (RESERVED)~~

~~403. Identification of Infected and Exposed Swine. All seropositive and infected swine are to be individually identified by placing a reactor ear tag in the left ear of the animal and recording the tag number on all movement documents. Identification shall be accomplished within five (5) days of the date the animals were being reported as positive or infected. All exposed swine removed from the premises of origin are to be administered official identification in the right ear of the animal prior to removal. Individual identification may be waived for swine moving directly to slaughter, on a permit, in a sealed vehicle. (3-15-22)()~~

~~431. IDENTIFICATION OF EXPOSED SWINE. All exposed swine that are removed from the premises of origin shall be individually identified by placing a swine identification tag in the right ear of the animal. The identification number shall be recorded on movement documents. Individual identification may be waived for swine moving directly to slaughter, on a permit, in a sealed vehicle. (3-15-22)~~

~~432.—449. (RESERVED)~~

~~450. QUALIFIED PSEUDORABIES NEGATIVE HERDS. The qualifying method and development of a pseudorabies negative herd shall be accomplished in accordance with the USDA Program Standards for pseudorabies. (3-15-22)~~

~~451.—459. (RESERVED)~~

~~460. CLEANING AND DISINFECTION. All pens, wherein swine are held prior to or after their sale, shall be thoroughly cleaned and disinfected within seventy-two (72) hours following completion of the sale or before the next sale, whichever occurs first. (3-15-22)~~

~~4601. -- 503. (RESERVED)~~

SUBCHAPTER B – ANIMAL HEALTH EMERGENCIES

504. INCORPORATION BY REFERENCE.

The following documents are incorporated by reference and apply only to Subchapter B, Sections 510-591: 9 C.F.R. § 53.2, January 1, 2002, which can be viewed online at <https://www.govinfo.gov/content/pkg/CFR-2002-title9-vol1/pdf/CFR-2002-title9-vol1-sec53-2.pdf>. (3-15-22)

5054. – 509. (RESERVED)

510. DEFINITIONS.

The definitions in Section 510 following apply in the interpretation and enforcement of Subchapter: B only: (3-15-22)()

- 01. Animals.** All vertebrates, except humans. (3-15-22)
- 02. Animal Health Emergency.** The discovery of any disease that could have a devastating impact on livestock, other animals, or people of this state, that requires immediately implementation of prevention, management, control, or eradication measures. ()
- 023. Conveyance.** Any type of vehicle, carrier, kennel, or trailer of any kind used to move or hold animals. (3-15-22)
- 034. Domestic Cervidae.** Elk, fallow deer, and reindeer owned by a person. (3-15-22)
- 045. Emergency Disease.** A disease, agent or parasite that could have a devastating impact on people, animals, or the economy as determined by the Director. (3-15-22)
- 056. Epidemiology.** The study of the distribution and determinants of health-related states or events in specified populations, and the application of this study to control of health problems. (3-15-22)
- 067. Exposed.** Animals that have had contact with other animals, herds, or materials that have been determined to be infected with or affected by any infectious, contagious, or communicable disease. (3-15-22)
- 078. Federal Animal Health Official.** An employee of USDA/APHIS/VS who is authorized to perform animal health activities. (3-15-22)
- 089. Foreign Animal Disease.** A transmissible disease of animals, believed to not exist in the United States and its territories, as determined by USDA that has a potential significant health or economic impact. (3-15-22)
- 109. Infected Zone.** The geographic portion of a quarantine area, which contains all animals known to be infected with or exposed to an emergency disease as designated by the Administrator. (3-15-22)
- 101. Livestock.** Cattle, swine, horses, mules, asses, sheep, goats, domestic cervidae, camelids, and ratites. (3-15-22)
- 142. Operator.** The person who has authority to manage or direct an animal premises or conveyance and the animals thereon. (3-15-22)
- 123. Premises.** The ground area, buildings, corrals, and equipment utilized to keep, hold or maintain animals. (3-15-22)
- 134. Quarantine.** A written order, executed by the Administrator, to confine or hold animals on a premises or any other location, where found, and prevent movement of animals from a premises or any other location when the Administrator has determined that the animals are infected with or exposed to a disease, or are not in compliance with the provisions of this chapter. (3-15-22)
- 145. Quarantine Area.** A geographic designation encompassing one (1) or more premises in one (1) or more counties, and consisting of an infected zone and a surveillance zone as determined by the Administrator.

(3-15-22)

156. State Animal Health Official. The Administrator, or his designee, who is responsible for disease control and eradication programs. (3-15-22)

167. Surveillance Zone. The geographic portion of the quarantine area surrounding the infected zone as designated by the Administrator. (3-15-22)

511. -- 5201. (RESERVED)

~~521. CIRCUMSTANCES OF AN ANIMAL HEALTH EMERGENCY.~~

~~The discovery of any emergency disease, which could have a devastating impact on the livestock, other animals, or people of this state, may constitute an animal health emergency requiring the implementation of prevention, management, control or eradication measures by state animal health officials. (3-15-22)~~

522. DECLARATION OF AN ANIMAL HEALTH EMERGENCY.

The Director is authorized to declare an animal health emergency upon the discovery of: (3-15-22)()

01. Foreign Animal Disease. ~~The discovery of any disease, parasite or agent which has been identified by the USDA/APHIS/VS as a “communicable foreign disease not known to exist in the United States”;~~ ~~or;~~ (3-15-22)()

02. Eradicated Diseases. ~~The discovery of any disease, parasite or agent which is not naturally occurring in or has been eradicated from Idaho, as determined by the Administrator, and which, if introduced into Idaho, would have a devastating impact on the livestock or other animals of the state; or~~ (3-15-22)()

03. Specific Diseases. ~~The exposure to or infection of foot and mouth disease, bovine spongiform encephalopathy, chronic wasting disease, other transmissible spongiform encephalopathies, brucellosis, tuberculosis, or any foreign, exotic or emerging disease, as determined by the Administrator. (3-15-22)~~

04. Disease Presence. ~~The presence of any foreign, eradicated, or specific diseases in any state in the United States, any country contiguous to the United States, or any country from which the state of Idaho receives animals or animal products may constitute an emergency. (3-15-22)~~

~~523. QUARANTINE AUTHORITY.~~

~~State or federal animal health officials are authorized to quarantine any animal infected with or exposed to an emergency disease, or any premises, county or area of the state to prevent ingress or egress of animals, people, or vehicles in the event of an emergency disease. (3-15-22)~~

5243. UTILIZATION OF VACCINATION IN ANIMAL HEALTH EMERGENCIES.

The Administrator is authorized to order the strategic use of vaccinations, treatments or other remedies to reduce the risk or spread of emergency diseases. (3-15-22)

5254. -- 52931. (RESERVED)

~~530. QUARANTINE PROCEDURES FOR AN ANIMAL HEALTH EMERGENCY.~~

~~State or federal animal health officials are authorized to place under quarantine any infected animals, exposed animals, and those animals exhibiting signs of an emergency disease. The quarantine may also include susceptible animals not yet exposed. (3-15-22)~~

01. Written Notice. ~~Written notice of quarantine will be given to the owner of the animals, or the owner or operator of the premises or conveyance where the animals are found. (3-15-22)~~

02. Validity of Quarantine. ~~The quarantine is valid whether or not it is acknowledged by signature of the owner or operator. (3-15-22)~~

03. Quarantine Release. ~~The quarantine remains in place until a state or federal animal health official~~

~~releases the quarantine in writing. (3-15-22)~~

~~**531. QUARANTINE AREA.**~~

~~The Administrator may establish a quarantine area, which includes an infected zone encompassing the infected and exposed animals and premises, and a surveillance zone, based on the locations of said premises and the characteristics and epidemiology of the disease. The quarantine area may include one or more premises, all or part of a county, or all or part of the state. (3-15-22)~~

532. QUARANTINE AREA SECURITY.

The Administrator may limit access of people and vehicles to the quarantine area. (3-15-22)

533. QUARANTINE AREA BIO-SECURITY.

Bio-security of the quarantine area will be instituted and maintained. (3-15-22)

01. Personnel. People entering or leaving the quarantine area will follow disinfection or decontamination guidelines and procedures established by state or federal animal health officials. (3-15-22)

02. Vehicles and Equipment. Vehicles and equipment moving into or out of the quarantine area will be cleaned and disinfected or decontaminated according to guidelines and procedures established by state or federal animal health officials. (3-15-22)

~~**534. ANIMAL MOVEMENT IN QUARANTINE AREA.**~~

~~Animals shall not be moved into, out of, through, or within the quarantine area except by permit issued by the Administrator. (3-15-22)~~

~~**535. SALE OF DISEASED OR EXPOSED ANIMALS NOT ALLOWED.**~~

~~Animals infected with, or susceptible animals exposed to, an emergency disease shall not be set free, sold, or in any way transferred to another person without written authorization from the Administrator. (3-15-22)~~

~~**5364. EXPOSURE OF ANOTHER'S ANIMALS NOT ALLOWED.**~~

~~Animals infected with or exposed to an emergency disease or any disease not known to exist in Idaho shall not be: (3-15-22)~~

~~**01. Housed.** Housed with, or adjacent to, another person's animals that have not been previously exposed or land used for raising such animals; or (3-15-22)~~

~~**02. Turned Out.** Turned out with, or adjacent to, another person's animals that have not been previously exposed or land used for raising such animals. (3-15-22)~~

~~**5375. MOVEMENT OR SALE OF ANIMAL PRODUCTS.**~~

~~The Administrator may prohibit the movement or sale of products from animals infected with or exposed to an emergency disease. (3-15-22)~~

~~**5386. -- 53940. (RESERVED)**~~

~~**540. RESTRICTIONS ON ANIMALS FROM AREAS OR STATES AFFECTED BY EMERGENCY DISEASES.**~~

~~The Administrator may impose restrictions on animal movement into Idaho from areas or states affected by an emergency disease as provided in IDAPA 02.04.21, "Rules Governing the Importation of Animals." (3-15-22)~~

~~**541. ANIMALS IN TRANSIT AT TIME OF DECLARED EMERGENCY.**~~

~~The Administrator will determine the disposition of animals in transit at the time of the declaration of an animal health emergency. (3-15-22)~~

~~**542. -- 549. (RESERVED)**~~

~~**550. CONDEMNATION OF INFECTED, EXPOSED, OR SUSCEPTIBLE ANIMALS.**~~

~~The Administrator is authorized to condemn, and order the slaughter, destruction, or other disposition of animals, infected with, exposed to, or susceptible to an emergency disease. (3-15-22)~~

~~551.—559. (RESERVED)~~

~~**560. DEPOPULATION OF ANIMALS.**~~

~~Animals infected with, exposed to, or susceptible to an emergency disease may be depopulated to control and eradicate the disease. (3-15-22)~~

~~**01. Preventive Slaughter or Destruction.** Animals, located within the quarantine area, that are susceptible to an emergency disease may be depopulated to control or eradicate the emergency disease. (3-15-22)~~

~~**02. Scope of Depopulation.** The Administrator will determine the scope of depopulation. (3-15-22)~~

~~**561. METHOD OF DEPOPULATION.**~~

~~The Administrator will determine the method for destruction of animals in quarantine areas. (3-15-22)~~

~~**562. TIME LIMIT FOR DEPOPULATION.**~~

~~The Administrator will determine the time limit for depopulation of condemned animals. (3-15-22)~~

~~563.—569. (RESERVED)~~

570. COMPENSATION FOR APPRAISED ANIMALS.

Owners of condemned animals will be compensated for animals ordered destroyed by the Administrator if the animals are appraised prior to depopulation, and the owner is in compliance with these rules. Compensation may be paid on animals that die or are depopulated before appraisal at the discretion of the Administrator. (3-15-22)

571. COMPENSATION FOR ANIMALS DESTROYED.

State compensation is limited to appraised value less any federal indemnity and salvage value for animals condemned, and slaughtered or otherwise destroyed. (3-15-22)

572. APPRAISAL PROCEDURE FOR ANIMALS DEPOPULATED.

01. Animal Appraisal. Animals to be depopulated shall be appraised by a team of three (3) persons including: (3-15-22)

~~**a.** A representative of the Division of Animal Industries; (3-15-22)~~

ba. The owner; and (3-15-22)

eb. A person with experience marketing the species of animal as determined by the Administrator. (3-15-22)

02. Dispute of Appraisal. When the appraisal price is in dispute, the Director may grant a hearing to any person, under such rules as the Department may prescribe which are in compliance with Title 67, Chapter 52, Idaho Code. (3-15-22)

~~**573. TIME LIMIT FOR APPRAISAL.**~~

~~The Administrator will determine the time limit for completing the appraisal. (3-15-22)~~

~~574. -- 579. (RESERVED)~~

580. COMPENSATION FOR LABOR EMPLOYED.

01. Disposal of Animals. The Department may pay actual costs for labor employed for disposal of animals depopulated at the direction of the Administrator. (3-15-22)

02. Cleaning and Disinfection. The Department may pay actual costs for labor employed in the cleaning and disinfection of premises where infected or exposed animals were kept. (3-15-22)

581. COMPENSATION FOR PROPERTY DESTROYED.
The Department will compensate owners for property ordered destroyed by the Administrator. (3-15-22)

01. Property Destroyed Otherwise. The department may compensate owners for property otherwise destroyed as approved by the Administrator. (3-15-22)

02. Actual Value. The Department will pay actual value of property destroyed, as determined by the Administrator, if compensation is paid. (3-15-22)

582. -- 589. (RESERVED)

~~**590. CLEANING AND DISINFECTION OF PREMISES.**
Any premises or area where animals infected with or exposed to an emergency disease were held or kept shall be cleaned, disinfected, or decontaminated under the supervision and at the direction of state or federal animal health officials within the time limit established by the Administrator. (3-15-22)~~

~~**591. CLEANING AND DISINFECTION OF ANIMAL CONVEYANCE.**
Any conveyance used to hold or transport animals infected with or exposed to an emergency disease shall be cleaned, disinfected, or decontaminated under the supervision and at the direction of state or federal animal health officials within the time limit established by the Administrator. (3-15-22)~~

~~**592.—999. (RESERVED)**~~

IDAPA 02 – IDAHO STATE DEPARTMENT OF AGRICULTURE
02.04.05 – RULES GOVERNING GRADE A MILK AND MANUFACTURE GRADE MILK
DOCKET NO. 02-0405-2401
NOTICE OF RULEMAKING – PROPOSED RULE

AUTHORITY: In compliance with Section 67-5221(1), Idaho Code, notice is hereby given that this agency has initiated proposed rulemaking procedures. The action is authorized pursuant to Sections 37-303, 37-402, 37-405, AND 37-516, Idaho Code.

PUBLIC HEARING SCHEDULE: Public hearing(s) concerning this rulemaking will be scheduled if requested in writing by twenty-five (25) persons, a political subdivision, or an agency, not later than October 16, 2024.

The hearing site(s) will be accessible to persons with disabilities. Requests for accommodation must be made not later than five (5) days prior to the hearing, to the agency address below.

DESCRIPTIVE SUMMARY: The following is a nontechnical explanation of the substance and purpose of the proposed rulemaking:

The proposed rule updates changes in federal code regarding pasteurized milk ordinances, methods of making sanitation rating milk shippers, evaluation of milk laboratories, and procedures governing the cooperative state-public health service/Food and Drug Administration Program of the National Conference on Interstate Milk Shippers. This rule governs procedures for the design, construction, production, manufacture, distribution, handling, storage, quality, analysis and sale of Grade A Milk and Manufacture Grade Milk and Milk Products to ensure safe and wholesome dairy products.

FEE SUMMARY: The following is a specific description of the fee or charge imposed or increased:

There is no change in fee or charge

FISCAL IMPACT: The following is a specific description, if applicable, of any negative fiscal impact on the state General Fund greater than ten thousand dollars (\$10,000) during the fiscal year resulting from this rulemaking:

There is no fiscal impact on the state General Fund greater than ten thousand dollars (\$10,000).

NEGOTIATED RULEMAKING: Pursuant to Section 67-5220(2), Idaho Code, negotiated rulemaking was not conducted because these changes are to the publication dates of documents that were already incorporated into these rules.

INCORPORATION BY REFERENCE: Pursuant to Section 67-5229(2)(a), Idaho Code, the following is a brief synopsis of why the materials cited are being incorporated by reference into this rule:

PMO- Pasteurized Milk Ordinances:

The standards for continuous water disinfection using Ultraviolet (UV) treatment have been relaxed, particularly for water used in dairy production.

New labeling requirements have been introduced for homeopathic drugs, which previously did not have any labeling guidelines.

The PMO has removed the requirements for lighting and ventilation in Automated Milking Installations (AMIs). Previously, AMIs were required to have positive air ventilation systems in operation during the cleaning or sanitizing of the milking system.

MMSR- Methods of Making Sanitation Rating Milk Shippers:

Ratings are now due by the last day of the month; prior ratings were due exactly on the anniversary date from the last rating.

A proposal eliminates the evaluation of the Milking Time Inspection program for dairy farms from the calculations of enforcement ratings under Part I. Prior version required an Inspection of a producer while milking and not milking.

A proposal included additional pertinent animal health information to be updated within the MMSR. This information included the specific testing requirements and current language within Section 8 of the PMO with regards to Tuberculosis and Brucellosis testing for animals intended for Grade “A” milk production.

EML-Evaluation of Milk Laboratories:

No Proposals were passed that addressed changes to the Evaluation of Milk Laboratories (EML). Procedures Governing the Cooperative State-Public Health Service/ Food and Drug Administration Program of the National Conference on Interstate Milk Shipments

A proposal formalizes the NCIMS Aseptic Program Committee (APC) as a standing committee in accordance with the NCIMS Constitution and Bylaws

IDAHO CODE SECTION 22-101A STATEMENT: Pursuant to 22-101A(1), for any rule promulgated or adopted by the director which is broader in scope or more stringent than federal law or regulations, or which regulates an activity not regulated by the federal government, the director shall identify the portions of the adopted rule that are broader in scope or more stringent than federal law or rules, or which regulate an activity not regulated by the federal government. The following sections of the rule are broader in scope, more stringent than federal law or regulations, or regulate an activity not regulated by the federal government:

The federal government does regulate Grade A Milk and Manufacture Grade Milk. Idaho Code mimics federal regulation to ensure compliance with federal law. This activity is defined in Idaho Code.

The detailed 22-101A analysis can be found on the agency’s website at www.agri.idaho.gov.

ASSISTANCE ON TECHNICAL QUESTIONS, SUBMISSION OF WRITTEN COMMENTS: For assistance on technical questions concerning the proposed rule, contact Lloyd Knight at lloyd.knight@isda.idaho.gov.

Anyone may submit written comments regarding this proposed rulemaking. All written comments must be directed to the undersigned and must be delivered on or before October 23, 2024.

DATED this 2nd day of October, 2024.

Lloyd Knight
Deputy Director
Idaho Department of Agriculture
2270 Old Penitentiary Road
P.O. Box 7249
Boise, Idaho 83707
Phone: (208) 332-8615
Email: lloyd.knight@isda.idaho.gov

THE FOLLOWING IS THE PROPOSED TEXT OF DOCKET NO. 02-0405-2401
(Only Those Sections With Amendments Are Shown.)

02.04.05 – RULES GOVERNING GRADE A MILK AND MANUFACTURE GRADE MILK

104. INCORPORATION BY REFERENCE.

All Grade A Milk and Milk Products shall comply with the provisions set forth in the following documents incorporated by reference in this Subchapter A only: (3-15-22)

01. Grade “A” Pasteurized Milk Ordinance. The Grade “A” Pasteurized Milk Ordinance, 2019~~23~~ revision, published by the U. S. Department of Health and Human Services, Public Health Service, Food and Drug Administration, except the bacterial limit standard and the somatic cell count standard in Section 7 of the document. Available online at ~~https://www.fda.gov/media/140394/download~~ <https://www.fda.gov/media/180975/download?attachment>. (3-15-22)()

02. Evaluation of Milk Laboratories. The Evaluation of Milk Laboratories, 2019~~23~~ revision, published by the U. S. Department of Health and Human Services, Public Health Service, Food and Drug Administration. Available online at ~~https://www.fda.gov/media/137754/download~~ <https://www.fda.gov/media/180977/download?attachment>. (3-15-22)()

03. Methods of Making Sanitation Ratings of Milk Shippers, and the Certifications/Listings of Single-Service Containers and/or Closures for Milk and/or Milk Products Manufactures. The Methods of Making Sanitation Ratings of Milk Shippers, and the Certifications/Listings of Single-Service Containers and/or Closures for Milk and/or Milk Products Manufactures, 2019~~23~~ revision, published by the U. S. Department of Health and Human Services, Public Health Service, Food and Drug Administration. Available online at ~~https://www.fda.gov/media/138393/download~~ <https://www.fda.gov/media/180976/download?attachment>. (3-15-22)()

04. Interstate Milk Shipments. The Procedures Governing the Cooperative State-Public Health Service/Food and Drug Administration Program of the National Conference on Interstate Milk Shipments, 2019~~23~~ revision, published by the U. S. Department of Health and Human Services, Public Health Service, Food and Drug Administration, and the National Conference on Interstate Milk Shipments. Available online at ~~https://www.fda.gov/media/138115/download~~ <https://www.fda.gov/media/180974/download?attachment>. (3-15-22)()

IDAPA 02 – IDAHO STATE DEPARTMENT OF AGRICULTURE
02.04.15 – RULES GOVERNING BEEF CATTLE ANIMAL FEEDING OPERATIONS
DOCKET NO. 02-0415-2401
NOTICE OF RULEMAKING – PROPOSED RULE

AUTHORITY: In compliance with Section 67-5221(1), Idaho Code, notice is hereby given that this agency has initiated proposed rulemaking procedures. The action is authorized pursuant to Sections 22-110 and 22-4903, Idaho Code.

PUBLIC HEARING SCHEDULE: Public hearing(s) concerning this rulemaking will be scheduled if requested in writing by twenty-five (25) persons, a political subdivision, or an agency, not later than October 16, 2024.

The hearing site(s) will be accessible to persons with disabilities. Requests for accommodation must be made not later than five (5) days prior to the hearing, to the agency address below.

DESCRIPTIVE SUMMARY: The following is a nontechnical explanation of the substance and purpose of the proposed rulemaking:

This rulemaking is being facilitated to remove now redundant language that is included in the Environmental & Nutrient Management Rule that underwent Zero Based Regulation (ZBR) review in 2023 and was approved by the Idaho Legislature in 2024. This rule was last open for ZBR review in 2022.

The rule was reviewed over the course of one negotiated rulemaking meeting, and that review benefited from the participation of program stakeholders. No negative comments were submitted as part of this rulemaking process.

FEE SUMMARY: The following is a specific description of the fee or charge imposed or increased:

There is no change in fee or charge

FISCAL IMPACT: The following is a specific description, if applicable, of any negative fiscal impact on the state General Fund greater than ten thousand dollars (\$10,000) during the fiscal year resulting from this rulemaking:

There is no fiscal impact on the state General Fund greater than ten thousand dollars (\$10,000).

NEGOTIATED RULEMAKING: Pursuant to Section 67-5220(1), Idaho Code, negotiated rulemaking was conducted. The Notice of Intent to Promulgate Rules - Negotiated Rulemaking was published in the July 3, 2024 Idaho Administrative Bulletin, [Volume 24-7, Pages 43 and 44](#).

INCORPORATION BY REFERENCE: Pursuant to Section 67-5229(2)(a), Idaho Code, the following is a brief synopsis of why the materials cited are being incorporated by reference into this rule:

The 1997 United States Department of Agriculture Natural Resources Conservation Service Agricultural Waste Management Field Handbook was added as an attachment to the ISDA website. The referenced web address change reflected this.

The 1999 Publication by the United States Department of Agriculture, Natural Resource Conservation Service, Conservation Practice Standard, Nutrient Management Code 590 was removed to be consistent with rule changes approved by the Idaho Legislature in the 2024 session.

IDAHO CODE SECTION 22-101A STATEMENT: Pursuant to 22-101A(1), for any rule promulgated or adopted by the director which is broader in scope or more stringent than federal law or regulations, or which regulates an activity not regulated by the federal government, the director shall identify the portions of the adopted rule that are broader in scope or more stringent than federal law or rules, or which regulate an activity not regulated by the federal government. The following sections of the rule are broader in scope, more stringent than federal law or regulations, or regulate an activity not regulated by the federal government:

This rule implements the requirements of the Beef Cattle Environmental Control Act, as defined in Title 22, Chapter 49, Idaho Code. The federal government does have regulatory authority over the permitting of discharges from beef cattle animal feeding operations, which is implemented by the Idaho Department of Environmental Quality Idaho Pollution Discharge Elimination System (IPDES) program.

The detailed 22-101A analysis can be found on the agency's website at www.agri.idaho.gov.

ASSISTANCE ON TECHNICAL QUESTIONS, SUBMISSION OF WRITTEN COMMENTS: For assistance on technical questions concerning the proposed rule, contact Lloyd Knight at lloyd.knight@isda.idaho.gov.

Anyone may submit written comments regarding this proposed rulemaking. All written comments must be directed to the undersigned and must be delivered on or before October 23, 2024.

DATED this 2nd day of October, 2024.

Lloyd Knight
Deputy Director
Idaho Department of Agriculture
2270 Old Penitentiary Road
P.O. Box 7249
Boise, Idaho 83707
Phone: (208) 332-8615
Email: lloyd.knight@isda.idaho.gov

THE FOLLOWING IS THE PROPOSED TEXT OF DOCKET NO. 02-0415-2401
(Only Those Sections With Amendments Are Shown.)

02.04.15 – RULES GOVERNING BEEF CATTLE ANIMAL FEEDING OPERATIONS

001. SCOPE.

These rules govern the design, function, and management practices of waste systems on beef cattle animal feeding operations. ~~Nothing in this rule affects the authority of the Department of Environmental Quality to enforce an IPDES permit for dairy farms that discharge pollutants to waters of the United States, including without limitation, the authority to issue permits, access records, conduct inspections and take enforcement actions. The provisions of this rule do not alter the requirements, liabilities, and authorities with respect to or established by the IPDES program.~~ (4-6-23)()

002. INCORPORATION BY REFERENCE.

The following documents are incorporated by reference into this chapter: (4-6-23)

01. The 1997 United States Department of Agriculture Natural Resources Conservation Service Agricultural Waste Management Field Handbook, Appendix 10 D. This document can be viewed online at ~~http://directives.sc.egov.usda.gov/OpenNonWebContent.aspx?content=17767.wba~~ https://agri.idaho.gov/main/wp-content/uploads/2017/08/nrcs_10d_1997.pdf. (4-6-23)()

02. Society of Agricultural and Biological Engineers Specification ASAE EP393.3 Manure Storages February 2004. This document is part of a copyrighted publication and is available for viewing at the ISDA offices or a copy may be purchased online at <http://www.asabe.org/>. (4-6-23)

~~03. The 1999 Publication by the United States Department of Agriculture, Natural Resource Conservation Service, Conservation Practice Standard, Nutrient Management Code 590. This can be viewed online at https://agri.idaho.gov/main/wp-content/uploads/2017/08/nutrient_Management_code_590.pdf. (4-6-23)~~

043. The Phosphorus Site Index: A Systematic Approach to Assess the Risk of Nonpoint Source Pollution of Idaho Waters by Agricultural Phosphorus, 2022. This document is available online at <https://agri.idaho.gov/main/wp-content/uploads/2022/03/PSIBeef.pdf>. (4-6-23)

003. DEFINITIONS.

The following definitions apply in the interpretation and enforcement of this chapter. (4-6-23)

01. Animal. Bovidae, ovidae, suidae, equidae, captive cervidae, captive antilocapridae, camelidae, and ratitidae. (4-6-23)

02. Animal Feeding Operation. A lot or facility where slaughter and feeder cattle or dairy heifers are confined and fed for a total of forty-five (45) days or more during any twelve-month (12) period and crops, vegetation forage growth, or post-harvest residues are not sustained in the normal growing season over any portion of the lot or facility. (4-6-23)()

03. Compost. A biologically stable material derived from the biological decomposition of organic matter. (4-6-23)

04. Concentrated Animal Feeding Operation. An AFO that is defined as a large CAFO or as a medium CAFO by the terms of this section and designated by the Director. Two (2) or more AFOs under common ownership on contiguous property are considered to be a single AFO for the purposes of determining the number of animals at an operation, if they adjoin each other, or if they use a common area or system for the disposal of wastes. (4-6-23)

05. Discharge. Release of process wastewater or manure from a beef cattle animal feeding operation to waters of the state. (4-6-23)

~~06. Idaho Pollutant Discharge Elimination System (IPDES). Idaho's program for issuing, modifying, revoking and reissuing, terminating, monitoring and enforcing permits, and imposing and enforcing pretreatment requirements, under these rules and the Clean Water Act sections 307, 402, 318, and 405. (4-6-23)~~

~~076.~~ **Land Application.** The spreading on, or incorporation of manure or process wastewater into the soil. (4-6-23)

087. **Large Concentrated Animal Feeding Operation.** An AFO is defined as a large CAFO if it stables or confines as many as or more than the numbers of cattle specified in any of the following categories: (4-6-23)

a. Seven hundred (700) mature dairy cows, whether milked or dry; (4-6-23)

b. One thousand (1,000) veal calves; (4-6-23)

c. One thousand (1,000) cattle other than mature dairy cows or veal calves. Cattle includes but is not limited to heifers, steers, bulls and cow/calf pairs; (4-6-23)

~~098.~~ **Medium Concentrated Animal Feeding Operation.** A medium CAFO includes any AFO that has been defined or designated as CAFO and stables or confines the number of cattle that fall within any of the following ranges: (4-6-23)

a. Two hundred (200) to six hundred ninety-nine (699) mature dairy cows, whether milked or dry; (4-6-23)

b. Three hundred (300) to nine hundred ninety-nine (999) veal calves; (4-6-23)

c. Three hundred (300) to nine hundred ninety-nine (999) cattle other than mature dairy cows or veal calves. Cattle includes but is not limited to heifers, steers, bulls and cow/calf pairs; (4-6-23)

~~109.~~ **Operate.** Confining and feeding slaughter and feeder cattle in the state of Idaho. (4-6-23)

~~110.~~ **Operator.** The person who has power or authority to manage, or direct, or has financial control of a beef cattle animal feeding operation. (4-6-23)

~~121.~~ **Phosphorus Site Index.** A method to evaluate the relative potential for off-site movement of phosphorus from a field or pasture based upon risk factors relating to surface transport, phosphorus loss potential and nutrient management practices. (4-6-23)

~~132.~~ **Runoff.** Any precipitation that comes into contact with manure, compost, bedding, or feed on a beef cattle animal feeding operation. (4-6-23)

~~143.~~ **Slaughter and Feeder Cattle.** All cattle except those cattle located on a dairy farm permitted by the Idaho State Department of Agriculture pursuant to IDAPA 02.04.14, "Rules Governing Dairy Byproduct." (4-6-23)

~~154.~~ **Small Concentrated Animal Feeding Operation.** An AFO that is designated as a CAFO and is not a medium or large CAFO. (4-6-23)

004. ABBREVIATIONS.

~~01.~~ **AFO.** Animal Feeding Operation. (4-6-23)

~~02.~~ **CAFO.** Concentrated Animal Feeding Operation. (4-6-23)

~~03.~~ ~~IPDES. Idaho Pollutant Discharge Elimination System.~~ (4-6-23)

~~043.~~ **NMP.** Nutrient Management Plan. (4-6-23)

~~054.~~ **NRCS.** United States Department of Agriculture, Natural Resources Conservation Service. (4-6-23)

~~065.~~ **PSI.** Phosphorus Site Index (4-6-23)

(BREAK IN CONTINUITY OF SECTIONS)

020. WASTEWATER STORAGE AND CONTAINMENT FACILITIES.

~~01.~~ **Wastewater Storage and Containment Facilities.** All beef cattle AFOs where process wastewater leaves the confinement area and has the potential to impact surface water or be in violation of state water quality standards shall have wastewater storage and containment facilities designed, constructed, and operated, ~~and maintained sufficient to contain;~~ to meet a minimum of one hundred twenty (120) days of holding capacity and pursuant to IDAPA 02.04.30, Rules Governing Environmental and Nutrient Management. (4-6-23)()

~~a.~~ ~~All process wastewater generated on the facility during the non-land application season; and~~ (4-6-23)

~~b.~~ ~~The runoff from a twenty-five (25) year, twenty-four (24) hour rainfall event; and~~ (4-6-23)

~~c.~~ ~~Either three (3) inches of runoff from the accumulation of winter precipitation or the amount of runoff from the accumulation of precipitation from a one-in-five (1 in 5) year winter.~~ (4-6-23)

02. All Substances Entering Wastewater Storage and Containment Facilities. All substances entering wastewater storage and containment facilities shall be composed of manure and process wastewater from the operation of the beef cattle AFO. The disposal of any other materials into a wastewater storage and containment facility, including, but not limited to, human waste, is prohibited. (4-6-23)

(BREAK IN CONTINUITY OF SECTIONS)

~~032. NUTRIENT MANAGEMENT RECORDS.~~

~~The operators of beef cattle AFOs shall keep complete and accurate records of: (4-6-23)~~

~~**01. Land Application.** The dates and amounts of any manure or process wastewater applied on land owned or controlled by the operator. (4-6-23)~~

~~**02. Manure Transferred to Another Person.** The name and address of any third party that receives manure or process wastewater from the operation, including the dates of the transfer and the amount of manure or process wastewater transferred. (4-6-23)~~

~~032. -- 039. (RESERVED)~~

(BREAK IN CONTINUITY OF SECTIONS)

~~041. -- 049. (RESERVED)~~

~~050. ADMINISTRATION OF IPDES PROGRAM.~~

~~The Director of the Department of Agriculture and the Director of the Department of Environmental Quality shall, as appropriate, establish an agreement relating to the administration of an IPDES program that recognizes the expertise of the Department of Agriculture. (4-6-23)~~

~~051. COMPLIANCE WITH IDAHO POLLUTANT DISCHARGE ELIMINATION SYSTEM RULES.~~

~~The Department of Environmental Quality shall be solely responsible and authorized to determine whether the discharge of pollutants from a beef cattle feeding operation is required to be authorized by an IPDES permit. The provisions of this rule do not define when a beef cattle feeding operations is required to obtain a permit for a discharge, do not exempt a beef cattle feeding operation from permitting requirements for such discharges or alter the authority of DEQ with respect to such discharges. (4-6-23)~~

~~052. -- 999. (RESERVED)~~

IDAPA 02 – IDAHO STATE DEPARTMENT OF AGRICULTURE

02.04.19 – RULES GOVERNING DOMESTIC CERVIDAE

DOCKET NO. 02-0419-2401

NOTICE OF RULEMAKING – PROPOSED RULE

AUTHORITY: In compliance with Section 67-5221(1), Idaho Code, notice is hereby given that this agency has initiated proposed rulemaking procedures. The action is authorized pursuant to Sections 25-3704, 25-303, 25-305, 25-401, 25-601, Idaho Code.

PUBLIC HEARING SCHEDULE: Public hearing(s) concerning this rulemaking will be scheduled if requested in writing by twenty-five (25) persons, a political subdivision, or an agency, not later than October 16, 2024.

The hearing site(s) will be accessible to persons with disabilities. Requests for accommodation must be made not later than five (5) days prior to the hearing, to the agency address below.

DESCRIPTIVE SUMMARY: The following is a nontechnical explanation of the substance and purpose of the proposed rulemaking:

H 591 was passed by the Idaho Legislature and approved by the Governor during the 2024 Legislative Session. The legislation made certain changes to the quarantine process, sampling protocols, and requirements for domestic cervidae operations while under quarantine. This rulemaking will make the rule consistent and compliant with the legislation.

FEE SUMMARY: The following is a specific description of the fee or charge imposed or increased:

There is no change in fee or charge.

FISCAL IMPACT: The following is a specific description, if applicable, of any negative fiscal impact on the state General Fund greater than ten thousand dollars (\$10,000) during the fiscal year resulting from this rulemaking:

There is no fiscal impact on the state General Fund greater than ten thousand dollars (\$10,000).

NEGOTIATED RULEMAKING: Pursuant to Section 67-5220(1), Idaho Code, negotiated rulemaking was conducted. The Notice of Intent to Promulgate Rules - Negotiated Rulemaking was published in the July 3, 2024 Idaho Administrative Bulletin, [Volume 24-7, Pages 45 and 46](#).

INCORPORATION BY REFERENCE: Pursuant to Section 67-5229(2)(a), Idaho Code, the following is a brief synopsis of why the materials cited are being incorporated by reference into this rule:

There are no changes to documents already incorporated by reference.

IDAHO CODE SECTION 22-101A STATEMENT: Pursuant to 22-101A(1), for any rule promulgated or adopted by the director which is broader in scope or more stringent than federal law or regulations, or which regulates an activity not regulated by the federal government, the director shall identify the portions of the adopted rule that are broader in scope or more stringent than federal law or rules, or which regulate an activity not regulated by the federal government. The following sections of the rule are broader in scope, more stringent than federal law or regulations, or regulate an activity not regulated by the federal government:

The purpose of the rule is to implement the requirements of Title 25, Chapter 37, Idaho Code. The federal government does not regulate cervidae within the state, with the exception of certain requirements for import into the United States.

The detailed 22-101A analysis can be found on the agency's website at www.agri.idaho.gov.

ASSISTANCE ON TECHNICAL QUESTIONS, SUBMISSION OF WRITTEN COMMENTS: For assistance on technical questions concerning the proposed rule, contact Lloyd Knight at lloyd.knight@isda.idaho.gov.

Anyone may submit written comments regarding this proposed rulemaking. All written comments must be directed to the undersigned and must be delivered on or before October 23, 2024.

DATED this 2nd day of October, 2024.

Lloyd Knight
Deputy Director
Idaho Department of Agriculture
2270 Old Penitentiary Road
P.O. Box 7249
Boise, Idaho 83707
Phone: (208) 332-8615
Email: lloyd.knight@isda.idaho.gov.

THE FOLLOWING IS THE PROPOSED TEXT OF DOCKET NO. 02-0419-2401
(Only Those Sections With Amendments Are Shown.)

02.04.19 – RULES GOVERNING DOMESTIC CERVIDAE

010. DEFINITIONS.

01. Approved Laboratory. NVSL, an AAFLD accredited laboratory that is qualified to perform CWD diagnostic procedures, or a laboratory designated by the Administrator to perform CWD diagnostic procedures. (3-15-22)

02. Approved Slaughter Establishment. A USDA inspected slaughter establishment at which ante-mortem and post-mortem inspection is conducted by USDA inspectors. (3-15-22)

03. Area Veterinarian in Charge. The USDA/APHIS/VS veterinary official who is assigned to supervise and perform official animal health activities in Idaho. (3-15-22)

04. Breed Associations and Registries. Organizations maintaining permanent records of ancestry or pedigrees of animals, individual animal identification records and records of ownership. (3-15-22)

05. Cervid Herd. One (1) or more domestic cervidae or groups of domestic cervidae maintained on common ground or under common ownership or supervision that may be geographically separated but can have interchange or movement. (3-15-22)

06. Cervidae. Deer, elk, moose, caribou, reindeer, and related species and hybrids including all members of the cervidae family and hybrids. (3-15-22)

07. Chronic Wasting Disease (CWD). A transmissible spongiform encephalopathy of cervids that is a nonfebrile, transmissible, insidious, and degenerative disease affecting the central nervous system of cervidae. (3-15-22)()

~~**08. Commingling.** Within the last five (5) years, the animals have had direct contact with each other, had less than thirty (30) feet of physical separation, or shared management equipment, pasture, or surface water sources, except for periods of less than forty eight (48) hours at sales or auctions when a state or federal animal health official has determined such contact presents minimal risk of CWD transmission. (3-15-22)~~

~~098.~~ **Custom Exempt Slaughter Establishment.** A slaughter establishment that is subject to facility inspection by USDA, but that does not have ante-mortem and post-mortem inspection of animals by USDA inspectors. (3-15-22)

~~109.~~ **CWD-Adjacent Herd.** A herd of domestic cervidae occupying premises that border a premises occupied by a CWD positive herd, including herds separated by roads or streams. (3-15-22)

~~11.~~ **CWD-Exposed Animal.** A cervid animal that is not exhibiting any signs of CWD, but has had contact within the last five (5) years with cervids from a CWD positive herd or the animal is a member of a CWD-exposed herd. (3-15-22)

~~12.~~ **CWD-Exposed Herd.** A herd of cervidae in which no animals are exhibiting signs of CWD, but: (3-15-22)

~~a.~~ An epidemiological investigation indicates that contact with CWD positive animals or contact with animals from a CWD positive herd has occurred in the previous five (5) years; or (3-15-22)

~~b.~~ A herd of cervidae occupying premises that were previously occupied by a CWD positive herd within the past five (5) years as determined by the designated epidemiologist; or (3-15-22)

~~c.~~ Two (2) herds that are maintained on a single premises even if they are managed separately, have no commingling, and have separate herd records. (3-15-22)

~~13.~~ **CWD-Positive Cervid.** A domestic cervid on which a diagnosis of CWD has been confirmed through positive test results on any official cervid CWD test by an approved laboratory. (3-15-22)

~~14.~~ **CWD-Positive Herd.** A domestic cervidae herd in which any animal(s) has been diagnosed with CWD, based on positive laboratory results, from an approved laboratory. (3-15-22)

~~15.~~ **CWD-Suspect Cervid.** A domestic cervid for which laboratory evidence or clinical signs suggests a diagnosis of CWD. (3-15-22)

~~160.~~ **CWD-Suspect Herd.** A domestic cervidae herd in which any animal(s) has been determined to be a CWD-suspect. (3-15-22)

~~171.~~ **Death Certificate.** A form, approved by the administrator, provided by the Division for the reporting of cervidae deaths and for reporting sample submission for CWD testing. (3-15-22)

~~182.~~ **Designated Epidemiologist.** A state or federal veterinarian who has demonstrated the knowledge and ability to perform the functions required under these rules and who has been selected by the Administrator to fulfill the epidemiology duties relative to the state domestic cervidae disease control program. (3-15-22)

~~193.~~ **Disposal.** Final disposition of dead cervidae. (3-15-22)

~~2014.~~ **Domestic Cervidae.** Fallow deer (*Dama dama*), elk (*Cervus elaphus*) or reindeer (*Rangifer tarandus*) owned by a person. (3-15-22)

~~2415.~~ **Domestic Cervidae Ranch.** A premises where domestic cervidae are held or kept, including multiple premises under common ownership. (3-15-22)

~~2216.~~ **Electronic Identification.** A form of unique, permanent individual animal identification such as radio frequency identification tag, radio frequency identification implant, or other forms approved by the Administrator. (3-15-22)

~~2317.~~ **Endemic Area.** A geographical area designated by a state animal health official in the state of origin where animals located within that area are subject to an increased risk of acquiring a contagious disease. Most

commonly in reference to Tuberculosis or Chronic Wasting Disease. (3-15-22)

2418. Escape. Any domestic cervidae located outside the perimeter fence of a domestic cervidae ranch and not under the immediate control of the owner or operator of the domestic cervidae ranch. (3-15-22)

2519. Federal Animal Health Official. An employee of USDA/APHIS/VS who is authorized to perform animal health activities. (3-15-22)

260. Harvest. Any healthy domestic cervid that is intentionally and lethally removed from a domestic cervidae facility, by an owner, designated employee or customer of the facility, strictly for the purposes of either shooting or meat production. Harvested includes cervids slaughtered at an approved or custom-exempt slaughter establishment. (3-15-22)

271. Herd of Origin. A cervid herd, on any domestic cervidae ranch or other premise, where the animals were born, or where they were kept for at least one (1) year prior to date of shipment. (3-15-22)

282. Herd Status. Classification of a cervidae herd with regard to CWD. (3-15-22)

293. Intrastate Movement Certificate. A form approved by the Administrator, and available from the Division, to document the movement of domestic cervidae between premises within Idaho. (3-15-22)

3024. Individual CWD Herd Plan. A written herd management agreement and testing plan developed by the herd owner and approved by the Administrator to identify and eradicate CWD from a positive, source, suspect, exposed, or adjacent herd. (3-15-22)

~~**31. Limited Contact.** Incidental contact between animals of different herds in separate pens off of the herd's premises at fairs, shows, exhibitions and sales. (3-15-22)~~

~~**3225. National CWD Herd Certification Program.** A federal-state-industry cooperative program administered by APHIS and implemented by participating states that establishes CWD surveillance and testing standards that owners must achieve before interstate transport of cervids will be permitted. (3-15-22)~~

~~**3326. Official CWD Test.** A test approved by the Administrator and conducted at an approved laboratory to diagnose CWD where both obex and medial retropharyngeal lymph node samples were submitted for testing. (3-15-22)()~~

~~**3427. Official Identification.** Identification, approved by the Administrator, that individually, uniquely, and permanently identifies each cervid. (3-15-22)~~

~~**3528. Operator.** A person who has authority to manage or direct a domestic cervidae ranch. (3-15-22)~~

~~**3629. Premises.** The ground, area, buildings, and equipment utilized to raise, propagate, control, or harvest domestic cervidae. (3-15-22)~~

~~**370. Quarantine.** An order issued on authority of the Administrator, by a state or federal animal health official or accredited veterinarian, prohibiting movement of cervids from any location without a written restricted movement permit. (3-15-22)~~

~~**381. Quarantine Facility.** A confined area where selected domestic cervidae can be secured and isolated from all other cervidae and livestock. (3-15-22)~~

~~**392. Ranch Management Plan.** A written plan for a domestic cervidae ranch that sets forth best management practices that mitigates the introduction or dissemination of disease among domestic cervidae. (3-15-22)~~

~~**4033. Reidentification.** The identification of a domestic cervid which had been officially identified, as provided by this chapter, but which has lost the official identification device, or the tattoo or official identification~~

device has become illegible. (3-15-22)

4134. Restrain. The immobilization of domestic cervidae in a chute, other device, or by other means for the purpose of efficiently, effectively, and safely inspecting, treating, vaccinating, or testing. (3-15-22)

4235. Restricted Movement Permit. An official document that is issued by the Administrator, AVIC, or an accredited veterinarian for movement of animals from positive, suspect, or exposed herds. (3-15-22)

4336. Source Herd. The herd or herds from where a producer acquired their existing livestock. (3-15-22)

4437. State Animal Health Official. The Administrator, or Administrator's designee. (3-15-22)

4538. Status Date. The date on which the Administrator approves in writing a herd status change with regard to CWD. (3-15-22)

39. Tissues. The obex and medial retropharyngeal lymph node (MRPLN) tissue required for screening elk and deer for Chronic Wasting Disease. ()

460. Trace Back Herd. An exposed herd in which at least one (1) CWD positive animal resided within any of the previous sixty (60) months prior to diagnosis with CWD. (3-15-22)

471. Trace Forward Herd. A herd that has received exposed animals from a positive herd within sixty (60) months prior to the diagnosis of CWD in the positive herd or from the identified point of entry of CWD into the positive herd. (3-15-22)

482. Traceback. The process of identifying the movements and the herd of origin of CWD positive, or exposed animals, including herds that were sold for slaughter. (3-15-22)

493. Wild Cervidae. Any cervid animal not owned by a person. (3-15-22)

5044. Wild Ungulate. Any four (4) legged, hoofed herbivore, including cervids and other ruminants, not owned by a person. (3-15-22)

5145. Wild Ungulate Cooperative Herd Plan. A plan, developed cooperatively by the owner of the domestic cervidae ranch, the ISDA, and the Idaho Department of Fish and Game to determine the disposition of any wild ungulates that are found to be located on a domestic cervidae ranch. (3-15-22)

(BREAK IN CONTINUITY OF SECTIONS)

500. SURVEILLANCE FOR CWD.

01. Routine Surveillance. ~~Brain tissue~~ Obex and medial retropharyngeal lymph node tissues from domestic elk and reindeer sixteen (16) months of age or older at the time of death must be submitted annually to official laboratories for CWD testing as provided for in these rules, under the following conditions: ~~(3-15-22)~~ ()

a. No less than ten percent (10%) of cervids harvested or slaughtered. (3-15-22)

b. No less than one hundred percent (100%) of cervids that die for any reason other than slaughter or harvest. (3-15-22)

c. Tissues samples submitted to an official laboratory that are untestable or are given an indeterminate test result do not count towards the tissue submission requirement. (3-15-22)

d. Fallow deer are exempt from CWD testing. (3-15-22)

02. Enhanced Surveillance. ~~Brain + Tissues~~ from one hundred percent (100%) of all domestic elk and reindeer sixteen (16) months of age or older that die for any reason on a facility will be required to be tested for CWD for a period of sixty (60) months under the following conditions: (3-15-22)()

a. A facility has imported cervids from a location within twenty-five (25) miles from a confirmed case of CWD in wild cervids. (3-15-22)

b. A facility has received cervids via intrastate movement from a facility under enhanced CWD surveillance requirements at the time of the transfer. (3-15-22)

c. The duration of the enhanced CWD surveillance requirements are based upon the most recent date of movement that meets the criteria listed in this section. (3-15-22)

501. COLLECTION OF SAMPLES FOR CWD TESTING.

Obex and medial retropharyngeal lymph node samples must be collected immediately upon discovery of the death of a domestic cervid. (3-15-22)()

01. Non-Testable or Samples That Do not Contain Appropriate Tissues. The Administrator may conduct an investigation to determine if a domestic cervidae ranch is complying with the provisions of Section 500 if the owner or operator of a domestic cervidae ranch submits samples for CWD testing which cannot be identified to the animal of origin. (3-15-22)

02. Failure to Meet Annual CWD Tissue Submission Requirement. An owner or operator of a domestic cervidae ranch who fails to submit samples for CWD testing or who fails to meet the annual tissue submission requirements of this chapter, or both, is in violation of these rules, except the Administrator may approve, in writing, a variance from sample submission requirements on a case specific basis. (3-15-22)

(BREAK IN CONTINUITY OF SECTIONS)

504. INVESTIGATION OF CWD.

An epidemiological investigation will be conducted on all CWD positive, suspect, and exposed animals and herds, herds of origin, source herds, all adjacent herds, and all trace herds as determined by the Administrator. (3-15-22)

01. Quarantine. ~~All positive, suspect, and exposed herds or animals, herds of origin, adjacent herds, and herds having contact with positive or exposed animals must be quarantined; and~~ A quarantine shall be applied to all CWD-exposed, CWD-suspect, and CWD-positive herds and animals following an epidemiological investigation that confirms such status as defined in this section. (3-15-22)()

02. Identification. CWD suspect and exposed animals must be identified and remain on the premises where they are found until they have met the provisions for release of quarantine established in this chapter, are destroyed and disposed of as directed by the Administrator, or are moved at the Administrator's direction on a restricted movement permit. (3-15-22)

03. Multi-Facility Ranches. Multi-facility ranches under quarantine may move animals from one facility to another facility owned by the same entity for the purpose of harvest with the approval of the Director of the Idaho State Department of Agriculture. ()

505. DURATION OF CWD QUARANTINE.

Quarantines imposed because of CWD in accordance with this chapter remain in effect until one (1) of the following criteria are met: (3-15-22)

01. CWD Positive Herds. The quarantine may be released after the herd is completely depopulated as provided in Subsection 505.07, or after five (5) years of compliance with an individual herd CWD plan and all provisions of these rules, during which there was no evidence of CWD. (3-15-22)

02. CWD Suspect Herds. The quarantine may be released after the herd is completely depopulated as provided in Subsection 505.07, or after a minimum of five (5) years of compliance with an individual CWD herd plan and all provisions of these rules and during which there was no evidence of CWD, or an epidemiologic investigation determines that there is no evidence CWD exists in the herd as determined by the Administrator. (3-15-22)

03. Source Herds and Herds of Origin. The quarantine may be released after a minimum of five (5) years of compliance with an individual CWD herd plan and all provisions of these rules and during which there was no evidence of CWD, or an epidemiologic investigation determines that there is no evidence CWD exists in the herd and that the herd is not the source of infection as determined by the Administrator. (3-15-22)

04. Exposed Herds. The quarantine may be released after the herd is completely depopulated as provided in Subsection 505.07, or after a minimum of five (5) years of compliance with an individual CWD herd plan and all provisions of these rules and during which there was no evidence of CWD, or an epidemiologic investigation determines that there is no evidence CWD exists in the herd as determined by the Administrator. (3-15-22)

05. Adjacent Herds. The quarantine may be released when directed by the Administrator based upon an epidemiological investigation and in consultation with the designated epidemiologist. (3-15-22)

06. Fencing Requirements. Any owner of a domestic cervidae ranch who chooses to remain under quarantine for five (5) years must ~~construct a second~~ maintain perimeter ~~fence that meets the requirements for perimeter fence, as provided in Section 102, such that no domestic cervidae on the domestic cervidae ranch can get within ten (10) feet of the original exterior perimeter fence or as approved by the Administrator~~ fencing pursuant to Idaho Code 25-3705C and Section 102 of this rule. (3-15-22)()

07. Complete Depopulation. The quarantine may be released after: (3-15-22)

a. Complete depopulation of all cervidae on the premises as directed by the Administrator; and (3-15-22)

b. The premises have been free of all livestock as specified in an individual CWD herd plan approved by the Administrator; and (3-15-22)

c. The soil and facilities have been cleaned, treated, decontaminated, or disinfected as directed by the Administrator. (3-15-22)

08. Disposal of Positive or Exposed Cervidae. All CWD positive or exposed domestic cervidae must be disposed of as directed by the Administrator. (3-15-22)

IDAPA 02 – IDAHO STATE DEPARTMENT OF AGRICULTURE

02.05.01 – RULES GOVERNING PRODUCE SAFETY

DOCKET NO. 02-0501-2401 (ZBR CHAPTER REWRITE)

NOTICE OF RULEMAKING – PROPOSED RULE

AUTHORITY: In compliance with Section 67-5221(1), Idaho Code, notice is hereby given that this agency has initiated proposed rulemaking procedures. The action is authorized pursuant to Section 22-5404, Idaho Code.

PUBLIC HEARING SCHEDULE: Public hearing(s) concerning this rulemaking will be scheduled if requested in writing by twenty-five (25) persons, a political subdivision, or an agency, not later than October 16, 2024.

The hearing site(s) will be accessible to persons with disabilities. Requests for accommodation must be made not later than five (5) days prior to the hearing, to the agency address below.

DESCRIPTIVE SUMMARY: The following is a nontechnical explanation of the substance and purpose of the proposed rulemaking.

This rule is being presented for authorization as part of the ISDA’s plan to review each rule every 5 years. Redundant language that is verbatim in statute has been removed, consistent with the Governor’s [Zero-Based Regulation Executive Order](#).

The rule was reviewed over the course of two negotiated rulemaking meetings, and that review benefited from the participation of program stakeholders. No negative comments were submitted as part of this rulemaking process.

This rule clarifies the procedure for administering the Food Safety Modernization Act and remedies of the Department for non-compliance.

FEE SUMMARY: The following is a specific description of the fee or charge imposed or increased:

There is no change in fee or charge.

FISCAL IMPACT: The following is a specific description, if applicable, of any negative fiscal impact on the state General Fund greater than ten thousand dollars (\$10,000) during the fiscal year resulting from this rulemaking: There is no fiscal impact on the state General Fund greater than ten thousand dollars (\$10,000).

NEGOTIATED RULEMAKING: Pursuant to Section 67-5220(1), Idaho Code, negotiated rulemaking was conducted. The Notice of Intent to Promulgate Rules - Negotiated Rulemaking was published in the July 3, 2024 Idaho Administrative Bulletin, [Volume 24-7, Pages 47 and 48](#).

INCORPORATION BY REFERENCE: Pursuant to Section 67-5229(2)(a), Idaho Code, the following is a brief synopsis of why the materials cited are being incorporated by reference into this rule:

The federal Food and Drug Administration made several edits to the CFR. This included deleting redundant language and clarifying pre-harvest water requirements.

IDAHO CODE SECTION 22-101A STATEMENT: Pursuant to 22-101A(1), for any rule promulgated or adopted by the director which is broader in scope or more stringent than federal law or regulations, or which regulates an activity not regulated by the federal government, the director shall identify the portions of the adopted rule that are broader in scope or more stringent than federal law or rules, or which regulate an activity not regulated by the federal government. The following sections of the rule are broader in scope, more stringent than federal law or regulations, or regulate an activity not regulated by the federal government:

The federal government does regulate the Food Safety Modernization Act (FSMA). Per Title 22, Chapter 54, Idaho Code, the agency is authorized to administer and enforce FSMA through this rule, and are not to exceed the standards required by federal law.

The detailed 22-101A analysis can be found on the agency’s website at www.agri.idaho.gov.

ASSISTANCE ON TECHNICAL QUESTIONS, SUBMISSION OF WRITTEN COMMENTS: For assistance on technical questions concerning the proposed rule, contact Lloyd Knight at lloyd.knight@isda.idaho.gov.

Anyone may submit written comments regarding this proposed rulemaking. All written comments must be directed to the undersigned and must be delivered on or before October 23, 2024.

DATED this 2nd day of October, 2024.

Lloyd Knight
Deputy Director
Idaho Department of Agriculture
2270 Old Penitentiary Road
P.O. Box 7249
Boise, Idaho 83707
Phone: (208) 332-8615
Email: lloyd.knight@isda.idaho.gov

THE FOLLOWING IS THE PROPOSED TEXT OF DOCKET NO. 02-0501-2401
(ZBR Chapter Rewrite)

02.05.01 – RULES GOVERNING PRODUCE SAFETY

000. LEGAL AUTHORITY.

~~This chapter is adopted under the legal authority of~~ Section 22-5404, Idaho Code. (3-31-22)()

001. ~~TITLE AND SCOPE.~~

~~01. Title.~~ The title of this chapter is “Rules Governing Produce Safety.” (3-31-22)

~~02. Scope.~~ The purpose of these rules is to establish standards for growing, harvesting, packing, and holding of safe and unadulterated produce for human consumption. (3-31-22)()

002. INCORPORATION BY REFERENCE.

~~The following document is incorporated by reference pursuant to Idaho Code Section 67-5229. Copies of this document may be obtained from the Idaho State Department of Agriculture central office.~~ (3-31-22)

~~01. Code of Federal Regulations, Title 21, Part 112, January 1, 2018~~ **July 5, 2024**. Standards for the Growing, Harvesting, Packing, and Holding of Produce for Human Consumption. This document can be viewed online at <https://www.ecfr.gov/cgi-bin/text-idx?SID=7f8ab876ff3e20e6edd06e9de9141296&mc=true&node=pt21.2.112&rgn=div5> <https://www.fda.gov/food/food-safety-modernization-act-fsma/fsma-final-rule-pre-harvest-agricultural-water>. (3-31-22)()

003. – ~~0011.~~ (RESERVED)

~~010. DEFINITIONS.~~

~~The Idaho State Department of Agriculture adopts the definitions set forth in Section 22-5403, Idaho Code. In addition as used in this chapter:~~ (3-31-22)

~~01. **Petition.** A petition for submission to the U.S. Food and Drug Administration requesting a variance from the requirements of 21 CFR Part 112. (3-31-22)~~

~~02. **Petitioner.** An individual, business, group, association, or entity who submits a petition to the Department for submission to the U.S. Food and Drug Administration requesting a variance from the requirements of 21 CFR Part 112. (3-31-22)~~

~~011. **ABBREVIATIONS.**~~

~~01. **FDA.** The U.S. Food and Drug Administration. (3-31-22)~~

012. VARIANCE.

~~01. **Procedure for Seeking a Variance.** Under the Produce Safety Rule, only a State, tribe, or a foreign country may request a variance from the Produce Safety Rule's requirements by submitting a petition to the FDA in accordance with Subpart P of the Produce Safety Rule and with 21 CFR 10.30. Pursuant to 22-5404, Idaho Code, the Idaho Legislature designated the Department to administer the Produce Safety Rule, which includes the authority to decide whether to submit petitions to the FDA. The Department will submit a petition to the FDA if the following procedures are followed: (3-31-22)~~

~~a01. **Submission of Variance.** The petitioner must prepare the petition in accordance with the requirements of Subpart P of the Produce Safety Rule and 21 CFR 10.30. Additionally, the petitioner must attach all required documentation and any other supporting documentation. The petitioner must submit the petition and all attached documents to the Department via the Department's food safety email at fsma@isda.idaho.gov or mailed to the Department at the mailing address above or hand delivered to the Department at the physical address above. The petitioner must submit the petition and all attached documents to the Department via the Department's food safety email at fsma@isda.idaho.gov or mailed or hand delivered to the Department. (3-31-22)()~~

~~ba. Within thirty (30) days of receiving a petition, the Department will complete a review of a petition to determine whether it meets the requirements of Subpart P of the Produce Safety Rule and 21 CFR 10.30. If the Department determines the petition meets all relevant requirements, the Department will submit the petition to the FDA within ten (10) days of that determination. (3-31-22)()~~

~~i. If, after reviewing the petition, the Department determines that the petition meets the requirements of Subpart P of the Produce Safety Rule and 21 CFR 10.30, the Department will submit the petition to the FDA within ten (10) days of that determination. (3-31-22)~~

~~ii. If, after reviewing the petition, the Department determines that the petition does not meet the requirements of Subpart P of the Produce Safety Rule and 21 CFR 10.30, the Department will notify the petitioner and return the petition for correction. After correcting the deficiencies, the petitioner must resubmit the petition to the Department. Within thirty (30) days, the Department will complete an additional review of the petition to determine if the petition meets the requirements of Subpart P of the Produce Safety Rule and 21 CFR 10.30. If the Department determines that the initial petition or any subsequent version is deficient, the Department will notify the petitioner and return the petition for correction. After correcting the deficiencies, the petitioner must resubmit the petition to the Department for evaluation pursuant to subsection 2 of this section. (3-31-22)()~~

~~iii. If, after reviewing the petition, the Department determines that the petition meets the requirements of Subpart P of the Produce Safety Rule and 21 CFR 10.30, the Department will submit the petition to the FDA within ten (10) days of that determination. If, after reviewing the petition, the Department determines that the petition still does not meet the requirements of Subpart P of the Produce Safety Rule and 21 CFR 10.30, the Department will follow the procedure in Subparagraph 012.01.b.ii. (3-31-22)~~

02. Support and Withdrawal of Petitions. (3-31-22)

a. When the Department submits a petition to the FDA, the petitioner who prepared the petition, or an individual, business, group, association, or entity that supports the petition, shall assist the Department in responding to inquiries or directions from the FDA regarding the petition. If neither the petitioner nor an individual, business,

group, association, or entity that supports the petition provides this assistance to the Department within thirty (30) days, the Department may withdraw the petition. (3-31-22)

b. If the FDA takes action to modify or revoke a variance previously granted to the Department, the Department may waive the opportunity for a hearing unless a petitioner or an interested person adequately supports the Department in defending the variance in whole or in part from modification or revocation by FDA. (3-31-22)

013. – 999. (RESERVED)

IDAPA 02 – IDAHO STATE DEPARTMENT OF AGRICULTURE

02.06.02 – RULES GOVERNING REGISTRATIONS AND LICENSES

DOCKET NO. 02-0602-2401

NOTICE OF RULEMAKING – PROPOSED RULE

AUTHORITY: In compliance with Section 67-5221(1), Idaho Code, notice is hereby given that this agency has initiated proposed rulemaking procedures. The action is authorized pursuant to Sections 22-604, 22-2204, 22-2303 (5), 22-2503, 22-2511, and 25-2710.

PUBLIC HEARING SCHEDULE: Public hearing(s) concerning this rulemaking will be scheduled if requested in writing by twenty-five (25) persons, a political subdivision, or an agency, not later than October 16, 2024.

The hearing site(s) will be accessible to persons with disabilities. Requests for accommodation must be made not later than five (5) days prior to the hearing, to the agency address below.

DESCRIPTIVE SUMMARY: The following is a nontechnical explanation of the substance and purpose of the proposed rulemaking:

The proposed rule updates the publication dates for the Official Publications of the American Association of Feed Control Officials and the American Association of Plant Food Control Officials. The two publications are incorporated into this rule as standardized regulations for three subchapters of this rule – Commercial Feed, Commercial Fertilizer, and Soil and Plant Amendments.

The updates to these documents include refinements to definitions, technical terms, and other standards necessary for regulation that meets state statutes as well as the national cooperation in regulating these products.

FEE SUMMARY: The following is a specific description of the fee or charge imposed or increased:

There is no change in fee or charge.

FISCAL IMPACT: The following is a specific description, if applicable, of any negative fiscal impact on the state General Fund greater than ten thousand dollars (\$10,000) during the fiscal year resulting from this rulemaking:

There is no fiscal impact on the state General Fund greater than ten thousand dollars (\$10,000).

NEGOTIATED RULEMAKING: Pursuant to Section 67-5220(2), Idaho Code, negotiated rulemaking was not conducted because these changes are to the publication dates of documents that were already incorporated into these rules.

INCORPORATION BY REFERENCE: Pursuant to Section 67-5229(2)(a), Idaho Code, the following is a brief synopsis of why the materials cited are being incorporated by reference into this rule:

IDAPA 02.06.02 {...} 104. INCORPORATION BY REFERENCE:

01. The Association of American Feed Control Officials (AAFCO) Official Publication. The Terms, Ingredient Definitions, Model Bill and Regulations, and Policies as published in the “2025 Official Publication” of AAFCO where those statements do not conflict with Title 25, Chapter 27, Idaho Code, and any rule promulgated thereunder. A copy may be purchased online from the AAFCO website at: www.aafco.org.

IDAPA 02.06.02 {...} 404. INCORPORATION BY REFERENCE:

01. The Association of American Plant Food Control Officials (AAPFCO) Official Publication. The Officially adopted Documents, Official Terms, and Policies, as published in the “2025 Official Publication” of AAPFCO where those statements do not conflict with Title 22, Chapter 6, Idaho Code, and any rule promulgated thereunder. A copy may be purchased online from the AAPFCO website at: www.aapfco.org.

IDAPA 02.06.02 {...} 504. INCORPORATION BY REFERENCE:

01. The Association of American Plant Food Control Officials (AAPFCO) Official Publication. The Terms, Ingredient Definitions, and Policies as published in the “2025 Official Publication” of AAPFCO where those terms and ingredient definitions, and policy statements do not conflict with terms and ingredient definitions, and policy statements adopted under Title 22, Chapter 22, Idaho Code, and any rule promulgated thereunder. A copy may be purchased online from the AAPFCO website at: www.aapfco.org.

IDAHO CODE SECTION 22-101A STATEMENT: Pursuant to 22-101A(1), for any rule promulgated or adopted by the director which is broader in scope or more stringent than federal law or regulations, or which regulates an activity not regulated by the federal government, the director shall identify the portions of the adopted rule that are broader in scope or more stringent than federal law or rules, or which regulate an activity not regulated by the federal government. The following sections of the rule are broader in scope, more stringent than federal law or regulations, or regulate an activity not regulated by the federal government:

This rule implements regulatory activities and requirements directed and authorized in Idaho Code. As these are directed in statute, they are not directly regulated by the federal government.

The detailed 22-101A analysis can be found on the agency’s website at www.agri.idaho.gov.

ASSISTANCE ON TECHNICAL QUESTIONS, SUBMISSION OF WRITTEN COMMENTS: For assistance on technical questions concerning the proposed rule, contact Lloyd Knight at lloyd.knight@isda.idaho.gov.

Anyone may submit written comments regarding this proposed rulemaking. All written comments must be directed to the undersigned and must be delivered on or before October 23, 2024.

DATED this 2nd day of October, 2024.

Lloyd Knight
Deputy Director
Idaho Department of Agriculture
2270 Old Penitentiary Road
P.O. Box 7249
Boise, Idaho 83707
Phone: (208) 332-8615
Email: lloyd.knight@isda.idaho.gov.

THE FOLLOWING IS THE PROPOSED TEXT OF DOCKET NO. 02-0602-2401
(Only Those Sections With Amendments Are Shown.)

02.06.02 – RULES GOVERNING REGISTRATIONS AND LICENSES

104. INCORPORATION BY REFERENCE.

The following documents are incorporated by reference into this Subchapter A: (3-23-23)

01. The Association of American Feed Control Officials (AAFCO) Official Publication. The Terms, Ingredient Definitions, Model Bill and Regulations, and Policies as published in the “2024⁵ Official Publication” of AAFCO where those statements do not conflict with Title 25, Chapter 27, Idaho Code, and any rule promulgated thereunder. A copy may be purchased online from the AAFCO website at: www.aafco.org.

(7-1-24)()

02. The Merck Index. The “Merck Veterinary Manual,” 11th Edition, as published by Merck Research Laboratories Division of Merck & Co., Incorporated. The manual is publicly available online from Merck & Co., Inc at: <http://www.rsc.org/merckindex>. (3-23-23)

(BREAK IN CONTINUITY OF SECTIONS)

404. INCORPORATION BY REFERENCE.

The following documents are incorporated by reference into Subchapter C: (3-23-23)

01. The Association of American Plant Food Control Officials (AAPFCO) Official Publication. The Officially adopted Documents, Official Terms, and Policies, as published in the “2024⁵ Official Publication” of AAPFCO where those statements do not conflict with Title 22, Chapter 6, Idaho Code, and any rule promulgated thereunder. A copy may be purchased online from the AAPFCO website at: www.aafco.org. (7-1-24)()

02. The Association of Official Agricultural Chemists (AOAC) International. The “2019 Official Methods of Analysis (OMA) of the AOAC,” 21st Edition, a copyrighted publication, is maintained and published by the AOAC International. The AOAC OMA is available in electronic format at: www.EOMA.AOAC.org. A copy may be purchased online from AOAC International. (3-23-23)

(BREAK IN CONTINUITY OF SECTIONS)

504. INCORPORATION BY REFERENCE.

The following documents are incorporated by reference into Subchapter D: (3-23-23)

01. The Association of American Plant Food Control Officials (AAPFCO) Official Publication. The Terms, Ingredient Definitions, and Policies, as published in the “2024⁵ Official Publication” of AAPFCO where those terms and ingredient definitions, and policy statements do not conflict with terms and ingredient definitions, and policy statements adopted under Title 22, Chapter 22, Idaho Code, and any rule promulgated thereunder. A copy may be purchased online from the AAPFCO website at: www.aapfco.org. (7-1-24)()

02. The Association of Official Agricultural Chemists (AOAC) International. The “2019 Official Methods of Analysis (OMA) of the AOAC,” 21st Edition, a copyrighted publication, is maintained and published by the AOAC International. The AOAC OMA is available in electronic format at: www.EOMA.AOAC.org. A copy may be purchased online from AOAC International. (3-23-23)

IDAPA 02 – IDAHO STATE DEPARTMENT OF AGRICULTURE
02.06.09 – RULES GOVERNING INVASIVE SPECIES AND NOXIOUS WEEDS
DOCKET NO. 02-0609-2402
NOTICE OF RULEMAKING – PROPOSED RULE

AUTHORITY: In compliance with Section 67-5221(1), Idaho Code, notice is hereby given that this agency has initiated proposed rulemaking procedures. The action is authorized pursuant to Section 22-2403, Idaho Code.

PUBLIC HEARING SCHEDULE: Public hearing(s) concerning this rulemaking will be scheduled if requested in writing by twenty-five (25) persons, a political subdivision, or an agency, not later than October 16, 2024.

The hearing site(s) will be accessible to persons with disabilities. Requests for accommodation must be made not later than five (5) days prior to the hearing, to the agency address below.

DESCRIPTIVE SUMMARY: The following is a nontechnical explanation of the substance and purpose of the proposed rulemaking.

The department received two separate petitions proposing new additions to the Noxious Weed List – one for Palmar amaranth and one for Myrtle spurge. Palmar amaranth is a weed species found in agricultural crop lands. Myrtle spurge is a landscaping species. Both species have either had an impact on agricultural production or present a threat to landscapes or native species. Both have degrees of prevalence in the state.

In addition, the agency is proposing to reduce categorization of Turkish thistle from EDRR to Control category and to add EDRR language that was missed during the last rulemaking session.

Two negotiated rulemaking meetings were held, and participation includes stakeholders from weed management agencies, cooperators, agricultural industry, and the general public. There was not consensus on the petitions for listing of the two species. Those species are not proposed to be listed in this Proposed Rule. No negative comments were submitted about the re-categorization of Turkish Thistle or adding the EDRR language.

FEE SUMMARY: The following is a specific description of the fee or charge imposed or increased:

There is no change in fee or charge.

FISCAL IMPACT: The following is a specific description, if applicable, of any negative fiscal impact on the state General Fund greater than ten thousand dollars (\$10,000) during the fiscal year resulting from this rulemaking:

There is no fiscal impact on the state General Fund greater than ten thousand dollars (\$10,000).

NEGOTIATED RULEMAKING: Pursuant to Section 67-5220(1), Idaho Code, negotiated rulemaking was conducted. The Notice of Intent to Promulgate Rules - Negotiated Rulemaking was published in the July 3, 2024 Idaho Administrative Bulletin, [Volume 24-7, Pages 49 and 50](#).

INCORPORATION BY REFERENCE: Pursuant to Section 67-5229(2)(a), Idaho Code, the following is a brief synopsis of why the materials cited are being incorporated by reference into this rule:

There are no changes to documents already incorporated by reference.

IDAHO CODE SECTION 22-101A STATEMENT: Pursuant to 22-101A(1), for any rule promulgated or adopted by the director which is broader in scope or more stringent than federal law or regulations, or which regulates an activity not regulated by the federal government, the director shall identify the portions of the adopted rule that are broader in scope or more stringent than federal law or rules, or which regulate an activity not regulated by the federal government. The following sections of the rule are broader in scope, more stringent than federal law or regulations, or regulate an activity not regulated by the federal government:

The federal government does not regulate state invasive species or noxious weeds within the state. This activity is defined in Title 22, Chapter 24, Idaho Code.

The detailed 22-101A analysis can be found on the agency's website at www.agri.idaho.gov.

ASSISTANCE ON TECHNICAL QUESTIONS, SUBMISSION OF WRITTEN COMMENTS: For assistance on technical questions concerning the proposed rule, contact Lloyd Knight at lloyd.knight@isda.idaho.gov.

Anyone may submit written comments regarding this proposed rulemaking. All written comments must be directed to the undersigned and must be delivered on or before October 23, 2024.

DATED this 2nd day of October, 2024.

Lloyd Knight
Deputy Director
Idaho Department of Agriculture
2270 Old Penitentiary Road
P.O. Box 7249
Boise, Idaho 83707
Phone: (208) 332-8615
Email: lloyd.knight@isda.idaho.gov

THE FOLLOWING IS THE PROPOSED TEXT OF DOCKET NO. 02-0609-2402
(Only Those Sections With Amendments Are Shown.)

02.06.09 – RULES GOVERNING INVASIVE SPECIES AND NOXIOUS WEEDS

220. NOXIOUS WEEDS - DESIGNATIONS.

The weeds listed on the Statewide Prohibited Genera, EDRR, Containment, and Control lists are hereby officially designated and published as noxious. (3-15-22)

01. Statewide Prohibited Genera Noxious Weed List. (3-15-22)

a. All plants and plant parts in the genera of: *Cytisus*, *Genista*, *Spartium*, and *Chamaecytisus* additionally including “all” subtaxa of these plant genera are prohibited in Idaho. (3-15-22)

b. Weeds listed in the Prohibited Genera list may exist in varying populations throughout the state. The concentration of these weeds is at a level where control and/or eradication may be possible. A written plan for weeds on the Statewide Prohibited Genera Noxious Weed List shall be developed by the control authority that specifies active control methods to reduce known populations in not more than five (5) years. The plan shall be available to the Department upon request. (3-15-22)

02. Statewide EDRR Noxious Weed List. Weeds listed in the EDRR list are not known to exist in Idaho, however, have the potential to become established, or are known to exist in Idaho in small enough infestations that eradication is possible. If any of the listed plants (Subsection 220.02) are found to occur in Idaho, they shall be reported to the Department within ten (10) days following positive identification by the University of Idaho or other

qualified authority as approved by the Director. These weeds shall be eradicated during the same growing season as identified.

	Common Name	Scientific Name
1.	Brazilian Elodea	<i>Egeria densa</i>
2.	Cogongrass	<i>Imperata cylindrica</i>
3.	Common/European Frogbit	<i>Hydrocharis morsus-ranae</i>
4.	Fanwort	<i>Cabomba caroliniana</i>
5.	Feathered Mosquito Fern	<i>Azolla pinnata</i>
6.	Giant Hogweed	<i>Heracleum mantegazzianum</i>
7.	Giant Salvinia	<i>Salvinia molesta</i>
8.	Goatsrue	<i>Galega officinalis</i>
9.	Hydrilla	<i>Hydrilla verticillata</i>
10.	Iberian Starthistle	<i>Centaurea iberica</i>
11.	Policeman’s Helmet	<i>Impatiens glandulifera</i>
12.	Purple Starthistle	<i>Centaurea calcitrapa</i>
13.	Squarrose Knapweed	<i>Centaurea triumfetti</i>
14.	Starry Stonewort	<i>Nitellopsis obtusa</i>
15.	Syrian Beancaper	<i>Zygophyllum fabago</i>
16.	Tall Hawkweed	<i>Hieracium piloselloides</i>
17.	Turkish Thistle	<i>Carduus cinereus</i>
18. 7.	Variable-Leaf-Milfoil	<i>Myriophyllum heterophyllum</i>
19. 8.	Water Chestnut	<i>Trapa natans</i>
20. 19.	Water Hyacinth	<i>Eichhornia crassipes</i>
24. 0.	Yellow Devil Hawkweed	<i>Hieracium glomeratum</i>
22. 1.	Yellow Floating Heart	<i>Nymphoides pelata</i>

(7-1-24)()

03. Statewide Control Noxious Weed List. Weeds listed in the control list are known to exist in varying populations throughout the state. The concentration of these weeds is at a level where control or eradication, or both, may be possible. A written plan for weeds on the Statewide Control Noxious Weed List shall be developed by the control authority that specifies active control methods to reduce known populations in not more than five (5) years. The plan shall be available to the Department upon request.

	Common Name	Scientific Name
1.	Black Henbane	<i>Hyoscyamus niger</i>
2.	Bohemian Knotweed	<i>Polygonum X bohemicum</i>

	Common Name	Scientific Name
3.	Common Crupina	<i>Crupina vulgaris</i>
4.	Common Reed (Phragmites)	<i>Phragmites australis</i>
5.	Dyer's Woad	<i>Isatis tinctoria</i>
6.	Eurasian Watermilfoil	<i>Myriophyllum spicatum</i> (and hybrids)
7.	Flowering Rush	<i>Butomus umbellatus</i>
8.	Giant Knotweed	<i>Polygonum sachalinense</i>
9.	Japanese Knotweed	<i>Polygonum cuspidatum</i>
10.	Johnsongrass	<i>Sorghum halepense</i>
11.	Matgrass	<i>Nardus stricta</i>
12.	Meadow Knapweed	<i>Centaurea debeauxii</i>
13.	Mediterranean Sage	<i>Salvia aethiopsis</i>
14.	Musk Thistle	<i>Carduus nutans</i>
15.	Orange Hawkweed	<i>Hieracium aurantiacum</i>
16.	Parrotfeather Milfoil	<i>Myriophyllum aquaticum</i>
17.	Perennial Sowthistle	<i>Sonchus arvensis</i>
18.	Russian Knapweed	<i>Acroptilon repens</i>
19.	Scotch Broom	<i>Cytisus scoparius</i>
20.	Small Bugloss	<i>Anchusa arvensis</i>
21.	Turkish Thistle	<i>Carduus cinereus</i>
24.	Vipers Bugloss	<i>Echium vulgare</i>
23.	Yellow Hawkweed	<i>Hieracium caespitosum</i>

(7-1-24)()

04. **Statewide Containment Noxious Weed List.** Weeds listed in the containment noxious weeds list are known to exist in various populations throughout the state. Weed control efforts may be directed at reducing or eliminating new or expanding weed populations while known and established weed populations, as determined by the weed control authority, may be managed by any approved weed control methodology, as determined by the weed control authority.

	Common Name	Scientific Name
1.	Canada Thistle	<i>Cirsium arvense</i>
2.	Curlyleaf Pondweed	<i>Potamogeton crispus</i>
3.	Dalmatian Toadflax	<i>Linaria dalmatica ssp. dalmatica</i>
4.	Diffuse Knapweed	<i>Centaurea diffusa</i>
5.	Field Bindweed	<i>Convolvulus arvensis</i>

	Common Name	Scientific Name
6.	Hoary Alyssum	<i>Berteroa incana</i>
7.	Houndstongue	<i>Cynoglossum officinale</i>
8.	Jointed Goatgrass	<i>Aegilops cylindrica</i>
9.	Leafy Spurge	<i>Euphorbia esula</i>
10.	Milium	<i>Milium vernale</i>
11.	Oxeye Daisy	<i>Leucanthemum vulgare</i>
12.	Perennial Pepperweed	<i>Lepidium latifolium</i>
13.	Plumeless Thistle	<i>Carduus acanthoides</i>
14.	Poison Hemlock	<i>Conium maculatum</i>
15.	Puncturevine	<i>Tribulus terrestris</i>
16.	Purple Loosestrife	<i>Lythrum salicaria</i>
17.	Rush Skeletonweed	<i>Chondrilla juncea</i>
18.	Saltcedar	<i>Tamarix</i> spp.
19.	Scotch Thistle	<i>Onopordum acanthium</i>
20.	Spotted Knapweed	<i>Centaurea stoebe</i>
21.	Tansy Ragwort	<i>Senecio jacobaea</i>
22.	White Bryony	<i>Bryonia alba</i>
23.	Whitetop (Hoary Cress)	<i>Cardaria draba</i>
24.	Yellow Flag Iris	<i>Iris pseudocorus</i>
25.	Yellow Starthistle	<i>Centaurea solstitialis</i>
26.	Yellow Toadflax	<i>Linaria vulgaris</i>

(3-15-22)

05. Designation of Articles Capable of Disseminating Noxious Weeds. The following articles are designated by the Director as capable of disseminating noxious weeds: (3-15-22)

- a.** Construction equipment, road building and maintenance equipment, and implements of husbandry. (3-15-22)
- b.** Motorized vehicles such as, all-terrain vehicles, motorcycles, and other off-road vehicles and non-motorized vehicles such as bicycles and trailers. (3-15-22)
- c.** Grain and seed. (3-15-22)
- d.** Hay, straw and other material of similar nature. (3-15-22)
- e.** Nursery stock including plant material propagated for the support of aquarium, pet, or horticultural activities. (3-15-22)
- f.** Feed and seed screenings. (3-15-22)
- g.** Fence posts, fencing and railroad ties. (3-15-22)

- h.** Sod. (3-15-22)
- i.** Manure, fertilizers and material of similar nature. (3-15-22)
- j.** Soil, sand, mulch, and gravel. (3-15-22)
- k.** Boats, personal watercraft, watercraft trailers, and items of a similar nature. (3-15-22)

IDAPA 02 – DEPARTMENT OF AGRICULTURE
02.06.09 – RULES GOVERNING INVASIVE SPECIES AND NOXIOUS WEEDS
DOCKET NO. 02-0609-2404
NOTICE OF RULEMAKING – ADOPTION OF TEMPORARY RULE

EFFECTIVE DATE: The effective date of the temporary rule is September 26, 2024.

AUTHORITY: In compliance with Sections 67-5226, Idaho Code, notice is hereby given this agency has adopted a temporary rule. The action is authorized pursuant to Sections 22-2004, 22-2006, 22-2012, and 22-2013, Idaho Code.

DESCRIPTIVE SUMMARY: The following is the required finding and concise statement of its supporting reasons for adopting a temporary rule:

Invasive quagga mussel samples were recently discovered in the Snake River. Left unchecked, quagga mussels pose a significant threat to the health and safety of Idaho's environment, and water use as well as threaten Idaho's economy. Accordingly, the Director has exercised the authority granted to them under Idaho law to quarantine certain areas of the Snake River until the Department is able to eradicate any existing quagga mussels. This new temporary rule replaces the June 27, 2024, update to the same rule by allowing for restricted access to the river at defined locations and per a defined requirement for watercraft and conveyances to be inspected and decontaminated and decontaminated as needed prior to launch and decontaminated upon exit.

The new amendment adds a restriction for access to the Snake River for watercraft or other conveyances up to Hansen Bridge.

TEMPORARY RULE JUSTIFICATION: Pursuant to Section 67-5226(1)(a), Idaho Code, the Governor has found that temporary adoption of the rule is appropriate for the following reasons:

Protection for and maintaining the safety of property and aquatic plant life.

FEE SUMMARY: Pursuant to Section 67-5226(2), the Governor has found that the fee or charge being imposed or increased is justified and necessary to avoid immediate danger and the fee is described herein:

There is no fee being charged by this temporary rule.

ASSISTANCE ON TECHNICAL QUESTIONS: For assistance on technical questions concerning the temporary rule, contact Lloyd Knight.

DATED this 26th day of September, 2024.

Lloyd B. Knight, Deputy Director
Idaho State Department of Agriculture
2270 Old Penitentiary Road
P.O. Box 7249
Boise, ID 83707
Phone: (208) 332-8615
Email: lloyd.knight@isda.idaho.gov

THE FOLLOWING IS THE TEXT OF THE TEMPORARY RULE FOR DOCKET NO. 02-0609-2404
(Only Those Sections With Amendments Are Shown.)

135. SNAKE RIVER QUARANTINE.

ISDA has issued a quarantine of the Snake River from ~~Twin Falls Dam~~ Hansen Bridge to the partial bridge structure at the bottom of Yingst Grade (known as “the Broken Bridge”, “Yingst Grade Bridge”, the “Old Interstate Bridge”), which is approximately one-half (1/2) mile upstream of Auger Falls to contain and treat quagga mussels. All public access to the Snake River via watercraft or other conveyance between Pillar Falls and ~~Twin Falls hydroelectric facility~~ Hansen Bridge is prohibited. Access to the river by watercraft or other conveyance between the bottom of Yingst Grade (known as “the Broken Bridge”, “Yingst Grade Bridge”, the “Old Interstate Bridge”), which is approximately one-half (1/2) mile upstream of Auger Falls, and Pillar Falls is restricted. Launch of watercraft or other conveyances in this section is restricted to the hours when the watercraft inspection station at Centennial Park is in operation and requires inspection and decontamination of all conveyances and watercraft by ISDA or an assigned entity prior to launch into and upon exit from the water. This requirement applies to all motorized and non-motorized watercraft or other conveyances of any size, including paddle boards and kayaks. ~~(4-10-24)T~~ (9-26-24)T

01. State and County Watercraft. State and county watercraft, including watercraft operated by the vendor approved by the Twin Falls County to operate at Centennial Park, are permitted to access the area from Pillar Falls to the Shoshone Falls provided the watercraft do not leave the infested area or go through decontamination prior to leaving the quarantine area. All watercraft entering the area between Pillar Falls and Shoshone Falls must launch from Centennial Park, presenting for inspection and decontamination prior to launch into and upon exit from the water. (6-28-24)T

IDAPA 02 – IDAHO STATE DEPARTMENT OF AGRICULTURE

02.06.33 – ORGANIC FOOD PRODUCTS RULES

DOCKET NO. 02-0633-2401

NOTICE OF RULEMAKING – PROPOSED RULE

AUTHORITY: In compliance with Section 67-5221(1), Idaho Code, notice is hereby given that this agency has initiated proposed rulemaking procedures. The action is authorized pursuant to Section 22-1103, Idaho Code.

PUBLIC HEARING SCHEDULE: Public hearing(s) concerning this rulemaking will be scheduled if requested in writing by twenty-five (25) persons, a political subdivision, or an agency, not later than October 16, 2024.

The hearing site(s) will be accessible to persons with disabilities. Requests for accommodation must be made not later than five (5) days prior to the hearing, to the agency address below.

DESCRIPTIVE SUMMARY: The following is a nontechnical explanation of the substance and purpose of the proposed rulemaking:

The proposed rule updates the publication date for the Code of Federal Regulations, Title 7, Part 205, National Organic Program Regulations. This regulation contains the specifications, tolerances, and other technical requirements for maintaining organic accreditation.

FEE SUMMARY: The following is a specific description of the fee or charge imposed or increased:

There is no change in fee or charge

FISCAL IMPACT: The following is a specific description, if applicable, of any negative fiscal impact on the state General Fund greater than ten thousand dollars (\$10,000) during the fiscal year resulting from this rulemaking:

There is no fiscal impact on the state General Fund greater than ten thousand dollars (\$10,000).

NEGOTIATED RULEMAKING: Pursuant to Section 67-5220(2), Idaho Code, negotiated rulemaking was not conducted because these changes are to the publication dates of documents that were already incorporated into these rules.

INCORPORATION BY REFERENCE: Pursuant to Section 67-5229(2)(a), Idaho Code, the following is a brief synopsis of why the materials cited are being incorporated by reference into this rule:

The Code of Federal Regulations, Title 7, Part 205, National Organic Program Regulations was updated to the January 2, 2024 version.

IDAHO CODE SECTION 22-101A STATEMENT: Pursuant to 22-101A(1), for any rule promulgated or adopted by the director which is broader in scope or more stringent than federal law or regulations, or which regulates an activity not regulated by the federal government, the director shall identify the portions of the adopted rule that are broader in scope or more stringent than federal law or rules, or which regulate an activity not regulated by the federal government. The following sections of the rule are broader in scope, more stringent than federal law or regulations, or regulate an activity not regulated by the federal government:

This rule allows the agency to implement the organic certification program specifically according to the National Organic Program Regulations. Incorporating these national regulations ensures that the state program is in compliance with the federal program, to the benefit of the voluntary certification customers served by the agency.

The detailed 22-101A analysis can be found on the agency's website at www.agri.idaho.gov.

ASSISTANCE ON TECHNICAL QUESTIONS, SUBMISSION OF WRITTEN COMMENTS: For assistance on technical questions concerning the proposed rule, contact Lloyd Knight at lloyd.knight@isda.idaho.gov.

Anyone may submit written comments regarding this proposed rulemaking. All written comments must be directed to the undersigned and must be delivered on or before October 23, 2024.

DATED this 2nd day of October, 2024.

Lloyd Knight
Deputy Director
Idaho Department of Agriculture
2270 Old Penitentiary Road
P.O. Box 7249
Boise, Idaho 83707
Phone: (208) 332-8615
Email: lloyd.knight@isda.idaho.gov

THE FOLLOWING IS THE PROPOSED TEXT OF DOCKET NO. 02-0633-2401
(Only Those Sections With Amendments Are Shown.)

02.06.33 – ORGANIC FOOD PRODUCTS RULES

004. INCORPORATION BY REFERENCE.

The Code of Federal Regulations, Title 7, Part 205, National Organic Program Regulations (~~March 20, 2023~~ January 2, 2024), except sections 205.620 through 205.622, is incorporated by reference and can be viewed online at <https://www.ecfr.gov/current/title-7/subtitle-B/chapter-I/subchapter-M/part-205/subpart-G/subject-group-ECFR370552c56dd7aef>. Copies of this document may be obtained from the Idaho State Department of Agriculture (ISDA), 2270 Old Penitentiary Road, Boise, Idaho 83712. ~~(7-1-24)~~ ()

IDAPA 02.08 – IDAHO SHEEP AND GOAT HEALTH BOARD

02.08.01 – SHEEP AND GOAT RULES OF THE IDAHO SHEEP AND GOAT HEALTH BOARD

DOCKET NO. 02-0801-2401 (ZBR CHAPTER REWRITE)

NOTICE OF RULEMAKING – PROPOSED RULE

AUTHORITY: In compliance with Section 67-5221(1), Idaho Code, notice is hereby given that this agency has initiated proposed rulemaking procedures. The action is authorized pursuant to Sections 25-129(1) and 25-147, Idaho Code.

PUBLIC HEARING SCHEDULE: Public hearing(s) concerning this rulemaking will be scheduled if requested in writing by twenty-five (25) persons, a political subdivision, or an agency, not later than October 16, 2024.

The hearing site(s) will be accessible to persons with disabilities. Requests for accommodation must be made not later than five (5) days prior to the hearing, to the agency address below.

DESCRIPTIVE SUMMARY: The following is a nontechnical explanation of the substance and purpose of the proposed rulemaking:

This rule is being presented for authorization as part of the ISGHB's effort to review rules every five years. Redundant language that is verbatim in statute has been removed, consistent with the Governor's [Zero-Based Regulation Executive Order](#).

The rule was reviewed over the course of two negotiated rulemaking meetings, and that review benefited from the participation of program stakeholders. No negative comments were submitted as part of this rulemaking process. This rule governs the health and disease control measures for sheep and goats within the state of Idaho. This includes regulations on disease prevention, identification, interstate movement, and management practices to protect and maintain the health of the state's sheep and goat populations.

The proposed rule includes updates to the publication dates for publications Incorporation by Reference in the rule. The two publications include Code of Federal Regulations and Voluntary Scrapie Flock Certification Program Standards, USDA.

FEE SUMMARY: The following is a specific description of the fee or charge imposed or increased:

No changes have been made to fees for these rules.

FISCAL IMPACT: The following is a specific description, if applicable, of any negative fiscal impact on the state General Fund greater than ten thousand dollars (\$10,000) during the fiscal year resulting from this rulemaking:

There is no fiscal impact due to these changes.

NEGOTIATED RULEMAKING: Pursuant to Section 67-5220(1), Idaho Code, negotiated rulemaking was conducted. The Notice of Intent to Promulgate Rules - Negotiated Rulemaking was published in the June 5, 2024 Idaho Administrative Bulletin, [Vol. 24-6, page 12](#).

INCORPORATION BY REFERENCE: Pursuant to Section 67-5229(2)(a), Idaho Code, the following is a brief synopsis of why the materials cited are being incorporated by reference into this rule:

The documents incorporated by reference in this rule are federal regulations and manuals related to disease. These documents are important to include to ensure that any activities are consistent with the federal regulation and the National Scrapie Eradication Program.

ASSISTANCE ON TECHNICAL QUESTIONS, SUBMISSION OF WRITTEN COMMENTS: For assistance on technical questions concerning the proposed rule, contact Lauren Mink, Executive Secretary, at (208) 803-5084.

Anyone may submit written comments regarding this proposed rulemaking. All written comments must be directed to the undersigned and must be delivered on or before October 23, 2024.

DATED this 30th day of August, 2024.

Lauren Mink
Idaho Sheep and Goat Health Board Executive Secretary
2118 W Airport Way
Boise, Idaho 83705
Phone: (208) 803-5084
Email: lauren.mink@isda.idaho.gov

Idaho Department of Agriculture
2270 Old Penitentiary Road
P.O. Box 7249
Boise, Idaho 83707

THE FOLLOWING IS THE PROPOSED TEXT OF DOCKET NO. 02-0801-2401
(ZBR Chapter Rewrite)

02.08.01 – SHEEP AND GOAT RULES OF THE IDAHO SHEEP AND GOAT HEALTH BOARD

000. LEGAL AUTHORITY.

~~This chapter is adopted under the legal authority of~~ Sections 25-129(1) and 25-147, Idaho Code. (3-23-23)()

001. ~~TITLE AND SCOPE.~~

~~01. Title.~~ The title of this chapter is the “~~Sheep and Goat Rules of the Idaho Sheep and Goat Health Board.~~” (3-23-23)

~~02. Scope.~~ These rules govern procedures for the prevention, control and eradication of diseases among sheep and goats, the interstate and intrastate movement of sheep and goats and the assessment of fees on sheep and goats to provide resources to carry out these functions. (3-23-23)()

002. – 003. (RESERVED)

004. INCORPORATION BY REFERENCE.

Copies of the following documents may be obtained from the Idaho State Department of Agriculture Division of Animal Industries. IDAPA 02.08.01 incorporates by reference: (3-23-23)

~~01. The~~ Code of Federal Regulations Title 9, Parts ~~54.1, 54.2, 54.8, 54.9, 54.10, 54.11, 54.20, 54.21, 54.22 and 79~~, January 1, ~~2015~~ 2024. This document can be viewed online at <https://www.govinfo.gov/content/pkg/CFR-2024-title9-vol1/pdf/CFR-2024-title9-vol1-part54.pdf>. (3-23-23)()

~~02. The~~ Voluntary Scrapie Flock Certification Program Standards, USDA, June ~~2013~~ 2016. This document can be viewed online at https://www.aphis.usda.gov/sites/default/files/standards_current.pdf. (3-23-23)()

~~03. Code of Federal Regulations, Title 9, Part 79, January 1, 2024.~~ This document can be viewed

online at <https://www.govinfo.gov/content/pkg/CFR-2024-title9-vol1/pdf/CFR-2024-title9-vol1-part79.pdf>. ()

~~034.~~ ~~The~~ Code of Federal Regulations, Title 9, Part 161, January 1, ~~2009~~ 2024. This document can be viewed online at <https://www.govinfo.gov/content/pkg/CFR-2024-title9-vol1/pdf/CFR-2024-title9-vol1-part161.pdf>. (3-23-23)()

005. -- 009. (RESERVED)

010. DEFINITIONS.

~~01. Accredited Veterinarian.~~ A veterinarian approved by the Administrator and USDA/APHIS/VS in accordance with provisions of Title 9, Part 161, Code of Federal Regulations to perform functions of State Federal animal disease control programs. (3-23-23)

~~02. Animals.~~ All vertebrates, except humans. (3-23-23)

~~031. Authorized Federal Inspector.~~ An employee of USDA authorized by the Board to perform the functions of the Idaho Sheep and Goat Health Board. (3-23-23)

~~042. Authorized State Inspector.~~ An employee of the state of Idaho authorized by the Board to perform the functions of the Idaho Sheep and Goat Health Board. (3-23-23)

~~053. Board.~~ The Idaho Sheep and Goat Health Board or its designee. (3-23-23)

~~064. Breeding Stock.~~ Intact male or female sheep or goats of any age. (3-23-23)

~~075. Brucellosis.~~ An infectious disease of animals and humans caused by bacteria of the genus *Brucella*. (3-23-23)

~~086. Brucella Ovis Test Positive.~~ An animal that tests in the positive range on an approved *Brucella Ovis* ELISA test. (3-23-23)

~~097. Brucella Ovis Test Suspect.~~ An animal that tests in the suspect range on an approved *Brucella Ovis* ELISA test. (3-23-23)

~~1008. Brucella Ovis Test Negative.~~ An animal that tests in the negative range on an approved *Brucella Ovis* ELISA test. (3-23-23)

~~11. Certificate.~~ An official certificate of veterinary inspection or other approved certificate issued by an accredited veterinarian, state or federal animal health official, or other approved official at the point of origin of the shipment of animal(s) being imported. (3-23-23)

~~1209. Commercial Low-Risk Goats.~~ Intact or castrated goats, raised for fiber or meat, that are not registered or exhibited, that are not scrapie positive, suspect, high risk, or exposed animals and that have not been exposed to sheep or are not from a state that has scrapie in goats. (3-23-23)

~~130. Contemporary Lambing Group.~~ The time from the first birth to sixty (60) days post birthing of the entire group in a given lambing season. (3-23-23)

~~141. Exposed.~~ Animals that have had direct contact with other animals, herds, or materials that have been determined to be infected with or affected by any infectious, contagious, or communicable disease. (3-23-23)

~~152. Federal Animal Health Official.~~ An employee of USDA/APHIS/VS who has been authorized to perform animal health activities. (3-23-23)

~~16. Flock.~~ Flock or flocks are interchangeable with the terms herd or herds and denote a group of one (1) or more animals that are fed, housed and birthed together on the same premises, or animals maintained in separate

~~geographic areas that have interchange at or around the time of birth. Changes in ownership of a flock do not change the identity of the flock or the regulatory requirements applicable to the flock. (3-23-23)~~

~~17. **Flock Plan.** A written flock management agreement signed by the owner, his accredited veterinarian if there is one, a representative of the Division of Animal Industries, and an APHIS representative in which each signatory agrees to undertake action specified in the Flock Plan to eradicate or control scrapie as defined in 9 CFR Part 54.8 a-f. Goats exposed to scrapie will be subjected to the same rules as sheep. (3-23-23)~~

183. Goats Requiring Premises/Flock Identification Number. Sexually intact goats or goats that have resided on the same premises as sheep or any other goats not defined in Subsection 010.13. (3-23-23)

194. Idaho Premises/Flock Identification Number. A unique identification number or alphanumeric designation approved by APHIS, and assigned by the Board to each premises/flock of breeding sheep or goats, as defined in Subsection 010.21, in the state of Idaho. (3-23-23)

2015. Low Risk Commercial Sheep. Commercial whiteface, white-faced cross, or commercial hair sheep from a flock with no known risk factors for scrapie, including any exposure to female black-faced sheep, that are identified with a permanent brand or ear notch pattern registered with an official brand registry and that are not scrapie-positive, suspect, high-risk, or exposed animals and are not animals from an infected, source, or exposed flock. (3-23-23)

216. Negative. Animals are classified as negative when they have been subjected to official tests for a disease, and the tests performed have failed to disclose evidence of the disease. (3-23-23)

2217. Official Individual Identification. The unique identification of individual animals with an alpha numeric number applied as a tag, a legible tattoo, electronic device, or any other device approved by APHIS. The Idaho Premises/Flock Identification number can serve as the official individual identification number if it contains a unique individual animal number in addition to the Idaho premises/flock identification number. (3-23-23)

~~23. **Post-Exposure Monitoring and Management Plan.** A monitoring plan which includes a written agreement signed by the owner of the flock and a representative of the Division of Animal Industries and an APHIS representative in which each participant agrees to undertake actions specified in the agreement to monitor for the occurrence of scrapie in the flock for at least five (5) years after an approved Flock Plan has been completed. The PEMMP requires at least once a year flock inspections and prompt reporting of any animal over fourteen (14) months of age which dies in the flock so that some of these animals can be selected and submitted for scrapie testing. The Plan also includes the requirements outlined in 9 CFR Part 54.8. Owners may request to join the Scrapie Flock Certification Program after two (2) years of participation in the PEMMP. (3-23-23)~~

2418. Premises. The ground, area, buildings and equipment utilized to raise, propagate or control sheep and goats. (3-23-23)

2519. Quarantine. A written order, executed by the Board or the Administrator of Animal Industries, to confine or hold animals on a premises or any other location, where found, and prevent movement of animals from a premises or any other location. (3-23-23)

260. Scrapie. A transmissible spongiform encephalopathy that is a nonfebrile, transmissible, insidious, degenerative disease affecting the central nervous system of sheep and goats. (3-23-23)

~~27. **Scrapie Exposed Animal.** Any animal which has been in the same flock at the same time within the previous seventy two (72) months as a scrapie positive female animal excluding limited contacts. Limited contacts are contacts between animals that occur off the premises of the flock and do not occur during or within sixty (60) days after parturition for any of the animals involved. (3-23-23)~~

~~28. **Scrapie Flock Certification Program.** A cooperative Federal-State-Industry voluntary program for reducing the incidence and controlling the spread of scrapie through flock certification. (3-23-23)~~

29. Scrapie High Risk Animal. An animal determined by epidemiologic investigation to face a high

- ~~risk of developing clinical scrapie because the animal was: (3-23-23)~~
- ~~a. Progeny of a scrapie positive dam; (3-23-23)~~
 - ~~b. Born in the same contemporary lambing group as a scrapie positive animal, or (3-23-23)~~
 - ~~c. During any subsequent lambing season if born before the flock completes the requirements of a flock plan; or (3-23-23)~~
 - ~~d. Born in the same contemporary lambing group as progeny of a scrapie positive dam or any QQ, at codon 171, sheep present in the lambing facility/area where a scrapie positive animal was born during the contemporary birth of a scrapie positive animal. (3-23-23)~~
 - ~~e. Animals that fit the criteria for high risk animals which are determined by genetic testing to be QR or RR at the 171 codon, or are determined by other recognized testing procedures to pose no risk, may be exempted as high risk animals by the Board, upon the recommendation of the State Scrapie Certification Board, based upon evidence from the latest research information available. (3-23-23)~~
- ~~30. **Scrapie Infected Flock.** Any flock in which a scrapie positive animal has been born, birthed or aborted. A flock will no longer be considered infected after an approved Flock Plan has been completed. (3-23-23)~~
- ~~31. **Scrapie Positive Animal.** An animal for which a diagnosis of scrapie has been made by the National Veterinary Services Laboratories, or another laboratory authorized by state or federal officials to conduct scrapie tests approved for scrapie diagnosis by APHIS or the Administrator. (3-23-23)~~
- ~~32. **Scrapie Source Flock.** A flock in which an animal was born and subsequently diagnosed as scrapie positive at less than seventy-two (72) months of age. The flock will no longer be considered a source flock after the requirements of an approved Flock Plan have been completed. A trace to a flock must meet the following criteria to designate the flock as a source flock: The scrapie positive animal must: (3-23-23)~~
- ~~a. Be identified with a Premises/Flock Identification Number, or on an official ear tag, electronic device, ear tattoo, or flank tattoo which is correlated to the Premises/Flock Identification number on flock records; or (3-23-23)~~
 - ~~b. Be identified with a genetic heredity test or nose print; or (3-23-23)~~
 - ~~c. Possess the original registry ear tag or individual identification ear tag along with the movement, production, or registry records indicating birth in the source flock; or (3-23-23)~~
 - ~~d. Be traced to the flock by a veterinary epidemiologist through a thorough epidemiological investigation of records and all other available evidence. (3-23-23)~~
- ~~3321. **State Animal Health Official.** The Administrator, or his designee, responsible for disease control and eradication programs. (3-23-23)~~
- ~~3422. **State Scrapie Certification Board.** The State Scrapie Certification Board will consist of APHIS-AVIC, the State animal health official, animal producers and accredited veterinarians. Animal producers and accredited veterinarians will be appointed by the AVIC and the State animal health official. (3-23-23)~~
- ~~35. **Terminal Feedlot.** As defined in Title 9 CFR, Parts 54 and 79. (3-23-23)~~
- ~~3623. **Trace.** All actions required to identify the flock of origin or destination of an animal. (3-23-23)~~
- 011. ABBREVIATIONS.**
- 01. APHIS.** Animal Plant Health Inspection Service. (3-23-23)

- 02. AVIC. Area Veterinarian in Charge. (3-23-23)
- 03. CFR. Code of Federal Regulations. (3-23-23)
- 04. PEMMP. Post Exposure Monitoring and Management Plan. (3-23-23)
- 05. USDA. United States Department of Agriculture. (3-23-23)
- 06. VS. Veterinary Services. (3-23-23)

012. APPLICABILITY.

These rules apply to all domestic sheep and goats located in, imported into, exported from, or transported through the state of Idaho. (3-23-23)

013. ADDITIONAL IMPORT REQUIREMENTS.

The Board may impose additional or more restrictive import requirements than the requirements in this chapter by issuing a written order stating the additional requirements and the reasons for the requirements. (3-23-23)

014. -- 099. (RESERVED)

100. SHEEP AND GOAT STATE ENTRANCE REQUIREMENTS.

01. Entrance Requirements. All breeding sheep and goat stock entering the state of Idaho except as provided in Sections 103, 105, and 107 of these rules will be accompanied by a permit or approved eCVI issued by the Board together with a certificate of veterinary inspection certifying that such sheep or goats are free from scrapie, scabies, foot rot, brucella or symptoms of any communicable disease and are not known to have been exposed to scrapie for at least seventy-two (72) months prior to the date of inspection, scabies for a period of at least six (6) months immediately prior to date of inspection and are not known to have been exposed to any communicable disease for at least thirty (30) days immediately prior to date of inspection. All breeding sheep and goats with the exception of low-risk commercial goats imported into the state of Idaho must be individually identified with an official premises/flock identification number, or legible tattoo or other form of individual identification approved by the Board. The premises/flock identification number must be listed on the certificate of veterinary inspection. The original or true copy of the permit and certificate of veterinary inspection required by this rule will be attached to the waybill covering such shipments. No sheep will be shipped, trailed, or in any manner moved into the state of Idaho for any purpose if they originate in a state or area where sheep scabies is known to exist until the Board has been notified by the APHIS that such state or area where sheep scabies is known to exist has been classified by the APHIS as a sheep scabies eradication area. (3-23-23)()

02. Brucella Ovis. Intact male sheep six (6) months of age or older must test negative for Brucella Ovis within thirty (30) days prior to entry. Rams entering for exhibition only and returning to the state of origin are exempt from testing. Rams imported from a state certified *Brucella Ovis* free flock are also exempt. (3-23-23)

101. PERMITS.

01. Request for Permits. ~~Request for the permits required under Section 100 are to be in writing, by telephone or facsimile and set forth the name and address of the owner of the animals offered for movement into the state of Idaho, the number and class of sheep and goats to be brought in, the destination, the name and address of the consignee, and the approximate date and place of entry. A copy of the permit, or permit number written on the face of the waybill or certificate of veterinary inspection accompanying movement, will be shown to a representative of the Board or any law enforcement officer of the state, county, or municipality of the state of Idaho upon request.~~ Request for permits to import sheep and goats, when applicable, into the state of Idaho shall be directed to the Division of Animal Industries online Import Permit System at <https://www.isda.idaho.gov/AnimalImport/> or by telephone (208) 803-5084. (3-23-23)()

02. Certificates of Veterinary Inspection to Be Furnished. Copies of the certificates of veterinary inspection from the point of origin must accompany the shipment and include a copy of the permit or the permit number written on the face of the certificate of veterinary inspection and will be shown to a representative of the

Board or any law enforcement officer of the state, county, or municipality of the state of Idaho upon request, and a copy forwarded to the Idaho Department of Agriculture, Division of Animal Industries, c/o Idaho Sheep and Goat Health Board, P.O. Box 7249, Boise, Idaho 83707, immediately after issuance for sheep and goats entering the state of Idaho. (3-23-23)

03. Inspection Fees. An inspection fee of one hundred dollars (\$100) per incidence, plus mileage, will be paid on all sheep and goats exported from or imported into Idaho in violation of these rules. Such incidences require an inspection of animals, certificates of veterinary inspection and permit. (3-23-23)

04. Examination and Treatment Fees. The Board may assess a fee on sheep and goat producers who receive services from the Board or its representatives, such as examination and treatment of animals for diseases or parasites. The fees assessed are not to exceed the actual costs for the services rendered. (3-23-23)

102. SCABIES.

All sheep and goats, including rams and bucks, entering Idaho and which have originated in an area or areas in which scabies is known to exist within the past six (6) months must be treated with a product approved by the APHIS under the supervision of an authorized state or federal inspector or accredited veterinarian. At the time of shipment, such sheep or goats must be accompanied by a permit from the Board and a certificate of veterinary inspection from the state of origin and also a treatment certificate showing that such sheep or goats have been treated at point of origin as herein required. Any and all shipments of sheep and goats entering Idaho, and which have originated in states where scabies is known to exist, are subject to a thirty (30) to sixty (60) day quarantine and inspection at the time of arrival at destination, and a second inspection at the time of quarantine release, or as often as it may be deemed necessary by the Board. (3-23-23)

103. ANIMALS IN TRANSIT.

Sheep and goats in course of transit through the state of Idaho, in trucks, or other vehicles from a point outside the state of Idaho to another state or country, are not to be unloaded in Idaho except in pens designated by APHIS for purpose of feed, water and rest for a period of time not to exceed ten (10) days, need not comply with Section 100, provided waybills or other documents accompanying the sheep or goats show origin and destination of such sheep and goats. Failure to have such waybills or other documents with the sheep or goats constitutes a violation of these rules. The Board, however, may prohibit the transportation of any sheep or goats through the state it feels represents a threat to the general health and welfare of the Idaho sheep industry. (3-23-23)

104. DAIRY GOATS.

All dairy type goats, including bucks, entering the state of Idaho must be accompanied by a permit issued by the Board, together with a certificate of veterinary inspection issued at point of origin by an authorized veterinarian. All dairy type goats, including bucks, aged six (6) months or older must have been tested negative for *Brucella Melitensis* within thirty (30) days of the date of entry into the state of Idaho accompanied by the negative test chart signed by the person in charge of the laboratory where the test was made and approved by the state animal health official of the state of origin and attached to the certificate of veterinary inspection. Goats entering Idaho on a short-term temporary basis for show or other temporary purposes may be exempted from having a negative test for *Brucella Melitensis* completed, with permission from the Board. (3-23-23)

105. IMPORTATION OF SCRAPIE EXPOSED, SUSPECT AND HIGH RISK ANIMALS.

Sheep and goats that are scrapie suspect, exposed, or high risk animals or from scrapie infected, source, or exposed flocks, as defined Title 9, Parts 54.1 and 79.1, Code of Federal Regulations, are not allowed entry into Idaho except as follows: (3-23-23)

01. Valid Permit. Scrapie suspect, exposed or high-risk animals and animals from infected, source or exposed flocks may be imported directly to scrapie research facilities, or to approved slaughter establishments for immediate slaughter, or other destinations approved by the Administrator, if accompanied by a permit issued by the Board or its representative; and (3-23-23)

02. Officially Identified. The animals are individually identified by official identification tattoos, tags, or devices on a VS 1-27 or other approved movement document. (3-23-23)

106. IDAHO ORIGIN SHEEP INTERSTATE GRAZING PERMIT.

Idaho origin, low-risk commercial sheep breeding stock with no history of scrapie exposure returning to Idaho from seasonal grazing in other states may return to Idaho without a certificate of veterinary inspection if they are accompanied by an Idaho Origin Sheep Interstate Grazing Permit and a waybill. The Idaho Origin Sheep Interstate Grazing Permit is to be obtained from the Board. (3-23-23)

107. INTERSTATE SHIPMENTS.

01. Waybill Requirement. All sheep and goats leaving the state of Idaho by any common carrier, by private conveyance, or any kind of transportation must be accompanied by a waybill, stating the owner's name and indicating destination of sheep or goats, or be accompanied by a certificate of veterinary inspection issued by an inspector appointed by the Board or a representative of the APHIS or accredited veterinarian; said certificates of veterinary inspection to be dated not more than thirty (30) days prior to date of movement, and comply with the rules for the state of destination. (3-23-23)

02. Waybill Violation. Failure to have such waybills or other documents accompanying the sheep or goats constitutes a violation of these rules and is punishable as provided in Section 900. (3-23-23)

03. Carriers. No common or contract carrier or owner or caretaker will unload any breeding sheep, breeding goats, or dairy goats within the state of Idaho from other states or country, other than as provided in Sections 103, 105, 106, and 107, of these rules, unless such shipments be accompanied by an Idaho Origin Sheep Interstate Grazing Permit issued by the Board or other permit issued by the Board, and the official certificate as provided herein. The original or true copy of each certificate with permit must be attached to the waybill covering such shipments or be in possession of the owner or caretaker of shipment. (3-23-23)

04. Who May Inspect? Authorized state or federal inspectors and accredited veterinarians may inspect sheep and goats. (3-23-23)

108. -- 199. (RESERVED)

~~**200. SCRAPIE PROGRAM STANDARDS, SCRAPIE FLOCK CERTIFICATION, SCRAPIE CONTROL AND ERADICATION.**~~

~~The Board adopts the provisions of the Voluntary Scrapie Flock Certification Program Standards, which were effective June 2013, and 9 CFR, Parts 54.1, 54.2, 54.8, 54.9, 54.10, 54.11, 54.20, 54.21, 54.22 and 79, January 1, 2015, as the minimum standards for the scrapie certification program in Idaho. (3-23-23)~~

2040. IDENTIFICATION OF BREEDING SHEEP AND GOATS.

01. Assignment of APHIS Approved Idaho Premises/Flock Identification Numbers. The Board or its designee will assign APHIS-approved Idaho premises/flock identification numbers with unique individual animal identification numbers to Idaho sheep and goat flocks/herds. (3-23-23)

02. Responsibility for Identification. Owners and possessors of breeding sheep and goats bear the cost and responsibility of obtaining the identification devices and placing the device in or on the animal. (3-23-23)

03. Time of Identification. All owners or possessors of breeding sheep and goats in Idaho will identify all breeding stock in the flock of any age with a premises/flock identification number before transfer of ownership or possession, show, sale, or other movement unless the animals are under eighteen (18) months of age and are in slaughter channels. (3-23-23)

04. Importation Identification. Breeding sheep or goats imported into the state must be identified with a premises/flock identification number before entry into the state. (3-23-23)

05. Loss of Identification. Breeding sheep or goats sold within the state retain the original premises/flock identification number. In the event an animal loses a premises/flock identification device, the owner of the animal will re-identify the animal with his or her flock identification number and maintain records to document the original and new flock identification numbers. (3-23-23)

06. Acceptable Identification. Acceptable devices for application of the premises/flock identification number to breeding sheep and goats include: APHIS-approved ear tags bearing the premises/flock identification number, legible tattoos bearing the premises/flock identification number, approved Scrapie Flock Certification Program identification devices, except electronic identification, and other identification devices approved by APHIS except electronic identification. (3-23-23)

07. Identification Exemption. Animals exempt from the requirement for identification with a premises/flock identification number include: (3-23-23)

- a.** Neutered animals under eighteen (18) months of age. (3-23-23)
- b.** Sexually intact market lambs under eighteen (18) months of age shipped directly to an approved slaughter establishment or shipped directly to a feedlot for finish feeding for slaughter only. (3-23-23)
- c.** Animals which have not been removed from their premises of origin and/or transferred ownership with the exception of white-face low-risk range sheep as defined in the 9 CFR Part 79 which are moved for grazing or other management purposes and do not change ownership. (3-23-23)
- d.** Castrated or low-risk commercial goats. (3-23-23)
- e.** Registered sheep and goats accompanied by registration papers or a certificate of veterinary inspection with legible unique registration tattoos. (3-23-23)
- f.** Goats registered with a National Goat Registry that allows for electronic implant identification, as recorded on a registration certificate, may be identified with an electronic implant. (3-23-23)

2021. QUARANTINE.

Infected and source flocks or flocks that have received high-risk animals will be placed and held under quarantine until the infected or high-risk animals have been slaughtered or depopulated, an approved Flock Plan has been completed and the flock is participating in a Post Exposure Monitoring Program. Flocks that do not participate in a Post Exposure Monitoring Program remain under quarantine until the entire flock has been depopulated. Flocks which are removed from the Post Exposure Monitoring Program before the agreed time will be re-quarantined. (3-23-23)

2032. RESTRICTION OF HIGH-RISK ANIMALS.

High-risk animals will be placed under a quarantine when the flock or animals are determined to be exposed. An epidemiological investigation will be conducted on the flock or animals to determine the risk of infection with scrapie. The flock or animals will be maintained under quarantine until the flock is in compliance with the Scrapie Uniform Methods and Rules in effect or until the scrapie epidemiologist has determined that the flock or animals do not pose a substantial risk to other flocks. (3-23-23)

2043. MOVEMENT OF RESTRICTED ANIMALS.

Animals from infected and source flocks and high-risk animals may be moved from quarantined premises only under the following conditions: (3-23-23)

- 01. Individually Identified on Approved Document.** The animals are individually identified on a VS 1-27 form or other approved document, by official ear tags, tattoos or devices; or (3-23-23)
- 02. Indelibly Marked.** The animals are indelibly marked with an “S” at least one (1) inch high on the left jaw; and (3-23-23)
- 03. Consigned Directly to Approved Destination.** The animals are consigned directly to an approved slaughter facility for immediate slaughter or to a terminal feedlot for finish feeding for slaughter only; or (3-23-23)
 - a.** The animals are consigned directly to an approved livestock market for sale directly to an approved slaughter facility for immediate slaughter or to a feedlot for finish feeding for slaughter only. The animals must be individually identified on a VS 1-27 form or other approved document for movement from the approved livestock

market to final destination; or (3-23-23)

b. The Board or its representative may, by written permission, allow the animals to be moved, under quarantine, to other pre-approved locations. The animals may be moved in sealed vehicles or be accompanied in transit by representatives of the Board in lieu of individual identification. Animals so moved will be retained under quarantine at the new location. (3-23-23)

2054. -- 399. (RESERVED)

400. CONDEMNATION AND DESTRUCTION OF DISEASED ANIMALS OR FLOCKS.

01. Animals or Flocks Infected. Animals or flocks determined by representatives of the Board or APHIS to be infected with scrapie or other contagious, infectious, or communicable diseases which have been identified by the Board to be diseases of concern to human health or the livestock industry of the state may be condemned by order of the Board. (3-23-23)

02. Animals or Flocks Condemned. Animals or flocks condemned by order of the Board will be destroyed or otherwise disposed of as directed by order of the Board and under the conditions set by the Board. (3-23-23)

401. -- 499. (RESERVED)

500. INDEMNIFICATION.

01. Owners, Individuals, Partnerships, Corporations or Other Legal Entities. Owners, individuals, partnerships, corporations or other legal entities whose animals or flocks have been destroyed or otherwise disposed of by order of the Board may be eligible for indemnification in the form of cash payment from the Sheep and Goat Disease Indemnity Fund for all or part of the value of the animals destroyed or otherwise disposed of and for the actual cost for burial or disposal of animal carcasses. (3-23-23)

02. Indemnity Payments Paid. Indemnity payments are paid only to an owner of sheep or goats that were born in the state of Idaho or were imported into the state in compliance with existing Idaho statutes and rules promulgated thereunder. (3-23-23)

03. Amount of Indemnity to Be Paid for Each Animal. The amount of indemnity to be paid for each animal is determined by the Board and does not exceed the difference between the appraised price, less federal indemnity, and the salvage value of the animal. In the event federal indemnity is not available the amount of indemnity will not exceed the difference between the appraised price and salvage value. (3-23-23)

04. Appraisals. Appraisals are to be performed by a team comprised of an Animal Health representative, the owner, and a person with experience in sheep or goat marketing. (3-23-23)

05. Maximum Amount of Indemnity. The maximum amount of indemnity for each animal will not exceed: (3-23-23)

a. Ewes or does one (1) year of age or older - two hundred dollars (\$200) per head. (3-23-23)

b. Rams or bucks one (1) year of age or older - four hundred dollars (\$400) per head. (3-23-23)

c. Lambs or kids under one (1) year of age - current market price per pound with a maximum of one hundred dollars (\$100) per head. (3-23-23)

06. Indemnity Payment upon Approval of Appraisal. Upon approval of the appraisal by the Board, one-half (1/2) of the indemnity payment will be paid at that time. The other one-half (1/2) of the indemnity payment, or the prorated portion thereof, will be paid at the end of the fiscal year. Indemnity payments are paid in their entirety in a single fiscal year and do not exceed the amount in the fund. (3-23-23)

501. -- 599. (RESERVED)

600. CLEANING AND DISINFECTION.

Barns, sheds, stockyards, trucks, aircraft, ferryboats and other vehicles, feed yards, stables, pens, corrals, lanes and premises that have been used in confining, trailing, or transporting any sheep or goats affected or infected with any contagious, infectious or communicable diseases, will be cleaned and disinfected under state or federal supervision as directed by the Board, or an authorized representative of the Board, and the owner of such premises, conveyances, or carrier are responsible for such cleaning and disinfecting. (3-23-23)

601. -- 699. (RESERVED)

700. SHEEP ASSESSMENTS.

The following rules apply to all sheep. (3-23-23)

01. Payment of Assessment. The owner of sheep on July 1st of the assessment year is responsible for the payment of the assessment levied by the Boards as provided for in Section 25-130 and 25-131, Idaho Code. The rate of assessment is eight cents (\$.08) per pound on all wool, in the grease basis, except tags, crutchings, and dead wool. (3-23-23)

02. Assessment as Resident Sheep. The assessment is levied and assessed to the producer at the time of the first sale of wool and is deducted by the first purchaser from the price paid to the producer at the time of such sale. (3-23-23)

03. Migratory Sheep. In the event that a sheep, which produces wool subject to this assessment, is located outside the state of Idaho during a part of the assessment year, the amount of the assessment is reduced on a prorated basis. A grower will be required to request a prorated adjustment in writing to the Board. (3-23-23)

04. Costs of Collection. All costs of collection of delinquent assessments are borne as an additional charge against the delinquent assessee first purchaser. (3-23-23)

701. GOAT ASSESSMENTS.

The following rules apply to all goats. (3-23-23)

01. Payment of Assessment. The owner of goat(s) is responsible for the payment of the assessment levied by the Board as provided for in Sections 25-130 and 25-131, Idaho Code. The rate of assessment is eighty cents (\$.80) per head. (3-23-23)

02. Assessment as Resident Goats. The assessment is levied and assessed to the producer at the time of the sale of said goat(s). (3-23-23)

a. Auction Yards: Auction yards will deduct the assessment from the price paid to the producer at the time of sale. All goat assessments will be sent to the Idaho Sheep and Goat Health Board (ISGHB) from the auction yards after each sale, but no later than thirty (30) days after the sale. Assessments will be accompanied by a board approved form that includes a list of the producers (sellers) name, address, and number of head sold. (3-23-23)

b. Private Sales: The producer will handle assessment on private sales. The producer will send at minimum an annual assessment to the ISGHB on all private sales no later than the end of December of the current year. (3-23-23)

03. Costs of Collection. All costs of collection of delinquent assessments are borne as an additional charge against the delinquent assessee. (3-23-23)

~~**702. -- 899. (RESERVED)**~~

~~**900. VIOLATIONS.**~~

~~Any person, company, corporation or association, or any agent, servant or employee of such, who violates or disregard any of these sheep and goat rules or any other sanitary or quarantine rule, order of the Board or inspector~~

~~thereof, is deemed guilty of a misdemeanor and upon conviction be fined not less than one hundred dollars (\$100) nor more than five thousand dollars (\$5,000) for each offense.~~ (3-23-23)

~~901~~**702**. -- 999. (RESERVED)

IDAPA 08 – STATE BOARD OF EDUCATION

08.01.13 – RULES GOVERNING THE OPPORTUNITY SCHOLARSHIP PROGRAM

DOCKET NO. 08-0113-2401

NOTICE OF RULEMAKING – PROPOSED RULE

AUTHORITY: In compliance with Section 67-5221(1), Idaho Code, notice is hereby given that this agency has initiated proposed rulemaking procedures. The action is authorized pursuant to Article IX, Section 2, Idaho Constitution and under Sections 33-105, 33-4303, and 33-4304, Idaho Code.

PUBLIC HEARING SCHEDULE: Public hearing(s) concerning this rulemaking will be scheduled if requested in writing by twenty-five (25) persons, a political subdivision, or an agency, not later than October 16, 2024.

The hearing site(s) will be accessible to persons with disabilities. Requests for accommodation must be made not later than five (5) days prior to the hearing, to the agency address below.

DESCRIPTIVE SUMMARY: The following is a nontechnical explanation of the substance and purpose of the proposed rulemaking:

H500 and H747 (2024) amended Idaho Code § 33-4303. To remain compliant with the governing statute, IDAPA 08.01.13 must be revised to reflect several key changes. These changes include the following: updating the credit completion minimums for students seeking to renew an Opportunity Scholarship beyond the initial year of award; including a new initial eligibility requirement that restricts students from receiving both the Opportunity Scholarship and the Launch Grant simultaneously; and reinstating community colleges as eligible recipients of Opportunity Scholarship Funds.

FEE SUMMARY: The following is a specific description of the fee or charge imposed or increased: NA

FISCAL IMPACT: The following is a specific description, if applicable, of any negative fiscal impact on the state General Fund greater than ten thousand dollars (\$10,000) during the fiscal year resulting from this rulemaking: NA

NEGOTIATED RULEMAKING: Pursuant to Section 67-5220(1), Idaho Code, negotiated rulemaking was conducted. The Notice of Intent to Promulgate Rules - Negotiated Rulemaking was published in the June 5, 2024 Idaho Administrative Bulletin, [Volume 24-6, page 14](#).

INCORPORATION BY REFERENCE: Pursuant to Section 67-5229(2)(a), Idaho Code, the following is a brief synopsis of why the materials cited are being incorporated by reference into this rule: NA

ASSISTANCE ON TECHNICAL QUESTIONS, SUBMISSION OF WRITTEN COMMENTS: For assistance on technical questions concerning the proposed rule, contact Nicholas Wagner at rules@edu.idaho.gov or (208)488-7586.

Anyone may submit written comments regarding this proposed rulemaking. All written comments must be directed to the undersigned and must be delivered on or before October 23, 2024.

DATED this 23rd day of August, 2024.

Nicholas Wagner
Administrative Rules Coordinator
Idaho State Board of Education
650 W State St.
PO Box 83720
Boise, Idaho 83720-0037
Phone: (208)488-7586, fax: (208)334-2632

THE FOLLOWING IS THE PROPOSED TEXT OF DOCKET NO. 08-0113-2401
(Only Those Sections With Amendments Are Shown.)

08.01.13 – RULES GOVERNING THE OPPORTUNITY SCHOLARSHIP PROGRAM

101. ELIGIBILITY.

01. Academic Eligibility. To be eligible for an opportunity scholarship, an applicant must meet minimum academic eligibility criteria, as follows: (4-6-23)

a. A student who has not yet graduated from an eligible secondary school or its equivalent in the state of Idaho must have an unweighted minimum cumulative grade point of average of two point seven (2.7) or better on a scale of four point zero (4.0) to be eligible to apply for an opportunity scholarship. Cumulative grade point averages of more than one (1) decimal place shall be rounded to one (1) place. Home schooled students must provide a transcript of subjects taught and grades received signed by the parent or guardian of the student; or (4-6-23)

b. A student who has obtained a general equivalency diploma must have taken the ACT assessment and received a minimum composite score of twenty (20) or better, or the equivalent SAT assessment and received a one thousand ten (1,010) or better, to be academically eligible to apply for an opportunity scholarship; or (4-6-23)

c. A student currently enrolled in an eligible Idaho postsecondary educational institution must have a minimum cumulative grade point average of two point seven (2.7) or better on a scale of four point zero (4.0) at such institution in order to be academically eligible to apply for an opportunity scholarship. Cumulative grade point averages of more than one (1) decimal place shall be rounded to one (1) place. (4-6-23)

d. An Adult Learner must have a minimum cumulative grade point average of two point five (2.5) or higher on a scale of four point zero (4.0). Cumulative grade point averages of more than one (1) decimal place shall be rounded to one (1) decimal place. (4-6-23)

02. Financial Eligibility. The financial need of an applicant for an opportunity scholarship will be based upon the Student Aid Index, as identified by the free application for federal student aid (FAFSA) Submission Summary. (7-1-24)()

03. Additional Eligibility Requirements. (4-6-23)

a. A student must not be in default on a student educational loan, or owe a repayment on a federal grant, and must be in good financial standing with the opportunity scholarship program. (4-6-23)

b. If a student has attempted or completed more than one hundred and twenty (120) postsecondary credits, then such student must identify a major, the required number of credits necessary for graduation in such major, and shall submit an academic transcript that contains all courses taken and all postsecondary credit received to the Board office. A student shall not be eligible for an opportunity scholarship if: (4-6-23)

i. The student has completed more than one hundred fifty percent (150%) of the courses and academic credit necessary to graduate in such major; or (4-6-23)

ii. Upon review of the student's academic transcript(s), the student cannot complete a degree/certificate in the major identified within two (2) semesters based on normal academic course load unless a determination by the executive director or designee has been made that there are extenuating circumstances and the student has a plan approved by the executive director or designee outlining the courses that will be taken and the completion date of the degree or certificate. (4-6-23)

102. -- 201. (RESERVED)

202. APPLICATION PROCESS.

01. Applications. An eligible student must complete and submit the opportunity scholarship program application to the Board electronically on or before the deadline set by the executive director each year. Adult Learner applications will be processed and awarded on a monthly basis up to the application deadline. An applicant without electronic capabilities may request a waiver of this requirement and, if granted, submit an application on the form established by the Board through the United States Postal Service that must be postmarked not later than the applicable application deadline. The FAFSA must be completed on or prior to the application deadline unless federal delays prohibit an applicant from completing the FAFSA prior to the deadline. (7-1-24)

02. Announcement of Award. Announcement of the award of initial scholarships will be made no later than ~~December 31~~ June 1 of each year, with awards to be effective at the beginning of the first full term of the next fiscal year. Announcements must clearly state the award is part of the state's scholarship program and is funded through state appropriated funds. Additional award announcements may be made after this date based on the availability of funds. (7-1-24)()

03. Communication with State Officials. Applicants must respond by the date specified to any communication from officials of the opportunity scholarship program. Failure to respond within the time period specified will result in cancellation of the scholarship unless extenuating circumstances are involved and approved by the executive director or designee. (4-6-23)

203. -- 299. (RESERVED)

300. SELECTION OF SCHOLARSHIP RECIPIENTS.

01. Selection Process. Scholarship awards will be based on the availability of scholarship program funds. Opportunity scholarships will be awarded to applicants, based on ranking and priority, in accordance with the following criteria: (4-6-23)

a. Eligible students shall be selected based on ranking criteria that assigns seventy percent (70%) to financial eligibility, and thirty percent (30%) to academic eligibility. In the event that this weighted score results in a tie, an eligible student who submitted an application to the Board earlier in time will be assigned a higher rank. (4-6-23)

b. Notwithstanding Subsection 300.01.a. of these rules, the priority for the selection of recipients of opportunity scholarship awards shall be to scholarship recipients who received an opportunity scholarship award during the previous fiscal year, and have met all of the continuing eligibility requirements provided in these rules. (4-6-23)

02. Monetary Value of the Opportunity Scholarship. (4-6-23)

a. The monetary value of the opportunity scholarship award to a student shall be based on the educational costs for attending an eligible Idaho postsecondary educational institution, less the following: (4-6-23)

i. The amount of the assigned student responsibility, established by the Board annually; (4-6-23)

ii. The amount of federal grant aid, as identified by the FAFSA Submission Summary if known at the time of award determination; (7-1-24)

iii. The amount of other financial aid awarded the student, from private or other sources that is known at the time of award determination. (4-6-23)

iv. The eligible maximum award amount for Adult Learners enrolled in less than twenty-four (24) credit hours along with the requirements outlined in Subsection 302.01, or its equivalent in an academic year will be prorated as follows: (7-1-24)()

(1) Enrolled in six (6) to eight (8) credits or its equivalent per term - fifty percent (50%) of the maximum; (4-6-23)

(2) Enrolled in nine (9) to eleven (11) credits or its equivalent per term - seventy-five percent (75%) of the maximum; and (4-6-23)

(3) Enrolled in twelve (12) or more credits or its equivalent per term - one hundred percent (100%) of the maximum. (4-6-23)

b. The amount of an opportunity scholarship award to an individual student shall not exceed the actual cost of tuition and fees at the institution the student attends or will attend, or if the student attends or will attend an Idaho private postsecondary educational institution, the average tuition at Idaho's public four (4) year postsecondary educational institutions. (4-6-23)

c. The Board may determine monetary value without the FAFSA Submission Summary if the delay is due only to federal delay and may modify any final award or payment upon receipt of the FAFSA Submission Summary. (7-1-24)

301. OPPORTUNITY SCHOLARSHIP AWARD.

01. Payment. Payment of opportunity scholarship awards will be made in the name of the recipient and will be sent to a designated official at the eligible Idaho postsecondary educational institution in which the recipient is enrolled. The official must transmit the payment to the recipient within a reasonable time following receipt of the payment. (4-6-23)

02. Duration. Scholarships will be awarded on an annual basis and payments will correspond to academic terms, semesters, quarters, or equivalent units. In no instance will the entire amount of a scholarship be paid in advance to, or on behalf of, a scholarship recipient. The scholarship may cover up to four (4) educational years, or eight (8) semesters or equivalent for attendance at an eligible Idaho postsecondary educational institution. Awards are contingent on annual appropriations by the legislature and continued eligibility of the student. (4-6-23)

03. Eligibility. If a student receives an opportunity scholarship payment and it is later determined that the student did not meet all of the Opportunity Scholarship Program eligibility requirements, then the student is considered in overpayment status, and must return program funds in accordance with the eligible Idaho postsecondary educational institution's refund policy. (4-6-23)

~~**04. New Scholarships for Community College.** The Board may not award any new scholarship, excluding renewals, to any student attending community college on or after July 1, 2023. (7-1-24)~~

302. CONTINUING ELIGIBILITY.

~~**01. Credit Hours Requirements.** To remain eligible for renewal of an opportunity scholarship, the scholarship recipient attending a four (4) year eligible postsecondary institution must have completed a minimum of twenty four (24) credit hours or its equivalent each academic year that the student received an opportunity scholarship award and the scholarship recipient attending a two (2) year public postsecondary institution who accepted an award offer or renewed an award offer on or before June 30, 2023, must have completed a minimum of eighteen (18) credit hours or its equivalent each academic year that the student received an opportunity scholarship award. Notwithstanding these provisions, a scholarship recipient who has received the Opportunity Scholarship as an Adult Learner may retain eligibility by completing twelve (12) or more credit hours or its equivalent each academic year the student received the Opportunity Scholarship award. For an eligible student that has previously received an opportunity scholarship award to renew such award for the next year, the eligible student shall maintain progress towards on-time degree completion so that such student is on schedule to obtain an associate degree within two (2) years or a baccalaureate degree within four (4) years from the time such student initially received an opportunity scholarship award. All students may use the summer term to meet the annual credit accumulation requirements. (7-1-24)()~~

02. Renewal Application. In order to be considered for a continuing scholarship for each succeeding year, a scholarship recipient must complete a renewal application by March 1. ()

023. Academic Progress. To remain eligible for renewal of an opportunity scholarship, the scholarship recipient must have maintained a minimum cumulative grade point average of two point seven (2.7) on a scale of four point zero (4.0), and must be maintaining satisfactory academic progress toward their identified postsecondary credential as determined by the institution they are enrolled in. Students receiving an Opportunity Scholarship award as an Adult Learner must make satisfactory progress on their graduation plan established with the eligible institution at the time of admission. (4-6-23)

034. Eligibility Following Interruption of Continuous Enrollment. A scholarship recipient whose continuous enrollment is interrupted for more than four (4) months but less than two (2) years for any reason but who intends to re-enroll in an eligible Idaho postsecondary educational institution must file a letter of intent to withdraw no later than thirty (30) days prior to the first day of the academic term of the discontinued attendance to the Office of the State Board of Education. Failure to do so may result in forfeiture of the scholarship. The Board's Executive Director or designee will review each request for interruption and notify the individual of approval or denial of the request. In addition, the individual must file a statement with the Board declaring intent to re-enroll as a full-time undergraduate student in an academic or career technical program in an eligible Idaho postsecondary educational institution for the succeeding academic year no later than thirty (30) days prior to the first day of the academic term in which the individual intends to re-enroll within two (2) years of the approval of the request to withdraw. Failure to do so will result in forfeiture of the scholarship unless an extension has been granted. An extension of interruption of continuous enrollment period may be granted for eligible students due to military service in the United States armed forces, medical circumstances, or other circumstances approved by the executive director. All requests for extension must be made thirty (30) days prior to the start of the succeeding academic year. (4-6-23)

303. -- 399. (RESERVED)

400. RESPONSIBILITIES OF ELIGIBLE IDAHO POSTSECONDARY EDUCATIONAL INSTITUTIONS.

01. Statements of Continuing Eligibility. An eligible Idaho postsecondary educational institution participating in this Opportunity Scholarship Program must submit statements of continuing student eligibility to the Board by the 30th day after the end of the spring semester or equivalent term. Such statements must include verification that the scholarship recipient is still enrolled, ~~attending part-time, if an Adult Learner, and full-time for all other scholarship recipients, maintaining satisfactory academic progress,~~ is meeting the continued eligibility requirements as described in Section 302.01, and has not exceeded the award eligibility terms. (4-6-23)()

02. Other Requirements. An eligible Idaho postsecondary educational institution must: (4-6-23)

a. Be eligible to participate in Federal Title IV financial aid programs, and must supply documentation to the Board verifying this eligibility, and prompt notification regarding any changes in this status; (4-6-23)

b. Have the necessary administrative computing capability to administer the Opportunity Scholarship Program on its campus, and electronically report student data records to the Board; (4-6-23)

c. Provide data on student enrollment and federal, state, and private financial aid for students to the Board within set timelines, and (4-6-23)

d. Agree to permit periodic Opportunity Scholarship Program audits to verify compliance with Idaho law and these rules related to the program. (4-6-23)

03. Adult Learner Evaluation. ~~Upon admission, scholarship recipients receiving an award as an Adult Learner will be administered prior learning assessments to determine eligibility for credit for prior learning, including credit for prior experiential learning. As a part of this the adult learner evaluation process is that~~ an eligible institution will work with the student to develop a graduation plan for the program they are entering that includes estimated completion dates. (4-6-23)()

IDAPA 08 – STATE BOARD OF EDUCATION

08.02.02 – RULES GOVERNING UNIFORMITY

DOCKET NO. 08-0202-2401

NOTICE OF RULEMAKING – PROPOSED RULE

AUTHORITY: In compliance with Section 67-5221(1), Idaho Code, notice is hereby given that this agency has initiated proposed rulemaking procedures. The action is authorized pursuant to Article IX, Section 2 of the Idaho Constitution and under Sections 33-105, 33-107, 33-116, and 33-1612, Idaho Code.

PUBLIC HEARING SCHEDULE: Public hearing(s) concerning this rulemaking will be scheduled if requested in writing by twenty-five (25) persons, a political subdivision, or an agency, not later than October 16, 2024.

The hearing site(s) will be accessible to persons with disabilities. Requests for accommodation must be made not later than five (5) days prior to the hearing, to the agency address below.

DESCRIPTIVE SUMMARY: The following is a nontechnical explanation of the substance and purpose of the proposed rulemaking:

The amendment to Idaho Code § 33-1203 that resulted from S1069 (2023) provided for a board-approved apprenticeship program to be developed. S1069 also allowed for teacher certifications to be issued to teachers based on completion of four years of college training or the completion of a board approved apprenticeship program. The current language in IDAPA only addresses the four years of college training and needs to be updated to address the additional pathway allowed by this amendment to Idaho Code § 33-1203. A board work group developed the program during 2023, the approval by the board was granted in December of 2023 and the U.S. Department of Labor granted approval in February of 2024. Now that the parameters of the program are established, this rule needs to be amended to align with the program exit requirements before apprentices (who will enter the program in fall of 2024) become eligible to exit. The changes also update the apprenticeship subsection 014 to clarify the federally established minimum age for participation in apprenticeships and aligns the rule with the language in Idaho Code § 33-1203.

Additional amendments realign the JROTC endorsement to program requirements and provide additional clarity for alternative authorizations and certificate renewals.

FEE SUMMARY: The following is a specific description of the fee or charge imposed or increased: NA

FISCAL IMPACT: The following is a specific description, if applicable, of any negative fiscal impact on the state General Fund greater than ten thousand dollars (\$10,000) during the fiscal year resulting from this rulemaking: NA

NEGOTIATED RULEMAKING: Pursuant to Section 67-5220(1), Idaho Code, negotiated rulemaking was conducted. The Notice of Intent to Promulgate Rules - Negotiated Rulemaking was published in the June 5, 2024 Idaho Administrative Bulletin, [Volume 24-6, page 18](#).

INCORPORATION BY REFERENCE: Pursuant to Section 67-5229(2)(a), Idaho Code, the following is a brief synopsis of why the materials cited are being incorporated by reference into this rule: NA

ASSISTANCE ON TECHNICAL QUESTIONS, SUBMISSION OF WRITTEN COMMENTS: For assistance on technical questions concerning the proposed rule, contact Nicholas Wagner at rules@edu.idaho.gov or (208)-488-7586.

Anyone may submit written comments regarding this proposed rulemaking. All written comments must be directed to the undersigned and must be delivered on or before October 23, 2024.

DATED this 23rd day of August, 2024.

Nicholas Wagner
Administrative Rules Coordinator
Idaho State Board of Education
650 W State St.
PO Box 83720
Boise, Idaho 83720-0037
Phone: (208)488-7586, fax: (208)334-2632

THE FOLLOWING IS THE PROPOSED TEXT OF DOCKET NO. 08-0202-2401
(Only Those Sections With Amendments Are Shown.)

08.02.02 – RULES GOVERNING UNIFORMITY

007. DEFINITIONS.

01. **Accredited Institution.** For purposes of educator certification, the Idaho state board of education recognizes accreditation organizations recognized and in good standing with the United States department of education pursuant to IDAPA 08.01.11, registration of postsecondary educational institutions and proprietary schools, section 100, or an alternative or non-traditional model approved by the State Board of Education. ()

02. **Clinical Experience.** Guided, hands-on, practical applications and demonstrations of professional knowledge of theory to practice, skills, and dispositions through collaborative and facilitated learning in field-based assignments, tasks, activities, and assessments across a variety of settings. Clinical experience includes field experience and clinical practice as defined in this section. (3-15-22)

03. **Clinical Practice.** Student teaching or internship opportunities that provide candidates with an intensive and extensive culminating field-based set of responsibilities, assignments, tasks, activities, and assessments that demonstrate candidates' progressive development of the professional knowledge, skills, and dispositions to be effective educators. Clinical practice includes student teaching and internship. (3-15-22)

04. **Credential.** The general term used to denote the document on which all of a person's educational certificates and endorsements are listed. The holder is entitled to provide educational services in any and/or all areas listed on the credential. (3-15-22)

05. **Endorsement.** Term used to refer to the content area or specific area of expertise in which a holder is granted permission to provide services. (3-15-22)

06. **Field Experience.** Early and ongoing practice opportunities to apply content and pedagogical knowledge in Pre-K-12 settings to progressively develop and demonstrate knowledge, skills, and dispositions. (3-15-22)

07. **Individualized Professional Learning Plan.** An individualized professional development plan based on the Idaho framework for teaching evaluation as outlined in Section 120 of these rules to include interventions based on the individual's strengths and areas of needed growth. (3-15-22)

08. **Institutional Recommendation.** Signed form or written verification from an accredited institution with a state board approved educator preparation program stating that an individual has completed the program, received a basic or higher rating in all components of the approved Idaho framework for teaching evaluation, has an individualized professional learning plan, has demonstrated the ability to produce measurable student achievement or

student success, has the ability to create student learning objectives, and is recommended for state certification. Institutional recommendations must include statements of identified competency areas and grade ranges. Institutional recommendation for administrators must additionally include a competency statement indicating proficiency in conducting accurate evaluations of instructional practice based upon the state's framework for evaluation as outlined in Section 120 of these rules. (4-6-23)

089. Internship. Full-time or part-time supervised clinical practice experience in Pre-K-12 settings where candidates progressively develop and demonstrate their knowledge, skills, and dispositions. (3-15-22)

0910. Local Education Agency (LEA). An Idaho public school district or charter school pursuant to Section 33-5203(8), Idaho Code. (3-15-22)

11. Mentoring Program. A state board approved mentoring program means any mentoring program implemented by a school district or public charter school that substantially conforms to the mentorship standards adopted by the State Board of Education. ()

102. Paraprofessional. A noncertificated individual who is employed by a local education agency to support educational programming. Paraprofessionals must work under the direct supervision of a properly certificated staff member for the areas they are providing support. Paraprofessionals cannot serve as the teacher of record and may not provide direct instruction to a student unless the paraprofessional is working under the direct supervision of a teacher. (3-15-22)

a. To qualify as a paraprofessional the individual must have a high school diploma or general equivalency diploma (GED) and: (3-15-22)

i. Demonstrate through a state board approved academic assessment knowledge of and the ability to assist in instructing or preparing students to be instructed in the academic areas they are providing support in; or (4-6-23)

ii. Have completed at least two (2) years of study at an accredited postsecondary educational institution; or (3-15-22)

iii. Obtained an associate degree or higher level degree; demonstrate through a state board approved academic assessment knowledge of and the ability to assist in instructing or preparing students to be instructed in the academic areas they are providing support in. (4-6-23)

b. Individuals who do not meet these requirements will be considered school or classroom aides. (3-15-22)

c. Duties of a paraprofessional include, but are not limited to, one-on-one tutoring; assisting in classroom management; assisting in computer instruction; conducting parent involvement activities; providing instructional support in a library or media center; acting as a translator in instructional matters; and providing instructional support services. Non-instructional duties such as providing technical support for computers, personal care services, and clerical duties are generally performed by classroom or school aides, however, this does not preclude paraprofessionals from also assisting in these non-instructional areas. (3-15-22)

143. Pedagogy. Teaching knowledge and skills. (3-15-22)

124. Portfolio. An organized collection of artifacts that demonstrates an individual's performance, growth, and/or reflection regarding their professional practice, in alignment with the applicable professional standards used for evaluation. (3-15-22)

135. Practicum. Full-time or part-time supervised, industry-based experience in an area of intended career technical education teaching field to extend understanding of industry standards, career development opportunities, and application of technical skills. (3-15-22)

146. Semester Credit Hours. Two (2) semester credit hours are equivalent to three (3) quarter credit

hours. (3-15-22)

157. Student Learning Objective (SLO). A measurable, long-term academic growth target that a teacher sets at the beginning of the year for all student or for subgroups of students. SLOs demonstrate a teacher's impact on student learning within a given interval of instruction based upon baseline data gathered at the beginning of the course. (3-15-22)

168. Student Teaching. Extensive, substantive, and supervised clinical practice in Pre-K-12 schools for candidates preparing for an instructional certificate. (4-6-23)

179. Teacher of Record. The teacher who is primarily responsible for planning instruction, delivering or supervising the instruction provided to a class of students, assessing student performance, and designating final grades. (4-6-23)

~~008. -- 011. (RESERVED)~~

~~**012. ACCREDITED INSTITUTION.**~~

~~For purposes of educator certification, an accredited school, college, university, or other educator training institution is considered by the Idaho State Board of Education to be one that is accredited by a regional accrediting association recognized by the State Board of Education or an alternative or non-traditional model approved by the State Board of Education. (3-15-22)~~

~~008. -- 012. (RESERVED)~~

013. CERTIFICATION OF TEACHERS TRAINED IN FOREIGN INSTITUTIONS.

An educator having graduated from a foreign institution educator preparation program shall be treated as an out of state applicant for certification purposes and may be issued a nonrenewable, three (3) year interim certificate. The applicant must provide transcripts ~~and/or any/or~~ credentials that have been translated and evaluated by an approved evaluation service. (4-6-23)(____)

~~**014. CERTIFICATES ISSUED TO APPLICANTS FROM REGIONALLY ACCREDITED INSTITUTIONS.**~~

~~Idaho certificates may be issued to applicants completing any of the following Idaho State Board of Education approved routes: accredited educator preparation programs ~~from regionally accredited institutions recognized by the state board of education meeting requirements for certification or~~ non-tradition educator preparation program, educator registered apprenticeship programs, a board approved non-traditional or non-public preparation program, an alternative authorization pathway, or the equivalent of Idaho certification requirements in other states when they substantially meet the requirements for a standard Idaho educator certificate. (4-6-23)(____)~~

015. IDAHO EDUCATOR CREDENTIAL.

All standard educator certificates are valid for five (5) years and are renewable, subject to the applicable renewal requirements set by the state board of education and any applicable conditions applied to an individual's certificate by the professional standards commission. (3-15-22)

01. Standard Instructional Certificate. Standard instructional certificates may be issued to completers of traditional routes pursuant to section 33-1203, Idaho code, completers of board approved educator registered apprenticeship programs, or individuals who meet interim certificate requirements. A Standard Instructional Certificate makes an individual eligible to teach all grades, ~~subject to the grade ranges and subject areas of the valid endorsement(s) attached to the certificate. A standard instructional certificate may be issued to any person who has a baccalaureate degree or higher from an accredited college or university and who meets the following requirements or successfully completes an interim certificate requirements and subjects attached to the certificate and valid endorsements. Completors of traditional routes shall meet the following requirements:~~ (4-6-23)(____)

a. Minimum Credit Hours. Earned a minimum of twenty (20) semester credit hours in the philosophical, psychological, methodological foundations, instructional technology, and in the professional subject matter of education, which shall include demonstration of competencies as specified in the Idaho comprehensive literacy plan; and (3-15-22)(____)

b. Student Teaching. Complete a minimum of ten (10) undergraduate or six (6) graduate semester credit hours, of student teaching; and (3-15-22)

c. Complete a state board approved educator preparation program and receive an institutional recommendation from the program specifying the grade ranges and subjects for which the applicant is eligible to receive an endorsement; (4-6-23)

i. To receive endorsement in two (2) fields of teaching, preparation must consist of completion of at least thirty (30) semester credit hours in one (1) field of teaching, and completion of at least twenty (20) semester credit hours in a second field of teaching. (3-15-22)

ii. To receive endorsement in (1) field of teaching, preparation must consist of completion of at least forty-five (45) semester credit hours in a single subject area; (3-15-22)

d. Meet or exceed the state qualifying score on the state board approved content area and pedagogy assessments. (4-6-23)

e. Renewal. Six (6) semester credit hours are required every five (5) years to renew. The renewal credit may be waived if the applicant holds a current, valid certificate from the National Board for Professional Teaching Standards at the time of renewal. Credits must be earned during the validity period of the certificate. ()

02. Standard Pupil Service Staff Certificate. Persons who serve as school counselors, school psychologists, school social workers, and school nurses are required to hold the Standard Pupil Service Staff Certificate, with the respective endorsement(s) for which they qualify. Persons who serve as a speech-language pathologist, school audiologist, occupational therapist, or physical therapist may be required, as determined by the local educational agency, to hold a Standard Pupil Service Staff Certificate with respective endorsements for which they qualify. (4-6-23)

a. School Counselor Endorsement. To be eligible for a School Counselor endorsement, a candidate must have satisfied the following requirements. (3-15-22)

i. Hold a master's degree and provide verification of completion of an approved program of graduate study in school counseling, including sixty (60) semester credits, from a college or university approved by the Idaho State Board of Education or the state educational agency of the state in which the program was completed. The program must include successful completion of seven hundred (700) clock hours of supervised field experience, seventy-five percent (75%) of which must be in a K-12 school setting. This K-12 experience must be in each of the following levels: elementary, middle/junior high, and high school. Previous school counseling experience may be considered to help offset the field experience clock hour requirement; and (3-15-22)

ii. An institutional recommendation is required for a School Counselor endorsement. (3-15-22)

b. School Counselor – Basic Endorsement. (3-15-22)

i. Individuals serving as a school counselor pursuant to Section 33-1212, Idaho Code, shall be granted a School Counselor – Basic endorsement. The endorsement is valid for five (5) years or until such time as the holder no longer meets the eligibility requirements pursuant to Section 33-1212, Idaho Code. (3-15-22)

ii. Individuals who received their endorsement pursuant to Section 33-1212, Idaho Code, prior to July 1, 2018, will be transitioned into the School Counselor – Basic endorsement. Renewal date will remain the same as the initial credential. (3-15-22)

c. School Psychologist Endorsement. The renewal credit requirement may be waived if the applicant holds a current and valid National Certification for School Psychologists (NCSP) offered through the National Association of School Psychologists (NASP). To be eligible for a school psychologist endorsement, a candidate must complete a minimum of sixty (60) graduate semester credit hours which must be accomplished through one (1) of the

following options: (3-15-22)

i. Completion of an approved thirty (30) semester credit hour master's degree in education or psychology and completion of an approved thirty (30) semester credit hour School Psychology Specialist Degree program, and completion of a minimum of twelve hundred (1,200) clock-hour internship within a local education agency under the supervision of the training institution and direct supervision of a certificated school psychologist; (3-15-22)

ii. Completion of an approved sixty (60) semester credit hour, master's degree program in School Psychology, and completion of a minimum of twelve hundred (1,200) clock-hour internship within a local education agency under the supervision of the training institution and direct supervision of a certificated school psychologist; (3-15-22)

iii. Completion of an approved sixty (60) semester credit hour, School Psychology Specialist degree program which did not require a master's degree as a prerequisite, with laboratory experience in a classroom, which may include professional teaching experience, student teaching or special education practicum, and completion of a minimum twelve hundred (1,200) clock-hour internship within a local education agency under the supervision of the training institution and direct supervision of a certificated school psychologist; and (3-15-22)

iv. Earn a current and valid National Certification for School Psychologists (NCSP) issued by the National Association of School Psychologists (NASP). (3-15-22)

d. Interim Certificate – School Psychologist Endorsement. This certificate will be issued to those who do not meet the educational requirements but hold a master’s degree or higher in psychology and are working toward a standard pupil service staff certificate with school psychologist endorsement. This certificate will be issued for three (3) years while the applicant is meeting the educational requirements or obtaining the applicable experience leading to certification. If the educational requirements cannot be met within the three (3)-year time frame of the certificate, the employing LEA may request one (1)-time renewal of this interim certificate for the applicant. (3-15-22)

e. School Nurse Endorsement. To be eligible for a school nurse endorsement, a candidate must complete one (1) of the following options: (3-15-22)

i. Possess a valid professional nursing (RN) license issued by the Idaho State Board of Nursing, and a baccalaureate degree in nursing, education, or a health-related field from an accredited institution. (3-15-22)

ii. Possess a valid professional nursing (RN) license issued by the Idaho State Board of Nursing; have two (2) years of full-time (or part-time equivalent) school nursing, community health nursing, or any other area of pediatric, adolescent, or family nursing experience. (3-15-22)

f. Interim Certificate - School Nurse Endorsement. This certificate will be issued to those who do not meet the educational and/or experience requirements but who hold a valid professional nursing (RN) license in Idaho. This non-renewable certificate will be issued for three (3) years while the applicant is meeting the educational or experience requirements. (3-15-22)

g. Speech-Language Pathologist Endorsement. To be eligible for a speech-language pathologist endorsement, a candidate must possess a master's degree from an accredited college or university in a speech/language pathology program approved by the State Board of Education. The renewal credit requirement may be waived if the applicant holds a current and valid Certificate of Clinical Competence in Speech-Language Pathology offered through the American Speech-Language-Hearing Association and/or a current and valid speech-language pathologist license issued by the appropriate Idaho state licensing board. (3-15-22)

h. Interim Certificate - Speech-Language Pathologist Endorsement. This certificate will be issued to those who do not meet the educational requirements but hold a baccalaureate degree in speech-language pathology and are pursuing a master’s degree. This certificate will be issued for three (3) years while the applicant is meeting the educational requirements. If the educational requirements cannot be met within the three (3)-year timeframe of the certificate, the employing LEA may request one (1)-time renewal of this interim certificate for the applicant if the applicant holds a valid occupational license or is supervised by a speech-language pathologist with a standard pupil

service certificate. (3-15-22)

i. Audiology Endorsement. To be eligible for an audiology endorsement, a candidate must possess a master's degree from an accredited college or university in an audiology program approved by the State Board of Education. The renewal credit requirement may be waived if the applicant holds a current and valid Certificate of Clinical Competence in Audiology offered through the American Speech-Language-Hearing Association and/or a current and valid audiologist license issued by the appropriate Idaho state licensing board. (3-15-22)

j. School Social Worker Endorsement. To be eligible for a school social worker endorsement, a candidate must meet the following requirements: (3-15-22)

i. A master's degree in social work (MSW) from a postsecondary institution accredited by an organization recognized by the State Board of Education. The program must be currently approved by the state educational agency of the state in which the program was completed; and (3-15-22)

ii. An institutional recommendation from a state board approved program; and (3-15-22)

iii. The successful completion of a school social work practicum in a preschool through grade twelve 12 (Pre-K-12) setting. Post-LMSW extensive experience working with children and families may be substituted for the completion of a school social work practicum in a Pre-K-12 setting; and (3-15-22)

iv. A current and valid social work license pursuant to chapter 32, title 54, Idaho Code, and the rules of the State Board of Social Work Examiners. (3-15-22)

k. Occupational Therapist Endorsement. To be eligible for an occupational therapist endorsement, a candidate must have a current and valid occupational therapy license issued by the Occupational Therapy Licensure Board of Idaho. The candidate must maintain current and valid occupational therapy licensure for the endorsement to remain valid. (3-15-22)

l. Physical Therapist Endorsement. To be eligible for a physical therapist endorsement a candidate must have a current and valid physical therapy license issued by the Idaho Physical Therapy Licensure Board. The candidate must maintain current and valid physical therapy licensure for the endorsement to remain valid. (3-15-22)

03. Standard Administrator Certificate. Persons who serve as superintendent, director of special education, secondary school principal, or principal of an elementary school with eight (8) or more teachers (including the principal), or are assigned to conduct the summative evaluation of certified staff are required to hold an Administrator Certificate. The certificate may be endorsed for service as school principal, superintendent, or director of special education. Assistant superintendents are required to hold the Superintendent endorsement. Assistant principals or vice-principals are required to hold the School Principal endorsement. Directors of special education are required to hold the Director of Special Education endorsement. Possession of an Administrator Certificate does not entitle the holder to serve as a teacher at a grade level for which the educator is not qualified or certificated. (3-15-22)

a. School Principal Endorsement. To be eligible for the School Principal endorsement, a candidate must meet the following requirements: (3-15-22)

i. Hold a master's degree from an accredited college or university. (3-15-22)

ii. Have four (4) years of full-time certificated experience working with students, while under contract in an accredited school setting. (3-15-22)

iii. Complete an administrative internship in a state-approved program, or have one (1) year of experience as an administrator. (3-15-22)

iv. Provide verification of completion of a state-approved program of at least thirty (30) semester credit hours of graduate study in school administration for the preparation of school principals at an accredited college or university. This program shall include the demonstration of proficiency in conducting instructional and

pupil service staff evaluations based on the statewide framework for evaluation, and competencies in the Idaho Standards for School Principals. (3-15-22)

v. Receive an institutional recommendation for a School Principal endorsement. (3-15-22)

b. Superintendent Endorsement. To be eligible for the Superintendent endorsement, a candidate must meet the following requirements: (3-15-22)

i. Hold an education specialist or doctorate degree or complete a comparable post-master's sixth year program at an accredited college or university. (3-15-22)

ii. Have four (4) years of full-time certificated/licensed experience working with students while under contract in an accredited school setting. (3-15-22)

iii. Complete an administrative internship in a state board approved program for the superintendent endorsement or have one (1) year of out-of-state experience as an assistant superintendent or superintendent. (3-15-22)

iv. Provide verification of completion of an approved program of at least thirty (30) semester credit hours, of post-master's degree graduate study for the preparation of school superintendents at an accredited college or university. This program in school administration must include demonstration of proficiency in conducting instructional and pupil service staff evaluations based on the statewide framework for evaluation, and demonstration of competencies in the Idaho standards for superintendents and the Idaho Standards for School Principals. (3-15-22)

v. Receive an institutional recommendation for a Superintendent endorsement. (3-15-22)

c. Director of Special Education Endorsement. To be eligible for the Director of Special Education endorsement, a candidate must meet the following requirements: (3-15-22)

i. Hold a master's degree from an accredited college or university; (3-15-22)

ii. Have four (4) years of full-time certificated/licensed experience working with students Pre-K-12, while under contract in a school setting; (3-15-22)

iii. Provide verification of a state board approved program of graduate study of school administration for the preparation of directors of special education at an accredited college or university. This program shall include demonstration of proficiency in conducting instructional and pupil service staff evaluations based on the statewide framework for evaluation, and demonstration of competencies in the Idaho Standards for Directors of Special Education and the Idaho Standards for School Principals. Coursework shall include knowledge and competence in understanding the Individuals with Disabilities Education Act, utilizing the Idaho Special Education Manual, special education funding and fiscal accountability, results-driven leadership and accountability in special education, and instructional, behavioral, and management strategies for supporting students in the least restrictive environment. (3-15-22)

iv. Have completed an administrative internship in the area of administration of special education; and (3-15-22)

v. An institutional recommendation is required for Director of Special Education endorsement. (3-15-22)

04. Career Technical Certification Requirements. Teachers of career technical courses or programs in secondary schools must hold an occupational specialist certificate and an endorsement in an appropriate occupational discipline. All occupational certificates must be approved by the Division of Career Technical Education regardless of the route an individual is pursuing to receive the certificate. (3-15-22)

a. Standard Degree Based Career Technical Certificate. Persons who hold a degree based career technical certificate are eligible to teach in a career technical area, subject to the grade range(s) and subject area(s) of

the valid endorsement(s) attached to the certificate. All degree based career technical certificates require candidates to meet the Idaho Core Teaching Standards. The degree based career technical certificate is valid for five years. A degree based career technical certificate may be issued to any person who has a baccalaureate degree from an accredited college or university and meets the following requirements: (3-15-22)

i. Earned a minimum of twenty (20) semester credit hours in the philosophical, psychological, methodological foundations, instructional technology, and in the professional subject matter of education, which shall include demonstration of competencies as specified in the Idaho Comprehensive Literacy Plan; (3-15-22)

ii. Earned a minimum of twelve (12) semester credit hours in career technical education foundation coursework to include principles and philosophies of career technical education, evaluation and assessment in career technical education, leadership and career technical student organization leadership, career guidance and transition, occupational analysis and curriculum development, and lab safety; (3-15-22)

iii. Accumulated one thousand (1,000) clock hours of related industry experience, or practicum as approved by the higher education institution, in the respective field of specialization; (3-15-22)

iv. Completed a total of at least ten (10) undergraduate semester credit hours or six (6) graduate semester credit hours of student teaching; (3-15-22)

v. Completed a state board approved educator preparation program and received an institutional recommendation specifying the grade ranges and subjects for which the person is eligible to receive an endorsement; (3-15-22)

(1) To receive endorsement in two (2) fields of teaching, preparation must consist of at least thirty (30) semester credit hours in one (1) field of teaching and completion of at least twenty (20) semester credit hours in a second field of teaching. (3-15-22)

(2) To receive endorsement in one (1) field of teaching, preparation must consist of completion of at least forty-five (45) semester credit hours in a single subject area. (3-15-22)

vi. Met or exceeded the state qualifying score on the state board-approved content area and pedagogy assessments. (3-15-22)

vii. The renewal credits required in Section 060 may be waived if the applicant holds a current, valid certificate from the National Board for Professional Teaching Standards at the time of renewal. Credits must be earned during the validity period of the certificate. (4-6-23)

b. Career Technical Education Program Administrator Certificate. The career technical education program administrator certificate is required for an individual serving as an administrator, director, or manager of career technical education programs in Idaho public schools. Individuals must meet one (1) of the two (2) following prerequisites to qualify for the career technical education program administrator certificate. The certificate is valid for five (5) years and must meet the renewal requirements pursuant to Section 060 of these rules to renew. (4-6-23)

i. Qualify for or hold an advanced occupational specialist certificate or hold an occupational endorsement on a degree based career technical certificate; provide evidence of a minimum of four (4) years teaching, three (3) of which must be in a career technical education discipline; hold a master's degree; and complete at least fifteen (15) semester credits of administrative course work to include required credits in education finance, administration and supervision of personnel, and legal aspects of education. Remaining coursework may be selected from: administration and supervision of occupational programs; instructional supervision; administration internship; curriculum development; curriculum evaluation; research in curriculum; school community relations; communication; teaching the adult learner; coordination of work-based learning programs; and/or measurement and evaluation. (3-15-22)

ii. Hold a superintendent or principal endorsement on a standard administrator certificate and provide evidence of either a minimum of four (4) years teaching, three (3) of which must be in a career technical discipline; or successful completion of a Division of Career Technical Education career technical education leadership institute; or

completion of course work including credits in: principles and foundations of career technical education, career technical student organizations, occupational analysis, curriculum design, one or more externships with career technical education industry advisor partners totaling 100 hours, and ongoing participation in technical advisory committee meetings associated with the school's career technical education programs. (4-6-23)

c. Industry-Based Occupational Specialist Certificate. Persons who hold an occupational specialist career technical certificate are eligible to teach in a career technical program pathway(s), subject to the grade range(s) and pathway areas(s) of the valid endorsement(s) attached to the certificate. All occupational specialist career technical certificates require candidates to meet the core teaching standards of the Idaho Standards for Initial Certification of Professional School Personnel. An occupational specialist career technical certificate may be issued to an experienced industry expert entering the teaching profession and meeting the following eligibility requirements: (3-15-22)

i. Possess either a high school diploma or General Educational Development (GED) certificate; meet provisions of Idaho Code; and, verify technical skills through work experience, industry certification or testing as listed below. When applicable, requirements of occupationally related state agencies must also be met. Since educational levels and work experiences vary, applicants may be determined qualified under any one (1) of the following three (3) options: (3-15-22)

(1) Have three (3) years or six thousand (6,000) hours of recent, gainful employment in the occupation for which certification is requested, at least half of which must have been during the immediate previous five (5) years; or (3-15-22)

(2) Have a baccalaureate degree in the specific occupation or related area, plus one (1) year or two thousand (2,000) hours of recent, gainful employment in the occupation for which certification is requested, at least half of which must have been during the immediate previous five (5) years; or (3-15-22)

(3) Hold or have held an industry certification in a field closely related to the content area in which the individual seeks to teach as approved by the Division of Career Technical Education. (3-15-22)

ii. Limited Occupational Specialist Certificate. This certificate is issued to individuals who are new to teaching in Idaho public schools or new to teaching in career technical education in Idaho public schools. The certificate is an interim certificate and is valid for three (3) years and is non-renewable. Applicants must meet all of the minimum requirements established in Subsection 015.06.a. of these rules. Individuals on a limited occupational specialist certificate must complete one (1) of the two (2) following pathways during the validity period of the certificate: (3-15-22)

(1) Pathway I - Coursework: Within the three-year period of the Limited Occupational Specialist Certificate, the instructor must satisfactorily complete the pre-service training prescribed by the Division of Career Technical Education and demonstrate competencies in principles/foundations of occupational education and methods of teaching occupational education. Additionally, the instructor must satisfactorily demonstrate competencies in two (2) of the following areas: career pathways and guidance; analysis, integration, and curriculum development; and measurement and evaluation. (3-15-22)

(2) Pathway II – Cohort Training: Within the first twelve (12) months, the holder must enroll in the Division of Career Technical Education sponsored education pedagogy training and complete all requirements within the three-year validity period of the interim certificate. (3-15-22)

iii. Standard Occupational Specialist Certificate. (3-15-22)

(1) This certificate is issued to individuals who have held a limited occupational specialist certificate and completed one (1) of the pathways for renewable certification. (3-15-22)

(2) The Standard Occupational Specialist Certificate is valid for five (5) years and must meet the renewal requirements pursuant to Section 060 of these rules to renew. Credit equivalency will be based on verification of forty-five (45) hours of participation at approved technical conferences, institutes, or workshops where participation is prorated at the rate of fifteen (15) hours per credit; or one hundred twenty (120) hours of approved

related work experience where hours worked may be prorated at the rate of forty (4) hours per credit; or any equivalent combination thereof. (4-6-23)

iv. **Advanced Occupational Specialist Certificate.** This certificate is issued to individuals who are eligible for the Standard Occupational Specialist Certificate; and provide evidence of completion of a teacher training degree program or eighteen (18) semester credits of Division of Career Technical Education approved education or content-related course work in addition to the twelve (12) semester credits required for the Standard Occupational Specialist Certificate (a total of thirty (30) semester credits. The Advanced Occupational Specialist Certificate is valid for five (5) years and must meet the renewal requirements pursuant to Section 060 of these rules to renew. (4-6-23)

05. Postsecondary Specialist Certificate. A Postsecondary Specialist certificate will be granted to a current academic faculty member whose primary employment is with any accredited Idaho postsecondary institution. To be eligible to teach in the public schools under this postsecondary specialist certificate, the candidate must supply a recommendation from the employing institution (faculty's college dean). The primary use of this state-issued certificate is for distance education, virtual classroom programs, and public and postsecondary partnerships. (3-15-22)

a. To renew this certificate, the renewal application must be accompanied with a new written recommendation from the postsecondary institution (faculty's college dean level or higher). (3-15-22)

b. The candidate must meet the following qualifications: (3-15-22)

i. Hold a baccalaureate degree or higher in the content area being taught; (3-15-22)

ii. Be currently employed by the postsecondary institution in the content area to be taught; and (3-15-22)

iii. Complete and pass a criminal history background check as required by Section 33-130, Idaho Code. (3-15-22)

06. American Indian Tribal Language Certificate. The five (5) federally recognized tribes of Idaho shall provide to the State Department of Education the names of those highly and uniquely qualified individuals who have been designated to teach tribal language(s) in accordance with Section 33-1280, Idaho Code. To be eligible for an American Indian Tribal Languages certificate an applicant designated to teach tribal language(s) shall submit a complete application. If approved the certificate shall be issued for five years and is renewable. (3-15-22)

07. Junior Reserved Officer Training Corps (Junior ROTC) Instructors. (3-15-22)

a. Junior ROTC Instructor Certificate. To be eligible for a five (5) year renewable Junior ROTC Instructor certificate, an applicant shall submit a complete application and provide a copy of their certificate(s) or letter of completion of an letter of recommendation from their hiring school district or public charter school and a copy of their certificate or letter of completion from an armed forces Junior ROTC training program. (3-15-22)()

b. If approved the certificate shall be issued for five years and is renewable Interim Certificate – Junior ROTC Instructor. A three (3) year interim certificate shall be issued to those who are enrolled in the Junior ROTC Instructor training program. The applicant shall submit a complete application, a letter of recommendation from their hiring school district or public charter school, and a copy of their Junior ROTC Instructor initial qualification letter issued by an armed forces Junior ROTC training program. (3-15-22)()

08. Additional Renewal Requirements. In addition to specific certificate or endorsement renewal requirements, applicants must meet the following renewal requirements as applicable: (3-15-22)

a. **Administrator certificate renewal.** In order to recertify, holders of an administrator certificate must complete a course consisting of a minimum of three (3) semester credits in the Idaho framework for teachers' evaluation pursuant to Section 33-1204, Idaho Code. Credits must be earned through an approved educator

preparation program and include a laboratory component. The laboratory component must include in-person or video observation and scoring of teacher performance using the statewide framework for teacher's evaluation. The approved course must include the following competencies: (3-15-22)

i. Understanding professional practice in Idaho evaluation requirements, including gathering accurate evidence and artifacts, understanding and using the state framework for evaluation rubric with fidelity, proof of calibration and interrater reliability, ability to provide effective feedback for teacher growth, and understanding and advising teachers on individualized learning plan and portfolio development. (3-15-22)

ii. Understanding student achievement and growth in the Idaho evaluation framework, including understanding how measurable student achievement and growth measures impact summative evaluation ratings and proficiency in assessment literacy. (3-15-22)

016. IDAHO INTERIM CERTIFICATE.

A three (3) year interim certificate may be issued to applicants who hold a valid certificate or license from another state or other entity that participates in the National Association of State Directors of Teacher Education and Certification (NASDTEC) Interstate Agreement pursuant to Section 33-4104, Idaho Code, or who are engaged in or completed a non-traditional route or alternative authorization to certification as prescribed herein. An interim certificate gives the holder the same rights and responsibilities as an individual with a standard certificate. (4-6-23)

01. Interim Certificate Not Renewable. Interim certification is only available on a one (1) time basis except under extenuating circumstances approved by the State Department of Education or Division of Career Technical Education. An applicant must meet the requirements of the ~~applicable alternate authorization route or non-traditional route~~ interim certificate to obtain a standard Idaho Educator Credential during the term of the interim certificate. (3-15-22)()

02. Non-Traditional Route to Teacher Certification. An individual may acquire interim certification through a state board approved non-traditional route to teacher certification program. The non-traditional route may be used for first-time certification, subsequent certificates, and additional endorsements. (3-15-22)

a. Individuals who possess a baccalaureate degree or higher from an institution of higher education accredited by an entity recognized by the state board of education may receive an interim instructional certificate. To receive the interim certificate, the individual must: (3-15-22)

i. Complete or enroll in a state board approved program; and (3-15-22)

ii. Pass the state board approved pedagogy and content area assessment. (3-15-22)

b. Standard certification. Upon completion of the non-traditional route the applicant must complete a two (2) year state board approved teacher mentoring program and receive two (2) years of Idaho evaluations with a summative rating of proficient or better. (4-6-23)

03. Idaho Comprehensive Literacy Course. All Idaho teachers working on an interim certificate (alternate authorizations, nontraditional routes, reinstatement, or coming from out of state), must complete a state board approved Idaho Comprehensive Literacy course or assessment as a one-time requirement for standard instructional certificate. (3-15-22)

04. Teaching For Mathematical Thinking. All Idaho teachers or administrators with an interim certificate (alternate authorizations, nontraditional routes, reinstatement, or coming from out of state), with an All Subjects (K-8) endorsement, any mathematics endorsement, Exceptional Child Education endorsement, Blended Early Childhood/Early Childhood Special Education endorsement, or Administrator certificate must complete the state board approved Teaching for Mathematical Thinking course as a one-time requirement for full certification. (4-6-23)()

05. Reinstatement of a Certificate Expired for One (1) Year or Less. An individual with an Idaho certificate expired for one (1) year or less who did not meet the six (6)-credit renewal requirement may apply for reinstatement and be issued an interim certificate. During the validity period of the interim certificate, the applicant

must complete any outstanding credits to meet the renewal requirement to be eligible for a five (5)-year renewable certificate. ()

056. Reinstatement of ~~Expired~~ a Certificate Expired for Over One (1) Year. An individual ~~holding with an expired~~ Idaho certificate expired for over one (1) year may apply for reinstatement and be issued an interim certificate. During the validity period of the interim certificate, the applicant must meet the following requirements to ~~obtain standard certification during the term of the interim~~ be eligible for a five (5)-year renewable certificate: (3-15-22)()

a. Two (2) years of Idaho evaluations, as applicable to the type of certification, with a summative rating of proficient or better; (4-6-23)

b. Measured annual progress on specific goals identified on the applicant's Individualized Professional Learning Plan; (3-15-22)

c. Completion of the six (6) credit renewal requirement; and (4-6-23)()

d. Completion of the Idaho Comprehensive Literacy Course or Teaching for Mathematical Thinking as provided herein. (3-15-22)

~~e. Individuals holding an expired certificate that was in good standing at the time the certificate expired, may have the certificate reinstated within one (1) year of the time the certificate expired by completing any outstanding professional development requirements that were pending at the time the certificate expired.~~ (4-6-23)

067. Codes of Ethics. All laws and rules governing standard certificated staff with respect to conduct, discipline, and professional standards shall apply to all certified staff serving in an Idaho public school, including those employed under an interim certificate. (3-15-22)

(BREAK IN CONTINUITY OF SECTIONS)

021. ENDORSEMENTS.

Holders of an Instructional Certificate or Occupational Specialist Certificate must have one (1) or more endorsements attached to their certificate as applicable to the type of certification. Instructional staff are eligible to teach in the grades and content areas of their endorsements. Idaho educator preparation programs shall prepare candidates for endorsements in accordance with these certification requirements and the standards approved by the board. An official statement from the college of education of competency in a content area or field is acceptable in lieu of required credits if such statements are created in consultation with the department or division of the accredited college or university in which the competency is established and are approved by the director of teacher education of the recommending college or university. Statements must include the number of credits the competency evaluation is equivalent to. To add an endorsement to a certificate, an individual must complete the credit hour requirements as established by the state board of education and meet or exceed the state qualifying score on a board approved content, pedagogy or performance assessment. (4-6-23)

01. Clinical Experience Requirement. All standard endorsements require supervised clinical experience in the relevant content area, or a State Department of Education or Division of Career Technical Education approved alternative clinical experience as applicable to the area of endorsement. (4-6-23)

02. Alternative Authorization - Teacher to New Endorsement. This alternative authorization allows a local education agency to request additional endorsement for a candidate. This authorization is valid for one (1) year and may be renewed for two (2) additional years with evidence of satisfactory progress on one (1) of the following options: (4-6-23)

a. Option I -- An official statement of competency in a teaching area or field from the college of education of an accredited college or university is acceptable in lieu of courses if the statement is created in consultation with the department or division in which the competency is established and is approved by the director

of teacher education of the recommending college or university. (3-15-22)

b. Option II -- Master's degree or higher. ~~By earning a graduate degree in a content specific area, A candidates may add an endorsement in that same content area to a valid instructional certificate. Successful completion of~~ by successfully completing a one (1) year, state board approved mentoring program ~~must be completed during~~ within the first year ~~to maintain the endorsement of authorization.~~ (4-6-23)()

c. Option III -- Content area assessment and mentoring. A candidate may add an endorsement by successfully completing a state board-approved content areas assessment and a one-year, state board-approved mentoring program within the first year of authorization. (3-15-22)

d. For all candidates moving to an initial certification in a career technical education endorsement area, the candidate will be required to complete or have completed coursework in principles and foundations of career technical education and career technical student organizations, training in occupational analysis and curriculum design, and a minimum of two hundred (200) internship/externship hours in the career technical education endorsement area. (4-6-23)

03. **National Board Certification.** An applicant holding an instructional certificate and current national board certification may add an endorsement in a corresponding content-specific area. (3-15-22)

(BREAK IN CONTINUITY OF SECTIONS)

042. ALTERNATIVE AUTHORIZATION.

Alternative authorization allows a local education agency to request certification for a candidate. This authorization grants an interim certificate that allows individuals to serve as the teacher of record while pursuing standard certification. ~~Evidence of satisfactory progress toward standard certification must be provided each year.~~ Individuals who hold a current instructional certificate may obtain additional endorsements through an alternative authorization as prescribed in Subsection 021 of these rules. (4-6-23)()

01. **Alternative Authorization -- Teacher to New Certification.** This alternative authorization allows a local education agency to request additional certification for a candidate who already holds a current Idaho certificate in good standing to add an additional type of certificate in a new certification area. (4-6-23)

a. ~~Prior to application, the candidate must hold a baccalaureate degree or higher and a current and valid Idaho certificate.~~ The local education agency must attest to the candidate's ability to fill the position. (3-15-22)()

b. The candidate must participate in a state board- approved educator preparation program. (3-15-22)

i. The candidate will work toward completion of a state board-approved educator preparation program. ~~The candidate must complete a minimum of nine (9) semester credits annually to maintain continued eligibility for the interim certificate;~~ and (4-6-23)()

ii. The participating educator preparation program shall provide procedures to assess and credit equivalent knowledge, dispositions, and relevant life/work experiences toward program completion requirements. (4-6-23)

02. **Alternative Authorization -- Content Specialist.** This alternative authorization allows a local education agency to request an interim instructional certificate for an individual who possesses distinct content knowledge and skills to teach in a content area. (4-6-23)()

a. Initial Qualifications. (3-15-22)

i. A candidate must hold a baccalaureate degree or have completed all of the requirements of a baccalaureate degree except the student teaching portion; and (3-15-22)

ii. Prior to entering the classroom, the local education agency shall ensure the candidate is qualified to teach in the content area. The candidate shall meet or exceed the state qualifying score on the appropriate state board-approved content or pedagogy assessment, including demonstration of content knowledge through a combination of employment, experience, and education. (3-15-22)

b. State Board Approved Educator Preparation Program. (3-15-22)

i. Prior to authorization, a consortium comprised of a state board-approved educator preparation program representative, a local education agency representative, and the candidate shall determine the preparation needed and develop a plan to meet the Idaho Standards for Initial Certification of Professional School Personnel. The educator preparation program shall provide procedures to assess and credit: equivalent knowledge, dispositions, and relevant life or work experiences. The plan must include a state board-approved mentoring program. While teaching under the alternative authorization, the mentor shall provide a minimum of one (1) classroom observation per month, which will include feedback and reflection. ~~The plan must include annual progress goals that must be met for continued eligibility;~~ (4-6-23)()

ii. ~~The candidate must complete a minimum of nine (9) semester credit hours or its equivalent of accelerated study in education pedagogy prior to the end of the first year of authorization.~~ The number of required credits will be specified in the ~~consortium~~ developed plan; and (3-15-22)()

iii. ~~At the time of authorization~~ During the validity period of the interim certificate, the candidate must ~~enroll in and work toward completion of~~ complete the plan. ~~The candidate must complete a minimum of nine (9) semester credits or equivalent annually to maintain eligibility for the interim certificate. The candidate must complete the plan to move to a standard instructional certificate to receive an institutional recommendation for a standard instructional certificate.~~ (4-6-23)()

c. Career Technical Education Industry-based Route Plan. Local education agencies with candidates seeking a limited occupational specialist certification may request approval, with an approved division of career technical education alternative authorization route plan, to meet the program of study requirements. (4-6-23)

03. Alternative Authorization - Pupil Service Staff. This alternative authorization allows a local education agency to request an interim certification and endorsement certificate for a candidate when a position requiring the Pupil Service Staff Certificate cannot be filled. (4-6-23)()

a. Initial Qualifications. The applicant must complete the following: (3-15-22)

i. Prior to application, a candidate must hold a baccalaureate degree or higher; and (3-15-22)

ii. The local education agency must attest to the ability of the candidate to fill the position. (3-15-22)

b. Educator Preparation Program. (3-15-22)

~~i. At the time of authorization the candidate must enroll in and work toward completion of a state board approved educator preparation program through a participating college or university and the local education agency. The educator preparation program must include annual progress goals. (4-6-23)~~

~~ii. The candidate must complete a minimum of nine (9) semester credits or equivalent annually to maintain eligibility for the interim certificate. (4-6-23)~~

i. The number of required credits will be specified in a plan developed by the Educator Preparation Program; and ()

ii. During the validity period of the interim certificate, the candidate must complete the plan to receive an institutional recommendation for a standard pupil service staff certificate. ()

iii. The participating educator preparation program will provide procedures to assess and credit

equivalent knowledge, dispositions, and relevant life/work experiences. (3-15-22)

- iv. ~~The candidate must meet all requirements for the endorsement/certificate as provided herein.~~ (3-15-22)

(BREAK IN CONTINUITY OF SECTIONS)

100. OFFICIAL VEHICLE FOR APPROVING EDUCATOR PREPARATION PROGRAMS.

01. The Official Vehicle for the Approval of Traditional Educator Preparation Programs. Traditional educator preparation programs will be accredited by an accrediting body that approves educator preparation programs and is recognized by the state board of education and meets the board approved Idaho Standards for the Initial Certification of Professional School Personnel. The Idaho Standards for the Initial Certification of Professional School Personnel will be posted on the state board of education and state department of education websites. All standards will include an implementation date. (4-6-23)

02. Non-Traditional Educator Preparation Program. To be considered for approval each non-traditional educator preparation program must include the following components: (3-15-22)

- a. Assessment of pedagogy and content knowledge; and (3-15-22)
- b. Alignment to the Idaho Standards for the Initial Certification of Professional School Personnel. (3-15-22)

03. Continuing Approval. Approved educator preparation programs will be reviewed for continued approval on a timeline and in a format established by the state board of education. Program reviews will take into consideration the instructional methodology used by the approved program. (3-15-22)

~~**04. Payment Responsibilities for Educator Preparation Program Reviews.** The Professional Standards Commission is responsible for Idaho educator preparation program reviews, including assigning responsibility for paying for program reviews. To implement the reviews, it is necessary that:~~ (3-15-22)

- ~~a. The Professional Standards Commission pay for all state review team expenses for on-site teacher preparation reviews from its budget. (3-15-22)~~
- ~~b. Requesting institutions pay for all other expenses related to on-site educator preparation program reviews, including all standards review. (3-15-22)~~

IDAPA 08 – STATE BOARD OF EDUCATION

08.02.03 – RULES GOVERNING THOROUGHNESS

DOCKET NO. 08-0203-2401

NOTICE OF RULEMAKING – PROPOSED RULE

AUTHORITY: In compliance with Section 67-5221(1), Idaho Code, notice is hereby given that this agency has initiated proposed rulemaking procedures. The action is authorized pursuant to Article IX, Section 2 of the Idaho Constitution and under sections 33-105, 33-116, 33-118, and 33-1612, Idaho Code.

PUBLIC HEARING SCHEDULE: Public hearing(s) concerning this rulemaking will be scheduled if requested in writing by twenty-five (25) persons, a political subdivision, or an agency, not later than October 16, 2024.

The hearing site(s) will be accessible to persons with disabilities. Requests for accommodation must be made not later than five (5) days prior to the hearing, to the agency address below.

DESCRIPTIVE SUMMARY: The following is a nontechnical explanation of the substance and purpose of the proposed rulemaking:

Changes to subsection 105 regarding High school Graduation Requirements were reviewed by a committee facilitated by the IDE throughout the 2023-2024 school year at the request of the Superintendent of Public Instruction. Idaho is considering modernizing the traditional graduation system to better accommodate variable pathways.

FEE SUMMARY: The following is a specific description of the fee or charge imposed or increased: NA

FISCAL IMPACT: The following is a specific description, if applicable, of any negative fiscal impact on the state General Fund greater than ten thousand dollars (\$10,000) during the fiscal year resulting from this rulemaking: NA

NEGOTIATED RULEMAKING: Pursuant to Section 67-5220(1), Idaho Code, negotiated rulemaking was conducted. The Notice of Intent to Promulgate Rules - Negotiated Rulemaking was published in the June 5, 2024 Idaho Administrative Bulletin, [Volume 24-6, page 20](#).

INCORPORATION BY REFERENCE: Pursuant to Section 67-5229(2)(a), Idaho Code, the following is a brief synopsis of why the materials cited are being incorporated by reference into this rule:

The Idaho Department of Education (IDE) is requesting the Board promulgate rules and incorporated by reference documents in IDAPA 08.02.03. Several sets of content standards, which are incorporated by reference into IDAPA 08.02.03, were due for review during the 2023- 2024 school year and the revisions proposed by the committee work were adopted on June 12, 2024. These approval dates need to be updated in the rule. Content standards that were revised include: Arts and Humanities, Computer Science, Information and Communication Technology, Driver Education, and Social Studies.

The Idaho Special Education Manual, incorporated by reference into IDAPA 08.02.03, was revised to ensure compliance with the Individuals with Disabilities Act, as the Idaho Department of Education was notified in October of 2023 of non-compliance by the U.S. Department of Education, Office of Special Education Programs, OSEP. Specifically, the manual must be updated regarding student eligibility requirements. This change is addressed through a separate temporary rule which will expire upon adjournment sine die 2025. Revisions to this manual were adopted on August 21, 2024. Section 109 of this rule is proposed to be removed as it is duplicative of the Special Education Manual incorporated by reference.

A thorough review of graduation requirements, facilitated by the IDE, was conducted in 2024. On August 21, 2024, The State Board of Education approved the IDE's recommendation to move forward with the proposed changes to administrative rule to reflect this work. Language in the revisions reflects the intent to phase in the changes to be in full effect for the graduating class of 2028.

ASSISTANCE ON TECHNICAL QUESTIONS, SUBMISSION OF WRITTEN COMMENTS: For assistance on technical questions concerning the proposed rule, contact Nicholas Wagner at rules@edu.idaho.gov or (208)-488-7586.

Anyone may submit written comments regarding this proposed rulemaking. All written comments must be directed to the undersigned and must be delivered on or before October 23, 2024.

DATED this 23rd day of August, 2024.

Nicholas Wagner
Administrative Rules Coordinator
Idaho State Board of Education
650 W State St.
PO Box 83720
Boise, Idaho 83720-0037
Phone: (208)488-7586, fax: (208)334-2632

**THE FOLLOWING IS THE PROPOSED TEXT OF DOCKET NO. 08-0203-2401
(Only Those Sections With Amendments Are Shown.)**

08.02.03 – RULES GOVERNING THOROUGHNESS

004. INCORPORATION BY REFERENCE.

The following documents are incorporated into this rule: (3-15-22)

01. The Idaho Content Standards. The Idaho Content Standards as adopted by the State Board of Education. Individual subject content standards are adopted in various years in relation to the curricular materials adoption schedule. Copies of the document can be found on the State Board of Education website at <https://boardofed.idaho.gov>. (3-15-22)

- a.** Arts and Humanities Categories: (3-15-22)
 - i. Dance, as revised and adopted on ~~August 11, 2016~~ June 12, 2024; (3-15-22)()
 - ii. Interdisciplinary Humanities, as revised and adopted on ~~August 11, 2016~~ June 12, 2024; (3-15-22)()
 - iii. Media Arts, as adopted on ~~August 11, 2016~~ June 12, 2024. (3-15-22)()
 - iv. Music, as revised and adopted on ~~August 11, 2016~~ June 12, 2024; (3-15-22)()
 - v. Theater, as revised and adopted on ~~August 11, 2016~~ June 12, 2024; (3-15-22)()
 - vi. Visual Arts, as revised and adopted on ~~August 11, 2016~~ June 12, 2024; (3-15-22)()
 - vii. World languages, as revised and adopted on ~~August 11, 2016~~ June 12, 2024. (3-15-22)()
- b.** Computer Science, adopted on ~~November 28, 2016~~ June 12, 2024. (3-15-22)()

- c. Driver Education, as revised and adopted on ~~August 10, 2017~~ June 12, 2024. (3-15-22)()
- d. Health, as revised and adopted on August 24, 2022. (4-6-23)
- e. Information and Communication Technology, as revised and adopted on ~~August 10, 2017~~ June 12, 2024. (3-15-22)()
- f. Physical Education, as revised and adopted on August 24, 2022. (4-6-23)
- g. Social Studies, as revised and adopted on ~~November 28, 2016~~ June 12, 2024. (3-15-22)()
- h. College and Career Readiness Competencies adopted on June 15, 2017. (3-15-22)
- 02. The Idaho Standards for Infants, Toddlers, Children, and Youth Who Are Deaf or Hard of Hearing.** As adopted by the State Board of Education on October 11, 2007. Copies of the document can be found on the State Board of Education website at <https://boardofed.idaho.gov>. (3-15-22)
- 03. The Idaho Standards for Infants, Toddlers, Children, and Youth Who Are Blind or Visually Impaired.** As adopted by the State Board of Education on October 11, 2007. Copies of the document can be found on the State Board of Education website at <https://boardofed.idaho.gov>. (3-15-22)
- 04. The Idaho Special Education Manual.** The Idaho Special Education Manual as adopted by the State Board of Education on ~~October 17, 2018~~ August 21, 2024. Copies of the document can be found on the State Board of Education website at <https://boardofed.idaho.gov>. (3-15-22)()
- 005. -- 006. (RESERVED)**
- 007. DEFINITIONS.**
- 01. Achievement Standards.** Define “below basic,” “basic,” “proficient,” and “advanced” achievement levels on the Idaho Standards Achievement Tests (ISAT) and level one (1) through level six (6) on Idaho’s English language assessment by setting scale score cut points. These cut scores are set by the state board of education and paired with descriptions of how well students are mastering the material in the content standards. These descriptions are called achievement level descriptors and are provided by achievement level, by content area, and by grade. (4-6-23)
- 02. Advanced Opportunities.** Advanced placement courses, Dual Credit courses, ~~Technical Competency Credit~~ micro credentials, or International Baccalaureate programs. (4-6-23)()
- 03. Advanced Placement® (AP) - College Board.** The Advanced Placement Program is administered by the College Board at <http://www.collegeboard.com>. AP students may take one (1) or more college level courses in a variety of subjects. AP courses are not tied to a specific college curriculum, but rather follow national College Board curricula. While taking the AP exam is optional, students can earn college credit by scoring well on the national exams. It is up to the discretion of the receiving college to accept the scores from the AP exams to award college credit or advanced standing. (3-15-22)
- 04. All Students.** All public school students, grades K-12. (3-15-22)
- 05. Applied Science.** Applying scientific knowledge to practical problems or situations. ()
- 056. Assessment.** The process of quantifying, describing, or gathering information about skills, knowledge or performance. (3-15-22)
- 067. Assessment Standards.** Statements setting forth guidelines for evaluating student work, as in the “Standards for the Assessment of Reading and Writing.” (3-15-22)
- 078. Career Pathway Plan.** The plan that outlines a student’s program of study, which should include a

rigorous academic core and a related sequence of electives in academic, career technical education (CTE), or humanities aligned with the student's post-graduation goals. (3-15-22)

089. **Career Technical Education.** Formal preparation for semi-skilled, skilled, technical, or paraprofessional occupations, usually below the baccalaureate level. (3-15-22)

0910. **College and Career Readiness.** College and career readiness is the attainment and demonstration of state board adopted competencies that broadly prepare high school graduates for a successful transition into some form of postsecondary education and/or the workplace. (3-15-22)

101. **Content Standards.** Describe the knowledge, concepts, and skills that students are expected to acquire at each grade level in each content area. (3-15-22)

142. **Criteria.** Guidelines, rules or principles by which student responses, products, or performances, are judged. What is valued and expected in the student performance, when written down and used in assessment, become rubrics or scoring guides. (3-15-22)

123. **Diploma.** A document awarded to a student by a secondary school to show the student has successfully completed the state and local education agency graduation requirements. Diplomas may be awarded to individuals who attended a secondary school prior to the year in which the student is requesting issuance of a diploma based on the graduation requirements in existence at the time the student attended. Determination of meeting past graduation requirements may be determined based on proficiency as determined by the local education agency. Each local education agency may determine the format of the diploma, including the recognition of emphasis areas based on a student's completion of courses or courses or studies in an emphasis area or educational pathways, including but not limited to science, technology, engineering and math (STEM), career technical education, or arts and music. (3-15-22)

134. **Dual Credit.** Dual credit allows high school students to simultaneously earn credit toward a high school diploma and a postsecondary degree or certificate. ~~Postsecondary institutions work closely with high schools to deliver college courses that are identical to those offered on the college campus. Credits earned in a dual credit class become part of the student's permanent college record. Students may enroll in dual credit programs taught at the high school or on the college campus.~~ (3-15-22)()

145. **Idaho Standards Achievement Tests.** Statewide assessments aligned to the state content standards and used to measure a student's knowledge of the applicable content standards. (3-15-22)

156. **International Baccalaureate (IB).** Administered by the International Baccalaureate Organization, the IB program provides a comprehensive liberal arts course of study for students in their junior and senior years of high school. IB students take end-of-course exams that may qualify for college credit. Successful completion of the full course of study leads to an IB diploma. (3-15-22)

167. **Laboratory.** A laboratory course is defined as one in which at least one (1) class period each week is devoted to providing students with the opportunity to manipulate equipment, materials, specimens or develop skills in observation and analysis and discover, demonstrate, illustrate or test scientific principles or concepts. (3-15-22)

18. **Localized Pathway.** A framework of locally provided offerings that identifies core and elective credits, assessments, and other opportunities aligned to post-secondary goals. Local Education Agencies determine their own framework and students may select offerings aligned with localized pathways. ()

179. **Portfolio.** A digital or physical collection of materials that documents and demonstrates a student's academic and work-based learning. ~~A portfolio typically includes many forms of information that exhibit the student's knowledge, skills, and interests. By building a portfolio, students can recognize their own growth and learn to take increased responsibility for their education. Teachers, mentors, and employers can use portfolios for assessment purposes and to record educational outcomes.~~ (3-15-22)()

1820. **Project Based Learning.** A hands-on approach to learning that encourages students to create/interpret/communicate an original work or project and assesses quality and success of learning through performance/

presentation/production of that work or project. (3-15-22)

~~19~~**21. Proficiency.** Having or demonstrating a high degree of knowledge or skill in a particular area. (3-15-22)

~~20~~**2. Standards.** Statements about what is valued in a given field, such as English language arts, and/or descriptions of what is considered quality work. See content standards, assessment standards, and achievement standards. (3-15-22)

~~21~~**4. Technical Competency Credit.** Technical competency credit is a sequenced program of study that allows secondary students to document proficiency in the skills and abilities they develop in approved high school career technical programs to be evaluated for postsecondary transcription at a later date. Technical Competency Credits are awarded for skills and competencies identified as eligible through an agreement with at least one Idaho postsecondary institution. Eligible skills and competencies are included as part of a high school career technical program and approved by the postsecondary institution through the agreement in advance to student participation. Credits are granted by the postsecondary institution for which the agreement is with and are transcribed at the time the student enrolls at the postsecondary institution. (3-15-22)

~~22~~**4. Technology Education.** A curriculum for elementary, middle, and senior high schools that integrates learning about technology (e.g., transportation, materials, communication, manufacturing, power and energy, and biotechnology) with problem-solving projects that require students to work in teams. Many technology education classrooms and laboratories are well equipped with computers, basic hand tools, simple robots, electronic devices, and other resources found in most communities today. (3-15-22)

~~23~~**5. Unique Student Identifier.** A number issued and assigned by the Board or designee to each student currently enrolled or who will be enrolled in an Idaho local education agency to obtain data. (3-15-22)

~~26~~**6. Work-Based Learning.** Structured learning experiences that connect classroom learning to the workplace. Work-based learning can include technical, academic and employability skills gained in a simulated or real work environment. ()

(BREAK IN CONTINUITY OF SECTIONS)

105. HIGH SCHOOL GRADUATION REQUIREMENTS.

A student must meet all of the requirements identified in this section before the student will be eligible to graduate from an Idaho high school. The local school district or LEA may establish graduation requirements beyond the state minimum. (3-15-22)

01. Credit Requirements. The State minimum graduation requirement for all Idaho public high schools is forty-six (46) credits and must include twenty-nine (29) credits in core subjects as identified in Paragraphs 105.01.c. through 105.01.h. (3-15-22)

a. Credits. One (1) credit shall equal sixty (60) hours of total instruction. School districts or LEA's may request a waiver from this provision by submitting a letter to the State Department of Education for approval, signed by the superintendent and chair of the board of trustees of the district or LEA. The waiver request shall provide information and documentation that substantiates the school district or LEA's reason for not requiring sixty (60) hours of total instruction per credit. (3-15-22)

b. Mastery. Students must demonstrate mastery of Idaho Content Standards in a format provided by the LEA. Notwithstanding the credit definition of Subsection 105.01.a., a student may also achieve credits by demonstrating mastery of a subject's content standards as defined and approved by the ~~local education agency (LEA.)~~ (3-15-22)()

c. Credit Flexibility. The State Department of Education will support LEAs in the development of crosswalks and templates to assist in awarding credit for prior learning in ways that meet course requirements for

high school graduation. ()

ed. Secondary Language Arts and Communication. ~~Nine (9) credits are required.~~ Eight (8) credits of instruction in Language Arts. Each year of Language Arts shall consist of language study, composition, and literature and be aligned to the Idaho Content Standards for the appropriate grade level. One (1) credit of instruction in communications will apply for any student graduating before January 1, 2028 and will consist of oral communication and technological applications that includes a course in speech, a course in debate, or a sequence of instructional activities that meet the Idaho Speech Content Standards requirements. Instruction in communications consisting of oral communication and technological applications through a sequence of instructional activities that meet the Idaho Speech and Content standards shall be required for any student graduating after January 1, 2028. (3-15-22)()

de. Mathematics. Six (6) credits are required. Secondary mathematics includes Integrated Mathematics, Applied Mathematics, Business Mathematics, Algebra, Geometry, Trigonometry, Fundamentals of Calculus, Probability and Statistics, Discrete Mathematics, and courses in mathematical problem solving and quantitative reasoning including mathematics taken through career technical education programs. ~~Dual credit~~ Engineering courses and computer science courses aligned to the state standards for grades nine (9) through (12), including AP Computer Science and dual credit computer science courses may also be counted as a mathematics credit. Students who choose to take computer science ~~and dual credit~~ or engineering courses may not concurrently count such courses as both a mathematics and science credit for the same course. (4-6-23)()

i. Students must complete secondary mathematics in the following areas: (3-15-22)

(1) Two (2) credits of Algebra I, Algebra I level equivalent Integrated Mathematics or courses that meet the High School Algebra Content Standards; (3-15-22)

(2) Two (2) credits of Geometry, Geometry level equivalent Integrated Mathematics, or courses that meet the Idaho High School Geometry Content Standards; and (3-15-22)

(3) Two (2) credits of mathematics of the student's choice. (3-15-22)

ef. Science. Six (6) credits are required, ~~two (2) of which will be laboratory based.~~ Four credits are required from at least two (2) of the four content areas: physics, chemistry, earth and space or life science. Two (2) credits in Secondary sciences may include instruction in applied sciences, physics, chemistry, earth and space sciences, ~~physical sciences,~~ life sciences, ~~and or~~ computer science. Engineering courses and computer science courses aligned to the state standards for grades nine (9) through (12), may also be counted as a science credit. (3-15-22)()

~~i. Secondary sciences include instruction in the following areas: biology, computer science, physical science or chemistry, and earth, space, environment, or approved applied science.~~ (3-15-22)

fg. Social Studies. Five (5) credits are required, including government (two (2) credits), United States history (two (2) credits), and economics and financial literacy (one (1) credit). Courses such as geography, sociology, psychology, and world history may be offered as electives, but are not to be counted as a social studies requirement. (4-6-23)

gh. ~~Humanities~~ Fine Arts or World Languages. Two (2) credits are required. ~~Humanities e~~ Courses include instruction in visual arts, music, theatre, dance, or world languages s aligned to the Idaho content standards for those subjects. Other courses such as literature, history, philosophy, architecture, or comparative world religions may satisfy the humanities standards if the course is aligned to the Interdisciplinary Humanities Content Standards. (3-15-22)()

hi. Health/Wellness. One (1) credit is required. Course must be aligned to the Idaho Health Content Standards. ~~Effective for all public school students who enter grade nine (9) in Fall 2015 or later, e~~ Each student shall receive a minimum of one (1) ~~class period~~ training on psychomotor cardiopulmonary resuscitation (CPR) training as outlined in the American Heart Association (AHA) Guidelines for CPR to include the proper utilization of an automatic external defibrillator (AED) as part of the Health/Wellness course. (3-15-22)()

ij. Physical Education. Students participating in one (1) season in any sport recognized by the Idaho High School Activities Association or club sport recognized by the local school district, or eighteen (18) weeks of a sport recognized by the local school district may choose to substitute participation up to one (1) credit of physical education. Students must show mastery of the Physical Education Content Standards in a format provided by the school district LEA. (3-15-22)()

k. Digital Literacy. One (1) credit is required. The course must include instruction that aligns with Idaho Content Standards associated with leveraging technology, digital citizenship, and computational thinking which are imbedded in the Information and Communication Technology Content Standards, and with leveraging the impacts of computing, algorithms, and programming, which are embedded in the Computer Science Standards. This requirement will apply to any student graduating after January 1, 2028. ()

02. Content Standards. Each student shall meet locally established subject area standards (using state content standards as minimum requirements) demonstrated through various measures of accountability including examinations or other measures. (3-15-22)

03. Senior Project. The senior project is a culminating project to show a student's ability to analyze, synthesize, and evaluate information and communicate that knowledge and understanding. A student must complete a senior project by the end of grade twelve (12). Senior projects may be multi-year projects, group or individual projects, or approved pre-internship or school to work internship programs, at the discretion of the school district or charter school. The project must include elements of research, development of a thesis using experiential learning or integrated project based learning experiences and presentation of the project outcome. Additional requirements for a senior project are at the discretion of the local school district or LEA. Completion of a postsecondary certificate or degree at the time of high school graduation or an approved pre-internship or internship program may be used to meet this requirement. The senior project will last apply for the class of 2027, unless an LEA opts to early implement the future readiness project. (3-15-22)()

04. Future Readiness Project. The future readiness project is a culminating project that demonstrates a student's application of college and career competencies and exploration of potential post high school options. All students beginning with the class of 2028 must complete a future readiness project by the end of grade twelve (12). The project must include an experiential component, such as a work-based, service-based, research-based, or portfolio-based component in which a student demonstrates the acquisition of Idaho college and career competencies. Experiences including, but not limited to apprenticeships, internships, volunteer work and extracurricular activities related to real-world skills acquisition will count toward this requirement. LEAs must determine how students will demonstrate the acquisition of college and career competencies and may require additional components. The State Department of Education will provide templates for LEAs and oversee the implementation of this provision. ()

05. Localized Pathways. In order to assist students in structuring their secondary course selection electives, assessment, and supplemental activities, all LEAs shall develop and post publicly two or more localized pathways. Localized pathways are designed to inform students and parents/guardians of local opportunities aligned with post-secondary goals as identified in the student's career pathway plan. The State Department of Education shall support the implementation of this provision. This provision must be implemented by all LEAs no later than June 30, 2026. ()

046. Civics and Government Proficiency. Pursuant to Section 33-1602, Idaho Code, each LEA may establish an alternate path for determining if a student has met the state civics and government content standards. Alternate paths are open to all students in grades seven (7) through twelve (12.) Any student who has been determined proficient in the state civics and government content standards either through the completion of the civics test or an alternate path shall have it noted on the student's high school transcript. (3-15-22)

057. Middle School. A student will have met the high school content and credit area requirement for any high school course if the requirements outlined in Subsections 105.06.a. through 105.06.c. of this rule are met. (3-15-22)

- a.** The student completes such course with a grade of C or higher before entering grade nine (9); (3-15-22)

b. The course meets the same content standards that are required in high school for the same course; (3-15-22)
and

c. The course is taught by a teacher properly certified to teach high school content and who meets the federal definition of highly qualified for the course being taught. (3-15-22)

d. The student shall be given a grade for the successful completion of that course and such grade and the number of credit hours assigned to the course will be transferred to the student's high school transcript. Notwithstanding this requirement, the student's parent or guardian shall be notified in advance when credits are going to be transcribed and may elect to not have the credits and grade transferred to the student's high school transcript. Courses taken in middle school appearing in the student's high school transcript, pursuant to this subsection, shall count for the purpose of high school graduation. However, the student must complete the required number of credits in all high school core subjects as identified in Subsections 105.01.c. through 105.01.h. except as provided in 105.01.d.iii. The transcribing high school is required to verify the course meets the requirements specified in Subsections 105.05.a. through 105.05.c. of this rule. (3-15-22)

068. Special Education Students. A student who is eligible for special education services under the Individuals With Disabilities Education Improvement Act may, with the assistance of the student's Individualized Education Program (IEP) team, meet the graduation requirements through to the current Idaho Special Education Manual specifications. (3-15-22)

079. Foreign Exchange Students. A foreign exchange student may be eligible for graduation by completing a comparable program as approved by the LEA. (3-15-22)

(BREAK IN CONTINUITY OF SECTIONS)

~~109. SPECIAL EDUCATION.~~

~~**01. Definitions.** The following definitions apply only to Section 109 of these rules. (3-15-22)~~

~~**a. Adult Student.** A student who is eligible for special education, is eighteen (18) years of age or older and to whom special education rights have transferred. (3-15-22)~~

~~**b. Due Process Hearing.** An administrative hearing that is conducted to resolve disputes. (3-15-22)~~

~~**i. Regular due process hearing regarding issues on any matter related to identification, evaluation, placement, or the provision of a free appropriate public education. (3-15-22)**~~

~~**ii. For disputes concerning discipline for which shortened time lines are in effect, an expedited due process hearing may be requested in accordance with the Individuals with Disabilities Education Act. (3-15-22)**~~

~~**e. Education Agency.** Each school district and other public agency that is responsible for providing special education and related services to students with disabilities, including the Department of Juvenile Corrections and the Idaho School for the Deaf and Blind. (3-15-22)~~

~~**d. Idaho Special Education Manual.** Policies and procedures, as approved by the State Board of Education, that the State Department of Education is required to adopt to meet the eligibility requirements of 20 U.S.C, Section 1412 and are consistent with state and federal laws, rules, regulations, and legal requirements. (3-15-22)~~

~~**e. Special Education.** Specially designed instruction as defined by the Individuals with Disabilities Education Act or speech language pathology services to meet the unique needs of a special education student. (3-15-22)~~

~~02. Legal Compliance. The State Department of Education and education agencies shall comply with all laws governing special education requirements. (3-15-22)~~

~~a. The Board of Trustees or other comparable governing body of each education agency shall adopt policies and procedures for providing special education services and obtain approval from the State Department of Education for the same. Department approval shall be based on current governing special education requirements. Each education agency shall revise its policies and procedures as necessary to conform with changes in governing special education requirements. (3-15-22)~~

~~b. The State Department of Education shall provide education agencies with a sample set of policies and procedures that is consistent with governing special education requirements. The Department shall monitor all education agencies and private agencies who provide special education services to students with disabilities for compliance with governing special education requirements and adopted policies and procedures. (3-15-22)~~

~~c. Each education agency shall ensure that charter schools and alternative schools located in its jurisdiction have nondiscriminatory enrollment practices. Each education agency shall ensure the provision of special education and related services to eligible students enrolled in charter and alternative schools in accordance with governing special education requirements. (3-15-22)~~

~~d. Each education agency contracting with a private school or facility shall ensure that the private school or facility is approved by the State Department of Education to provide special education services. The Department may approve a private school or facility to provide special education services upon application to the Department if it: (3-15-22)~~

~~i. Is an accredited school or a licensed rehabilitation center; and (3-15-22)~~

~~ii. Meets minimum health, fire and safety standards; and (3-15-22)~~

~~iii. Is nonsectarian; and (3-15-22)~~

~~iv. Provides special education services consistent with governing special education requirements. (3-15-22)~~

~~v. Any private school or facility aggrieved by the Department's final decision may appeal that decision to the State Board of Education. (3-15-22)~~

~~e. Education agencies shall employ special education and related services professional personnel using certification standards approved by the State Board of Education or licensing standards adopted by the appropriate Idaho state licensing board. Education agencies shall employ individuals who meet the highest entry-level standard that applies to a specific discipline unless there is a shortage of fully qualified candidates for a specific position. If there is a shortage of fully qualified candidates, the education agency shall hire the most qualified individual available who is making satisfactory progress toward meeting the highest entry-level standard within three (3) years. (3-15-22)~~

~~f. Education agencies may employ paraprofessional personnel to assist in the provision of special education and related services to students with disabilities if they meet standards established by the State Department of Education. (3-15-22)~~

~~g. Education agencies shall collect and report data as necessary to meet state and federal requirements concerning special education services, staff or students. Education agencies shall develop, implement and revise district improvement plans as necessary to improve results as measured by data on goals and indicators for the performance of special education students that are established by the State Department of Education in accordance with the Individuals with Disabilities Education Act. (3-15-22)~~

~~h. Education agencies shall establish a team process to problem solve and plan general education interventions to ensure that referrals to special education are appropriate. (3-15-22)~~

~~**03. Eligibility for Special Education.** The State Department of Education shall provide state eligibility criteria for special education services for categorical eligibility consistent with the Individuals with Disabilities Education Act. Education agencies shall consider eligibility under all disability categories set forth in the Idaho Special Education Manual with the exception of developmental delay, which is an optional category. If an education agency elects to use the developmental delay category, it shall consider developmental delay for students ages three (3) through nine (9) using the eligibility criteria adopted by the Department and set forth in the Idaho Special Education Manual. The total timeline from the date of receipt of written parental consent for an initial evaluation to the date of determination of eligibility for special education and related services must not exceed sixty (60) calendar days, excluding periods when regular school is not in session for five (5) or more consecutive school days, unless all parties agree to an extension. (3-15-22)~~

~~**04. Individualized Education Programs.** Each education agency shall develop an individualized education program (IEP) for each student who is eligible for special education. The IEP shall be implemented as soon as possible after it is developed. The total timeline from the determination that the student needs special education and related services to the date of implementation of the initial IEP shall not exceed thirty (30) calendar days. A new IEP shall be developed at least annually, on or before the date the previous IEP was developed. (3-15-22)~~

~~**a.** IEP team meetings shall be convened upon reasonable request of any IEP team member at times other than the annual review. If the education agency refuses to convene an IEP team meeting requested by a parent or adult student, the agency shall provide written notice of the refusal. (3-15-22)~~

~~**b.** Education agencies shall document the attendance of all participants at each IEP team meeting. Any participant who does not agree with an IEP team decision regarding a student's educational program may place a minority report in that student's file. A minority report shall not prevent implementation of an IEP team decision. (3-15-22)~~

~~**c.** The IEP team shall determine the student's placement in the least restrictive environment. (3-15-22)~~

~~**d.** At the discretion of the education agency, an individualized family service plan (IFSP) may be used in place of an IEP if: (3-15-22)~~

~~**i.** The child is ages three (3) through five (5), and (3-15-22)~~

~~**ii.** The child's parents are provided with a detailed explanation of the differences between an IFSP and an IEP, and (3-15-22)~~

~~**iii.** The child's parents provide written consent to use the IFSP, and (3-15-22)~~

~~**iv.** The IFSP is developed in accordance with IDEA Part B policies and procedures. (3-15-22)~~

~~**v.** Nothing in this part requires education agencies to develop IFSPs rather than IEPs for three (3) through five (5) year old nor to implement more than the educational components of the IFSP. (3-15-22)~~

~~**e.** When a student who has been determined eligible for special education, as indicated by a current IEP, transfers from one (1) Idaho education agency to another, the student is entitled to continue to receive special education services. The receiving education agency may accept and implement the existing IEP or may convene an IEP team meeting to develop a new IEP. If a new IEP cannot be developed within five (5) school days, or if the education agency wishes to re-evaluate the child, an interim (short-term) IEP shall be implemented pending development of the standard IEP. (3-15-22)~~

~~**f.** If a student who is eligible for special education in another state transfers to an Idaho education agency, the Idaho education agency shall request a copy of the student's most recent eligibility documentation and IEP within two (2) school days. Within five (5) school days of receipt of the eligibility documentation and IEP, the Idaho education agency shall determine if it will adopt the existing eligibility documentation and IEP. If the education agency disagrees with the existing eligibility documentation, or if the documentation is not available within a reasonable time period, consent for an initial assessment shall be sought. While the assessment and evaluation is in~~

~~process, the education agency may implement an interim IEP if the parent or adult student agrees. If the parent or adult student does not agree to an interim IEP, the student shall be placed in general education. (3-15-22)~~

~~**05. Procedural Safeguards.** Education agencies will use appropriate procedural safeguards consistent with the Individuals with Disabilities Education Act. (3-15-22)~~

~~**a.** If a parent or adult student disagrees with an individualized education program (IEP) team's proposed IEP for the student, the parent or adult student may file a written objection to all or parts of the proposed IEP. If the written objection is emailed, postmarked or hand delivered within ten (10) calendar days of the date the parent or adult student receives written notice of the proposed IEP, the proposed change cannot be implemented for fifteen (15) calendar days, or as extended through mutual agreement by the district and the parent or adult student while the parties work to resolve the dispute. Parties may choose to hold additional IEP team meetings which may be facilitated by the State Department of Education (SDE) or request voluntary mediation through the SDE. If these methods fail or are refused, the proposed IEP shall be implemented after fifteen (15) calendar days unless a due process hearing is filed by the parents or adult student, during which time the student shall remain in the current educational placement during the pendency of any administrative or judicial proceeding, unless the district/adult student agree otherwise. The written objection cannot be used to prevent the education agency from placing a student in an interim alternative educational setting in accordance with IDEA discipline procedures, or to challenge an eligibility/identification determination. (3-15-22)~~

~~**b.** Mediation may be requested by an education agency, parent, or adult student, or offered by the State Department of Education at any time. The Department shall screen all such requests to determine appropriateness. Any time a hearing is requested, the Department shall offer mediation using policies and requirements set forth in the Individuals with Disabilities Education Act regulations. If the Department appoints a mediator, the Department shall be responsible for compensating the mediator. All mediation participants will receive a copy of the Notification of Mediation Confidentiality form. Attorney fees may not be awarded for a mediation that is conducted prior to a request for a due process hearing. (3-15-22)~~

~~**c.** The State Department of Education shall administer a single tiered due process hearing system to resolve disputes between education agencies and parents or adult students. When a due process hearing is requested, the superintendent, special education director, or other agency administrator shall inform the agency's board of trustees or other governing body of the request. The education agency shall immediately notify the Department's Director of Special Education of any request for a due process hearing. Within ten (10) calendar days of a written request for a regular hearing, or within five (5) business days of a written request for an expedited hearing, an impartial hearing officer shall be assigned by the Department. The Department shall maintain a list of trained hearing officers and their qualifications. (3-15-22)~~

~~**d.** The education agency that is a party to the hearing shall be responsible for compensating the hearing officer and paying for the cost of a verbatim transcript of the hearing. (3-15-22)~~

~~**e.** Due process hearings shall be conducted pursuant to IDAPA 04.11.01, "Idaho Rules of Administrative Procedure of the Attorney General," Individuals with Disabilities Education Act requirements, and the Idaho Special Education Manual, incorporated by reference in Section 004 of this rule. In case of any conflict between the IDAPA 04.11.01, "Idaho Rules of Administrative Procedure of the Attorney General" and the IDEA, the IDEA shall supersede the IDAPA 04.11.01, and IDAPA 04.11.01 shall supersede the Idaho Special Education Manual. (3-15-22)~~

~~**f.** The hearing officer shall issue a written decision that includes findings of fact and conclusions of law within forty five (45) calendar days of the date a regular hearing is requested, unless a specific extension of this time line is requested by one (1) of the parties and granted by the hearing officer. The hearing officer shall issue a written decision that includes findings of fact and conclusions of law within twenty (20) calendar days of a written request for an expedited hearing, unless a specific extension of this time line has been granted. An extension of the time line for an expedited hearing shall not exceed an additional twenty five (25) calendar days, and may be granted only if requested by one (1) of the parties and agreed to by both parties. The decision shall be sent to the parent or adult student, the education agency administrator, their respective representatives, and the State Department of Education. (3-15-22)~~

~~g.~~ The hearing officer's decision shall be binding unless either party appeals the decision by initiating a civil action. The hearing officer's decision shall be implemented not later than fourteen (14) calendar days from the date of issuance unless an appeal is filed by a parent or adult student or the decision specifies a different implementation date. An appeal to civil court must be filed within forty-two (42) calendar days from the date of issuance of the hearing officer's decision. (3-15-22)

~~h.~~ During the hearing the education agency shall provide reasonable accommodations as required by federal and state regulations. Disputes concerning reasonable accommodations shall be referred to the U.S. Department of Education's Americans with Disabilities Act (ADA) Committee for resolution. (3-15-22)

~~i.~~ During the pendency of any due process hearing or civil appeal the child's educational placement shall be determined by the Individuals with Disabilities Education Act "stay put" requirements. (3-15-22)

~~j.~~ A parent or adult student has the right to an independent educational evaluation (IEE) at public expense if the parent or adult student disagrees with an evaluation obtained by the education agency. Whenever an IEE is at public expense, the criteria under which the evaluation is obtained, including the location of the evaluation and the qualifications of the examiner, shall be the same as the criteria the education agency uses when it initiates an evaluation, to the extent those criteria are consistent with the parent or adult student's right to an IEE. If an education agency has cost as one (1) of the criteria the education agency uses when it initiates an evaluation, the education agency may apply that criteria to independent educational evaluations. However, the parent or adult student has the right to demonstrate that unique circumstances justify an IEE that falls outside the education agency's cost criteria, and if so demonstrated, that IEE shall be publicly funded. A due process hearing may be initiated by the education agency to determine if the evaluation conducted by the education agency is appropriate. If the final decision of a hearing officer, or civil court, if the hearing officer's decision is appealed, is that the evaluation conducted by the education agency is appropriate, the parent or adult student still has the right to an independent educational evaluation, but not at the education agency's expense. (3-15-22)

~~k.~~ Student records shall be managed in accordance with IDEA and Family and Educational Rights and Privacy Act regulations governing security, confidentiality, access, maintenance, destruction, inspection and amendment. (3-15-22)

06. Assistive Technology Devices. Education agencies may hold a parent liable for the replacement or repair of an assistive technology device that is purchased or otherwise procured by the education agency if it is lost, stolen, or damaged due to negligence or misuse at home or in another setting outside of school time. (3-15-22)

07. Diplomas and Graduation. School districts shall use a regular diploma for students who are eligible for special education at the completion of their secondary program. The transcript serves as a record of individual accomplishments, achievements, and courses completed. A modified or differentiated diploma or certificate may not be used for students who are eligible for special education unless the same diploma or certificate is granted to students without disabilities. If a student is not granted a regular high school diploma or if a regular high school diploma is granted for completing requirements that are not comparable to regular graduation requirements, a student who is eligible for special education is entitled to receive a free appropriate public education through the semester in which the student turns twenty-one (21) years of age or until the student completes requirements that are comparable to regular graduation requirements, whichever comes first. (3-15-22)

08. Special Education Advisory Panel. The State Superintendent of Public Instruction shall appoint members to serve on the Special Education Advisory Panel. Panel members shall elect annually an individual to serve a one (1) year term as vice chair followed by a one (1) year term as chair. (3-15-22)

109. (RESERVED)

IDAPA 08 – STATE BOARD OF EDUCATION

08.02.03 – RULES GOVERNING THOROUGHNESS

DOCKET NO. 08-0203-2403

NOTICE OF RULEMAKING – ADOPTION OF TEMPORARY RULE

EFFECTIVE DATE: The effective date of the temporary rule is August 21, 2024.

AUTHORITY: In compliance with Sections 67-5226, Idaho Code, notice is hereby given this agency has adopted a temporary rule. The action is authorized pursuant to Sections 33-105, 33-116, 33-118, and 33-1612, Idaho Code.

DESCRIPTIVE SUMMARY: The following is the required finding and concise statement of its supporting reasons for adopting a temporary rule:

The rule will be updated to reflect that the Board adopted revisions to the Special Education Manual on June 12, 2024. The Special Education Manual is incorporated by reference into IDAPA 08.02.03. The proposed amendments to the Idaho Special Education Manual include updates primarily regarding student eligibility to receive services.

Additionally several sets of content standards, which are incorporated by reference into IDAPA 08.02.03, were due for review during the 2023-2024 school year and the revisions proposed by the committee work have been adopted by the Board. These approval dates need to be updated in the rule. Content standards that were revised include: Arts and Humanities, Computer Science, Information and Communication Technology, Driver Education, and Social Studies.

TEMPORARY RULE JUSTIFICATION: Pursuant to Section(s) 67-5226(1) (b), Idaho Code, the Governor has found that temporary adoption of the rule is appropriate for the following reasons:

In December of 2023, the Idaho Department of Education (IDE) was informed by letter from the U.S. Office of Special Education Programs (OSEP) that the Idaho Special Education Manual needed revision. The IDE recently completed the revision, including public comment period. It is necessary to pursue a temporary rule to ensure that schools begin the school year with a compliant special education manual. The document is incorporated by reference into IDAPA 08.02.03, and therefore no resolution can be achieved without amendment to the rule. It is proposed that subsection 109 be removed as all of the information is included in the manual which is incorporated by reference. There is no need for the information to be repeated.

Additionally, this is the second Temp Rule for 08.02.03 in the 2024-25 rulemaking cycle. The new temp rule carries over the updates to the content standards previously approved in the Temp Rule (08-0203-2402) approved by the Board at the June 12, 2024 meeting. The updates in the previous temporary rule are regarding content standards that are incorporated by reference into IDAPA 08.02.03. IDAPA 08.02.03 must be updated to reflect adopted revisions to the documents incorporated by reference.

FEE SUMMARY: Pursuant to Section 67-5226(2), the Governor has found that the fee or charge being imposed or increased is justified and necessary to avoid immediate danger and the fee is described herein: NA

ASSISTANCE ON TECHNICAL QUESTIONS: For assistance on technical questions concerning the temporary rule, contact Nicholas Wagner at rules@edu.idaho.gov or (208)-488-7586).

DATED this 30th day of August, 2024.

Nicholas Wagner
Administrative Rules Coordinator
Idaho State Board of Education
650 W State St.
PO Box 83720
Boise, Idaho 83720-0037
Phone: (208)488-7586, fax: (208)334-2632

THE FOLLOWING IS THE TEXT OF THE TEMPORARY RULE FOR DOCKET NO. 08-0203-2403
(Only Those Sections With Amendments Are Shown.)

08.02.03 – RULES GOVERNING THOROUGHNESS

004. INCORPORATION BY REFERENCE.

The following documents are incorporated into this rule: (3-15-22)

01. The Idaho Content Standards. The Idaho Content Standards as adopted by the State Board of Education. Individual subject content standards are adopted in various years in relation to the curricular materials adoption schedule. Copies of the document can be found on the State Board of Education website at <https://boardofed.idaho.gov>. (3-15-22)

- a.** Arts and Humanities Categories: (3-15-22)
 - i.** Dance, as revised and adopted on June 12, 2024; (7-1-24)T
 - ii.** Interdisciplinary Humanities, as revised and adopted on June 12, 2024; (7-1-24)T
 - iii.** Media Arts, as adopted on June 12, 2024. (7-1-24)T
 - iv.** Music, as revised and adopted on June 12, 2024; (7-1-24)T
 - v.** Theater, as revised and adopted on June 12, 2024; (7-1-24)T
 - vi.** Visual Arts, as revised and adopted on June 12, 2024; (7-1-24)T
 - vii.** World languages, as revised and adopted on June 12, 2024. (7-1-24)T
- b.** Computer Science, adopted on June 12, 2024. (7-1-24)T
- c.** Driver Education, as revised and adopted on June 12, 2024. (7-1-24)T
- d.** Health, as revised and adopted on August 24, 2022. (4-6-23)
- e.** Information and Communication Technology, as revised and adopted on August 10, 2017. (3-15-22)
- f.** Physical Education, as revised and adopted on August 24, 2022. (4-6-23)
- g.** Social Studies, as revised and adopted on June 12, 2024. (7-1-24)T
- h.** College and Career Readiness Competencies adopted on June 15, 2017. (3-15-22)

02. The Idaho Standards for Infants, Toddlers, Children, and Youth Who Are Deaf or Hard of Hearing. As adopted by the State Board of Education on October 11, 2007. Copies of the document can be found on the State Board of Education website at <https://boardofed.idaho.gov>. (3-15-22)

03. The Idaho Standards for Infants, Toddlers, Children, and Youth Who Are Blind or Visually Impaired. As adopted by the State Board of Education on October 11, 2007. Copies of the document can be found on the State Board of Education website at <https://boardofed.idaho.gov>. (3-15-22)

04. The Idaho Special Education Manual. The Idaho Special Education Manual as adopted by the State Board of Education on ~~October 17, 2018~~ August 21, 2024. Copies of the document can be found on the State Board of Education website at <https://boardofed.idaho.gov>. (3-15-22)(8-21-24)T

109. SPECIAL EDUCATION.

- 01. Definitions.** The following definitions apply only to Section 109 of these rules. (3-15-22)
- a. Adult Student.** A student who is eligible for special education, is eighteen (18) years of age or older and to whom special education rights have transferred. (3-15-22)
 - b. Due Process Hearing.** An administrative hearing that is conducted to resolve disputes. (3-15-22)
 - i.** Regular due process hearing regarding issues on any matter related to identification, evaluation, placement, or the provision of a free appropriate public education. (3-15-22)
 - ii.** For disputes concerning discipline for which shortened time lines are in effect, an expedited due process hearing may be requested in accordance with the Individuals with Disabilities Education Act. (3-15-22)
 - c. Education Agency.** Each school district and other public agency that is responsible for providing special education and related services to students with disabilities, including the Department of Juvenile Corrections and the Idaho School for the Deaf and Blind. (3-15-22)
 - d. Idaho Special Education Manual.** Policies and procedures, as approved by the State Board of Education, that the State Department of Education is required to adopt to meet the eligibility requirements of 20 U.S.C. Section 1412 and are consistent with state and federal laws, rules, regulations, and legal requirements. (3-15-22)
 - e. Special Education.** Specially designed instruction as defined by the Individuals with Disabilities Education Act or speech language pathology services to meet the unique needs of a special education student. (3-15-22)
- 02. Legal Compliance.** The State Department of Education and education agencies shall comply with all laws governing special education requirements. (3-15-22)
- a.** The Board of Trustees or other comparable governing body of each education agency shall adopt policies and procedures for providing special education services and obtain approval from the State Department of Education for the same. Department approval shall be based on current governing special education requirements. Each education agency shall revise its policies and procedures as necessary to conform with changes in governing special education requirements. (3-15-22)
 - b.** The State Department of Education shall provide education agencies with a sample set of policies and procedures that is consistent with governing special education requirements. The Department shall monitor all education agencies and private agencies who provide special education services to students with disabilities for compliance with governing special education requirements and adopted policies and procedures. (3-15-22)
 - c.** Each education agency shall ensure that charter schools and alternative schools located in its jurisdiction have nondiscriminatory enrollment practices. Each education agency shall ensure the provision of special education and related services to eligible students enrolled in charter and alternative schools in accordance with governing special education requirements. (3-15-22)
 - d.** Each education agency contracting with a private school or facility shall ensure that the private school or facility is approved by the State Department of Education to provide special education services. The Department may approve a private school or facility to provide special education services upon application to the Department if it:
 - i.** Is an accredited school or a licensed rehabilitation center; and (3-15-22)

- ii. Meets minimum health, fire and safety standards; and (3-15-22)
- iii. Is nonsectarian; and (3-15-22)
- iv. Provides special education services consistent with governing special education requirements. (3-15-22)
- v. Any private school or facility aggrieved by the Department's final decision may appeal that decision to the State Board of Education. (3-15-22)

~~e. Education agencies shall employ special education and related services professional personnel using certification standards approved by the State Board of Education or licensing standards adopted by the appropriate Idaho state licensing board. Education agencies shall employ individuals who meet the highest entry-level standard that applies to a specific discipline unless there is a shortage of fully qualified candidates for a specific position. If there is a shortage of fully qualified candidates, the education agency shall hire the most qualified individual available who is making satisfactory progress toward meeting the highest entry level standard within three (3) years. (3-15-22)~~

~~f. Education agencies may employ paraprofessional personnel to assist in the provision of special education and related services to students with disabilities if they meet standards established by the State Department of Education. (3-15-22)~~

~~g. Education agencies shall collect and report data as necessary to meet state and federal requirements concerning special education services, staff or students. Education agencies shall develop, implement and revise district improvement plans as necessary to improve results as measured by data on goals and indicators for the performance of special education students that are established by the State Department of Education in accordance with the Individuals with Disabilities Education Act. (3-15-22)~~

~~h. Education agencies shall establish a team process to problem solve and plan general education interventions to ensure that referrals to special education are appropriate. (3-15-22)~~

~~**03. Eligibility for Special Education.** The State Department of Education shall provide state eligibility criteria for special education services for categorical eligibility consistent with the Individuals with Disabilities Education Act. Education agencies shall consider eligibility under all disability categories set forth in the Idaho Special Education Manual with the exception of developmental delay, which is an optional category. If an education agency elects to use the developmental delay category, it shall consider developmental delay for students ages three (3) through nine (9) using the eligibility criteria adopted by the Department and set forth in the Idaho Special Education Manual. The total timeline from the date of receipt of written parental consent for an initial evaluation to the date of determination of eligibility for special education and related services must not exceed sixty (60) calendar days, excluding periods when regular school is not in session for five (5) or more consecutive school days, unless all parties agree to an extension. (3-15-22)~~

~~**04. Individualized Education Programs.** Each education agency shall develop an individualized education program (IEP) for each student who is eligible for special education. The IEP shall be implemented as soon as possible after it is developed. The total timeline from the determination that the student needs special education and related services to the date of implementation of the initial IEP shall not exceed thirty (30) calendar days. A new IEP shall be developed at least annually, on or before the date the previous IEP was developed. (3-15-22)~~

~~a. IEP team meetings shall be convened upon reasonable request of any IEP team member at times other than the annual review. If the education agency refuses to convene an IEP team meeting requested by a parent or adult student, the agency shall provide written notice of the refusal. (3-15-22)~~

~~b. Education agencies shall document the attendance of all participants at each IEP team meeting. Any participant who does not agree with an IEP team decision regarding a student's educational program may place a minority report in that student's file. A minority report shall not prevent implementation of an IEP team decision. (3-15-22)~~

- ~~e. The IEP team shall determine the student's placement in the least restrictive environment. (3-15-22)~~
- ~~d. At the discretion of the education agency, an individualized family service plan (IFSP) may be used in place of an IEP if: (3-15-22)~~

 - ~~i. The child is ages three (3) through five (5), and (3-15-22)~~
 - ~~ii. The child's parents are provided with a detailed explanation of the differences between an IFSP and an IEP, and (3-15-22)~~
 - ~~iii. The child's parents provide written consent to use the IFSP, and (3-15-22)~~
 - ~~iv. The IFSP is developed in accordance with IDEA Part B policies and procedures. (3-15-22)~~
 - ~~v. Nothing in this part requires education agencies to develop IFSPs rather than IEPs for three (3) through five (5) year old nor to implement more than the educational components of the IFSP. (3-15-22)~~
- ~~e. When a student who has been determined eligible for special education, as indicated by a current IEP, transfers from one (1) Idaho education agency to another, the student is entitled to continue to receive special education services. The receiving education agency may accept and implement the existing IEP or may convene an IEP team meeting to develop a new IEP. If a new IEP cannot be developed within five (5) school days, or if the education agency wishes to re-evaluate the child, an interim (short term) IEP shall be implemented pending development of the standard IEP. (3-15-22)~~
- ~~f. If a student who is eligible for special education in another state transfers to an Idaho education agency, the Idaho education agency shall request a copy of the student's most recent eligibility documentation and IEP within two (2) school days. Within five (5) school days of receipt of the eligibility documentation and IEP, the Idaho education agency shall determine if it will adopt the existing eligibility documentation and IEP. If the education agency disagrees with the existing eligibility documentation, or if the documentation is not available within a reasonable time period, consent for an initial assessment shall be sought. While the assessment and evaluation is in process, the education agency may implement an interim IEP if the parent or adult student agrees. If the parent or adult student does not agree to an interim IEP, the student shall be placed in general education. (3-15-22)~~
- 05. Procedural Safeguards.** Education agencies will use appropriate procedural safeguards consistent with the Individuals with Disabilities Education Act. (3-15-22)
- ~~a. If a parent or adult student disagrees with an individualized education program (IEP) team's proposed IEP for the student, the parent or adult student may file a written objection to all or parts of the proposed IEP. If the written objection is emailed, postmarked or hand delivered within ten (10) calendar days of the date the parent or adult student receives written notice of the proposed IEP, the proposed change cannot be implemented for fifteen (15) calendar days, or as extended through mutual agreement by the district and the parent or adult student while the parties work to resolve the dispute. Parties may choose to hold additional IEP team meetings which may be facilitated by the State Department of Education (SDE) or request voluntary mediation through the SDE. If these methods fail or are refused, the proposed IEP shall be implemented after fifteen (15) calendar days unless a due process hearing is filed by the parents or adult student, during which time the student shall remain in the current educational placement during the pendency of any administrative or judicial proceeding, unless the district/adult student agree otherwise. The written objection cannot be used to prevent the education agency from placing a student in an interim alternative educational setting in accordance with IDEA discipline procedures, or to challenge an eligibility/identification determination. (3-15-22)~~
- ~~b. Mediation may be requested by an education agency, parent, or adult student, or offered by the State Department of Education at any time. The Department shall screen all such requests to determine appropriateness. Any time a hearing is requested, the Department shall offer mediation using policies and requirements set forth in the Individuals with Disabilities Education Act regulations. If the Department appoints a mediator, the Department shall be responsible for compensating the mediator. All mediation participants will receive~~

~~a copy of the Notification of Mediation Confidentiality form. Attorney fees may not be awarded for a mediation that is conducted prior to a request for a due process hearing. (3-15-22)~~

~~e. The State Department of Education shall administer a single-tiered due process hearing system to resolve disputes between education agencies and parents or adult students. When a due process hearing is requested, the superintendent, special education director, or other agency administrator shall inform the agency's board of trustees or other governing body of the request. The education agency shall immediately notify the Department's Director of Special Education of any request for a due process hearing. Within ten (10) calendar days of a written request for a regular hearing, or within five (5) business days of a written request for an expedited hearing, an impartial hearing officer shall be assigned by the Department. The Department shall maintain a list of trained hearing officers and their qualifications. (3-15-22)~~

~~d. The education agency that is a party to the hearing shall be responsible for compensating the hearing officer and paying for the cost of a verbatim transcript of the hearing. (3-15-22)~~

~~e. Due process hearings shall be conducted pursuant to IDAPA 04.11.01, "Idaho Rules of Administrative Procedure of the Attorney General," Individuals with Disabilities Education Act requirements, and the Idaho Special Education Manual, incorporated by reference in Section 004 of this rule. In case of any conflict between the IDAPA 04.11.01, "Idaho Rules of Administrative Procedure of the Attorney General" and the IDEA, the IDEA shall supersede the IDAPA 04.11.01, and IDAPA 04.11.01 shall supersede the Idaho Special Education Manual. (3-15-22)~~

~~f. The hearing officer shall issue a written decision that includes findings of fact and conclusions of law within forty five (45) calendar days of the date a regular hearing is requested, unless a specific extension of this time line is requested by one (1) of the parties and granted by the hearing officer. The hearing officer shall issue a written decision that includes findings of fact and conclusions of law within twenty (20) calendar days of a written request for an expedited hearing, unless a specific extension of this time line has been granted. An extension of the time line for an expedited hearing shall not exceed an additional twenty five (25) calendar days, and may be granted only if requested by one (1) of the parties and agreed to by both parties. The decision shall be sent to the parent or adult student, the education agency administrator, their respective representatives, and the State Department of Education. (3-15-22)~~

~~g. The hearing officer's decision shall be binding unless either party appeals the decision by initiating a civil action. The hearing officer's decision shall be implemented not later than fourteen (14) calendar days from the date of issuance unless an appeal is filed by a parent or adult student or the decision specifies a different implementation date. An appeal to civil court must be filed within forty two (42) calendar days from the date of issuance of the hearing officer's decision. (3-15-22)~~

~~h. During the hearing the education agency shall provide reasonable accommodations as required by federal and state regulations. Disputes concerning reasonable accommodations shall be referred to the U.S. Department of Education's Americans with Disabilities Act (ADA) Committee for resolution. (3-15-22)~~

~~i. During the pendency of any due process hearing or civil appeal the child's educational placement shall be determined by the Individuals with Disabilities Education Act "stay put" requirements. (3-15-22)~~

~~j. A parent or adult student has the right to an independent educational evaluation (IEE) at public expense if the parent or adult student disagrees with an evaluation obtained by the education agency. Whenever an IEE is at public expense, the criteria under which the evaluation is obtained, including the location of the evaluation and the qualifications of the examiner, shall be the same as the criteria the education agency uses when it initiates an evaluation, to the extent those criteria are consistent with the parent or adult student's right to an IEE. If an education agency has cost as one (1) of the criteria the education agency uses when it initiates an evaluation, the education agency may apply that criteria to independent educational evaluations. However, the parent or adult student has the right to demonstrate that unique circumstances justify an IEE that falls outside the education agency's cost criteria, and if so demonstrated, that IEE shall be publicly funded. A due process hearing may be initiated by the education agency to determine if the evaluation conducted by the education agency is appropriate. If the final decision of a hearing officer, or civil court, if the hearing officer's decision is appealed, is that the evaluation conducted by the education agency is appropriate, the parent or adult student still has the right to an independent educational~~

evaluation, but not at the education agency's expense. (3-15-22)

~~k.~~ Student records shall be managed in accordance with IDEA and Family and Educational Rights and Privacy Act regulations governing security, confidentiality, access, maintenance, destruction, inspection and amendment. (3-15-22)

~~06. Assistive Technology Devices.~~ Education agencies may hold a parent liable for the replacement or repair of an assistive technology device that is purchased or otherwise procured by the education agency if it is lost, stolen, or damaged due to negligence or misuse at home or in another setting outside of school time. (3-15-22)

~~07. Diplomas and Graduation.~~ School districts shall use a regular diploma for students who are eligible for special education at the completion of their secondary program. The transcript serves as a record of individual accomplishments, achievements, and courses completed. A modified or differentiated diploma or certificate may not be used for students who are eligible for special education unless the same diploma or certificate is granted to students without disabilities. If a student is not granted a regular high school diploma or if a regular high school diploma is granted for completing requirements that are not comparable to regular graduation requirements, a student who is eligible for special education is entitled to receive a free appropriate public education through the semester in which the student turns twenty one (21) years of age or until the student completes requirements that are comparable to regular graduation requirements, whichever comes first. (3-15-22)

~~08. Special Education Advisory Panel.~~ The State Superintendent of Public Instruction shall appoint members to serve on the Special Education Advisory Panel. Panel members shall elect annually an individual to serve a one (1) year term as vice chair followed by a one (1) year term as chair. (3-15-22)

109. (RESERVED)

IDAPA 08 – STATE BOARD OF EDUCATION
08.04.01 – RULES OF THE IDAHO DIGITAL LEARNING ACADEMY
DOCKET NO. 08-0401-2401
NOTICE OF RULEMAKING – PROPOSED RULE

AUTHORITY: In compliance with Section 67-5221(1), Idaho Code, notice is hereby given that this agency has initiated proposed rulemaking procedures. The action is authorized pursuant to Article IX, Section 2 of the Idaho Constitution and under Sections 33-5504, 33-5505, 33-5507, and Chapter 55, Title 33, Idaho Code.

PUBLIC HEARING SCHEDULE: Public hearing(s) concerning this rulemaking will be scheduled if requested in writing by twenty-five (25) persons, a political subdivision, or an agency, not later than October 16, 2024.

The hearing site(s) will be accessible to persons with disabilities. Requests for accommodation must be made not later than five (5) days prior to the hearing, to the agency address below.

DESCRIPTIVE SUMMARY: The following is a nontechnical explanation of the substance and purpose of the proposed rulemaking:

The 2024 Legislature reviewed 08.04.01 rule amendments. Concurrent resolutions HCR32 and SCR122 were not in alignment on a single point of revision and therefore none of the proposed amendments passed. Specifically, the House Education Committee rejected the proposed removal of language in subsection 102.03 requiring faculty to contact students within the first 24 hours of class. The Senate Education Committee did not reject this proposed amendment. All other proposed revisions were not contested by either germane committee. IDLA has requested to bring forward in 2025 the same proposed revisions, excluding the section that did not achieve consensus in 2024.

The proposed change will allow IDLA in collaboration with the local education agency (LEA) to determine comprehensive assessment requirements for their students enrolled in Idaho Digital Learning Academy (IDLA) courses. This proposed change reflects similar language in 08.04.01, Section 01 under Accountability recognizing the partnership between IDLA and the local school enrolling the student. The current language specifies a more traditional assessment. The proposed language will provide for a broader definition and allow for portfolios or other demonstrations of learning to serve as the final assessment when deemed appropriate by IDLA and the LEA. This minor adjustment to 08.04.01 recognizes the authority of LEAs. The adjustment to 08.04.01 does not increase regulation.

FEE SUMMARY: The following is a specific description of the fee or charge imposed or increased: NA

FISCAL IMPACT: The following is a specific description, if applicable, of any negative fiscal impact on the state General Fund greater than ten thousand dollars (\$10,000) during the fiscal year resulting from this rulemaking: NA

NEGOTIATED RULEMAKING: Pursuant to Section 67-5220(1), Idaho Code, negotiated rulemaking was conducted. The Notice of Intent to Promulgate Rules - Negotiated Rulemaking was published in the June 5, 2024 Idaho Administrative Bulletin, [Volume 24-6, page 22](#).

INCORPORATION BY REFERENCE: Pursuant to Section 67-5229(2)(a), Idaho Code, the following is a brief synopsis of why the materials cited are being incorporated by reference into this rule: NA

ASSISTANCE ON TECHNICAL QUESTIONS, SUBMISSION OF WRITTEN COMMENTS: For assistance on technical questions concerning the proposed rule, contact Nicholas Wagner at rules@edu.idaho.gov or (208)-488-7586.

Anyone may submit written comments regarding this proposed rulemaking. All written comments must be directed to the undersigned and must be delivered on or before October 23, 2024.

DATED this 23rd day of August, 2024.

Nicholas Wagner
Administrative Rules Coordinator
Idaho State Board of Education
650 W State St.
PO Box 83720
Boise, Idaho 83720-0037
Phone: (208)488-7586, fax: (208)334-2632

THE FOLLOWING IS THE PROPOSED TEXT OF DOCKET NO. 08-0401-2401
(Only Those Sections With Amendments Are Shown.)

08.04.01 – RULES OF THE IDAHO DIGITAL LEARNING ACADEMY

102. ACCOUNTABILITY.

01. Exams. Each IDLA course will require the student to ~~take complete, at the discretion of the LEA,~~ either a comprehensive final exam at an approved site under proctored conditions or a comprehensive final project. (3-15-22)()

02. Student Work and Ethical Conduct. (3-15-22)

a. IDLA will inform students in writing of the consequences of plagiarism. The consequences for plagiarism are set out in the IDLA student handbook which is made available online at all times and is communicated to each student and parent prior to the beginning of each class. IDLA will investigate suspected cases of plagiarism and inform parents, students, and the local school district when a suspected case arises. (3-15-22)

b. Acceptable use and behavior in a distance-learning environment is determined by local school district's policies IDLA students and parents will be informed by the IDLA AUP specifically governing behavior in an online school. IDLA will provide a copy of the IDLA AUP to the Idaho State Board of Education in the IDLA Annual Report. (3-15-22)

c. In a case of violation of the acceptable use policy or other disciplinary issues, IDLA will notify the local school district. The local school district is responsible for the appropriate disciplinary action. IDLA should be notified by the local school district of any disciplinary action resulting from a student's participation in an IDLA course. (3-15-22)

d. The IDLA Director or designee reserves the right to deny disruptive students access to IDLA courses in the future or remove them from participating in an existing course. Appeals to the denial or removal from a course may be made in writing to the IDLA Board of Directors discussing the circumstances for removal or denial. The IDLA Board of Directors will review the appeal and hold a special board meeting to allow the student an opportunity to speak to the issue. The IDLA Board of Directors will issue a final decision within ten (10) days of the board meeting. (3-15-22)

03. Teacher Interaction. IDLA faculty are required to contact students within the first twenty-four (24) hours of class. Contact includes phone, e-mail, web conferencing, or other technological means. IDLA is required to submit periodic progress reports and final course percentages for individual students' grades which are then reported to the local school district for transcription to the student's academic record. (3-15-22)

IDAPA 09 – IDAHO DEPARTMENT OF LABOR

09.01.01 – RULES OF ADMINISTRATIVE PROCEDURE OF THE DEPARTMENT OF LABOR

DOCKET NO. 09-0101-2401 (ZBR CHAPTER REWRITE)

NOTICE OF RULEMAKING – PROPOSED RULE

AUTHORITY: In compliance with Section 67-5221(1), Idaho Code, notice is hereby given that this agency has initiated proposed rulemaking procedures. The action is authorized pursuant to Sections 72-1300 et seq., Idaho Code, Sections 45-600 et seq., 74-106(7), Idaho Code.

PUBLIC HEARING SCHEDULE: Public hearing(s) concerning this rulemaking will be scheduled if requested in writing by twenty-five (25) persons, a political subdivision, or an agency, not later than Oct. 16, 2024.

The hearing site(s) will be accessible to persons with disabilities. Requests for accommodation must be made not later than five (5) days prior to the hearing, to the agency address below.

DESCRIPTIVE SUMMARY: These rules are being presented for authorization as part of the IDOL’s plan to review each rule every 5 years. There are no specific rulemaking changes planned by the IDOL at this time except for evaluation and amendment consistent with the Governor’s [Zero-Based Regulation Executive Order](#). It is anticipated that rulemaking stakeholders will propose and advocate for rulemaking changes as part of the negotiated rulemaking process. The IDOL intends to carefully consider all changes presented by the public and may propose certain changes so long as they are consistent with the rules’ statutory authority and the Governor’s Executive Order. The IDOL will review the documents that are currently incorporated by reference in this rule and update that list as applicable.

FEE SUMMARY: The following is a specific description of the fee or charge imposed or increased: N/A.

FISCAL IMPACT: The following is a specific description, if applicable, of any negative fiscal impact on the state General Fund greater than ten thousand dollars (\$10,000) during the fiscal year resulting from this rulemaking: No fiscal impact.

NEGOTIATED RULEMAKING: Pursuant to Section 67-5220(1), Idaho Code, negotiated rulemaking was conducted. The Notice of Intent to Promulgate Rules - Negotiated Rulemaking was published in the July 3, 2024, Idaho Administrative Bulletin, [Vol. 24-7, page 57-58](#).

INCORPORATION BY REFERENCE: Pursuant to Section 67-5229(2)(a), Idaho Code, the following is a brief synopsis of why the materials cited are being incorporated by reference into this rule: N/A.

ASSISTANCE ON TECHNICAL QUESTIONS, SUBMISSION OF WRITTEN COMMENTS: For assistance on technical questions concerning the proposed rule, contact Darlene Carnopis at 208-696-2380.

Anyone may submit written comments regarding this proposed rulemaking. All written comments must be directed to the undersigned and must be delivered on or before Oct. 23, 2024.

DATED this 30th day of August, 2024.

Darlene Carnopis
Policy Coordinator
Idaho Department of Labor
317 W. 3rd St.
Boise, ID 83702
Phone: (208) 696-2380
Email: darlene.carnopis@labor.idaho.gov

THE FOLLOWING IS THE PROPOSED TEXT OF DOCKET NO. 09-0101-2401
(ZBR Chapter Rewrite)

09.01.01 – RULES OF ADMINISTRATIVE PROCEDURE OF THE DEPARTMENT OF LABOR

000. LEGAL AUTHORITY.

These rules are promulgated under Sections 45-616 and 72-1333(2), Idaho Code. (3-23-22)

001. SCOPE.

These rules govern all procedures for rulemaking, petitions for declaratory rulings, and determinations and appeals pursuant to the Employment Security Law, Title 72, Chapter 13, Idaho Code, and the Claims for Wages Act, Title 45, Chapter 6, Idaho Code, and for other programs administered by the Department unless otherwise specified by law. (3-23-22)

~~002. (RESERVED)~~

~~003. ADMINISTRATIVE APPEALS.~~

~~Administrative appeals from determinations under the Employment Security Law and the Claims for Wages Act may be taken as provided in these rules and applicable provisions of the Employment Security Law and the Claims for Wages Act. (3-23-22)~~

~~002. – 003. (RESERVED)~~

004. PAYMENTS TO THE DEPARTMENT.

Any payment tendered to the Department will be for collection only and will not constitute payment of any amount due until the payment clears the appropriate financial institution. Should the Department incur any additional expense in the payment collection, the expense will be paid by the person who tenders said payment to the Department. (3-23-22)

005. – 009. (RESERVED)

010. DEFINITIONS.

01. Appeals Examiner. A Department hearing officer designated to hear administrative appeals pursuant to the Employment Security Law and the Claims for Wages Act. (3-23-22)

02. Claims for Wages Act. The Claims for Wages Act codified at Title 45, Chapter 6, Idaho Code. (3-23-22)

03. Department. The Idaho Department of Labor. (3-23-22)

04. Determination. Unless the context clearly suggests otherwise, reference to a determination in these rules includes a determination, redetermination, or a revised determination. (3-23-22)

05. Employment Security Law. The Employment Security Law codified at Title 72, Chapter 13, Idaho Code. (3-23-22)

~~011. – 014. (RESERVED)~~

~~015. EXEMPTION FROM ATTORNEY GENERAL ADMINISTRATIVE PROCEDURE RULES FOR CONTESTED CASES.~~

~~Pursuant to Section 67-5206(5), Idaho Code, the procedures contained in Subchapter B, "Contested Cases," of the Idaho Rules of Administrative Procedure of the Attorney General, IDAPA 04.11.01.100 through 04.11.01.799, do not~~

~~apply to appeals within the Department. All appeals within the Department are governed solely by the provisions of the Employment Security Law, the Claims for Wages Act, these rules, and by the applicable federal law governing programs administered by the Department. (3-23-22)~~

~~**016. REASONS FOR EXEMPTION FROM ATTORNEY GENERAL'S ADMINISTRATIVE PROCEDURE RULES.**~~

~~**01. Unemployment Insurance Benefits and Tax Contribution Proceedings.** Sections 72-1361 and 72-1368, Idaho Code, provide that all proceedings to determine the rights to unemployment insurance benefits and tax contribution coverage are exempt from the contested case and judicial review provisions of the Idaho Administrative Procedure Act. Appeals of complaint determinations and other decisions arising within the complaint system or other programs administered by the Department must be determined by the requirements of applicable federal law. Procedures for administrative proceedings and appeals are provided for in the Employment Security Law and these rules. All procedures affecting the rights to benefits and unemployment insurance coverage must be determined solely by the requirements of the Employment Security Law. Such proceedings must be speedy and simple as required by the Federal Unemployment Tax Act and the Social Security Act. The Department determines that it can more adequately meet these requirements through promulgating its own rules rather than relying upon the rules applicable to other state agencies. (3-23-22)~~

~~**02. Claims for Wages Proceedings.** All proceedings to determine claims for wages are exempt from the contested case provisions of the Idaho Administrative Procedure Act pursuant to Section 45-617(2), Idaho Code. Procedures for administrative proceedings and appeals are provided for in the Claims for Wages Act and these rules. (3-23-22)~~

~~**017. (RESERVED)**~~

~~**011. – 017. (RESERVED)**~~

018. DECLARATORY RULING PROCEDURES.

Form and Contents of Petitions for Declaratory Rulings on Applicability of Statutes or Rules. Any person petitioning for a declaratory ruling on the applicability of a statute or Department rule must comply with this rule. (3-23-22)

01. Form of Petition. The petition must: identify the petitioner and state the petitioner's interest in the matter; state the declaratory ruling that the petitioner seeks; and indicate the statute, or rule, and the factual allegations upon which the petitioner relies to support the petition. (3-23-22)

02. Legal Assertions. Citations of cases and/or statutory provisions may accompany the legal assertions in a petition for a declaratory ruling. (3-23-22)

03. Filing Petition. A petition for a declaratory ruling on applicability of statutes or rules must be filed with the Director of the Department at 317 Main Street, Boise, Idaho 83735. (3-23-22)

~~**04. Disposition of Petitions for Declaratory Rulings.** When a petition is received in the form and content required by these rules, the Director or the Director's designee will review the petition contents and request additional information from the petitioner, if necessary, and thereafter rule on the petition and notify the petitioner and any other interested parties in writing of the ruling. (3-23-22)~~

~~**019. – 024~~5~~. (RESERVED)**~~

~~**025. WAGE CLAIMS PROCEDURES.**~~

~~Administrative procedures for wage claims filed with the Department pursuant to the Claims for Wages Act are governed by these rules and Section 45-617, Idaho Code. (3-23-22)~~

026. DISMISSAL OF WAGE CLAIMS FOR LACK OF PROSECUTION.

Wage claimants have a responsibility to seek prompt adjudication of their claims. The Department may dismiss, without prejudice, wage claims when claimants fail to respond within thirty (30) days to written notice from the Department that additional action is required on their part to prosecute their claim. The thirty (30) day period for a

response begins the date the notice is mailed to the wage claimant's last known address. Mailed responses are deemed received the date they are postmarked. A wage claim dismissed for lack of prosecution may be refiled with the Department subject to limitations of Sections 45-614 and 45-617(1), Idaho Code. (3-23-22)

027. WAGE CLAIM AND EMPLOYMENT SECURITY LAW DETERMINATIONS.

01. Determinations and Time for Filing Appeals. Department determinations under the Claims for Wages Act and Employment Security Law must be in writing and contain provisions advising the interested parties of their right to appeal the determination within fourteen (14) days from the date of mailing, or the date of electronic transmission to an electronic-mail address approved by the Department, in accordance with Sections 45-617(5), 72-1361 and 72-1368(5), Idaho Code, and must contain and clearly identify the mailing address, fax number and electronic address for filing an appeal. The date of mailing or service indicated on the determination shall be deemed the date of service of the determination. A determination is final unless, within fourteen (14) days after notice, as provided in Sections 45-617(5) and 72-1368(5), Idaho Code, an appeal is filed by an interested party with the Department in accordance with these rules. If an appeal from a wage claim determination is not timely filed, the amount awarded by a final determination will be immediately due and payable to the Department. (3-23-22)

~~**02. Appeals Heard By Appeals Examiners.** Appeals from wage claim and Employment Security Law determinations will be heard by an appeals examiner in accordance with the Claims for Wages Act, the Employment Security Law, and these rules. (3-23-22)~~

03. Computation of Time. In computing any time period prescribed or allowed by the Employment Security Law or the Claims for Wages Act, the day of the act, event, or default is not to be included. Saturdays, Sundays, and holidays will be counted during the period, except, if the last day of the period is a Saturday, Sunday, or legal holiday, the period extends to the next business day following the Saturday, Sunday, or legal holiday. (3-23-22)

028. – 034. (RESERVED)

035. APPEALS TO APPEALS EXAMINER – FORM AND MANNER OF FILING OF NOTICES OF APPEAL.

01. Form of Notices of Appeal. Any appeal taken to an appeals examiner pursuant to the Employment Security Law and the Claims for Wages Act must be in writing, signed by an interested party, the appellant or representative, and contain words that, by fair interpretation, request the appeal process for a specific determination or other decision of the Department. (3-23-22)

02. Filing of Notices of Appeal. To appeal a determination or other decision of the Department, interested parties must follow these rules and the instructions on the determination or other decision being appealed. If an appeal is delivered personally, the personal delivery date will be noted on the appeal and deemed the date of filing. A faxed or electronically transmitted appeal will be deemed filed on the date received by the Department (mountain time) or, if received on a weekend or holiday, the next business day. If mailed, the appeal will be deemed filed on the date of mailing as determined by the postmark on the envelope containing the appeal, unless a party establishes by a preponderance of the evidence that but for error by the U.S. Postal Service, the envelope would have been postmarked within the period for timely appeal. If such a postal error is established, the appeal will be deemed to be timely filed. Ref. Section 72-1368(6), and Section 45-617, Idaho Code. (3-23-22)

~~**036. DATE OF SERVICE OF DETERMINATIONS.**~~

~~The date indicated on determinations and decisions as the “Date of Service” or “Date of Mailing” will be presumed to be the date the document was deposited in the United States mail, or the date the document was electronically transmitted to an electronic mail address approved by the Department pursuant to Section 72-1368(5), Idaho Code, unless shown otherwise by a preponderance of competent evidence. (3-23-22)~~

~~**036. (RESERVED)**~~

037. EFFECT OF DELAY OR ERROR OF POSTAL SERVICE OR DEPARTMENT.

01. Department Determinations. If a party establishes by a preponderance of the evidence that

because of delay or error by the U.S. Postal Service, or because of error on the part of the Department, a determination was not delivered to the party's last known address, or transmitted electronically to the party's electronic-mail address approved by the Department, within fourteen (14) days of the date of mailing or service indicated on the determination, the period for filing a timely appeal extends to fourteen (14) days from the date of actual notice. (3-23-22)

02. Decisions of the Appeals Examiner. If a party establishes by a preponderance of the evidence that, because of delay or error by the U.S. Postal Service, or because of error on the part of the Department, a decision by an appeals examiner was not delivered to the party's last known address, or transmitted electronically to the party's electronic-mail address approved by the Department, within the time periods prescribed by the Employment Security Law or the Claims for Wages Act for filing an application for rehearing or an appeal to the Industrial Commission, as the case may be, then: (3-23-22)

a. For an application for rehearing that must be filed within ten (10) days of notice of service of a decision, the period for filing a timely application for rehearing extends to ten (10) days from the date of actual notice; and (3-23-22)

b. For an appeal to the Industrial Commission that must be filed within fourteen (14) days of notice of service of a decision, the period for filing a timely appeal extends fourteen (14) days from the date of actual notice. Ref. Section 72-1368 (5) and (6) and Section 45-617(7), Idaho Code. (3-23-22)

038. DISMISSAL IF FILING IS LATE.

Where it appears any appeal (request for hearing) to the appeals examiner, or claim, or any other request or application, was not filed within the time period prescribed for filing, it will be dismissed on such grounds; provided, however, before or after such dismissal, the adversely affected interested party will be notified and given an opportunity to show that such appeal, claim for review, petition, or other request was timely. If it is found that such appeal, claim for review, petition, or other request or application was timely, the matter will be decided on the merits. Copies of a decision under this section will either be given, mailed, or electronically transmitted to an electronic-mail address approved by the Department pursuant to Section 72-1368(5), Idaho Code, to all interested parties, together with a clear statement of right of appeal or review. Ref. Section 72-1368 and Section 45-617, Idaho Code. (3-23-22)

039. – 044. (RESERVED)

045. CONDUCT OF APPEALS HEARING.

Upon request for appeal, a hearing before an appeals examiner will be set. Written notice of the time and place of the hearing will be mailed or electronically transmitted to each interested party not less than seven (7) days prior to the hearing date. (3-23-22)

01. Telephone Hearings. Hearings will be held by telephone unless, at the sole discretion of the appeals examiner, a personal hearing should be set. In deciding the manner in which to conduct the hearing, the appeals examiner will consider factors, including but not limited to the desires of the parties, possible delay and expense, the burden of proof, the complexity of the issues, and the number and location of witnesses. (3-23-22)

02. Continuance. The appeals examiner may postpone or continue a hearing for good cause on the examiner's own motion or that of any party, before a hearing is concluded. The appeals examiner may dismiss an appeal for good cause, such as abandonment of the appeal. (3-23-22)

03. Rehearing. An application for rehearing will be in writing and filed in person or postmarked within ten (10) days after the appeals examiner's decision is served. (3-23-22)

04. No Appearance Hearings. If no party appears to present additional evidence, a decision may be based on the existing record. For this purpose, the existing record will consist of documents maintained by the Department in the ordinary course of adjudicating the issues in the case, copies of which are provided to the parties with the notice of hearing. (3-23-22)

05. Exhibits and Recordings. Hearing exhibits and recordings may be destroyed, reused, or otherwise disposed of after the expiration of the time period for appeal from the decisions of the appeals examiner. (3-23-22)

~~06. Subpoenas. After determining a subpoena of a witness or records is necessary and reasonable, the appeals examiner will issue the subpoena, which may be served by mail or in person. (3-23-22)~~

~~07. Failure to Respond to Subpoena. If a person fails to respond to a subpoena issued by mail, the appeals examiner will proceed with the scheduled hearing and determine, after hearing available testimony, whether the subpoena is still necessary and reasonable. If so, the hearing will be continued and a second subpoena will be issued and personally served. (3-23-22)~~

~~08. Witness Fees. Individuals who attend hearings before the appeals examiner as subpoenaed witnesses, not parties, are entitled to receive a fee of seven dollars and fifty cents (\$7.50) for each day or portion thereof for attendance. In no case will a witness be paid more than seven dollars and fifty cents (\$7.50) for any one (1) day. Subpoenaed witnesses are entitled to mileage expense at the current allowable mileage reimbursement rate as determined by the Idaho State Board of Examiners. For appeals under the Employment Security Law, such witness fees and mileage expenses will be paid from the Employment Security Administration fund. Under no circumstances will interested parties to a hearing be granted witness fees or mileage expenses. Mileage fees are not allowed for vicinity travel. (3-23-22)~~

~~09. Undecided Issues. When it is apparent that there is no prior ruling on an issue that must be decided under the Act, the appeals examiner may hear and decide the issue. (3-23-22)~~

~~10. Type of Hearing. The proceeding before an appeals examiner will be a hearing “de novo” or original hearing and not solely a review proceeding. Ref. Sec. 72-1368(6) and Sec. 45-617(7), Idaho Code. (3-23-22)~~

~~11. Role of Appeals Examiner. The appeals examiner will function as a fact finder and not solely as a judge. The appeals examiner will have the responsibility of developing all the evidence that is reasonably available. Ref. Sec. 72-1368(6) and Sec. 45-617(7), Idaho Code. (3-23-22)()~~

~~12. Order of Witnesses. The appeals examiner, in the exercise of reasonable discretion, will direct the order of witnesses and develop evidence in a logical and orderly manner to move the hearing along as expeditiously as possible. Ref. Sec. 72-1368(6) and Sec. 45-617(7), Idaho Code. (3-23-22)()~~

~~13. Evidence. The appeals examiner may exclude evidence that is irrelevant, unduly repetitious, or excludable on constitutional or statutory grounds, or on the basis of any evidentiary privilege provided by statute or recognized in the courts of this state. All other evidence may be admitted if it is of a type commonly relied upon by prudent persons in the conduct of their affairs. Ref. Sec. 72-1368(6) and Sec. 45-617(7), Idaho Code. (3-23-22)()~~

~~14. Disruptive Individuals. The appeals examiner may exclude disruptive individuals from the hearing or may postpone the hearing if the integrity of the proceedings is being compromised. If an interested party is excluded, they will be provided a copy of the recording of the proceedings and given an opportunity to submit written evidence and argument prior to the issuance of the decision and the opposing party will be given an opportunity to respond. Ref. Sec. 72-1368(6) and Sec. 45-617(7), Idaho Code. (3-23-22)()~~

~~15. Challenge of General Knowledge. If judicially cognizable facts or general, technical, or scientific facts within the appeals examiner's specialized knowledge are used in the decision, the parties will be given an opportunity to challenge them at the time of the hearing, or at the time of the issuance of the decision. Ref. Sec. 72-1368(6) and Sec. 45-617(7), Idaho Code. (3-23-22)()~~

~~16. Closing Arguments. Closing arguments will be limited to five (5) minutes for each party unless the appeals examiner grants an exception. Ref. Sec. 72-1368(6) and Sec. 45-617(7), Idaho Code. (3-23-22)()~~

046. COMMUNICATION WITH APPEALS STAFF.

No party involved in an appeal may communicate, either directly or indirectly, with appeals examiners, the Chief of the Appeals Bureau, or clerical staff of the Appeals Bureau, regarding any issue of fact or law relevant to an appeal, unless all parties involved have been provided notice and an opportunity to participate in such communication. No person acting on behalf of any party, including the Idaho Department of Labor, may attempt to influence the

disposition of an appeal through such communications. No appeals examiner may knowingly cause a communication prohibited by this section to be made. (3-23-22)

01. Prohibition of Ex Parte Contacts. The prohibition on ex parte contacts contained in this rule applies from the time an appeal is filed pursuant to IDAPA 09.01.01.025 or IDAPA 09.01.01.027 until the appeal becomes final and conclusive pursuant to Sections 72-1368 and 45-617, Idaho Code. (3-23-22)

02. Issues of Fact. As used in this rule, the term “issue of fact or law relevant to an appeal” includes any matter relating to the merits of an appeal but does not include questions of appeals procedure or case status inquiries. Parties may not direct questions of appeals procedure or case status inquiries to the appeals examiner assigned to their case but rather to other appeals examiners, the Chief of the Appeals Bureau (unless he or she is functioning as the appeals examiner in the case), or to clerical staff of the Appeals Bureau. (3-23-22)

03. Reporting Prohibited Contacts. An appeals examiner or other Appeals Bureau employee who receives a communication prohibited by this rule must place in the record of the case all such written communications or a memorandum stating the substance of all such oral communications. The Appeals Bureau must send a full copy of the communication to other interested parties to the appeal and allow an appropriate time for the parties to respond. (3-23-22)

047. – 059. (RESERVED)

060. INDUSTRIAL COMMISSION REVIEW OF APPEALS EXAMINER DECISIONS.

01. Claim for Review Under the Employment Security Law. A claim for review of the appeals examiner's decision, as provided in Section 72-1368, Idaho Code, must be made in writing, signed by the person claiming the review or by his attorney or agent, and filed with the Idaho Industrial Commission in accordance with rules adopted by the Commission. Ref. Sec. 72-1368(7) Idaho Code. (3-23-22)

02. Transcripts. Upon receipt of a notice that a claim for review has been filed with the Industrial Commission, a true and correct transcript of the recorded proceedings must be prepared if ordered by the Commission. Copies of transcripts or recording of the proceedings, together with exhibits received in the case, must be transmitted by the Department to the Commission and provided to all interested parties without charge. (3-23-22)

061. – 064. (RESERVED)

~~**065. JUDICIAL REVIEW OF WAGE CLAIM DECISIONS.**~~

~~A claimant or employer aggrieved by a final decision of the appeals examiner in a wage claim proceeding may seek judicial review of the decision pursuant to Title 67, Chapter 52, Idaho Code, and Section 45-619, Idaho Code, by timely filing a petition for judicial review in a court of competent jurisdiction. The Department is not an aggrieved party for purposes of any judicial review proceeding and will not be made a party in any petition for judicial review. The proper parties in a petition for judicial review are the claimant and the employer. (3-23-22)~~

~~**0665. – 999. (RESERVED)**~~

IDAPA 09 – IDAHO DEPARTMENT OF LABOR
09.01.30 – UNEMPLOYMENT INSURANCE BENEFITS ADMINISTRATION RULES
DOCKET NO. 09-0130-2401 (ZBR CHAPTER REWRITE)
NOTICE OF RULEMAKING – PROPOSED RULE

AUTHORITY: In compliance with Section 67-5221(1), Idaho Code, notice is hereby given that this agency has initiated proposed rulemaking procedures. The action is authorized pursuant to Sections 72-1300 et seq., Idaho Code, Sections 45-600 et seq., 74-106(7), Idaho Code.

PUBLIC HEARING SCHEDULE: Public hearing(s) concerning this rulemaking will be scheduled if requested in writing by twenty-five (25) persons, a political subdivision, or an agency, not later than Oct. 16, 2024.

The hearing site(s) will be accessible to persons with disabilities. Requests for accommodation must be made not later than five (5) days prior to the hearing, to the agency address below.

DESCRIPTIVE SUMMARY: These rules are being presented for authorization as part of the IDOL’s plan to review each rule every 5 years. There are no specific rulemaking changes planned by the IDOL at this time except for evaluation and amendment consistent with the Governor’s [Zero-Based Regulation Executive Order](#). It is anticipated that rulemaking stakeholders will propose and advocate for rulemaking changes as part of the negotiated rulemaking process. The IDOL intends to carefully consider all changes presented by the public and may propose certain changes so long as they are consistent with the rules’ statutory authority and the Governor’s Executive Order. The IDOL will review the documents that are currently incorporated by reference in this rule and update that list as applicable.

FEE SUMMARY: The following is a specific description of the fee or charge imposed or increased: N/A.

FISCAL IMPACT: The following is a specific description, if applicable, of any negative fiscal impact on the state General Fund greater than ten thousand dollars (\$10,000) during the fiscal year resulting from this rulemaking: No fiscal impact.

NEGOTIATED RULEMAKING: Pursuant to Section 67-5220(1), Idaho Code, negotiated rulemaking was conducted. The Notice of Intent to Promulgate Rules - Negotiated Rulemaking was published in the July 3, 2024, Idaho Administrative Bulletin, [Vol. 24-7, page 59-60](#).

INCORPORATION BY REFERENCE: Pursuant to Section 67-5229(2)(a), Idaho Code, the following is a brief synopsis of why the materials cited are being incorporated by reference into this rule: N/A.

ASSISTANCE ON TECHNICAL QUESTIONS, SUBMISSION OF WRITTEN COMMENTS: For assistance on technical questions concerning the proposed rule, contact Darlene Carnopis at 208-696-2380.

Anyone may submit written comments regarding this proposed rulemaking. All written comments must be directed to the undersigned and must be delivered on or before Oct. 23, 2024.

DATED this 30th day of August, 2024.

Darlene Carnopis
Policy Coordinator
Idaho Department of Labor
317 W. 3rd St.
Boise, ID 83702
Phone: (208) 696-2380
Email: darlene.carnopis@labor.idaho.gov

THE FOLLOWING IS THE PROPOSED TEXT OF DOCKET NO. 09-0130-2401
(ZBR Chapter Rewrite)

09.01.30 – UNEMPLOYMENT INSURANCE BENEFITS ADMINISTRATION RULES

000. LEGAL AUTHORITY.

These rules are promulgated under Section 72-1333, Idaho Code. (3-23-22)

001. SCOPE.

These rules govern claims for unemployment insurance benefits. (3-23-22)

002. ADMINISTRATIVE APPEALS.

Administrative appeals under this chapter are governed by Section 72-1368, Idaho Code and IDAPA 09.01.01, "Rules of Administrative Procedure of the Department of Labor." (3-23-22)

003. -- 009. (RESERVED)

010. DEFINITIONS.

~~01. **Additional Claim.** An initial claim made after a period of employment subsequent to a new claim in the same benefit year. (3-23-22)~~

021. Average Annual Wage. For the purpose of determining the taxable wage base, under Section 72-1350(1), Idaho Code, the average annual wage is computed by dividing that calendar year's total wages in covered employment, excluding State government and cost reimbursement employers, by the average number of workers in covered employment for that calendar year as derived from data reported to the Department of Labor by covered employers. (3-23-22)

~~032. **Average Weekly Wage.** For the purpose of establishing the maximum weekly benefit amount, under Section 72-1367(2)(a), Idaho Code, the average weekly wage is computed by dividing the total wages paid in covered employment (including State government and cost reimbursement employers) for the preceding calendar year, as computed from data reported to the Department of Labor by covered employers, by the monthly average number of workers in covered employment for the preceding calendar year and then dividing the resulting figure by fifty-two (52). (3-23-22)~~

~~043. **Central Claims Office.** A claims office designated by the director, where unemployment claims throughout the state are processed. (3-23-22)~~

~~05. **Chargeability Determination.** A determination issued with respect to whether a covered employer's account will be charged for benefits paid on a claim. (3-23-22)~~

~~06. **Claim.** An application for unemployment insurance or "benefits." (3-23-22)~~

~~07. **Continued Claim.** An application for waiting week credit or for benefits for specific compensable weeks. (3-23-22)~~

084. Corporate Officer. Any individual empowered in good faith by stockholders or directors in accordance with the corporation's articles of incorporation or bylaws to discharge the duties of a corporate officer. (3-23-22)

095. Fraud Overpayment. An established overpayment resulting from a determination that the claimant willfully made a false statement or willfully failed to report a material fact in order to obtain benefits. Ref. Sec. 72-1369, Idaho Code. (3-23-22)

~~1406.~~ **Full-Time Employment.** A week of full-time employment is one where the claimant worked what are customarily considered full-time hours for that industry or where the earnings were more than one and one half (1-1/2) times his weekly benefit amount. (3-23-22)

~~1407.~~ **Initial Claim.** The first claim for benefits made by an unemployed individual during a continuous period of unemployment. An initial claim may be either new or additional. (3-23-22)

~~1408.~~ **Interstate Claim.** A claim filed by a worker who resides in a state other than the state (or states) in which he has earned wages in covered employment. (3-23-22)

~~1409.~~ **Intrastate Claim.** A claim filed by a worker who resides in Idaho and has earned wages within or as federal wages assigned to Idaho. (3-23-22)

~~14.~~ **Material.** A fact is material if it is relevant to a determination of a claimant's right to benefits. All information a claimant is asked to provide when applying for unemployment benefits or when making a continued claim report is material and relevant to a determination of a claimant's right to benefits. To be considered material, the fact need not actually affect the outcome of an eligibility determination. Ref. Section 72-1366, Idaho Code. (3-23-22)

~~150.~~ **Monetary Determination.** A determination of eligibility which lists a claimant's base period employer(s) and wages and establishes, if the claimant is eligible, his benefit year, his weekly benefit amount, and his total benefit amount. (3-23-22)

~~16.~~ **New Claim.** The first initial claim made in a benefit year. (3-23-22)

~~17.~~ **Non-Fraud Overpayment.** Any established overpayment other than an overpayment resulting from a determination that a claimant made a false statement or willfully failed to report a material fact in order to obtain benefits. Ref. Sec. 72-1369, Idaho Code. (3-23-22)

~~181.~~ **Non-Monetary Determination.** A determination issued by a claims examiner with respect to the personal eligibility conditions of a claimant. (3-23-22)

~~19.~~ **Tolerance Amount.** A tolerance of four dollars and ninety nine cents (\$4.99) connection with the recovery of overpayments and at the discretion of the Director, overpayments for this amount or less may be compromised. Ref. Sec. 72-1369, Idaho Code. (3-23-22)

011. -- 099. (RESERVED)

100. ABLE TO WORK.

"Able to work" is the physical and mental ability to perform work under conditions ordinarily existing during a normal workweek. It does not mean that a person must be able to perform work in his customary occupation or the same kind of work he last performed. Ref. Sec. 72-1366(4), Idaho Code. (3-23-22)

01. Able to Perform Some Type of Work. A person must be able to perform work of some type for which he can qualify at the time he files an initial claim for unemployment insurance. (3-23-22)

02. Able to Work Part-Time. A person who is able to work only part of the workday or part of the workweek is not considered "able to work" for the purposes of Section 72-1366(4), Idaho Code. This rule does not apply to claimants who establish eligibility under Section 150 of these rules, "Claimants with Disabilities." (3-23-22)

03. Disability Compensation. A claimant's receipt of disability compensation does not in itself establish that he is unable to work or unavailable for work, even though the payee has been declared totally disabled. (3-23-22)

04. Illness Provision. A person who claims benefits under the illness provision must remain available for local office job referral; however, he may leave the area for treatment of his illness and continue to be eligible under the illness provision. (3-23-22)

05. Illness Provision as Applied to Transitional or Reopened Claim. The illness provision will continue to apply even though the current benefit year has ended and a transitional claim is filed the following year or the claim is reopened after a period of not filing with no intervening employment. (3-23-22)

06. Withdrawing from Labor Market Because of Illness. A claimant who withdraws from the labor market because of illness or injury prior to filing a claim is not eligible until he is able and available for work. (3-23-22)

101. -- 124. (RESERVED)

125. ALIEN ELIGIBILITY.

01. Benefit Eligibility. To be eligible for benefits, an alien must fall within one (1) of the following three (3) categories at the time the work on which the claim is based was performed and at the time benefits are claimed, the alien must have current, valid authorization to work from the U.S. Department of Homeland Security in order to meet the continuing eligibility requirement of being able and available to work (unless the alien claimant is a Canadian resident who is claiming benefits under the Interstate Benefit Payment Plan, in which case the claimant must satisfy only Canadian availability requirements). Ref. Sec. 72-1366(4), (19), Idaho Code. (3-23-22)

a. Permanent Residence. Aliens who have been lawfully admitted to the United States as “immigrants” and those whose status has been adjusted from that of “non-immigrant” under the Immigration and Nationality Act. Evidence of this status is the Alien Registration Receipt Card, or “green card,” issued to each lawful permanent resident by the U.S. Department of Homeland Security. (3-23-22)

b. Performing Services. “Lawfully present for purposes of performing services” includes three (3) groups of aliens: (3-23-22)

i. Canadian and Mexican residents who commute daily or seasonally and are authorized to work in the United States; (3-23-22)

ii. Legally-admitted non-immigrants who are granted a status by the U.S. Department of Homeland Security which authorizes them to work in the United States during their stay; and (3-23-22)

iii. Other aliens with U.S. Department of Homeland Security authorization to work in the United States regardless of their status. (3-23-22)

c. Permanently Residing Under Color of Law. The category of individuals who are “permanently residing in the United States under color of law” includes the following groups of aliens: (3-23-22)

i. Refugees, asylees, and parolees, as identified in the Immigration and Nationality Act; (3-23-22)

ii. Aliens presumed by the U.S. Department of Homeland Security to be lawfully admitted for permanent residence; and (3-23-22)

iii. Aliens who, after review of their particular circumstances under U.S. Department of Homeland Security statutory or regulatory procedures, have been granted a status which allows them to remain in the United States for an indefinite period of time. For informal U.S. Department of Homeland Security action to authorize an alien’s residence under “color of law,” the U.S. Department of Homeland Security must know of the alien’s presence, and must provide the alien with official, documented assurance that enforcement of deportation is not planned. (3-23-22)

126. -- 149. (RESERVED)

150. CLAIMANTS WITH DISABILITIES.

An individual with a disability under the Americans with Disabilities Act (2008) (as defined at 29 C.F.R. Sec 1630.2(g)), and whose disability prevents the claimant from working full time or during particular shifts is not

deemed unable to work or unavailable for work for so long as the claimant is able to perform some work and remains available for work to the full extent of his ability. (3-23-22)

01. Availability Requirement. A qualified claimant with a disability who is able to work with or without a reasonable accommodation will be considered as having complied with the requirement of being available for work provided the claimant is willing to work the maximum number of hours the claimant is able to work. (3-23-22)

02. Burden of Proof. Claimant has the burden of proving eligibility under this provision with competent evidence. (3-23-22)

03. Additional Eligibility Requirements. Qualified claimants with disabilities must meet all other eligibility requirements, including the illness provision of Section 100 of these rules. (3-23-22)

151. -- 174. (RESERVED)

175. AVAILABLE FOR WORK.

“Available for work” is a state of mind that encompasses a readiness and willingness to work, and a desire to find a job, including the possibility of marketing one’s services in the claimant’s area of availability. There must remain a reasonable possibility of a claimant finding and obtaining, or being referred and hired for, suitable work. Ref. Sec. 72-1366(4), Idaho Code. (3-23-22)

01. Availability Requirements. The type of work for which the claimant is available must exist in the claimant’s area to the extent that a normal unemployed person would generally find work within a reasonable period of time. (3-23-22)

~~**02. Child Care.** Child care must be arranged so as not to restrict a claimant’s availability for work or for seeking work. (3-23-22)~~

~~**032. Compelling Personal Circumstances.** For the purposes of this rule, compelling personal circumstances are defined as: (3-23-22)~~

~~a. A situation in which the claimant required the assistance of emergency response personnel; (3-23-22)~~

~~b. The serious illness, death, or funeral of an immediate family member; or (3-23-22)~~

~~c. The wedding of the claimant or an immediate family member. (3-23-22)~~

~~d. Under this rule, “immediate family member” means a claimant's spouse, child, foster child, parent, brother, sister, grandparent, grandchild, or the same relation by marriage. (3-23-22)~~

~~e. For the purposes of this rule, “workweek” is defined: (3-23-22)~~

~~i. Code ~~R, U, or X~~ **Attached**. The claimant's normal work week as defined by the employer. (3-23-22)()~~

~~ii. Code ~~B or C~~ **Workseeking**. Monday through Friday, 8 a.m.-5 p.m. (3-23-22)()~~

~~iii. Code ~~D~~ **Approved Training**. Regular class hours. (3-23-22)()~~

~~f. Claimant work availability requirements are waived on Independence Day, Thanksgiving Day, Christmas Day, and New Year's Day. (3-23-22)~~

~~**043. Conscientious Objection.** No person may be held to be unavailable for work solely because of religious convictions not permitting work on a certain day. (3-23-22)~~

054. Contract Obligation. A person who is bound by a contract that prevents him from accepting other employment is not eligible for benefits. (3-23-22)

065. Distance to Work. A claimant seeking work must be willing to travel the distance normally traveled by other workers in his area and occupation. (3-23-22)

~~**07. Domestic Circumstances.** A claimant is not eligible for benefits if domestic circumstances take precedence over the claimant's availability for work or for seeking work. (3-23-22)~~

~~**08. Equipment.** Claimants will be required to provide necessary tools or equipment in certain occupations. The lack of these tools or equipment will directly affect a claimant's availability for work, unless he will accept other work. (3-23-22)~~

096. Evidence. A claimant is responsible for providing proof of his availability for work and for seeking work if his availability is questioned or proof is required by these rules. (3-23-22)

~~**10. Experience or Training.** A claimant is expected to be available for work consistent with his past experience or training, provided there is no change in his ability to perform that work. (3-23-22)~~

~~**107. Full-Time/Part-Time Work.** An individual who restricts availability to part-time work pursuant to Section 72-1366(4)(c), Idaho Code, is fully employed and ineligible to receive benefits if the individual works hours comparable to the part-time work experience in their base period. A claimant must be available for a full workweek and a full, normal workday unless the claimant establishes: (3-23-22)~~

~~**a.** The majority of weeks worked during claimant's base period were for less than full-time work, which is established where the total base period wages divided by claimant's last regular rate of pay does not exceed two thousand seventy-nine (2079) hours; or (3-23-22)~~

~~**b.** Eligibility under Section 150 of these rules, "Claimants with Disabilities." (3-23-22)~~

~~**1208. Incarceration/Work Release.** A claimant who is incarcerated for any part of the workweek is not eligible for benefits for that week, unless the claimant can establish he has work release privileges which would provide him a reasonable opportunity to meet his work search requirements and obtain full-time employment. (3-23-22)~~

~~**1309. Jury Duty/Subpoenas.** A claimant serving on jury duty or subpoenaed is excused from the availability and work-seeking requirements of the law for that time period, and may refuse work that would commence during that time period. (3-23-22)~~

~~**14. Licensing or Government Restrictions.** A claimant prohibited by law from engaging in certain work must be available for other employment to be eligible for benefits. (3-23-22)~~

~~**150. Moving to Remote Area.** A claimant who moves to a remote locality where there is very little possibility of obtaining work will be ineligible for benefits. (3-23-22)~~

~~**161. Public Official.** A public official who receives pay and performs "full-time" service is not unemployed or eligible for benefits. Part-time officials, even though receiving pay, may be considered available for work the same as any other individual employed on a part-time basis. Ref. Sec. 72-1312(1). (3-23-22)~~

~~**172. Public Service.** Performing public service, including voluntary non-remunerated service, does not disqualify an individual for benefits as long as he is meeting the availability and work-seeking requirements. (3-23-22)~~

~~**183. Restricting Work to Within the Home.** A claimant who restricts his availability to only work done within the home which severely limits the work available to him is ineligible for benefits. (3-23-22)~~

~~**194. School Attendance or a Training Course.** A person who is attending school or a training course~~

may be eligible for benefits if the attendance does not conflict in any way with that person's availability for work or for seeking work and if he will discontinue attendance upon receipt of an offer of employment that creates a conflict between employment and the schooling or training. (3-23-22)

2015. Temporary Absence from Local Labor Market to Seek Work. All claimants, regardless of their attachment to an industry or employer, must meet the same standard of remaining within their local labor market area during the workweek in order to be considered available for work, unless the primary purpose of a temporary absence is to seek work in another labor market. Claimants otherwise eligible to receive benefits while participating in an approved training program or course are not deemed ineligible when the training or course occurs outside of their local labor market due to the unavailability of similar programs or courses within their local labor market. (3-23-22)

a. To remain eligible for benefits, claimants will remain within the state, territory, or country included in the USDOL Interstate Benefit Payment Plan. (3-23-22)

~~**21. Time.** (3-23-22)~~

~~**a.** Time Restrictions. A claimant may not impose restrictions on his time, including either hours of the day or days of the week, which will limit his availability to seek or accept suitable work. (3-23-22)~~

~~**b.** Shift Restrictions. A claimant who restricts his availability to a single shift may not be fully available for work if the restriction significantly reduces his chances of becoming employed. (3-23-22)~~

~~**22. Transportation Difficulties.** Lack of transportation is not a bona fide reason for a claimant to fail to be available for or to seek work. Transportation is the responsibility of the claimant. (3-23-22)~~

2316. Unreasonable Restrictions on Working Conditions. A claimant who places unreasonable restrictions on working conditions so as to seriously hinder his availability and search for work is ineligible for benefits. (3-23-22)

2417. Vacation. A person on a vacation approved by his employer during time when work is available is not eligible for benefits. (3-23-22)

2518. Wages. A claimant is eligible for benefits if the wages or other conditions of available work are substantially less favorable to the claimant than those prevailing for similar work in the local area. Ref. Sec. 72-1366(7)(b), Idaho Code. (3-23-22)

a. Demanding Higher Wages. A claimant is ineligible for benefits if he unduly restricts his availability for work by insisting on a wage rate that is higher than the prevailing wage for similar work in that area. (3-23-22)

b. Prior Earnings. The claimant's prior earnings and past experience are considered in determining whether he is available for suitable work. (3-23-22)

2619. Waiver of Two-Year Training Limitation. For purposes of approving a waiver of the two (2) year limitation on school or training courses, specified by Idaho Code Section 72-1366(8)(c)(ii), for claimants who lack skills to compete in the labor market, the following criteria must be met: (3-23-22)

a. Financial Plan. The claimant must demonstrate a workable financial plan for completing the school or training course after his benefits have been exhausted. (3-23-22)

b. Demand for Occupation. The claimant must establish there is a demand for the occupation in which the claimant will be trained. A "demand occupation" is one in which work opportunities are available and there is not a surplus of qualified applicants. (3-23-22)

c. Duration of Training. At the time that the claimant applies for the waiver, the duration of the school or training course is no longer than two (2) years to completion. (3-23-22)

~~**d.** Denial. No claimant will be denied a waiver of the two (2) year limitation on school or training~~

~~because the claimant is already enrolled or participating in the school or training at the time he requests the waiver.~~
(3-23-22)

176. -- 199. (RESERVED)

200. CANCELING CLAIMS.

Upon the written request of a claimant, a claim may be canceled at any time, provided that the claimant did not misrepresent or fail to report a material fact in making the claim and the claimant has repaid any benefits received on the claim, unless the benefits received will be offset from a new claim the claimant is filing. Ref. Sec. 72-1327A, Idaho Code. (3-23-22)

201. -- 224. (RESERVED)

225. DECEASED CLAIMANTS.

Upon the death of a benefit claimant who has completed a compensable period prior to his death, distribution of benefits due him will be made to the surviving spouse or, if none, to the dependent child or children. If there is no surviving spouse nor dependent child or children, the benefits become the property of the claimant's estate. (3-23-22)

226. -- 249. (RESERVED)

250. DETERMINATIONS/APPELLATE PROCESSES.

01. Rebuttal Procedure. Whenever any information is provided in response to a claim, and the information contradicts a statement made previously, all interested parties will be given an opportunity for rebuttal. Ref. Sec. 72-1368(3), Idaho Code. (3-23-22)

02. Reestablishing Eligibility After a Determination of Ineligibility. Evidence of requalifying wages includes, but is not limited to, the name of the employer, the mailing address, the dates of employment, the type of employment performed, and the claimant's gross earnings. Ref. Sec 72-1366(14), Idaho Code. (3-23-22)

251. -- 274. (RESERVED)

275. DISCHARGE.

01. Burden of Proof. The burden of proving that a claimant was discharged for employment-related misconduct rests with the employer. (3-23-22)

02. Disqualifying Misconduct. To disqualify a claimant for benefits, misconduct must be connected with the claimant's employment and involve one of the following: (3-23-22)

a. Disregard of Employer's Interest. A willful, intentional disregard of the employer's interest. (3-23-22)

b. Violation of Reasonable Rules. A deliberate violation of the employer's reasonable rules. (3-23-22)

c. Disregard of Standards of Behavior. If the alleged misconduct involves a disregard of a standard of behavior which the employer has a right to expect of his employees, there is no requirement that the claimant's conduct be willful, intentional, or deliberate. The claimant's subjective state of mind is irrelevant. The test for misconduct in "standard of behavior cases" is as follows: (3-23-22)

i. Whether the claimant's conduct fell below the standard of behavior expected by the employer; and (3-23-22)

ii. Whether the employer's expectation was objectively reasonable in the particular case. (3-23-22)

03. Inability to Perform or Ordinary Negligence. Mere inefficiency, unsatisfactory conduct, failure of good performance as the result of inability or incapacity, inadvertencies, isolated instances of ordinary negligence,

or good faith errors in judgment or discretion are not considered misconduct connected with employment. (3-23-22)

04. Non-Job Related Conduct. If the claimant was discharged for conduct involving personal, non-job related behavior, the discharge is not for misconduct connected with employment. (3-23-22)

05. When Notice of Discharge Prompts a Resignation. If a claimant has resigned after receiving a notice of discharge (or lay off due to a lack of work), but before the effective date of the discharge, both “separations” must be considered. The following three (3) elements should be present for both actions to affect the claimant’s eligibility: (3-23-22)

a. The employee was given notice by the employer of a specific separation date; (3-23-22)

b. The employee’s decision to quit before the effective date of the termination was a consequence of the pending separation; and (3-23-22)

c. The voluntary quit occurred a short time prior to the effective date of the termination. (3-23-22)

06. Indefinite Suspension. A claimant who has been suspended without pay for an indefinite period of time, who has not been given a date to return to work, is considered discharged. (3-23-22)

276. -- 324. (RESERVED)

325. EMPLOYEES OF EDUCATIONAL INSTITUTIONS.

01. Possibility of Employment. An offer of employment by an educational institution or service agency is not “bona fide” if merely a possibility of employment exists. A possibility of employment, rather than a reasonable assurance, exists when: (3-23-22)

a. The circumstances under which the claimant would be employed are not within the control of the educational institution; and (3-23-22)

b. The educational institution does not provide evidence that such an individual normally would perform services the following academic year. (3-23-22)

02. Reasonable Assurance. “Reasonable assurance” of continuing employment exists when an educational institution or service agency provides an oral or written statement to the Department indicating that the claimant has been given a bona fide offer of a specific job in the second academic period. In addition, for such “reasonable assurance” to exist, the terms and conditions of the job offered in the second period must not be substantially less favorable than the terms and conditions of the job performed in the first period. (3-23-22)

03. Reasonable Assurance Later Given. A claimant who initially was determined not to have a reasonable assurance of continuing employment, will subsequently become disqualified for benefits under Sections 72-1366(17)(a), (b), or (c), Idaho Code, when an educational institution or service agency gives the claimant such reasonable assurance. (3-23-22)

04. Retroactive Payments. A claimant seeking retroactive payments pursuant to 72-1366(17)(b), Idaho Code, must make a request for the retroactive payment with the Department no later than thirty (30) days after the beginning of the second school year or term or retroactive payment will not be made. In addition, the claimant must provide written evidence from the employer who previously provided reasonable assurance of continuing work, that the claimant was not offered an opportunity to return to work in the second of two (2) successive school years or terms. (3-23-22)

05. Under Contract, but Between School Terms. Employees of educational institutions who are hired under contract for the school term, are considered unemployed between school terms even though they may receive their salary in twelve (12) monthly payments. (3-23-22)

326. -- 349. (RESERVED)

350. EXTENDED BENEFITS.

Ref. Sec. 72-1367A, Idaho Code.

(3-23-22)

01. Evidence of Employment for Extended Benefits. Satisfactory evidence that an individual's prospects for obtaining work in his customary occupation within a reasonably short period includes: (3-23-22)

a. A letter signed by a prospective employer giving assurances of work within the next four (4) weeks; or (3-23-22)

b. A verifiable, written statement by the claimant that he will have work within the next four (4) weeks. (3-23-22)

02. Remuneration Earned. Remuneration earned must be in employment where an employee-employer relationship exists to satisfy requalification requirements for Extended Benefits. (3-23-22)

351. -- 374. (RESERVED)

375. FULLY EMPLOYED/NOT UNEMPLOYED.

Ref. Section 72-1312(1), Idaho Code.

(3-23-22)

~~**01. Excessive Earnings Week.** An excessive earnings week is a week in which the claimant's wages allocable to that week are more than one and one half (1 1/2) times the claimant's weekly benefit amount. (3-23-22)~~

021. Leave of Absence. A claimant who is on a mutually agreed upon leave of absence, and whose employer has committed to the claimant's return to work at the end of the leave, is employed and not eligible for benefits. (3-23-22)

032. Suspension. A claimant suspended with or without pay for a specific number of days, who has been given a date to resume employment after the suspension, is not considered unemployed and is not eligible for benefits. (3-23-22)

043. Corporate Officer. (3-23-22)

a. A corporate officer has the burden of proving by a preponderance of evidence that he is unemployed due to circumstances beyond his control or the control of a family member with an ownership interest in the corporation. (3-23-22)

b. Circumstances beyond a corporate officer's control or the control of a family member with an ownership interest in the corporation. Circumstances beyond a corporate officer's or a family member's control are circumstances that last through the corporate officer's benefit year end date and include, but are not limited to, the following: (3-23-22)

i. Unemployment due to the corporate officer's removal from the corporation under circumstances that satisfy the personal eligibility conditions of Section 72-1366, Idaho Code; (3-23-22)

ii. Unemployment due to dissolution of the corporation; or (3-23-22)

iii. Unemployment due to the sale of the corporation to an unrelated third party. (3-23-22)

376. -- 399. (RESERVED)

400. LABOR DISPUTE/UNION RULES.

A "labor dispute" is a controversy with respect to wages, hours, working conditions, or right of representation affecting the work or employment of a number of individuals employed for hire which results in a deadlock or impasse between the contending parties. Ref. Sec. 72-1366(7), (10), Idaho Code. (3-23-22)

01. Burden of Proving Nonparticipation. The burden of proving non-participation, lack of financing and similar factors is upon the claimant. (3-23-22)

02. Involvement of Work Site in Labor Dispute. A claimant will not be denied benefits because of a labor dispute if the dispute is not in any way directly connected with the factory, establishment, or premises at which the individual is or was last employed. (3-23-22)

03. Lack of Work. A claimant's unemployment will be deemed due to lack work and not due to a labor dispute if it is shown that because of the labor dispute the employer's business has fallen off to the extent that he can no longer utilize the services of the claimant due to the drop in business. (3-23-22)

04. Laid Off Before Labor Dispute. A claimant laid off because of lack of work from an employer where a labor dispute later occurred will not be considered unemployed due to the labor dispute. (3-23-22)

05. Period of Ineligibility. The period of ineligibility applies for the whole of any week in which any part of a claimant's unemployment is due to a labor dispute. (3-23-22)

06. Picketing Work Site. The act of picketing the work site of a labor dispute constitutes participation in the labor dispute, whether or not payment is made for such services. (3-23-22)

07. Refusal to Cross Picket Line. Voluntary refusal to cross a peaceable picket line to work constitutes participation in the labor dispute. (3-23-22)

08. Subsequent Employment. Subsequent employment does not make the claimant eligible for benefits if his unemployment is still due to the labor dispute. As long as the claimant intends to return to the employer where the labor dispute exists, his unemployment is due to the labor dispute regardless of any intervening employment. (3-23-22)

09. Termination of Labor Dispute. The period of ineligibility due to the labor dispute terminates at the end of the calendar week in which the labor dispute no longer exists. The termination of the dispute does not automatically make a claimant eligible for benefits. (3-23-22)

10. Union Member. The fact that an individual is a dues-paying union member alone does not constitute financing a labor dispute. Nor does the fact that he is not a union member establish that he is not financing or participating in the dispute. (3-23-22)

401. -- 424. (RESERVED)

425. NEW CLAIMS/ADDITIONAL CLAIMS. Ref. Sec. 72-1308, Idaho Code. (3-23-22)

01. Claims for Benefits, Delayed Filing. When the Central Claims Office has determined that a claimant's attempt to file an initial claim was delayed due to problems with the Department's telephone or electronic filing system, the claim may be backdated if the claimant reported the access problem to the Central Claims Office within seven (7) days of the date the problem occurred. When a claim is backdated, the continued claim report for the period of time involved is timely if filed during the same week or the next week after the claim is filed. (3-23-22)

02. Effective Date of Backdated Claims. When the filing of an initial claim for benefits is backdated due to a Department system malfunction, the effective date is the Sunday of the week in which the claimant first reported to the Central Claims Office to file the claim or attempted to access the telephone or electronic claim filing system and there were problems with the system. (3-23-22)

03. Filing of New Claims, Additional, and Reopen Claims. For purposes of this section, "new claim" means the first initial claim made in a benefit year. Intrastate and interstate claims, including, without limitation, new claims, additional claims, and reopen claims, may be filed electronically or by telephone at the Department's discretion. (3-23-22)()

a. Electronically Filed Claims. Claimants may file claims electronically by accessing Idaho's Internet claim system or, if filing through an American Job Center, by accessing the Department's Intranet claim system. Electronically filed claims will be date and time stamped at the time the claimant completes the application process. The claim will not be completed until the claimant has finished the process and has electronically submitted the claim to the Department. A claim filed via the Internet or an American Job Center is effective as of the Sunday of the week of the date shown on the date/time stamp. (3-23-22)

b. Interstate Claims. Any claim filed by an interstate claimant is accepted in the same manner and conditions for which claims are accepted from intrastate claimants. (3-23-22)

c. Telephone Claims. A claimant may also file a claim by calling the Central Claims Office. A claim filed via telephone is effective as of the Sunday of the week in which the claimant first calls the Central Claims Office to initiate the claim. (3-23-22)

d. Claimants' Electronic Verification. A unique ~~confidential number or other electronic method of verification~~ password or personal identification number approved by the Department may be used by a claimant or an employer to submit information or engage in transactions with the Department through electronic or telephonic means. Use of this method of verification has the same force and effect as a manual signature. (3-23-22)()

04. Registration/Reporting Requirements -- Interstate Claimants. Interstate claimants are required to comply with the same reporting requirements prescribed for regular Idaho intrastate claimants. Ref. Sec. 72-1366(1), (2), Idaho Code. (3-23-22)

05. Requirement to Provide Information. If a claimant fails to provide the Department with all necessary information pertinent to eligibility, the claimant is denied benefits until the information is provided. Any individual making a claim for benefits must provide the Department with: (3-23-22)

a. The claimant's legal name; (3-23-22)

b. The claimant's Social Security Number; (3-23-22)

c. The address where the claimant's mail is delivered; (3-23-22)

d. The claimant's place of last employment; (3-23-22)

e. The name, correct mailing address, dates of employment, and the reason for separation from all of the claimant's most recent and base-period employers; (3-23-22)

f. If requested by the Department, a list of all other employment in the past twenty-four (24) months; (3-23-22)

g. The claimant's plans for finding other employment at the earliest possible time; and (3-23-22)

h. Other information necessary for the proper processing of the claim. (3-23-22)

i. Once a claim has been established, the claimant must provide, upon request, a record of the claimant's work search, in order for the Department to assess compliance with personal eligibility requirements. (3-23-22)

j. If the claimant's identifying information does not match with data provided by the Social Security Administration, the Division of Motor Vehicles, or other public entities for identity verification purposes, the claimant will be provided notice and an opportunity to provide proof of identity before benefits are denied. (3-23-22)

06. Separation Notice. (3-23-22)

a. Notice to Employer of Separation. Every employer (including employers not subject to Title 72, Chapter 13, Idaho Code), when contacted by a Department representative for a response, must respond to the

Department with the reasons for the separation whenever the claimant: (3-23-22)

- i. Left his employment voluntarily; (3-23-22)
- ii. Was discharged from his employment due to misconduct; (3-23-22)
- iii. Is unemployed due to a strike, lockout, or other labor dispute; (3-23-22)
- iv. Is not working due to a suspension; or (3-23-22)
- v. Was separated for any other reason except lack of available work. (3-23-22)

b. Employer Response. The employer's response must be given by the employer or on the employer's behalf by someone having personal knowledge of the facts concerning the separation. The employer should provide to the Department, via electronic media or mail, copies of any documentation supporting their position. (3-23-22)

07. Additional Claim or Reopened Claim. A claim must be reestablished after a claimant has failed to report or has reported excessive earnings for two (2) or more consecutive weeks. (3-23-22)

08. Use of Wage Credits. All unemployment insurance wage credits from any source that are assignable to the state of Idaho will be used in establishing a claim and determining the claimant's monetary eligibility. Ref. Sec. 72-1367(1), Idaho Code. (3-23-22)

09. Valid Claim. To be a valid claim for benefits, a claim must be filed during a week of no work, a week of less than full-time work in which the total wages payable to the claimant for work performed in such week amount to less than one and one-half (1-1/2) times the claimant's weekly benefit amount, or a week in which the claimant is separated from employment. Ref. Sec. 72-1327A and 72-1312, Idaho Code. (3-23-22)

426. -- 449. (RESERVED)

450. QUIT. Ref. Sec. 72-1366(5), Idaho Code. (3-23-22)

01. Burden of Proof. The claimant has the burden of proof to establish that he voluntarily left his employment with good cause in connection with the employment to be eligible for benefits. (3-23-22)

02. Cause Connected with Employment. To be connected with employment, a claimant's reason(s) for leaving the employment must arise from the working conditions, job tasks, or employment agreement. If the claimant's reason(s) for leaving the employment arise from personal/non job-related matters, the reasons are not connected with the claimant's employment. (3-23-22)

03. Good Cause. The standard of what constitutes good cause is the standard of reasonableness as applied to the average man or woman. Whether good cause is present depends upon whether a reasonable person would consider the circumstances resulting in the claimant's unemployment to be real, substantial, and compelling. (3-23-22)

04. Moral or Ethical Quit. A claimant who leaves a job because of a reasonable and serious objection to the work requirements of the employer on moral or ethical grounds and is otherwise eligible, will not be denied benefits. (3-23-22)

05. Quit Due to Health or Physical Condition. A claimant whose unemployment is due to his health or physical condition which makes it impossible for him to continue to perform the duties of the job will be deemed to have quit work with good cause connected with employment. (3-23-22)

06. Quit for Permanent Work or Quit Part-Time Work for Increase in Work Hours. A claimant who quits a temporary job for a permanent job or who quits part-time employment for employment with an increase in the number of hours of work will be deemed to have quit work with good cause connected with employment.

(3-23-22)

07. Quit or Retirement During Employer Downsizing. An individual who has continuing suitable work available and who voluntarily elects to retire or to terminate employment during a period of reorganization or downsizing will be deemed to have voluntarily quit the employment for personal reasons. (3-23-22)

08. Unrelated Discharge Prior to Pending Resignation. The eligibility of a claimant discharged before a pending resignation has occurred for reasons unrelated to the pending resignation will be determined on the basis of the discharge. (3-23-22)

09. When Notice of Resignation Prompts a Discharge. If a claimant had given notice of a pending resignation, but was discharged before the effective date of the resignation, both “separations” must be considered. The following three (3) elements should be present for both actions to affect the claimant’s eligibility: (3-23-22)

a. The employee gave notice to the employer of a specific separation date; (3-23-22)

b. The employer’s decision to discharge the claimant before the effective date of the resignation was a consequence of the pending separation; and (3-23-22)

c. The discharge occurred a short time prior to the effective date of the resignation. (3-23-22)

10. Quit Due to Harassment. Good cause for quitting employment may be established by showing the party was subjected to any form of harassment that is unlawful under the Idaho Human Rights Act, Title 67, Chapter 59, Idaho Code. (3-23-22)

451. -- 459. (RESERVED)

460. PROFESSIONAL ATHLETES BETWEEN SEASONS.
Ref. Sec. 72-1366(18), Idaho Code. (3-23-22)

01. Base Period Wages. No base period wages are used to establish a claim when substantially all services performed during the base period consist of participation in sports, athletic events, training, or preparing to so participate, for any week which commences during the period between two (2) successive sport seasons (or similar periods) if the individual performed such services in the first season (or similar period) and there is a reasonable assurance that the individual will perform such services in the later of such seasons (or similar periods). (3-23-22)

02. Reasonable Assurance. Reasonable assurance requires the following: (3-23-22)

a. The claimant has a contract, either written or oral; (3-23-22)

b. The claimant offered to work and the employer expressed an interest in hiring the player for the next season (or similar period); or (3-23-22)

c. The claimant expresses a readiness and willingness or intent to participate in the sport the following season. Reasonable assurance exists if the claimant asserts he or she intends to pursue employment as a professional athlete the next season despite not having a specific employer to return to or a formal offer of employment. (3-23-22)

03. Substantially All Services. An individual is deemed to have performed “substantially all services” in sports, athletic events, training, or preparing to so participate if ninety percent (90%) or more of the base period wages were based on such services. (3-23-22)

461. -- 474. (RESERVED)

475. REFUSAL OF WORK/FAILURE TO APPLY.
Ref. Sec. 72-1366(6), (7), Idaho Code. (3-23-22)

01. Citizenship or Residency Requirements. An employer’s restrictions on citizenship or residency

is deemed good cause for a claimant's failure to apply for available work if he does not meet the requirements. (3-23-22)

02. Claimant Conduct. A claimant who, by his conduct, causes an employer to withdraw an offer of suitable work or terminate the offer after the claimant has accepted it is ineligible. (3-23-22)

03. Claimant Responsibility. A claimant has the responsibility to apply for and accept suitable work. (3-23-22)

04. Conscientious Objection. A claimant may refuse employment that requires him to work on his Sabbath if his religious convictions do not permit him to work on that day. (3-23-22)

05. Employer Requirements. Claimants are expected to comply with reasonable, lawful requirements that are typical of certain occupations, such as a requirement that a worker be bonded. Unreasonable requirements by employers will not be used as a basis to deny benefits. However, a claimant must have good cause to refuse or fail to meet an employer's reasonable, lawful employment requirements to be eligible for benefits. (3-23-22)

06. Failure to Report. A claimant who fails to report to the Department when so directed, fails to follow explicit instructions for applying for suitable, available work, or fails to report to work after accepting employment, without good cause, is ineligible. Ref. Sec. 72-1366(2), (6), Idaho Code. (3-23-22)

07. Failure to Return to Work After Layoff. A claimant who has been laid off, but fails to return to work on the date specified by the employer at the time of layoff or fails to respond to a callback after a layoff, will be considered to have refused an offer of work if the ongoing employment relationship is severed as a result. If the claimant declines work with the employer but the ongoing employment relationship is not severed as a result, the claimant's availability for work will be examined, but the claimant will not be considered to have refused an offer of work under Sections 72-1366(6) or (21)(a)(ii)(A), Idaho Code. (3-23-22)

08. Government Requirements. A claimant who cannot meet government requirements within a reasonable period of time has good cause for refusing that opportunity to work. (3-23-22)

09. Moral Objections. A claimant is not ineligible for failing to apply for or accept employment if the claimant has reasonable, serious objections to the work or the workplace on moral or ethical grounds. (3-23-22)

10. Offer of Work. A claimant whose unemployment is due to his failure without good cause to accept available, suitable work is ineligible. The job offer must have been genuine and known to the claimant. (3-23-22)

11. Part-Time Work. A claimant must be available for and willing to accept suitable part-time work in the absence of suitable full-time work. (3-23-22)

12. Personal Circumstances. To have good cause to refuse to apply for or accept available, suitable work because of personal circumstances, a claimant must show that his circumstances were so compelling that a reasonably prudent individual would have acted in the same manner under the same circumstances. (3-23-22)

13. Prospect of More Suitable Work. A claimant is not ineligible for failing to accept employment if he has excellent prospects for more suitable work with his former employer or in his regular occupation. (3-23-22)

14. Suitable Work. Every claimant has the right to restrict his availability to suitable work. (3-23-22)

15. Travel Distance. A claimant is not ineligible if the travel distance to available work is excessive or unreasonable. A claimant is ineligible if he fails to apply for and accept suitable work within a commuting area similar to other workers in his area and occupation. (3-23-22)

~~476.—499.~~ (RESERVED)

~~500. REISSUING BENEFIT PAYMENTS.~~

~~Whenever a benefit payment is lost, stolen, destroyed, or forged, the claimant will be issued a new benefit payment~~

~~upon his proper presentation of the facts and submission of an affidavit, in a form prescribed by the Department, for the issuance of a new benefit payment. Ref. Section 72-1368(1), Idaho Code. (3-23-22)~~

~~**01. Affidavit for Issuance of New Benefit Payment.** A claimant's affidavit filed for the issuance of a new benefit payment must be signed before a notary public or an authorized representative of the Department. (3-23-22)~~

~~**02. Reissuance of Stolen Benefit Payments.** If a claimant knows who took a benefit payment, he must provide evidence that he has taken all reasonably available legal steps and been unsuccessful in recovering the benefit payment before the Department will consider reissuing the benefit payment. (3-23-22)~~

~~501476.~~ -- 524. (RESERVED)

525. REPORTABLE INCOME.
Ref. Sections 72-1312, 72-1328, Idaho Code. (3-23-22)

01. Back Pay or Disputed Wages. Amounts received as a result of labor relations awards or judgments for back pay, or for disputed wages, constitute wages for the weeks in which the claimant would have earned them, or are assignable to the weeks stipulated in the award or judgment. (3-23-22)

02. Disability/Injury Compensation. Injury or disability compensation payments are not considered wages and are not reportable income for unemployment insurance purposes. (3-23-22)

~~**03. Disability Retirement Payments.** Retirement payments as a result of disability are treated the same as other types of retirement payments. Ref. Section 72-1312(4), Idaho Code. (3-23-22)~~

043. Gratuities or Tips. Gratuities or tips must be reported by a claimant for the week in which each gratuity or tip is earned. (3-23-22)

~~**054. Holiday Pay.** Holiday pay must be reported as though earned in the week in which the holiday occurs. (3-23-22)~~

065. Non-Periodic Remuneration. All non-periodic remuneration such as one-time severance pay, profit sharing, and bonus pay is reportable for the week in which paid. (3-23-22)

~~**076. Penalty or Damage Awards.** Amounts awarded to a claimant as a penalty or damages against an employer, other than for lost wages, do not constitute wages. (3-23-22)~~

087. Pension, Retirement, or Annuity Payments. The pension deduction provision of Section 72-1312(4), Idaho Code, only applies if the pension, retirement pay, annuity, or other similar periodic payment is made under a plan maintained or contributed to by a base period employer. The dollar amount of the weekly pension will be deducted from the claimant's weekly benefit amount unless the claimant has made contributions toward the pension. If the claimant has made contributions toward the pension plan, no deduction for the pension will be made from the claimant's weekly benefit amount. Ref. Section 72-1312(4), Idaho Code. (3-23-22)

a. Pension Contributions. The burden is on the claimant to establish by substantial, competent evidence that he has made contributions toward the pension, retirement pay, annuity or other similar payment plan. (3-23-22)

b. Pension Payment Changes. Any change in the amount of the pension, retirement, or annuity payments which affects the deduction from the claimant's weekly benefit amount will be applied in the first full week after the effective date of the change. (3-23-22)

~~**098. Relief Work or Public Assistance.** (3-23-22)~~

~~**a.** Remuneration received for relief work or public service work will be considered wages on the same basis as any other employment. (3-23-22)()~~

~~b. Eligibility When Public Assistance Received. A person receiving public assistance is eligible for benefits if no work is involved and the claimant is otherwise eligible. (3-23-22)~~

~~109.~~ **Severance Pay.** An equal portion of a periodic severance payment must be reported in each week of the period covered by the payment. However, severance pay received in a lump sum payment at the time of severance of the employment relationship must be reported when paid. (3-23-22)

~~140.~~ **Vacation Pay.** Vacation pay allocable to a certain period of time in accordance with an employment agreement must be reported in the week to which it is allocable. However, vacation pay received in a lump-sum payment at the time of severance of the employment relationship must be reported when paid. (3-23-22)

~~12. Verification of Earnings on Claim Reports. The Department may verify the earnings and/or reasons for separation reported by claimants on claim reports filed for benefit payments. Ref. Section 72-1368(1), Idaho Code. (3-23-22)~~

~~131.~~ **Wages for Contract Services.** A person who is bound by a contract which does not prevent him from accepting other employment but who receives pay for a period of not working, is required to report the contract payments as earnings in equal portions in each week of the period covered by the contract. This rule does not apply to employees of educational institutions. (3-23-22)

~~142.~~ **Wages for Services Performed Prior to Separation.** Wages for services performed prior to a claimant's separation are reportable for the week in which earned. (3-23-22)

~~153.~~ **Temporary Disability Benefits.** For any week with respect to which a claimant is receiving or has received temporary disability benefits under a worker's compensation law of any state or under a similar law of the United States, such payments must be reported in an amount attributable to such week. (3-23-22)

526. -- 549. (RESERVED)

550. REPORTING REQUIREMENTS.

Each claimant must report weekly or biweekly for benefits as directed. When filing claim reports, a claimant must use the reporting method assigned by the Department. Failure to file timely reports in a manner required by this rule will result in ineligibility for benefits for the week(s) claimed. Ref. Section 72-1366(1), Idaho Code. (3-23-22)

01. Mailed Reports. Reports that are mailed are considered timely when the envelope containing the report is postmarked within nine (9) calendar days immediately following the week(s) being claimed, except if the ninth day is a holiday, the report period will extend to the next working day. (3-23-22)

02. Internet Reports. Reports filed via the Internet are considered timely when made between 12:00 a.m., mountain time zone, of the Sunday following the week being claimed and midnight 11:59 p.m., mountain time zone of the Saturday following the week being claimed. (3-23-22)

03. Facsimile Reports. Reports filed by facsimile are considered timely when transmitted on a form provided by the Department to a telephone number designated by the Department to receive such documents within nine (9) calendar days immediately following the week(s) being claimed, except if the ninth day is a holiday, the reporting period will extend to the next working day. Reports are deemed filed upon receipt by the Department. (3-23-22)

04. Electronic Mail Reports. Reports filed by electronic mail are considered timely when electronically mailed in a format provided by the Department to an email address designated by the Department to receive such documents within nine (9) calendar days immediately following the week(s) being claimed, except if the ninth day is a holiday, the reporting period will extend to the next working day. Reports are deemed filed upon receipt by the Department. (3-23-22)

05. Telephone Reports. Reports filed by telephone are timely if the claimant contacts the Central Claims Office at a telephone number designated by the Department to provide such reports during regular business

hours within nine (9) calendar days immediately following the week(s) being claimed, except if the ninth day is a holiday, the report period will extend to the next working day. (3-23-22)

06. When Report Missing. If a claimant establishes, by credible and corroborated evidence, that a missing report was properly filed as required by this rule, a replacement report will be considered timely. (3-23-22)

551. -- 574. (RESERVED)

575. SEEKING WORK.
Ref. Sec. 72-1366(4), (6), Idaho Code. (3-23-22)

~~**01. Attitude and Behavior.** A claimant's attitude and behavior must be conducive to a positive reaction by employers to his job search. (3-23-22)~~

~~**02. Effort to Secure Employment.** A claimant will be expected to do what is normally done by unemployed persons that are seeking work. (3-23-22)~~

~~**03. Employer's Hiring Practices.** An employer's reluctance to hire a claimant because of his appearance or physical condition is not a determining factor in ruling on the claimant's eligibility. (3-23-22)~~

041. Job Attachment Classifications. For the purpose of administering the work search requirements of Section 72-1366(4) and (6), Idaho Code, a claimant will be classified according to his attachment to an employer or industry, as follows: (3-23-22)

a. Code ~~R-Recall, U-Union~~ or ~~X-Both~~ **Attached.** A claimant who has a firm attachment to an employer, industry or union, or who is temporarily or seasonally unemployed, and expects to return to his former job or employer in a reasonable length of time not to exceed a maximum of sixteen (16) weeks. If during the sixteen (16) weeks the claimant returns to work temporarily for the job attached employer, the claimant's period of job attachment will be extended by one (1) week for each week of verified full-time employment as defined by Section 72-1312, Idaho Code. (3-23-22)()

b. Code ~~B~~ **Workseeking.** A claimant who possesses marketable skills in an occupation, but has no immediate prospects for reemployment, and whose employment expectations (i.e., wages, hours, etc.) are realistic in relation to the normal labor market supply and demand in his area of availability. (3-23-22)()

c. Code ~~D~~ **Approved Training.** A claimant who is assigned to a training course under the provisions of Section 72-1366(8), Idaho Code. (3-23-22)()

~~**05. Jobs Availability.** A claimant will not be required to make useless employer contacts if there are no jobs available in the area due to seasonal factors. (3-23-22)~~

062. License or Permits. A claimant must provide or be capable of obtaining a license or permit if required by law for performance of the work. (3-23-22)

073. No Employment Prospects. A claimant must apply for and accept a lower or beginning pay rate for employment if he has no prospects for a better paying job in the locality. (3-23-22)

084. Seasonal Availability. A claimant who is regularly employed on a seasonal basis must be available for other types of work in the off-season to be eligible for benefits. (3-23-22)

095. Work-Seeking Requirement Categories. A claimant must seek work in accordance with the following categories of work-seeking activity, as instructed by a Department representative or as notified by the Department via electronic claims messaging. A claimant must meet the requirements of the code to which the claimant is assigned. A claimant's category of work-seeking activity will be determined and modified based on the claimant's prevailing local labor market conditions and/or the average county unemployment rates. Failure to comply with work-seeking requirements will result in a denial of benefits. (3-23-22)

- a. Code ~~0~~ zero (0) claimant must maintain regular contact with his employer(s) or union. (3-23-22)()
- b. ~~Code 1 claimant must engage in one (1) or more of the following activities to increase his prospects of securing employment:~~ Code five (5) claimant must make work search actions in accordance with 72-1366(4)(a)(i). (3-23-22)()
- Office; i. ~~Make at least one (1) employer contact each week in the manner prescribed by the Central Claims~~ (3-23-22)
- ii. ~~Attend a Job Search Workshop;~~ (3-23-22)
- iii. ~~Expand work search efforts to surrounding areas or states;~~ (3-23-22)
- iv. ~~Send resumes to firms/businesses that hire people with his skills;~~ (3-23-22)
- v. ~~Enroll in and attend a specific training program to meet the requirements of the claimant's employment plan; or~~ (3-23-22)
- vi. ~~Engage in other work search activities such as resume preparation or labor market research, as prescribed by a Department representative.~~ (3-23-22)
- e. ~~Code 2 claimant must engage in one (1) or more of the following activities to increase his prospects of securing employment:~~ (3-23-22)
- Office; i. ~~Make at least two (2) employer contacts per week in the manner prescribed by the Central Claims~~ (3-23-22)
- ii. ~~Attend a Job Search Workshop;~~ (3-23-22)
- iii. ~~Expand work search efforts to surrounding areas or states;~~ (3-23-22)
- iv. ~~Send resumes to firms/businesses that hire people with their skills;~~ (3-23-22)
- v. ~~Enroll in and attend a specific training program to meet the requirements of the claimant's employment plan; or~~ (3-23-22)
- vi. ~~Engage in other work search activities such as resume preparation or labor market research, as prescribed by a Department representative.~~ (3-23-22)
- d. ~~Code 3 claimant must engage in one (1) or more of the following activities to increase his prospects of securing employment:~~ (3-23-22)
- Office; i. ~~Make at least three (3) employer contacts per week in the manner prescribed by the Central Claims~~ (3-23-22)
- ii. ~~Attend a Job Search Workshop;~~ (3-23-22)
- iii. ~~Expand work search efforts to surrounding areas or states;~~ (3-23-22)
- iv. ~~Send resumes to firms/businesses that hire people with their skills;~~ (3-23-22)
- v. ~~Enroll in and attend a specific training program to meet the requirements of the claimant's employment plan; or~~ (3-23-22)
- vi. ~~Engage in other work search activities such as resume preparation or labor market research, as prescribed by a Department representative.~~ (3-23-22)

576. -- 599. (RESERVED)

600. SELF-EMPLOYMENT.

A claimant is ineligible when his self-employment is of such size and nature that the operation of it is his principal duty and working for an employer is merely incidental. Ref. Sec. 72-1366(13), Idaho Code. (3-23-22)

01. Occupational Conflicts. Agricultural activities, commercial enterprises, family enterprises, and commission sales work are examples of self-employment which may render a claimant ineligible unless he can show he is seeking employment and is available for suitable work. (3-23-22)

02. Potential Employability. A claimant is eligible if his self-employment in no way interferes with his potential employability and work schedule. (3-23-22)

~~601. -- 649. (RESERVED)~~

~~650. SIGNATURES OF ILLITERATES AND WITNESSES.~~

~~If a claimant is unable to write his name, he must instead use the mark (X). The mark must be witnessed by a Department representative or an individual who must enter, immediately after the mark (X), the words "His Mark." Next, the name of the claimant must be printed, followed by the signature of the Department representative or the individual who witnessed the mark. Ref. Sec. 72-1366(1), Idaho Code. (3-23-22)~~

~~651~~**01. -- 674. (RESERVED)**

675. TOTAL TEMPORARY DISABILITY ALTERNATE BASE PERIOD (TTD).

The alternate base period provision of Section 72-1306(2), Idaho Code, will apply only if the claimant cannot establish monetary eligibility by using the regular base period described in of Section 72-1306(1), Idaho Code. (3-23-22)

676. -- 699. (RESERVED)

700. PARTIAL PAYMENTS OF AMOUNTS OWED THE DEPARTMENT.

Upon the Department's receipt of a partial payment of an overpayment and accrued interest and penalties thereon, the Department must, unless other arrangements have been made with the debtor and approved by the Department, apply the partial payment to the amounts owed as follows: (3-23-22)

01. Interest. The partial payment must be applied first to any accrued interest of the amounts due, starting with the oldest accrued interest; (3-23-22)

02. Penalties. After any accrued interest has been paid in full, the partial payment must be applied next to any assessed penalties, starting with the oldest assessed penalty; (3-23-22)

03. Fraud Overpayments. After all accrued interest and assessed penalties have been paid in full, the partial payment must be applied next to any fraud overpayments due, starting with the oldest fraud overpayment; and (3-23-22)

04. Nonfraud Overpayments. After all fraud overpayments have been paid in full, the partial payment must be applied next to any nonfraud overpayments, starting with the oldest nonfraud overpayment. Ref. Sec. 72-1369, Idaho Code. (3-23-22)

701. -- 724. (RESERVED)

725. RECOVERIES.

Unless the overpayment resulted from a determination that the claimant willfully made a false statement or willfully failed to report a material fact, overpayments will be deducted from any future benefits payable. Ref. Secs. 72-1369 and 72-1366, Idaho Code. (3-23-22)

726. – 749. (RESERVED)

750. WAIVER OF REPAYMENT.

An interested party must submit a written request for a waiver of repayment within fourteen (14) days of the date of mailing of the Determination of Overpayment. Ref. Sec.72-1369 (3-23-22)

751. – 999. (RESERVED)

IDAPA 09 – IDAHO DEPARTMENT OF LABOR
09.01.35 – UNEMPLOYMENT INSURANCE TAX ADMINISTRATION RULES
DOCKET NO. 09-0135-2401 (ZBR CHAPTER REWRITE)
NOTICE OF RULEMAKING – PROPOSED RULE

AUTHORITY: In compliance with Section 67-5221(1), Idaho Code, notice is hereby given that this agency has initiated proposed rulemaking procedures. The action is authorized pursuant to Sections 72-1300 et seq., Idaho Code, Sections 45-600 et seq., 74-106(7), Idaho Code.

PUBLIC HEARING SCHEDULE: Public hearing(s) concerning this rulemaking will be scheduled if requested in writing by twenty-five (25) persons, a political subdivision, or an agency, not later than Oct. 16, 2024.

The hearing site(s) will be accessible to persons with disabilities. Requests for accommodation must be made not later than five (5) days prior to the hearing, to the agency address below.

DESCRIPTIVE SUMMARY: These rules are being presented for authorization as part of the IDOL’s plan to review each rule every 5 years. There are no specific rulemaking changes planned by the IDOL at this time except for evaluation and amendment consistent with the Governor’s [Zero-Based Regulation Executive Order](#). It is anticipated that rulemaking stakeholders will propose and advocate for rulemaking changes as part of the negotiated rulemaking process. The IDOL intends to carefully consider all changes presented by the public and may propose certain changes so long as they are consistent with the rules’ statutory authority and the Governor’s Executive Order. The IDOL will review the documents that are currently incorporated by reference in this rule and update that list as applicable.

FEE SUMMARY: The following is a specific description of the fee or charge imposed or increased: N/A.

FISCAL IMPACT: The following is a specific description, if applicable, of any negative fiscal impact on the state General Fund greater than ten thousand dollars (\$10,000) during the fiscal year resulting from this rulemaking: No fiscal impact.

NEGOTIATED RULEMAKING: Pursuant to Section 67-5220(1), Idaho Code, negotiated rulemaking was conducted. The Notice of Intent to Promulgate Rules - Negotiated Rulemaking was published in the July 3, 2024, Idaho Administrative Bulletin, [Vol. 24-7, page 61-62](#).

INCORPORATION BY REFERENCE: Pursuant to Section 67-5229(2)(a), Idaho Code, the following is a brief synopsis of why the materials cited are being incorporated by reference into this rule: N/A.

ASSISTANCE ON TECHNICAL QUESTIONS, SUBMISSION OF WRITTEN COMMENTS: For assistance on technical questions concerning the proposed rule, contact Darlene Carnopis at 208-696-2380.

Anyone may submit written comments regarding this proposed rulemaking. All written comments must be directed to the undersigned and must be delivered on or before Oct. 23, 2024.

DATED this 30th day of August, 2024.

Darlene Carnopis
Policy Coordinator
Idaho Department of Labor
317 W. 3rd St.
Boise, ID 83702
Phone: (208) 696-2380
Email: darlene.carnopis@labor.idaho.gov

THE FOLLOWING IS THE PROPOSED TEXT OF DOCKET NO. 09-0135-2401
(ZBR Chapter Rewrite)

09.01.35 – UNEMPLOYMENT INSURANCE TAX ADMINISTRATION RULES

000. LEGAL AUTHORITY.

These rules are promulgated under Section 72-1333, Idaho Code. (3-23-22)

001. SCOPE.

These rules govern Department procedures and the rights and duties of employers under the Unemployment Insurance Program. (3-23-22)

002. ADMINISTRATIVE APPEALS.

Administrative appeals from determinations under this chapter may be taken as provided in IDAPA 09.01.01, “Rules of Administrative Procedure of the Department of Labor,” and Sections 72-1361 and 72-1368, Idaho Code. (3-23-22)

003. -- 010. (RESERVED)

011. GENERAL PROVISIONS.

01. Quarterly Reporting. Subject employers shall report all wages paid for services in covered employment each calendar quarter. In the event a subject employer does not pay wages during a calendar quarter, the employer shall file a quarterly report indicating that no wages were paid. Ref. Section 72-1337, Idaho Code. (3-23-22)

02. Contribution Due Date. If the normal due date falls on a weekend or holiday the next workday is the due date for contributions. Ref. Section 72-1349, Idaho Code. (3-23-22)

03. Penalties and Interest on Bankruptcy. Penalty and/or interest shall not be assessed on amounts covered in the Department’s Proof of Claim with the Bankruptcy Court for the period after the filing date of the Bankruptcy Petition and ending with the conclusion of bankruptcy proceedings and distribution of assets. Post petition penalty and interest shall be compromised, provided the amount due is paid in full by a date established after the termination of the bankruptcy proceedings. Ref. Section 72-1356, Idaho Code. (3-23-22)

04. Lien Interest. Lien interest on a delinquent account shall be assessed against the remaining unpaid balance computed from the day following the recording of a tax lien. Ref. Section 72-1360, Idaho Code. (3-23-22)

~~**05. Penalty and Interest During Controversy.** Penalty and/or interest shall be compromised for periods when a valid controversy exists if amounts determined to be due are paid in full by a date established at the conclusion of the issue. Ref. Sections 72-1354 and 72-1360, Idaho Code. (3-23-22)~~

~~**06.5. Determinations and Appeals.** The rules governing the form, filing, and other procedures relating to determinations under this chapter, and any appeal from those determinations, are provided in IDAPA 09.01.01, “Rules of Administrative Procedure of the Department of Labor.” (3-23-22)~~

~~**07. When Reports Replace Determinations.** In cases where a determination of amounts due is made by the Department pursuant to Section 72-1358, Idaho Code, the reports shall replace the determination and will be used to establish the employer’s liability if: (3-23-22)~~

~~**a.** The employer files reports for the periods covered by the determination before the determination becomes final; and (3-23-22)~~

~~**b.** The Department determines that the reports are accurate and complete. If the Department~~

~~determines the reports are not accurate or complete, the reports shall be treated as an appeal of the determination.~~
(3-23-22)

086. Determination of Payment Date. Each amount shall be deemed to have been paid on the date that the Department receives payment thereof in cash or by check or other order for the payment of money honored by the drawer on presentment; provided, that if sent through the mail, it shall be deemed to have been paid as of the date mailed as determined by the postmark on the envelope containing same, or the date of the check in lieu of a postmark. Provided further, that in the case of payments received by means of garnishment, execution, or levy, the amount received shall be deemed to have been paid as of the date that the order of garnishment, execution, or levy is served. Ref. Section 72-1349, Idaho Code. (3-23-22)

097. Release of Lien upon Payment in Full. An amount secured by a lien shall be deemed to be satisfied when payment in full is received by the Department in the form of cash, money order, or other certified funds, or proof presented that a check or other negotiable instrument has been honored by its drawer upon presentment. Ref. Section 45-1908, Idaho Code. (3-23-22)

~~108.~~ **Contribution Reports.** Each contribution shall be accompanied by an employer's contribution report. All contribution reports shall be filed electronically with the department unless the employer has petitioned the department in writing for a waiver and the department has granted a waiver allowing the filing of a non-electronic contribution report. All contribution reports shall be in a form or medium prescribed and furnished or approved for such purpose by the department, giving such information as may be required, including number of individuals employed and wages paid or payable to each, which must be signed, furnished, or acknowledged by the covered employer or, on their behalf by someone having personal knowledge of the facts therein stated, and who has been authorized by the covered employer to submit the information. Ref. Section 72-1349, Idaho Code. (3-23-22)

a. Common paymaster arrangements as referenced by Internal Revenue Code Section 3306 are prohibited for Idaho unemployment insurance purposes. Each covered employer shall complete and submit an Idaho business registration form and the Department will assign to the covered employer a unique unemployment insurance account number. The covered employer must file quarterly reports under its assigned unemployment insurance account number. The workers of one (1) covered employer may not be reported using the assigned unemployment insurance account number of a different covered employer or related entity. Ref. Sections 72-1325 and 72-1315, Idaho Code. (3-23-22)

012. -- 039. (RESERVED)

040. COMPROMISE OF PENALTY AND CIVIL PENALTY.

Pursuant to Section 72-1354, Idaho Code, the Director or his authorized representative may, for good cause shown, compromise the amount of penalties owed on an employer account. An employer shall submit a request in writing for compromise of penalties, setting forth the reason(s) for the delinquency, and attaching any available evidence supporting the request. (3-23-22)

01. Good Cause. An employer has established good cause if the employer can show that one (1) of the following criteria has been met: (3-23-22)

a. The reason for the delinquency was beyond the reasonable control of the employer. Examples of circumstances that are beyond the reasonable control of the employer include, but are not limited to, the following: (3-23-22)

i. Departmental error, including but not limited to providing incorrect information to the employer or not furnishing proper forms in sufficient time to permit timely payment of contributions; (3-23-22)

ii. Death or serious illness or injury of the employer or the employer's accountant or members of their immediate families; (3-23-22)

iii. Destruction by fire or other casualty of the employer's place of business or business records; or (3-23-22)

- iv. Postal service delays. (3-23-22)
- b. The delinquency was due to circumstances for which the imposition of penalties would be inequitable. (3-23-22)
- c. Good cause is also established in the case of an employer who has never received a status determination, who has never paid any contributions to the director, who voluntarily approaches the Department to inquire as to whether workers are engaged in covered employment, and the failure to pay contributions was due to the employer's good faith belief that the employer was not a covered employer pursuant to the provisions of Idaho Employment Security Law. Ref. Section 72-1354, Idaho Code. (3-23-22)

041. -- 050. (RESERVED)

051. ROUNDING WAGES REPORTED ON CONTRIBUTION REPORT TO NEXT LOWER DOLLAR AMOUNT.

The total wages and taxable wages shown on the contribution report which are to be used in computing contributions due shall be reduced to the next lower dollar amount. Ref. Section 72-1349, Idaho Code. (3-23-22)

052. -- 055. (RESERVED)

056. APPLICATION OF PAYMENTS ON DELINQUENT ACCOUNTS.

Unless otherwise specified and approved by the Department, apply payment as follows: (3-23-22)

01. First Application. First, credit such payment in satisfaction of interest due for the calendar quarter or period most delinquent in point of time; (3-23-22)

02. Second Application. Next, credit the remainder of such payment in satisfaction of penalty due for such calendar quarter or period most delinquent in point of time; (3-23-22)

03. Third Application. Next, credit the remainder of such payment in satisfaction of contributions due for the calendar quarter or period most delinquent in point of time; (3-23-22)

04. Subsequent Applications. Such applications shall be applied in a like manner for each remaining delinquent quarter. Any remaining credit shall be applied to interest on civil penalties then to civil penalty due until the amount of payment is exhausted. Ref. Section 72-1354, Idaho Code. (3-23-22)

057. -- 060. (RESERVED)

061. DEFINITIONS.

The definitions listed in IDAPA 09.01.35, "Unemployment Insurance Tax Administration Rules," Section 011, and the following are applicable to the UI Compliance Bureau. (3-23-22)

01. Tolerance Amount. A tolerance of four dollars and ninety-nine cents (\$4.99) is established in connection with collection of amounts due; and under normal circumstances, no delinquency or credit will be issued or carried on the books of accounts for this amount or less. Ref. Section 72-1349, Idaho Code. (3-23-22)

02. Wages. The term "wages" includes all remuneration from whatever source, paid or given in exchange for services performed or to be performed, including the cash value of remuneration in any medium other than cash. "Wages" in covered employment, and subject to unemployment insurance reporting, include, but are not limited to: (3-23-22)

a. Commissions, bonuses, draws, distributions, dividends and any other forms or types of payments made by corporations or other similar entities if paid in exchange for services; (3-23-22)

b. Bonuses, prizes, and gifts given to an employee in recognition of services, sales, or production; (3-23-22)

- c. Commissions for past services in covered employment; (3-23-22)
 - d. Remuneration paid to corporate officers which is paid in exchange for services performed or to be performed for or on behalf of the corporation; (3-23-22)
 - e. Salary advances against commissions; (3-23-22)
 - f. All forms of profit sharing for services rendered unless specifically exempt under Section 72-1328, Idaho Code; (3-23-22)
 - g. Excess travel or employer business allowances over actual expense, or over the federal allowance per diem rate for the area of travel, unless returned to the employer; (3-23-22)
 - h. Vacation or “idle-time” pay, no matter when paid; (3-23-22)
 - i. Personal expense reimbursement, not gifts, i.e., clothing, family expenses, rent. (3-23-22)
 - j. The director or his authorized representative shall determine the fair market value of any other remuneration, regardless of its classification, form, or label, which is paid to a worker in exchange for services. In making such determination, consideration will be given to the prevailing wage for similar services. Ref. Section 72-1328, Idaho Code. (3-23-22)
- 03. Exclusions From Wages.** The term “wages” described in Section 72-1328, Idaho Code, does not include the following: (3-23-22)
- a. Prizes or gifts for special occasions which are expressions of good will; (3-23-22)
 - b. Bonuses paid for signing a contract; (3-23-22)
 - c. Fees paid to participate periodically in meetings of boards of directors unless exceedingly high; i.e., amounts comparable to other employers in the same industry, of relatively the same size; (3-23-22)
 - d. Drawings or advances by partners of a partnership, or by members of a limited liability company treated for federal tax purposes as a partnership or sole proprietorship; (3-23-22)
 - e. Rental charge for personal equipment provided by the employee on the job: if (3-23-22)
 - i. There is a rental agreement; and (3-23-22)
 - ii. The worker has received a reasonable wage for services performed; and (3-23-22)
 - iii. The fees are held separately on the employer’s records. (3-23-22)
 - f. Stock or membership interests issued for purposes other than services performed or to be performed; (3-23-22)
 - g. Reimbursement for actual employee expense, or business allowance arrangements with employees that requires them: (3-23-22)
 - i. To have paid or incurred reasonable job related expenses while performing services as employees; and (3-23-22)
 - ii. To account adequately to the employer for these expenses; and (3-23-22)
 - iii. To return any excess reimbursement or allowance. (3-23-22)
 - h. Payments for employee travel expenses, provided: (3-23-22)

- i. Payments are job related expenses while performing services; and (3-23-22)
- ii. Payments do not exceed actual expenses or the federal allowance per diem rate for the area of travel; and (3-23-22)
- iii. Records for days of travel pertaining to per diem payments are verifiable. (3-23-22)
- i. Employee fringe benefits as set forth in Section 132 of the Internal Revenue Code, which are excluded from an employee's gross income and which are not subject to federal unemployment taxes. (3-23-22)
- j. Noncash payment to farmworkers. Noncash payments for farm work will be excluded from wages if they are "de minimis" in relation to the amount of cash wages paid to the farmworkers, or are not intended to be treated as the cash equivalent of wages, or as the cash payment of wages. Ref. Section 72-1328, Idaho Code. (3-23-22)
- k. Payments of any kind by a partnership to its partner or by a sole proprietorship to its owner. (3-23-22)

04. Treatment of Limited Liability Companies. For purposes of state unemployment tax coverage, a limited liability company will have the same status as it may have elected for federal tax purposes, or as that status may be determined or required by the federal government, subject to the provisions of Subsections 061.02 and 061.03. Any member of a limited liability company that has elected to be treated as a corporation for federal tax purposes shall be treated as a corporate officer for state Employment Security Law purposes. (3-23-22)

05. Domestic Employment. Domestic employment is defined as work performed in the operation or maintenance of a private home, local college club, or local chapter of a college fraternity or sorority, as distinguished from services as an employee in pursuit of an employer's trade, occupation, profession, enterprise, or vocation. In general, domestic employment "in the operation or maintenance of a private home, local college club, or local chapter of a college fraternity or sorority" includes, but is not limited to, services rendered by cooks, waiters, butlers, maids, janitors, handymen, gardeners, housekeepers, housemothers, and in-home caregivers. Ref. Section 72-1315, Idaho Code. (3-23-22)

06. Casual Labor. Casual labor is labor that meets the requirements of Section 72-1316A(19), Idaho Code. The term, "services not in the course of the employer's trade or business," refers to services that do not promote or advance the trade or business of the employer. (3-23-22)

07. Willfully. When applied to the intent with which an act is done or omitted, willfully implies simply a purpose or willingness to commit the act or make the omission referred to. It does not require any intent to violate law, in the sense of having an evil or corrupt motive or intent. It is more nearly synonymous with "intentionally," "designedly," "without lawful excuse," and therefore not accidental. Ref. Section 72-1372 and 72-1351A, Idaho Code. (3-23-22)

062. SUBSTANCE VS. FORM.

In recognizing covered employers, covered employment and in classifying wages, the Department shall examine both the substance and the form of the arrangement, contract, transaction or event, but more consideration shall be given to the substance of the arrangement, contract, transaction or event than to the form. If it is determined that true economic substance is lacking or the operations, accounting practices and records do not reflect the purported form or legal status, the Department shall, regardless of the form, determine proper coverage or classification. (3-23-22)

063. -- 080. (RESERVED)

081. EMPLOYER RECORDS.

Each person hiring one (1) or more individuals, whether or not such employment is sufficient to create the status of a covered employer, shall maintain records for five (5) years to show the information hereinafter indicated. Ref. Section 72- 1337, Idaho Code. (3-23-22)

01. Required Information. Such records shall show with respect to each employee unless the Department has ruled that the services do not constitute covered employment: (3-23-22)

- a. Full name and home address of worker; (3-23-22)
- b. Social Security account number; (3-23-22)
- c. The place of work within this State; (3-23-22)
- d. Date on which employee was hired, rehired, or returned to work after temporary or partial layoff; (3-23-22)
- e. Date employment was terminated; whether the termination occurred by voluntary action of the individual and the reason given, or by discharge or death, and the reason for discharge; (3-23-22)
- f. Wages paid for employment in each pay period and total wages for all pay periods ending in each quarter of the year, showing separately: money wages; the cash value of other remuneration; and the amount of all bonuses or commissions. (3-23-22)

02. Travel or Employee Business Expenses. Amounts paid to employees as allowances or reimbursement for travel and employee business expenses and the amounts of such expenditures actually incurred and accounted for by them. (3-23-22)

03. Records to Be Made Available. The records to be made available to the director or his authorized representative, in accordance with the provisions of Section 72-1337, Idaho Code, shall include all of the business records, such as journals, ledgers, time books, minute books, or any other records or information which would tend to establish the existence of and/or amounts paid for services performed, whether or not in covered employment, and for information necessary to assist in or enable collection efforts or any other investigations conducted by the Department. (3-23-22)

082. -- 095. (RESERVED)

096. EMPLOYER STATUS REPORT.

01. Status Report. Each employer shall report on such form or any online system as may be prescribed and furnished, such information as may be necessary to make an initial or subsequent determination of status under the Idaho Code. Said reports shall be signed by the employer, or on behalf of the employer by a duly authorized representative for such purpose. Ref. Section 72-1337, Idaho Code. (3-23-22)

02. Exceptions. The provisions of this Rule do not apply to any employer for whom the services performed do not, by virtue of the provisions of Section 72-1316, Idaho Code, constitute covered employment, except that the director reserves the right, in his discretion, to require any such employer at any time to make the reports mentioned in Section 096 of this rule. Ref. Section 72-1337, Idaho Code. (3-23-22)

097. -- 105. (RESERVED)

106. CLAIMS OF EXEMPTION.

Any employer claiming that services performed for the employer or remuneration paid by the employer does not constitute covered employment or covered wages, as defined in Section 72-1316 and 72-1328, Idaho Code, shall make a report to the Department of Labor of all pertinent facts upon which said claim is based, which report needs to be signed by the person making the claim, if he is the employer, or on behalf of the employer by an authorized representative. Ref. Section 72-1337, Idaho Code. (3-23-22)

107. REMUNERATION PAID CONSTITUTES BOTH TAXABLE WAGES AND EXCLUDED AMOUNTS.

When remuneration paid includes payment for other than wages for services performed in covered employment, the employer's records must account for wages and other remuneration separately. When this distribution is not shown on

the records, the employee's entire remuneration will be deemed to be wages. Ref. Section 72-1337, Idaho Code. (3-23-22)

108. ELECTION TO EXEMPT CORPORATE OFFICERS.

A corporation may elect to exempt one (1) or more corporate officers from coverage by registering with the Department each qualifying corporate officer it elects to exempt pursuant to Section 72-1352A, Idaho Code. Registrations in the format prescribed by the Department made on or before December 15th shall become effective on the first day of the next calendar year and remain effective for at least two (2) consecutive calendar years. Exemptions are not retroactive and no refund or credit shall be given for contributions paid before the effective date of the exemption. Exemptions continue to remain in effect after two (2) consecutive calendar years unless the exemption is terminated according to Subsection 108.04 of this rule or coverage is reinstated according to Subsection 108.05 of this rule. (3-23-22)

01. Public Company Election. A public company, as defined in Section 72-1352A, Idaho Code, may elect to exempt any bona-fide corporate officer who: (3-23-22)

a. Is voluntarily elected or voluntarily appointed in accordance with the articles of incorporation or bylaws of the corporation; (3-23-22)

b. Is a shareholder of the corporation; (3-23-22)

c. Exercises control in the daily management of the corporation; and (3-23-22)

d. Does not perform manual labor as a primary work responsibility. (3-23-22)

02. Election for Corporations That Are Not Public Companies. A corporation that is not a public company as defined in Section 72-1352A, Idaho Code, may exempt from coverage any bona-fide corporate officer who: (3-23-22)

a. Is a shareholder of the corporation; (3-23-22)

b. Voluntarily agrees to be exempted from coverage; and (3-23-22)

c. Exercises substantial control in the daily management of the corporation. (3-23-22)

03. Election to Exempt Not Applicable. The election to exempt does not apply to corporate officers covered by Sections 72-1316A, 72-1322D and 72-1349C, Idaho Code. (3-23-22)

04. Termination of Exemption. A corporate officer's exemption terminates upon the corporate officer's failure to satisfy the election criteria of Section 72-1352A, Idaho Code. It is the responsibility of the corporation to notify the Department in writing in a format required by the Department when an exempt corporate officer no longer meets the election criteria. A corporation is responsible for any taxes, penalties, and interest due after the date the exemption is terminated or should have been terminated. (3-23-22)

05. Reinstatement of Coverage. A corporation may elect to reinstate coverage for one (1) or more corporate officers previously exempted. Reinstatement requires written notice from the corporation to the Department in a format required by the Department. Reinstatement requests received by the Department on or before December 15th become effective the first day of the calendar year following the end of the exemption's initial two (2) year effective date. Coverage shall not be reinstated retroactively. (3-23-22)

06. Definitions. For purposes of this chapter: (3-23-22)

a. "Bona-fide corporate officer" is defined as any individual empowered in good faith by stockholders or directors, in accordance with the corporation's articles of incorporation or bylaws, to discharge the duties of a corporate officer. (3-23-22)

b. "Exercise substantial control in the daily management of the corporation" is defined as when an

individual makes managerial decisions over a business function or functions that have some effect on the entire corporation. This includes the authority to hire and fire, to direct other's activities in the corporation, or the responsibility to account for and pay over taxes or debts incurred by the corporation. (3-23-22)

07. Services in Employment. Unless specifically exempted, services performed by corporate officers are considered services in employment and are covered for purposes of unemployment insurance. (3-23-22)

109. -- 110. (RESERVED)

111. SERVICES PERFORMED PART IN COVERED EMPLOYMENT AND PART IN EXCLUDED EMPLOYMENT.

When wages paid cover services performed both in covered employment and excluded employment, the employer's records must show the hours and wages for covered employment and also hours and wages for excluded employment. When this distribution is not shown on the records, the employee's entire wage will be deemed to have been earned in covered employment. Ref. Section 72-1337, Idaho Code. (3-23-22)

112. DETERMINING STATUS OF WORKER.

01. Determining if Worker Is an Employee. In making a determination as to whether a worker is performing services in covered employment, it shall be determined whether the worker is an employee. To determine whether a worker is an employee, the following factors may be considered: (3-23-22)

a. The way in which the business entity represented its relationship with the worker prior to the investigation or litigation, including representations to the Internal Revenue Service; (3-23-22)

b. Statements made to the Department; (3-23-22)

c. Method of payment to the worker, in particular whether federal, state, and FICA taxes are withheld from paychecks; and (3-23-22)

d. Whether life, health, or other benefits are provided to the worker at the business entity's expense. (3-23-22)

02. Determining if Worker Is an Independent Contractor. If it cannot be determined that a worker is an employee pursuant to Subsection 112.01 above, then a determination shall be made whether the worker is an "independent contractor" pursuant to the terms of Section 72-1316(4), Idaho Code. For the purposes of that section and these rules, an independent contractor is a worker who meets the requirements of both Sections 72-1316(4)(a) and (b), Idaho Code. (3-23-22)

03. Proving Worker Is Free from Control or Direction in His Work. To meet the requirement of Section 72-1316(4)(a), Idaho Code, the alleged employer must prove that a worker has been and will continue to be free from control or direction in the performance of his work, both under his contract of service and in fact. The following factors may be considered in this determination: (3-23-22)

a. Whether the alleged employer has control over the details of the work, the manner, method or mode of doing the work, and the means by which the work is to be accomplished, but without reference to having control over the results of the work. (3-23-22)

b. The freedom from direction and control must exist in theory (under a contract of service) and in fact; and (3-23-22)

c. The employer must demonstrate that it lacked a right to control the worker. (3-23-22)

04. Proving Worker Is Engaged in Independently Established Business. To meet the requirement of Section 72-1316(4)(b), Idaho Code, it must be proven that a worker is engaged in an independently established trade, occupation, profession or business. The following factors are significant and shall be considered in making this determination, although no single factor is regarded as controlling: (3-23-22)

- a. The level of skill required to perform the work; (3-23-22)
- i. A worker who performs routine tasks requiring little or no training is indicative of the worker's status as an employee. (3-23-22)
- ii. A worker who performs work requiring skills marketable as a trade, occupation, profession or business, such as an electrician, attorney, physician, or CPA, is indicative of the worker's status as an independent contractor. (3-23-22)
- iii. A worker who performs work requiring special licensing or compliance with regulatory requirements is indicative of the worker's status as an independent contractor. (3-23-22)
- iv. A worker who receives all or substantially all of the worker's job training from the alleged employer is indicative of the worker's status as an employee. (3-23-22)
- b. The extent to which the worker's services are an integral part of the alleged employer's business; (3-23-22)
- i. A worker who performs the primary type of work that the alleged employer is in business to provide to its customers or clients is indicative of the worker's status as an employee. For example, an automotive repair business hires an additional mechanic to help in its service repair shop. Since the work provided by the worker is the primary type of work the automotive repair business provides to its customers, the work is indicative of the worker's status as an employee. (3-23-22)
- ii. A worker who performs a specific job that is secondary to an integral part of the employer's business is indicative of the worker's status as an independent contractor. For example, if a manufacturing business requiring routine electrical work within its manufacturing facility hires an independent electrical company to provide that service, the electrical work performed is indicative of the worker's status as an independent contractor. (3-23-22)
- iii. A worker who supervises the alleged employer's employees is indicative of the worker's status as an employee. (3-23-22)
- iv. If the success of a business depends to an appreciable degree upon the performance of certain services, the worker performing those services is indicative of that worker's status as an employee. (3-23-22)
- v. If a worker is not required to work solely for the alleged employer and there is a separate contractual relationship for each job that ends upon the completion of that job, the work is indicative of the worker's status as an independent contractor. (3-23-22)
- c. The permanency of the relationship; (3-23-22)
- i. The longer a worker works solely for a single alleged employer, the more indicative it is of the worker's status as an employee. (3-23-22)
- ii. A worker who makes the worker's services available to the general public for hire on a regular and consistent basis is indicative of the worker's status as an independent contractor. (3-23-22)
- iii. A worker whose hours worked are regularly scheduled, rather than sporadic or occasional, is indicative of the worker's status as an employee. (3-23-22)
- iv. Work with a specific ending date that ends the working relationship between the worker and the alleged employer is indicative of the worker's status as an independent contractor. (3-23-22)
- v. Work that is open ended allowing the worker to continue working for the same alleged employer as long as performance standards are met, is indicative of the worker's status as an employee. (3-23-22)

- d. A worker's investment in facilities and equipment; (3-23-22)
- i. A worker who is reimbursed for work-related purchases, materials or supplies, or is furnished work-related materials or supplies by the alleged employer is indicative of the worker's status as an employee. (3-23-22)
- ii. A worker who uses the tools and equipment of the alleged employer is indicative of the worker's status as an employee. (3-23-22)
- iii. A worker's significant investment in tools and equipment compared to the cost of the tools and equipment provided by the alleged employer is indicative of the worker's status as an independent contractor. (3-23-22)
- iv. A worker who is financially responsible to the alleged employer for damage to equipment or tools is indicative of the worker's status as an independent contractor. (3-23-22)
- v. A worker's investment in physical facilities used by the worker in performing services is indicative of the worker's status as an independent contractor. (3-23-22)
- vi. A worker's lack of investment in physical facilities indicating a dependence on the alleged employer for whom the worker's services are performed is indicative of the worker's status as an employee. (3-23-22)
- e. Whether a worker is customarily engaged in an outside trade, occupation, profession, or business providing the same type of services the worker provides for the alleged employer engaging his services; (3-23-22)
- i. A worker who provides one (1) type of service for an alleged employer, while providing the same type of service to others for hire, is indicative of the worker's status as an independent contractor. (3-23-22)
- ii. A worker who provides one (1) type of service for an alleged employer, while providing a different type of service to others for hire, is indicative of the worker's status as an employee of the alleged employer. (3-23-22)
- iii. A worker who advertises independently via yellow pages, business cards, web pages, or other types of media is indicative of the worker's status as an independent contractor. (3-23-22)
- f. A worker's opportunities for profit and loss; (3-23-22)
- i. A worker required to carry business related expenses such as insurance, bonding, or workers compensation coverage is indicative of the worker's status as an independent contractor. (3-23-22)
- ii. A worker's ability to earn a profit by performing work more efficiently or suffer a loss because of the work performed is indicative of the worker's status as an independent contractor. (3-23-22)
- iii. A worker who is subject to a risk of economic loss due to significant investments or a bona fide liability for expenses is indicative of the worker's status as an independent contractor. (3-23-22)
- g. Other factors when viewed fairly in light of all the circumstances that may or may not indicate that the worker was engaged in an independently established trade occupation, profession, or business. These factors may include control of the premises, right to determine hours, or who sets the rate of pay. (3-23-22)

05. Meeting Criteria for Covered Employment. A worker who meets one (1), but not both, of the tests in Subsections 112.03 and 112.04 above shall be found to perform services in covered employment. (3-23-22)

06. Evidence of Contractual Liability for Termination. For purposes of making a determination under Section 72-1316(4), Idaho Code, and this regulation, the party alleging that summary termination by either party would result in contractual liability must present some evidence upon which to base such allegation. Ref.

Section 72-1316(4), Idaho Code. (3-23-22)

113. -- 130. (RESERVED)

131. FARM COMMODITY OWNERSHIP.

In determining if the farm operator-processor produced more than fifty percent (50%) of the commodities being processed, the following apply: (3-23-22)

01. Quantity. It will be determined on a quantity basis where the farm operator processes only one (1) commodity. (3-23-22)

02. Wages. It will be determined on the basis of the relationship between wages paid for processing commodities raised by the farm operator-processor and total wages paid for processing where the farm operator processes several commodities. Wages paid for processing each commodity will be determined. The proportionate share of such wages paid for processing that portion of the commodity raised by the farm operator-processor will be ascertained on the basis of the percentage of such commodity which was produced by the farm operator. This will be done for each commodity processed so as to ascertain total wages paid for processing commodities produced by the farm operator-processor. If such total is more than fifty percent (50%) of the total wages paid for processing all commodities, the activity will be exempt but if it is fifty percent (50%) or less, it will not be exempt. Ref. Section 72-1304, Idaho Code. (3-23-22)

132. STATUS.

01. Status Information Required. To determine the taxable status of an employer, detailed information regarding the business activities of any person engaged in business in Idaho shall be submitted as required, including articles of incorporation, articles of organization, minutes of boards of directors, financial reports, partnership agreements, number of employees, wages paid, employment contracts, income tax records, and any other records or other information which may tend to establish such person's status. Ref. Section 72-1337, Idaho Code. (3-23-22)

02. Notification to Liable Employers. An employer shall be notified in writing of any determination as to its liability for contributions, or its status as a covered employer if a formal determination was made after the employer questioned its status. The determination shall be in the form required by IDAPA 09.01.01.27.01, and shall become final if no timely appeal is taken to an appeals examiner pursuant to the Rules of Administrative Procedure of the Department of Labor. (3-23-22)

03. Employer Quarterly Report Forms. Employers who are liable to pay tax contributions, or who have elected a cost reimbursement option in lieu of tax contributions, shall submit quarterly report forms in any form or medium designated by the director or his authorized representative. Ref. Section 72-1349, Idaho Code. (3-23-22)

04. Update Requirements. Covered employers shall furnish the Department with pertinent status data when new or additional information is available. Ref. Section 72-1337, Idaho Code. (3-23-22)

133. (RESERVED)

134. PROFESSIONAL EMPLOYER ORGANIZATIONS.

A professional employer organization shall fully comply with the requirements of the Professional Employer Recognition Act, Chapter 24, Title 44, Idaho Code in order to be eligible for any transfers of experience rating as allowed by Section 72-1349B, Idaho Code. (3-23-22)

01. Methods of Reporting. To report the wages and employees covered by the professional employer arrangement between a professional employer and client, professional employers and their clients shall make reports to the Department in one (1) of the following ways, subject to the conditions in Subsections 134.02 through 134.06 of this rule: (3-23-22)

a. Report the workers included in the professional employer arrangement under the employer account number of the professional employer and transfer the rate of the client to the professional employer; or (3-23-22)

b. Report the workers included in the professional employer arrangement under the employer account number of the client without an experience rate transfer. Ref. Section 72-1349B, Idaho Code. (3-23-22)

02. Joint Transfer of Experience Rate. In order to effect a transfer of a client's experience rate into the experience rate of a professional employer organization, both the client and the professional employer organization shall jointly apply for the transfer of the experience rate within the same timeframes as required of employers by Section 72-1351(5), Idaho Code, from the date of the contract entered into between the professional employer organization and the client required by Section 44-2405, Idaho Code. Failure to submit a timely joint request for transfer of experience rate shall result in the professional employer organization reporting wages for the client under the employer account number of the client. Ref. Section 72-1351(5), Idaho Code. (3-23-22)

03. Partial Transfers of Experience Rate Prohibited. In the event that a client and a professional employer organization jointly apply to transfer the experience rate of the client into that of the professional employer, the client's entire experience rate and factors of experience rate shall be transferred into that of the professional employer, and no partial transfers of experience factors or the experience rate shall be allowed. Ref. Section 72-1349B, Idaho Code. (3-23-22)

04. Partial Reporting of Workers. If some of the client's workers are included in the professional employer arrangement and some are not included, and the professional employer organization and the client elect to report the workers included in the professional employer arrangement under the employer account number of the client, then only one (1) quarterly report shall be remitted to the Department, which shall list or include all the client's workers whether or not included in the professional employer arrangement. Ref. Section 72-1349B, Idaho Code. (3-23-22)

05. Combined Wages or Services for Purposes of Coverage. If a client employer has employees or employment, or both, that does not independently meet the coverage or threshold requirements necessary to constitute covered employment, such employees, services or employment shall nonetheless be deemed to meet the coverage requirements of the Employment Security Law if, in combination with other employees, employment or services of such other employees of the professional employer organization or any of its clients, such wages, services or employees do jointly meet coverage requirements. (3-23-22)

135. -- 165. (RESERVED)

166. FIELD OPERATIONS CONTROL.

When circumstances dictate, and as a result of nonpayment of liabilities, the employer shall be notified by mail to the last known address of lien proceedings against the employer's interests, with an explanation of the amounts due, and the accrual of interest at the proper rate until the lien is satisfied. Ref. Section 72-1360, Idaho Code. (3-23-22)

01. Limitation for Commencing Administrative Procedures. The director may commence an administrative proceeding for purposes of establishing a tax liability, or otherwise to enforce the provisions of Section 72-1349, Idaho Code, by issuing a determination at any time within five (5) years from the due date of a quarterly report or the date a quarterly report is filed, whichever is later, subject to tolling pursuant to Section 72-1349, Idaho Code. (3-23-22)

a. Notification of Audits. Employers shall be notified as soon as practicable of an impending payroll records audit for tax liability purposes. This shall allow time in which to agree as to a convenient time and place for audit. Ref. Section 72-1337, Idaho Code. (3-23-22)

b. Frequency of Audits. The frequency of audits or inspections of an employer's records to ensure compliance with the law and Department rules shall be based on the following criteria: (3-23-22)

i. On the basis of random selection and other selection criteria in accordance with federal requirements; (3-23-22)

ii. As a result of information received from any source, provided that the information received is of such a nature that it would be reasonable to conduct an audit or inspection of records as a result of that information; or

(3-23-22)

iii. As a result of a previous audit, if the business practices or records of the employer are of such a nature that it would be reasonable for a Department employee to re-inspect or re-audit the records to ensure future compliance with the law. Ref. Section 72-1337, Idaho Code. (3-23-22)

02. Execution Against Assets. The Department of Labor, when the situation warrants, shall levy upon or execute against any real or personal property, both tangible and intangible, in which an indebted person has an interest, including any offsets as allowed by Section 67-1026, Idaho Code. Ref. Section 72-1360, Idaho Code. (3-23-22)

03. Relief of Indebtedness. Neither the full running of the statute of limitations nor the writing off of the account as uncollectible relieves an employer of tax indebtedness. Ref. Section 72-1364, Idaho Code. (3-23-22)

167. -- 185. (RESERVED)

186. ACCOUNTING AND DELINQUENCY CONTROL.

Overpayments on employer accounts may be refunded without written application by the employer. Credits resulting from overpayments or adjustments to an employer's account shall be refunded periodically unless such credit is applied to a subsequent balance due. Ref. Section 72-1357, Idaho Code. (3-23-22)

01. Erroneous Wage Reports. An employer submitting an erroneous report of employee wages resulting in payment of unearned unemployment insurance benefits shall have said benefit payments subtracted from any refund due that employer, if such employer benefited from the unearned benefit payments. Ref. Section 72-1372, Idaho Code. (3-23-22)

02. Notification of Underpayments. Employers shall be notified periodically of any taxes, penalties, or lien interest due on their tax account. Ref. Section 72-1349, Idaho Code. (3-23-22)

03. Cancellation of Refund Warrants. Refund warrants, outstanding after the validity date, shall be canceled, stop-payment procedures initiated, and then reissued only upon completion of an affidavit for the replacement of the lost or destroyed warrant. Ref. Section 72-1357, Idaho Code. (3-23-22)

187. -- 220. (RESERVED)

221. TRANSFER OF EXPERIENCE RATING.

Upon request, employers shall be informed of the requirements for transferring an experience rating record. Notification shall be issued to interested parties when an experience rating record transfer request is made. Ref. Sections 72-1351 and 72-1351A, Idaho Code. (3-23-22)

01. Mandatory Transfer of Rate. An experience rating record transfer shall be mandatory if there is a transfer of trade or business and ownership or management or control is substantially the same between the predecessor and successor. The parties in interest shall be notified of such transfer of experience as determined from the facts applicable to the case. The determination shall be in the form required by IDAPA 09.01.01.027.01, and become final if no appeal is taken to an appeals examiner pursuant to the Rules of Administrative Procedure of the Department of Labor. (3-23-22)

02. Partial Experience Rate Transfers. The following method is used to compute the pro-rata share of the experience rate account that is to be transferred from the predecessor to a successor. The pro-rata share is determined by dividing the gross payroll associated with the portion of the business acquired by the total gross payroll for the entire business operations for the same time period. The time period upon which this computation is based is the four (4) most recently completed quarters as reported by the predecessor prior to the date of acquisition or change in entity. (3-23-22)

03. Continued Predecessor Employment for Liquidation. When a total transfer of experience rating record has been completed and it is found that the predecessor employer continues to have employment in connection with the liquidation of his business, such employer shall continue to pay contributions at the assigned rate for the

period of liquidation but not to extend beyond the balance of the rate year. Ref. Section 72-1351, Idaho Code. (3-23-22)

04. Management or Ownership or Control Substantially the Same. For the purposes of Subsection 72-1351A, Idaho Code, in determining whether the ownership or management or control of a successor is substantially the same as the ownership or management or control of the predecessor factors to be considered include, but are not limited to, the extent of policy making authority, the involvement in daily management of operations, the supervision over the workforce, the percentage of ownership of shares or assets, and the involvement on boards of directors or other controlling bodies. (3-23-22)

05. Wage Paid by Predecessor. The successor employer may use wages paid by the predecessor employer to arrive at the wage base for purposes of calculating taxable wages only when the experience rate of a predecessor employer has been transferred to a successor employer. Ref. Sections 72-1349(1), 72-1351(5), and 72-1350(8), Idaho Code. (3-23-22)

222. -- 230. (RESERVED)

231. EXPERIENCE RATING -- QUALIFYING PERIOD.

When an eligible employer ceases to have covered employment for a period of six (6) consecutive quarters or more, they must complete another qualifying period in order to again be eligible for consideration for a reduced contribution rate. Ref. Section 72-1319, Idaho Code. (3-23-22)

232. -- 240. (RESERVED)

241. BOARD, LODGING, MEALS.

When board, lodging, meals, or any other payment in kind considered as payment for services performed by an employee constitute a part of wages or wholly comprise an employee's wages, the value of such board, lodging, or other payment shall be determined as follows: (3-23-22)

01. Cash Value. If a cash value for such board, lodging, or other payment is agreed upon in any contract of hire, the amount so agreed upon shall be used provided it is a reasonable, fair market value. If there is no agreement, or if the contract of hire states an amount less than a reasonable, fair market value, the Department of Labor shall determine the reasonable or fair market value to be used. Ref. Section 72-1328, Idaho Code. (3-23-22)

02. Meals and Lodging Not Included in Gross Wages. The value of meals and lodging furnished by an employer to the employee will not be included in the employee's gross income if it meets the following tests: (3-23-22)

a. The meals or lodging are furnished on the employer's business premises; (3-23-22)

b. The meals or lodging are furnished for the employer's convenience; and (3-23-22)

c. In the case of lodging (but not meals), the employees must be required to accept the lodging as a condition of their employment. This means that they must accept the lodging to allow them to properly perform their duties. (3-23-22)

d. In order to exclude the value of lodging from an employee's gross wages, the employer must show that the wages paid to the employee for services performed meets the prevailing wage for those services. If the employer's records do not show or establish that the employee received the prevailing wage for services performed, then the reasonable or fair market value of the lodging will be included in the employee's gross income as wages. Ref. Section 72-1328, Idaho Code. (3-23-22)

03. Meals or Lodging for Employer Convenience. Meals or lodging furnished will be considered for the employer's convenience if the employer has a substantial business reason other than providing additional pay to the worker. A statement that the meals or lodging are not intended as pay is not enough to prove that either meals or lodging are furnished for the employer's convenience. Ref. Section 72-1328, Idaho Code. (3-23-22)

04. Subsistence Remuneration. In the case of employees who receive remuneration in the form of subsistence, such as groceries, staples, and fundamental shelter, the fair value of such subsistence will be determined by the Director. Ref. Section 72-1328, Idaho Code. (3-23-22)

242. -- 255. (RESERVED)

256. DETERMINATION OF FAIR VALUE OF REMUNERATION FOR PERSONAL SERVICES.

When the amount paid to an employee by an employer includes remuneration for other than personal services such as equipment use, travel costs, etc., the Director shall determine the fair value of the remuneration for the employee's personal services. In making such determination, the Director shall consider the wages specified in the contract of hire, the prevailing wages for similar work under comparable conditions, and other pertinent factors. The wages so determined by the Director shall be reported by the employer. Ref. Section 72-1328, Idaho Code. (3-23-22)

257. -- 261. (RESERVED)

262. DETERMINATION OF PROPER QUARTER IN WHICH TO ASSIGN AND REPORT WAGES.

01. Wage Assignment to Proper Calendar Quarter. Wages paid shall be assigned to the calendar quarter in which the wages were: (3-23-22)

a. Actually paid to the employee in accordance with the employer's usual and customary payday as established by law or past practice; or (3-23-22)

b. Due the employee in accordance with the employer's usual and customary payday as established by law or past practice but not actually paid on such date because of circumstances beyond the control of the employer or the employee; or (3-23-22)

c. Not paid on the usual or customary payday as established by law or past practice but set apart on the employer's books as an amount due and payable or otherwise recognized as a specific and ascertainable amount due and payable to the worker in accordance with an agreement or contract of hire under which services were rendered. Ref. Section 72-1367, Idaho Code. (3-23-22)

02. Draws and Advances on Wages. Payments to employees made prior to regular or established paydays will be assignable and reportable during the quarter in which they would have been paid unless a practice is established whereby all employees or a class of employees are given an opportunity to take a "draw" by which such action, another "regular" payday appears to have been created. (3-23-22)

03. Judgments of Wages. Amounts received as a result of labor relations awards or judgments for back pay, or for disputed wages, constitute wages and will be reported in the quarter or quarters in which the award or judgment has become final, after all appeals have been exhausted, or the quarter or quarters to which the court assigns the wages, if different. Ref. Section 72-1328, Idaho Code. (3-23-22)

04. Awarded Damages Against Employers. Amounts awarded to the claimant as a penalty or damages against the employer, other than for lost wages, do not constitute wages. Ref. Section 72-1328, Idaho Code. (3-23-22)

263. DETERMINATION OF REPORTABLE QUARTERS.

An employer shall be covered for all four (4) quarters in the calendar year in which the employer becomes a covered employer as well as for all four (4) quarters in the succeeding calendar year. Employers are not required to file quarterly reports until meeting the coverage criteria pursuant to Section 72-1315, Idaho Code. Upon becoming a covered employer within a calendar year, the quarterly report(s) for the quarter(s) prior to the employer becoming covered shall be filed with the quarterly report for the quarter in which the employer became covered. Quarterly reports for the periods subsequent to coverage shall be filed when due after the end of each quarter. Ref. Sections 72-1315 and 72-1337, Idaho Code. (3-23-22)

264. -- 999. (RESERVED)

**IDAPA 11 – IDAHO STATE POLICE
STATE FORENSIC LABORATORY**

**11.03.01 – RULES GOVERNING ALCOHOL TESTING
DOCKET NO. 11-0301-2401 (ZBR CHAPTER REWRITE)
NOTICE OF RULEMAKING – PROPOSED RULE**

AUTHORITY: In compliance with Section 67-5221(1), Idaho Code, notice is hereby given that this agency has initiated proposed rulemaking procedures. The action is authorized pursuant to Section(s) 67-2901, Idaho Code.

PUBLIC HEARING SCHEDULE: A public hearing concerning this rulemaking will be held as follows:

11.03.01 – Rules Governing Alcohol Testing
Thursday, October 3rd, 2024 – 10:00 a.m. (MT) Idaho State Police, District 3 700 S Stratford Drive Meridian, ID 83642
Virtual Link Dial in by Phone: 1-872-215-6990 Conference ID 485 988 928#

The hearing site(s) will be accessible to persons with disabilities. Requests for accommodation must be made not later than five (5) days prior to the hearing, to the agency address below.

DESCRIPTIVE SUMMARY: The following is a nontechnical explanation of the substance and purpose of the proposed rulemaking:

These rules are being presented for authorization as part of the Idaho State Police’s plan to review each rule every five years. The goal is to perform a comprehensive review of and update, streamline, and modernize these rules consistent with the Governor’s [Executive Order 2020-01: Zero Based Regulation](#). The Idaho State Police intends to carefully consider all changes presented by the public and may propose certain changes so long as they are consistent with the rules’ stator authority and the Governor’s Executive Order.

FEE SUMMARY: The following is a specific description of the fee or charge imposed or increased:

There are no fees associated with this rulemaking.

FISCAL IMPACT: The following is a specific description, if applicable, of any negative fiscal impact on the state General Fund greater than ten thousand dollars (\$10,000) during the fiscal year as a result of this rulemaking: N/A.

NEGOTIATED RULEMAKING: Pursuant to Section 67-5220(1), Idaho Code, negotiated rulemaking was conducted. The Notice of Intent to Promulgate Rules - Negotiated Rulemaking was published in the August 7, 2024, Idaho Administrative Bulletin, [Vol. 24-8, p 40](#).

INCORPORATION BY REFERENCE: Pursuant to Section 67-5229(2)(a), Idaho Code, the following is a brief synopsis of why the materials cited are being incorporated by reference into this rule:

ASSISTANCE ON TECHNICAL QUESTIONS, SUBMISSION OF WRITTEN COMMENTS: For assistance on technical questions concerning the proposed rule, contact Matthew Gamette, (208) 884-7217, email – matthew.gamette@isp.idaho.gov.

Anyone may submit written comments regarding this proposed rulemaking. All written comments must be directed to the undersigned and must be delivered on or before October 23, 2024.

DATED this 23rd day of August, 2024.

Colonel Bill Gardiner, Director
Idaho State Police
700 S Stratford Drive
Meridian ID 83642
(208) 884-7004
Bill.gardiner@isp.idaho.gov

THE FOLLOWING IS THE PROPOSED TEXT OF DOCKET NO. 11-0301-2401
(ZBR Chapter Rewrite)

11.03.01 – RULES GOVERNING ALCOHOL TESTING

000. LEGAL AUTHORITY.

The Director of the Idaho State Police has general rulemaking authority to prescribe rules and regulations for alcohol testing, pursuant to Section 67-2901, Idaho Code. (3-23-22)

001. SCOPE.

01. Scope. The rules relate to the governance and operation of the Alcohol Testing Program. (3-23-22)

002. INCORPORATION BY REFERENCE.

The following are incorporated by reference in this chapter of rules: (3-23-22)

01. Conforming Products List of Evidential Breath Measurement Devices (revised 11/2/2017).
This document is available on the Internet at <https://www.gpo.gov/fdsys/pkg/FR-2017-11-02/pdf/2017-23869.pdf>. (3-23-22)

003. -- 009. (RESERVED)

010. DEFINITIONS AND ABBREVIATIONS.

01. Alcohol. The chemical compounds of ethyl alcohol, methyl alcohol, or isopropyl alcohol. (3-23-22)

~~**02. Approved Vendor.** A source/provider/manufacture of an approved standard. (3-23-22)~~

~~**03. Blood Alcohol Analysis.** An analysis of breath, blood, or urine to determine the concentration of alcohol present. (3-23-22)()~~

~~**04. Breath Alcohol Analysis.** An analysis of breath to determine the concentration of alcohol present. (3-23-22)~~

~~**05. Breath Alcohol Test.** A breath sample or series of separate breath samples provided during a breath testing sequence(s). (3-23-22)~~

~~**06. Breath Alcohol Testing Sequence.** A sequence of events as determined by the Idaho State Police Forensic Services, which may be directed by the instrument, the Operator, or both, and may consist of air blanks, performance verification, internal standard checks, and breath samples. (3-23-22)~~

~~07. **Breath Testing Specialist (BTS).** An operator who has completed advanced training approved by the department and are certified to perform routine instrument maintenance, teach instrument operation skills, proctor proficiency tests for instrument Operators, and testifying as an expert on alcohol physiology and instrument function in court. (3-23-22)~~

084. Calibration. A set of laboratory operations which establish under specified conditions, the relationship between values indicated by a measuring instrument or measuring system, or values represented by a material, and the corresponding known values of a measurement. (3-23-22)

~~09. **Certificate of Analysis.** A certificate stating the standards used for performance verification have been tested and approved for use by the ISPFS or are manufactured by an ISO 17025:2005, 17025:2017, (or equivalent standard) vendor and are traceable to N.I.S.T. standards. (3-23-22)~~

~~10. **Certificate of Instrument Calibration.** A certificate stating that an individual breath alcohol testing instrument has been evaluated by the ISPFS and found to be suitable for forensic alcohol testing. The certificate bears the signature of the calibration analyst at Idaho State Police Forensic Services, and the effective date of the instrument approval. (3-23-22)~~

~~105. **Department.** The Idaho State Police. (3-23-22)~~

~~1206. **Deprivation Period.** A minimum time period of fifteen (15) minutes immediately prior to evidentiary breath alcohol testing during which the subject individual is not to be allowed to smoke, drink, or eat substances containing alcohol. (3-23-22)()~~

~~1307. **Evidentiary Test.** A blood, breath, or urine test performed on a subject individual for potential evidentiary or legal purposes. A distinction is made between evidentiary testing and non-quantitative screening/monitoring. (3-23-22)()~~

~~1408. **Idaho State Police Forensic Services (ISPFS).** A division of the Idaho State Police. ISPFS is dedicated to providing forensic science services to the criminal justice system of Idaho. ISPFS is the administrative body for the alcohol testing programs in Idaho. (3-23-22)~~

~~1509. **Laboratory.** The place at which specialized devices, instruments and methods are used by trained personnel to measure the concentration of alcohol in samples of blood, vitreous humor, urine, or beverages for law enforcement purposes. (3-23-22)~~

~~16. **MIP/MIC.** An abbreviation used to designate minor in possession or minor in consumption of alcohol. (3-23-22)~~

~~170. **Monitoring Period.** A minimum time period of fifteen (15) minutes immediately prior to evidentiary breath alcohol testing. The monitoring period consists of a mandatory deprivation period and discretionary observation period. The observation period becomes mandatory if the numeric results from only a single breath sample are used. (3-23-22)~~

~~181. **Observation Period.** The time period running concurrently with the deprivation period in which the officer(s) should be observing the subject individual, and any belch/burp/vomit/regurgitation should be noted by the operator(s). The officer(s) should be in a position, either physically or remotely, to be able to ~~use their available senses to~~ detect the aforementioned events. (3-23-22)()~~

~~192. **Operator Certification.** ~~The condition of having satisfied the t~~ Training requirements for administering breath alcohol tests as established by the department. (3-23-22)()~~

~~2013. **Operator.** An individual certified by the department as qualified by after completion of Breath Test Operator or Breath Test Specialist training to administer breath alcohol tests. (3-23-22)()~~

~~214. **Performance Verification.** ~~A verification of the a~~ Accuracy check of the breath testing instrument~~

utilizing a performance verification standard. ~~Performance verification should be~~ reported to three decimal places. ~~While ISPFPS uses the term performance verification, manufacturers and others may use a term such as~~ Synonymous with terms “calibration check” or “simulator check.” (3-23-22)()

2215. Performance Verification Standard. An ethyl alcohol standard used for field performance verifications. The standard is provided or approved, or both, by the department. (3-23-22)

2316. Proficiency Testing. A periodic analysis ~~of blood, urine, or other liquid specimen(s) whose alcohol content is unknown to the testing laboratory,~~ to evaluate the capability of ~~that~~ a laboratory to perform accurate analysis for alcohol concentration. (3-23-22)()

2417. Quality Control. An analysis of referenced ~~samples whose alcohol content is known, which is performed with each batch of blood, vitreous humor, urine or beverage analysis~~ to ensure ~~that the laboratory’s determination of alcohol concentration is reproducible and accurate~~ reproducibility and accuracy of the results. (3-23-22)()

~~25. Urine Alcohol Analysis.~~ An analysis of urine ~~to determine the concentration of alcohol present.~~ (3-23-22)

18. Testing Sequence. A sequence of events as determined by the Idaho State Police Forensic Services, which may be directed by the instrument, the Operator, or both, and may consist of air blanks, performance verification, internal standard checks, and breath samples. ()

011. – 012. (RESERVED)

013. REQUIREMENTS FOR LABORATORY ALCOHOL ANALYSIS.

01. Laboratory. Any laboratory desiring to perform urine alcohol, vitreous humor, blood alcohol, or beverage analysis shall meet the following standards: (3-23-22)

a. Prepare and maintain a written procedure governing its method of analysis, including guidelines for quality control and proficiency testing. A copy of the procedure shall be provided to ISPFPS for initial approval. Whenever procedure, protocol, or method changes (however named) are adopted by a laboratory, a copy of the update with the changes clearly indicated shall be approved by ISPFPS before implementation; (3-23-22)

b. Provide adequate facilities and space for the procedure used. The laboratory alcohol related functions shall be subject to an assessment by either an accrediting body or the department each calendar year, and the results from the annual audit shall be submitted to the department. The assessment shall be at the expense of the laboratory; (3-23-22)

c. Maintain specimens in a limited access and secure storage area prior to analysis. A chain of custody shall be maintained while the evidence is in the laboratory; (3-23-22)

d. All instrumentation, equipment, reagents and glassware necessary for the performance of the chosen procedure shall be on hand or readily available on the laboratory premises. Instrument maintenance documentation shall be available for review by the department; (3-23-22)

e. Participate in approved proficiency testing ~~and pass this proficiency testing~~ according to standards set by the department. Laboratories must ~~participate in~~ pass proficiency testing from a department approved provider at least once a calendar year. Approved providers include National Highway Traffic Safety Administration (NHTSA) and Collaborative Testing Services (CTS). Each test consists of at least four (4) blood samples spiked with an unknown concentration of ethyl alcohol, and possibly other volatiles, for qualitative determination. Participating laboratories ~~must obtain proficiency tests from approved providers and~~ are responsible for all costs associated with ~~obtaining and analyzing~~ such tests. Results from proficiency tests must be submitted by the due date to the test provider and ISPFPS. Results not submitted to a test provider within the allowed time do not qualify as a proficiency test. An alcohol concentration range is determined from the target value and ± 3.0 standard deviations as provided by the proficiency test provider. Reported values must fall within this range. If a laboratory determines more than one (1)

alcohol value for a given sample, the mean value of results will be submitted and evaluated. Upon satisfactory completion of an approved proficiency test, a certificate of approval will be issued by the department to the participating laboratory. Approval to perform legal blood alcohol determinations is continued until the results of the next proficiency test are reviewed and notification is sent to the respective laboratory by ISPFs. Failure to pass a proficiency test shall result in immediate suspension of testing by an analyst or laboratory in the form of a written inquiry from the department. The test is graded as unsuccessful when the mean results are outside the established tolerance range ~~established from the accepted mean values~~. The laboratory shall have thirty (30) calendar days to respond to the department inquiry. The department shall notify the laboratory within fourteen (14) calendar days regarding corrective action steps necessary to lift the testing suspension, or the department may issue a written revocation. The department shall not lift a proficiency testing related suspension or revocation until a successful proficiency test has been completed by the individual analyst or laboratory. (3-23-22)()

~~f. For a laboratory performing blood, urine, vitreous humor, or beverage analysis for alcohol, approval shall be~~ Laboratory approval is awarded to the laboratory ~~director manager~~ or primary analyst responsible for that laboratory correct test performance. ~~The responsibility for the correct performance of tests in that laboratory rests with that person; however, the duty of performing such tests may be delegated to any person designated by such director or primary analyst.~~ The department may ~~temporarily~~ suspend or ~~permanently~~ revoke ~~the approval of a laboratory or analyst~~ if the listed requirements are not met. The department will issue the suspension or revocation in writing to the laboratory ~~director or primary analyst responsible~~; (3-23-22)()

~~g02. Appeal~~ Reinstatement after revocation requires completed corrective action of any items listed on the revocation documentation issued by the department. Documentation of corrective actions taken to address the nonconformities shall be submitted to the department for review. Once the department is satisfied that the laboratory is in compliance with all requirements, the department will issue written approval for the resumption of testing by that laboratory or analyst. A laboratory may appeal a suspension or revocation to the Director of the department. (3-23-22)()

~~02. Blood Collection.~~ Blood collection shall be accomplished according to the following requirements: (3-23-22)

~~a03. Blood Samples.~~ shall be collected using sterile, dry syringes and hypodermic needles, or other equipment of equivalent sterility; (3-23-22)

~~b.~~ The ~~skin at the area of~~ puncture area shall be ~~cleansed thoroughly and~~ disinfected with an aqueous ~~solution of a~~ nonvolatile antiseptic. Alcohol or phenolic solutions shall not be used as a skin antiseptic; (3-23-22)()

~~ea.~~ Blood specimens shall contain at least ten (10) milligrams of sodium fluoride per cubic centimeter ~~of blood~~ plus an ~~appropriate~~ anticoagulant. (3-23-22)()

~~034. Blood Reported.~~ The ~~r~~ Results of analysis ~~on blood~~ for alcohol concentration shall be reported in units of grams of alcohol per one hundred (100) cubic centimeters of whole blood. (3-23-22)()

~~045. Urine Collection.~~ Urine samples shall be collected in clean, dry containers. (3-23-22)

~~056. Urine Reported.~~ The ~~results of analysis on urine~~ Results for alcohol concentration shall be reported in ~~units of~~ grams of alcohol per sixty-seven (67) milliliters ~~of urine.~~ Results of alcohol analysis of urine specimens shall be accompanied by a warning statement about the questionable value of urine alcohol results, with a warning about the questionable value of urine alcohol results. (3-23-22)()

~~067. Records.~~ All records regarding proficiency tests, quality control and results shall be retained for three (3) years. (3-23-22)

014. REQUIREMENTS FOR PERFORMING BREATH ALCOHOL TESTING.

~~01. Instruments.~~ Each breath testing ~~i~~ Instrument models incorporated by reference in Section 02.01 of this rule shall be approved by the department ~~and be listed in the "Conforming Products List of Evidential Breath~~

~~Measurement Devices” published in the Federal Register by the United States Department of Transportation as incorporated by reference in Section 002 of this rule. The department will maintain a list of benchtop and portable instruments approved for evidentiary testing use in Idaho. Each individual breath testing instrument must be certified by the department. The department may revoke instrument approval, for cause, remove a specific instrument by serial number from evidential testing and suspend or withdraw certification thereof. (3-23-22)()~~

02. Report. Each direct breath testing instrument shall report alcohol concentration as grams of alcohol per two hundred ten (210) liters of breath. (3-23-22)

03. Administration. ~~Breath tests shall be administered in conformity with standards established by the department~~ Breath tests must be administered by a certified operator and follow department standards. Standards shall be developed for each type of breath testing instrument used in Idaho, and such standards shall be issued in the form of Idaho administrative rules, ISPFs analytical methods, and ISPFs standard operating procedures. (3-23-22)()

~~a. The breath alcohol test must be administered by an operator (BTO or BTS) currently certified in the use of the instrument.~~ (3-23-22)

ba. Prior to administering the monitoring period, any foreign objects/materials which have the potential to enter the instrument/breath tube or may present a choking hazard (e.g. gum, chewing tobacco, food) should be removed. (3-23-22)

eb. The operator shall administer a monitoring period prior to evidentiary testing. (3-23-22)

ed. If mouth alcohol is suspected or indicated by the testing instrument, the operator shall ~~begin another fifteen (15) minute~~ restart the monitoring period if repeating the testing sequence. If during the monitoring period the subject/individual vomits or regurgitates material from the stomach into the breath pathway, the monitoring period should start over. If there is doubt as to the events occurring during the monitoring period ~~(e.g. silent burp, belch, vomit, regurgitation)~~, the operator should evaluate the instrument results for any indication of mouth alcohol. (3-23-22)()

ed. A complete breath alcohol test includes two (2) valid breath samples, preceded by air blanks, taken ~~during the testing procedure and preceded by air blanks. The breath samples performed with a portable breath testing instrument should be~~ approximately two (2) minutes apart or more. If the subject/individual fails or refuses to provide two (2) adequate samples as requested by the operator, ~~the test result of a single adequate sample result~~ shall be considered a valid. ~~If a single test result is used, then test if~~ the observation ~~criteria of the monitoring period (observation period)~~ is mandatory met. For hygienic reasons, the operator should use a new mouthpiece for each subject/individual tested. (3-23-22)()

fe. ~~The operator has the discretion to end breath testing, repeat breath testing, or request a blood draw at any point during the testing process as the circumstances require (including but not limited to lack of sample correlation, lack of subject participation or cooperation, subject is incoherent or incapable of following instructions, subject incapacitation)~~ Operators may end testing, repeat testing, or request a blood draw as needed. If a subject/individual fails or refuses to provide adequate samples as requested by the operator, the results obtained are ~~still~~ considered valid, provided the failure to supply the ~~requested~~ samples was the fault of the subject/individual and not the operator. (3-23-22)()

gf. ~~A third~~ Additional breath samples shall, when possible, be collected if the ~~first two (2)~~ results differ by more than 0.02 g/210L alcohol. Unless mouth alcohol is indicated or suspected, it is not necessary to repeat the monitoring period prior to obtaining ~~a third~~ additional breath samples. (3-23-22)()

hg. ~~The results for~~ breath samples results should correlate within 0.02 g/210L alcohol to show consistent sample delivery, indicate the absence of RFI, and to indicate the absence of alcohol contamination in the subject/individual's breath pathway as a contributing factor to the breath results. (3-23-22)()

ih. In the event of an instrument failure, the operator should attempt to utilize another instrument or have blood drawn. (3-23-22)

04. **Training.** Each ~~individual~~ operator (~~BTO or BTS~~) shall ~~demonstrate sufficient training to operate the instrument correctly. This shall be accomplished by~~ successfully ~~completing~~ complete a training course approved by the department on each instrument model ~~utilized by the operator used.~~ Operator certifications ~~issued after July 1, 2013~~ are valid for two (2) ~~calendar~~ years from the course completion date. The department may revoke ~~individual operator (BTO/BTS)~~ certification for cause. (3-23-22)()

05. **Performance Verification Checks.** Each ~~breath testing~~ instrument shall be checked for accuracy with an approved performance verification standard ~~approved by the department.~~ Performance verification checks shall be performed and documented according to a procedure established by the department ~~and be documented.~~ The official time and date of the performance verification is the time and date recorded on the printout, or the time and date recorded in the log. (3-23-22)()

a. A performance verification check shall occur within twenty-four (24) hours before or after an evidentiary test. ~~The benchtop instrument requires a performance verification check as part of the testing sequence. On the~~ For portable instruments, multiple breath alcohol tests may be covered by a single performance verification. (3-23-22)()

b. A performance verification on a portable instrument consists of two (2) samples at either the 0.08 or 0.20 level. Both samples must be run with the same performance verification standard. Three (3) attempts at obtaining an acceptable performance verification are allowed. Troubleshooting measures may be employed during this process. If the ~~third performance~~ verifications ~~fails,~~ the instrument shall be taken out of service and not be returned to service until it has been calibrated and certified by ISPFS. (3-23-22)()

c. A performance verification acquired during a breath testing sequence on an approved benchtop instrument consists of one (1) sample at either the 0.08 or 0.20 level. A performance verification acquired outside the breath testing sequence on an approved benchtop instrument consists of two (2) samples at either the 0.08 or 0.20 level. Three (3) attempts at obtaining an acceptable performance verification are allowed. Troubleshooting measures may be employed during this process. If the ~~third performance~~ verifications ~~fails,~~ the instrument must be taken out of service and not be returned to service until it has been calibrated and certified by ISPFS. (3-23-22)()

d. Performance verification checks must be within +/- 10% of the ~~performance verification~~ standard's target value. (3-23-22)()

e. A wet bath 0.08 ~~performance verification~~ standard should be replaced with fresh standard approximately every twenty-five (25) verifications or every calendar month, whichever comes first. ~~For a e C~~losed loop, recirculating system ~~(e.g. the Intox 5000 series), the 0.08 performance verification standard should be replaced with fresh standards~~ approximately every one hundred (100) verifications or every calendar month, whichever comes first. (3-23-22)()

f. ~~A w~~Wet bath 0.20 ~~performance verification~~ standards ~~s~~ should be replaced with fresh standard approximately every twenty-five (25) verifications. (3-23-22)()

g. Dry gas ~~performance verification~~ standards may be used continuously ~~without replacement~~ until ~~the canister is spent or the expiration date is reached~~ expired. (3-23-22)()

h. ~~Performance verification s~~Standards should not be used beyond the expiration date. (3-23-22)()

i. If Section 18-8004C, Idaho Code, ~~(excessive alcohol concentration)~~ is applicable, ~~then~~ a 0.20 performance verification must be run and ~~results~~ documented once per calendar month. Failure to perform ~~a 0.20 performance verification this~~ will not invalidate any tests where Section 18-8004C, ~~Idaho Code,~~ is not applicable. A ~~performance verification with a 0.20 standard performance verification~~ does not need to be performed within twenty-four (24) hours of an ~~evidentiary~~ breath test in excess of 0.20 g/210L alcohol. (3-23-22)()

j. ~~Temperature of the w~~Wet bath simulator temperature shall be between thirty-three point five degrees Celsius (33.5°C) and thirty-four point five degrees Celsius (34.5°C) ~~in order for the performance verification~~

~~results to be for~~ valid results. (3-23-22)()

- k. An agency may run additional performance verification ~~standard~~ levels at their discretion. (3-23-22)()

06. **Records.** Operators must document and retain test results (i.e. written log, printout, or electronic database). ~~All records regarding and maintenance and results shall be retained records~~ for three (3) years. ISPFS is not responsible for ~~storage of documentation not generated by ISPFS~~ storing non-ISPFS documentation. (3-23-22)()

07. **Deficiencies.** Failure to meet ~~any of the conditions listed~~ in Sections 013 and 014. ~~Any laboratory or breath testing instrument may be disapproved for failure to meet one (1) or more of the requirements listed in Sections 013 and 014, and approval may be withheld until the deficiency is corrected~~ lead to disapproval of any laboratory or breath testing instrument until corrected. (3-23-22)()

08. **Standards.** ~~Premixed alcohol simulator solutions shall~~ An approved standard shall be from ~~an approved vendor~~ a source, provider, or manufacturer of an approved standard and explicitly approved ~~in writing~~ by the department ~~before distribution within Idaho~~. ~~Dry gas s~~ Standards from ISO ~~17025:2005~~ 17034 (or equivalent) certified providers are ~~explicitly approved by the department for use in Idaho~~ without department evaluation ~~by the department~~. (3-23-22)()

09. **MIP/MIC** Minor in Possession or Minor in Consumption (MIP/MIC). ~~The p~~ Presence or absence of alcohol ~~is the determining factor in~~ determines the evidence in ~~an~~ MIP/MIC cases. The instrumentation used in obtaining the breath sample is often the same instrumentation utilized for acquiring DUI evidence. The different standard of evidence requires different standards for the procedure. The administration of a MIP/MIC breath test should follow section 14.03 with the following exceptions: (3-23-22)()

a. ~~Fifteen (15) minute monitoring period: The monitoring period is not required for the MIP/MIC procedure~~ A fifteen (15) minute monitoring period is required before retesting if mouth alcohol is suspected. (3-23-22)()

b. The breath alcohol test must be administered by an operator currently certified in the use of that instrument. (3-23-22)

c. The instrument used must be initially certified by ISPFS. ~~The instrument only needs to be initially certified by ISPFS. Initial certification shows that the instrument responds to alcohols and not to acetone.~~ The instrument does not need to be checked regularly or periodically with any of the 0.08 or 0.20 standard. (3-23-22)()

~~d.~~ ~~The officer should have the individual being tested remove all loose foreign material from their mouth before testing. False teeth, partial plates, or bridges installed or prescribed by a dentist or physician do not need to be removed to obtain a valid test. The officer may allow the individual to briefly rinse their mouth out with water prior to the breath testing. Any alcohol containing material left in the mouth during the entirety of the breath test sampling could contribute to the results in the breath testing sequence.~~ (3-23-22)

~~e.~~ ~~A complete breath alcohol test includes two (2) valid breath samples taken from the subject and preceded by an air blank. The breath samples do not need to be consecutive samples from the same subject. The individual breath samples should be approximately two (2) minutes apart or more. A deficient or insufficient sample does not automatically invalidate a test sample. The operator should use a new mouthpiece for each individual.~~ (3-23-22)

~~f.d.~~ A third breath sample is required if the first two (2) results differ by more than 0.02 g/210L alcohol. In the event that all three (3) samples fall outside the 0.02 g/210L alcohol correlation, and testing indicates or the officer suspects mouth alcohol, they must administer a fifteen (15) minute monitoring period and then retest the subject. If mouth alcohol is not suspected or indicated by the test results, then the officer may retest the subject without administering a monitoring period. (3-23-22)

ge. The operator should ~~manually log test~~ **document** results and/or retain printouts for possible use in court. (3-23-22)()

hf. The instrument must not be in passive mode for ~~the testing of an evidentiary~~ subjects ~~for evidential purposes~~ **but should only be used for testing liquids for the presence of alcohol.** (3-23-22)()

ig. The passive mode ~~of testing using the Lifeloc FC20 or ASH~~ should be used for testing liquids ~~or containers of liquid~~ for the presence or absence of alcohol. (3-23-22)()

015. -- 999. (RESERVED)

**IDAPA 11 – IDAHO STATE POLICE
PEACE OFFICER STANDARDS AND TRAINING COUNCIL**

11.11.01 – RULES OF THE IDAHO PEACE OFFICER STANDARDS AND TRAINING COUNCIL

DOCKET NO. 11-1101-2401

NOTICE OF RULEMAKING – ADOPTION OF PENDING RULE

EFFECTIVE DATE: This rule has been adopted by the agency and is now pending review by the 2025 Idaho State Legislature and must be approved by concurrent resolution of the Legislature to go into effect, in accordance with Section 67-5224(2)(c), Idaho Code. Should the pending rule be approved, it will become final and effective on July 1, 2025, in the year of the First Regular Session of the Sixty-eighth Idaho Legislature, unless the concurrent resolution states a different effective date.

AUTHORITY: In compliance with Section 67-5224, Idaho Code, notice is hereby given that this agency has adopted a pending rule. The action is authorized pursuant to Section 19-5107, Idaho Code.

DESCRIPTIVE SUMMARY: The following is a concise explanatory statement of the reasons for adopting the pending rule and a statement of any change between the text of the proposed rule and the text of the pending rule with an explanation of the reasons for the change:

When the rule was changed in 2021, it included adding the additional language to Subsection 11.11.01.055.03 address illegally purchasing or illegally possessing marijuana as disqualifying conduct. As published, there were no commas added to provide the context and meaning as intended by the POST Council in making the change. The intent was to disqualify an applicant who has used, illegally purchased, or illegally possessed marijuana within one year of application. Without the commas the meaning is changed to only preclude using illegally purchased or illegally possessed marijuana. This is counter to the intent of the POST Council in adding the language to address illegally purchasing or illegally possessing marijuana, in addition to its use within a year of application. The addition of the two commas corrects this error.

There are no changes to the pending rule, and it is being adopted as originally proposed. The complete text of the proposed rule was published in the July 03, 2024, Idaho Administrative Bulletin, [Vol. 24-7, pages 74-76](#).

FEE SUMMARY: Pursuant to Section 67-5224(2)(d), Idaho Code, a pending fee rule shall not become final and effective unless affirmatively approved by concurrent resolution of the Legislature. The following is a description of the fee or charge imposed or increased in this rulemaking: N/A

FISCAL IMPACT: The following is a specific description, if applicable, of any negative fiscal impact on the state general fund greater than ten thousand dollars (\$10,000) during the fiscal year: N/A

ASSISTANCE ON TECHNICAL QUESTIONS: For assistance on technical questions concerning this pending rule, contact Director Brad Johnson, Idaho Peace Officer Standards and Training, (208) 884-7251, brad.johnson@post.idaho.gov.

DATED this 23rd day of August, 2024.

Colonel Bill Gardiner, Director
Idaho State Police
700 S Stratford Drive
Meridian ID 83642
(208) 884-7004

IDAPA 13 – IDAHO DEPARTMENT OF FISH AND GAME

13.01.02 – RULES GOVERNING MANDATORY EDUCATION, MENTORED HUNTING, AND SHOOTING RANGES

DOCKET NO. 13-0102-2401

NOTICE OF RULEMAKING – TEMPORARY AND PROPOSED RULE

EFFECTIVE DATE: The effective date of the temporary rule is January 1, 2025.

AUTHORITY: In compliance with Sections 67-5221(1) and 67-5226, Idaho Code, notice is hereby given that this agency has adopted a temporary rule. The action is authorized pursuant to Section(s) 36-103, 36-104, 36-401, 36,409, 36-412, and 36-1101 Idaho Code.

PUBLIC HEARING SCHEDULE: Public hearing(s) concerning this rulemaking will be scheduled if requested in writing by twenty-five (25) persons, a political subdivision, or an agency, not later than October 16, 2024.

The hearing site(s) will be accessible to persons with disabilities. Requests for accommodation must be made not later than five (5) days prior to the hearing, to the agency address below.

DESCRIPTIVE SUMMARY: The following is the required finding and concise statement of its supporting reasons for adopting a temporary rule and a nontechnical explanation of the substance and purpose of the proposed rulemaking:

Killing of grizzly bears as a result of misidentification by black bear hunters has involved a small number of bears in Idaho over the past 20 years, and grizzly bear populations have continued to increase and expand during that time. To reduce this limited source of human-caused mortality, the Department has conducted outreach, included bear identification in its general mandatory hunter education, and provided voluntary education measures on bear identification.

This rulemaking addresses a United States Fish and Wildlife Service (USFWS) recommendation to adopt a bear identification test (as between black bear and grizzly bear) to avoid take of grizzly bear by misidentification. The temporary rule is similar to mandatory education requirements in Washington and Montana, and Idaho's rule would recognize completion of education in those states as meeting education requirements in Idaho.

TEMPORARY RULE JUSTIFICATION: Pursuant to Section(s) 67-5226(1) (a) and (c), Idaho Code, the Governor has found that temporary adoption of the rule is appropriate for the following reasons:

This temporary rule protects public safety and welfare by promoting proper identification of grizzly and black bears during hunting activities and by aligning with the recommendation of the USFWS in a timely manner, avoiding imposition of additional regulatory burden under the Endangered Species Act, and supporting reduction in federal regulatory burden under the Endangered Species Act by providing additional state regulatory mechanisms to achieve removal of grizzly bears from the federal list of endangered and threatened wildlife.

FEE SUMMARY: There is no fee associated with the change brought by this rulemaking.

FISCAL IMPACT: The following is a specific description, if applicable, of any negative fiscal impact on the state General Fund greater than ten thousand dollars (\$10,000) during the fiscal year: There is no fiscal impact associated with this rulemaking.

NEGOTIATED RULEMAKING: Pursuant to Section 67-5220(2), Idaho Code, negotiated rulemaking was not conducted because of the need to promptly address the USFWS recommendation for mandatory bear identification.

INCORPORATION BY REFERENCE: This rulemaking contains no incorporation by reference.

ASSISTANCE ON TECHNICAL QUESTIONS, SUBMISSION OF WRITTEN COMMENTS: For assistance on technical questions concerning the temporary and proposed rule, contact Amber Worthington (208) 334-3771.

Anyone may submit written comments regarding the proposed rulemaking. All written comments must be directed to the undersigned and must be delivered on or before October 23, 2024.

DATED this 21st day of August, 2024.

Amber Worthington
Deputy Director
Idaho Department of Fish and Game
600 S. Walnut Street
P.O. Box 25
Boise, ID 83707
(208) 334-3771

**THE FOLLOWING IS THE TEMPORARY RULE AND THE PROPOSED TEXT
OF DOCKET NO. 13-0102-2401
(Only Those Sections With Amendments Are Shown.)**

**13.01.02 – RULES GOVERNING MANDATORY EDUCATION,
MENTORED HUNTING, AND SHOOTING RANGES**

221. BEAR IDENTIFICATION.

No person may hunt black bear unless they have completed an online bear identification test (as between grizzly bear and black bear) administered by the Department of other state wildlife management agency with a passing score, as proven by printed certification. One may take a test repeatedly to pass. (1-1-25)T

224.2. – 249. (RESERVED)

IDAPA 13 – IDAHO DEPARTMENT OF FISH AND GAME

13.01.07 – RULES GOVERNING TAKING OF WILDLIFE

DOCKET NO. 13-0107-2401

NOTICE OF RULEMAKING – PROPOSED RULE

AUTHORITY: In compliance with Section 67-5221(1), Idaho Code, notice is hereby given that this agency has initiated proposed rulemaking procedures. The action is authorized pursuant to Sections 36-103, 36-104, 36-504, and 36-1101, Idaho Code.

PUBLIC HEARING SCHEDULE: Public hearing(s) concerning this rulemaking will be scheduled if requested in writing by twenty-five (25) persons, a political subdivision, or an agency, not later than October 16, 2024.

The hearing site(s) will be accessible to persons with disabilities. Requests for accommodation must be made not later than five (5) days prior to the hearing, to the agency address below.

DESCRIPTIVE SUMMARY: The following is a nontechnical explanation of the substance and purpose of the proposed rulemaking:

This rulemaking addresses two items. First, this rulemaking modifies four game management zones to align with changes in elk zones presented in the Department's Idaho Elk Management Plan 2024-2030. Zone changes comprise the following: Owyhee (remove GMU 38), Boise River (add GMU 38), Big Desert (add GMUs 53 and 68A), and Snake River (remove GMUs 53 and 68A).

Second, this rulemaking adds language to clarify that Department and Commission regulatory actions do not authorize any person to violate federal laws relative to federally protected wildlife when there is not a valid federal take authorization under federal law, regulation, or permit.

FEE SUMMARY: There is no fee associated with this rule.

FISCAL IMPACT: The following is a specific description, if applicable, of any negative fiscal impact on the state General Fund greater than ten thousand dollars (\$10,000) during the fiscal year resulting from this rulemaking: There is no fiscal impact associated with this rulemaking.

NEGOTIATED RULEMAKING: Pursuant to Section 67-5220(2), Idaho Code, negotiated rulemaking was not conducted for proposed rule IDAPA 13.01.07.250. This proposed rule is consistent with the 2024-2030 Idaho Elk Management Plan, which the Commission adopted in July 2024 after holding open houses in the seven Fish and Game Regions, public meetings of the Commission, draft plan issuance, and public comment opportunities.

Pursuant to Section 67-5220(2), negotiated rulemaking was not conducted for proposed Rule IDAPA 13.01.07.900 due to the simple nature of the rulemaking. The rulemaking clarifies that Department or Commission authorization of an activity does not authorize any person to violate federal law when there is not valid federal take authorization in place.

INCORPORATION BY REFERENCE: This rulemaking contains no incorporation by reference.

ASSISTANCE ON TECHNICAL QUESTIONS, SUBMISSION OF WRITTEN COMMENTS: For assistance on technical questions concerning the proposed rule, contact Amber Worthington, Deputy Director 208-334-3771.

Anyone may submit written comments regarding this proposed rulemaking. All written comments must be directed to the undersigned and must be delivered on or before October 23, 2024.

DATED this 21st day of August, 2024.

Amber Worthington
Deputy Director
Idaho Department of Fish and Game
600 S. Walnut Street
P.O. Box 25
Boise, ID 83707
(208) 334-3771

THE FOLLOWING IS THE PROPOSED TEXT OF DOCKET NO. 13-0107-2401
(Only Those Sections With Amendments Are Shown.)

13.01.07 – RULES GOVERNING TAKING OF WILDLIFE

250. GAME MANAGEMENT ZONE DESCRIPTIONS.

- | | | |
|------------|---|--------------------------|
| 01. | Panhandle Zone. All of Units 1, 2, 3, 4, 4A, 5, 6, 7, and 9. | (3-31-22) |
| 02. | Palouse Zone. All of Units 8, 8A, and 11A. | (3-31-22) |
| 03. | Dworshak Zone. All of Unit 10A. | (3-31-22) |
| 04. | Hells Canyon Zone. All of Units 11, 13, and 18. | (3-31-22) |
| 05. | Lolo Zone. All of Units 10 and 12. | (3-31-22) |
| 06. | Elk City Zone. All of Units 14, 15, and 16. | (3-31-22) |
| 07. | Selway Zone. All of Units 16A, 17, 19, and 20. | (3-31-22) |
| 08. | Middle Fork Zone. All of Units 20A, 26, and 27. | (3-31-22) |
| 09. | Salmon Zone. All of Units 21, 21A, 28, and 36B. | (3-31-22) |
| 10. | Weiser River Zone. All of Units 22, 32, and 32A. | (3-31-22) |
| 11. | McCall Zone. All of Units 19A, 23, 24, and 25. | (3-31-22) |
| 12. | Lemhi Zone. All of Units 29, 37, 37A, and 51. | (3-31-22) |
| 13. | Beaverhead Zone. All of Units 30, 30A, 58, 59, and 59A. | (3-31-22) |
| 14. | Brownlee Zone. All of Unit 31. | (3-31-22) |
| 15. | Sawtooth Zone. All of Units 33, 34, 35, and 36. | (3-31-22) |
| 16. | Pioneer Zone. All of Units 36A, 49, and 50. | (3-31-22) |
| 17. | Owyhee Zone. All of Units 38 , 40, 41, and 42. | (3-31-22) () |

- 18. **South Hills Zone.** All of Units 46, 47, 54, 55, 56, and 57. (3-31-22)
- 19. **Boise River Zone.** All of Units 38 and 39. (~~3-31-22~~)()
- 20. **Smoky - Bennett Zone.** All of Units 43, 44, 45, 48, and 52. (3-31-22)
- 21. **Big Desert Zone.** All of Units 52A, 53, 68, and 68A. (~~3-31-22~~)()
- 22. **Island Park Zone.** All of Units 60, 60A, 61, 62, and 62A. (3-31-22)
- 23. **Palisades Zone.** All of Units 64, 65, and 67. (3-31-22)
- 24. **Tex Creek Zone.** All of Units 66 and 69. (3-31-22)
- 25. **Bannock Zone.** All of Units 70, 71, 72, 73, 73A, and 74. (3-31-22)
- 26. **Bear River Zone.** All of Units 75, 77, and 78. (3-31-22)
- 27. **Diamond Creek Zone.** All of Units 66A and 76. (3-31-22)
- 28. **Snake River Zone.** All of Units ~~53,~~ 63, and 63A, ~~and 68A.~~ (~~3-31-22~~)()

(BREAK IN CONTINUITY OF SECTIONS)

501. – ~~98~~99. (RESERVED)

900. FEDERALLY PROTECTED WILDLIFE.

No authorization of an activity by the Commission or Department should be interpreted as state authorization to take federally protected wildlife in the absence of a federal take authorization, or as an exemption from prosecution for unauthorized take under federal or state law. In any instance where federal law prohibits taking of wildlife without federal authorization, authorization by the Commission or Department of an activity taking such federally protected wildlife is contingent upon that person also having valid federal take authorization. “Federal take authorization” includes authorization under federal law, regulation, permit, incidental take statement, or other valid federal authorization. “Authorization by the Commission or Department” includes authorization under Idaho law, administrative rule, proclamation, order, issuance of any license, or other state authorization. ()

901. – 999. (RESERVED)

IDAHA 13 – IDAHO DEPARTMENT OF FISH AND GAME

13.01.11 – RULES GOVERNING FISH

DOCKET NO. 13-0111-2401

NOTICE OF RULEMAKING – PROPOSED RULE

AUTHORITY: In compliance with Section 67-5221(1), Idaho Code, notice is hereby given that this agency has initiated proposed rulemaking procedures. The action is authorized pursuant to Sections 36-103, 36-104, 36-401, 36-406A, 36-407, 36-410, 36-701, 36-706, 36-901, 36-902, and 36-1001, Idaho Code.

PUBLIC HEARING SCHEDULE: Public hearing(s) concerning this rulemaking will be scheduled if requested in writing by twenty-five (25) persons, a political subdivision, or an agency, not later than October 16, 2024.

The hearing site(s) will be accessible to persons with disabilities. Requests for accommodation must be made not later than five (5) days prior to the hearing, to the agency address below.

DESCRIPTIVE SUMMARY: The following is a nontechnical explanation of the substance and purpose of the proposed rulemaking:

This rulemaking includes modifications of IDAPA 13.01.11.200.01.d and 13.01.11.220.04, Rules Governing Fish, Definitions and Fishing Methods and Gear sections that add a definition for “spearfishing,” expand opportunities for spearfishing to include take of certain game fish species and provide authority to the Commission through proclamation to determine seasons, fish species, and take limits for spearfishing.

FEE SUMMARY: There is no fee associated with this rule.

FISCAL IMPACT: The following is a specific description, if applicable, of any negative fiscal impact on the state General Fund greater than ten thousand dollars (\$10,000) during the fiscal year resulting from this rulemaking: There is no fiscal impact associated with this rulemaking.

NEGOTIATED RULEMAKING: Pursuant to Section 67-5220(1), Idaho Code, negotiated rulemaking was conducted. The Notice of Intent to Promulgate Rules - Negotiated Rulemaking was published in the July 3, 2024, Idaho Administrative Bulletin, [Volume 24-7](#), pages 78-79.

INCORPORATION BY REFERENCE: This rulemaking contains no incorporation by reference.

ASSISTANCE ON TECHNICAL QUESTIONS, SUBMISSION OF WRITTEN COMMENTS: For assistance on technical questions concerning the proposed rule, contact Amber Worthington, Deputy Director 208-334-3771.

Anyone may submit written comments regarding this proposed rulemaking. All written comments must be directed to the undersigned and must be delivered on or before October 23, 2024.

DATED this 23rd day of August, 2024.

Amber Worthington
Deputy Director
Idaho Department of Fish and Game
600 S. Walnut Street
P.O. Box 25
Boise, ID 83707
(208) 334-3771

THE FOLLOWING IS THE PROPOSED TEXT OF DOCKET NO. 13-0111-2401
(Only Those Sections With Amendments Are Shown.)

13.01.11 – RULES GOVERNING FISH

011. DEFINITIONS – CONDUCT OF FISHING.

- 01. Catch-and-Release.** Effort to catch fish, provided that any fish so caught is released immediately back to the water after landing and not reduced to possession. (7-1-24)
- 02. Commercial Fishing.** Fishing or transporting fish or crayfish for the purpose of selling. (7-1-24)
- 03. Fly Fishing.** Fishing with a fly rod, fly line, and artificial fly. (7-1-24)
- 04. Harvest.** Reduce a fish to possession. (7-1-24)
- 05. Ice Fishing.** Fishing through an opening broken or cut through the ice. (7-1-24)
- 06. Length.** The length between the tip of the nose or jaw and the tip of the tail fin. (7-1-24)
- 07. Snagging.** Taking fish by use of a hook or lure in any manner or method other than enticing or attracting a fish to strike with, and become hooked in, its mouth or jaw. (7-1-24)
- 08. Spearfishing.** Taking of fish by a person while underwater, with the aid of a manually or mechanically propelled single- or multiple-pronged spear. ()
- 089. Trollng.** Taking a fish from a moving watercraft by dragging or pushing any fly, lure, bait, or hook using a motor, oars, or other forms of propulsion. (7-1-24)
- 0910. Unattended Line.** Line not under the immediate surveillance by the angler. (7-1-24)

(BREAK IN CONTINUITY OF SECTIONS)

200. FISHING METHODS AND GEAR.

- 01. General Restrictions.** Unless modified by rule (such as exceptions in the following subsections), order, or proclamation, it is unlawful to: (7-1-24)
- a.** Fish in any waters of Idaho with more than one (1) handline or pole with a line attached, unless in possession of a valid two-pole permit. (7-1-24)
- b.** Leave an unattended line. (7-1-24)
- c.** Have more than five (5) hooks attached per line. (7-1-24)
- d.** Use more than five (5) lines while ice fishing. (7-1-24)
- e.** Fish by archery, spearfishing, snagging, hands, trapping, seining, or netting. (7-1-24)
- f.** Use live fish, leeches, frogs, salamanders, waterdogs, or shrimp as bait. (7-1-24)

- g.** Land any fish with a gaff hook. (7-1-24)
- h.** Molest any fish by shooting at it with a firearm or pellet gun, striking at it with a club, hands, rocks, or other objects, building obstructions for catching fish, or chasing fish up or downstream in any manner. (7-1-24)
- i.** Fish from a watercraft with a motor attached in waters listed in proclamation as “no motors.” (7-1-24)
- j.** Use gas (internal combustion) motors on fishing waters listed in proclamation as “electric motors only,” although it may be attached to the boat. (7-1-24)

02. Snagging, Archery, and Spear-Fishing Exceptions. ()

a. ~~The Unprotected fish may be taken by~~ use of snagging, bow and arrow, crossbow, spear or mechanical device, excluding firearms, ~~is permitted for the taking of unprotected fish,~~ provided there is an open season for game fish. (7-1-24)()

b. Game fish may be taken by spearfishing as authorized by Commission proclamation. ()

03. Gaff Hook Exceptions. The use of a gaff hook is permitted while ice fishing in waters which have no length restrictions or harvest closures for that species, or when landing unprotected fish species taken with archery equipment. (7-1-24)

04. Trapping and Seining Exceptions. It is lawful to take unprotected fish, crayfish, and yellow perch with a minnow net, seine, or up to five (5) traps, unless there is an open season for game fish, and provided the following conditions are met: (7-1-24)

- a.** The seine or net does not exceed ten (10) feet in length or width, and the seine has three-eighths (3/8) inch square or smaller mesh; and the minnow or crayfish trap does not exceed two (2) feet in length, width or height. If the trap is of irregular dimension, but its volume does not exceed the volume of an eight (8) cubic foot trap, it is lawful to use. (7-1-24)
- b.** Nets and seines are not left unattended. (7-1-24)
- c.** Traps are checked at least every forty-eight (48) hours. (7-1-24)
- d.** All game fish and protected nongame fish incidentally captured while trapping or seining are immediately released alive. (7-1-24)
- e.** All traps have a tag attached bearing the owner's name and address, license number, or sportsman identification number. (7-1-24)

05. Use of Bait Exceptions. Live crayfish and bullfrog may be used for bait if caught on the body of water being fished. (7-1-24)

06. Use of Hands Exceptions. Bullfrog and crayfish may be taken with the hands. (7-1-24)

07. Fishing Shelters. Any enclosure or shelter left unattended overnight on the ice of any waters of the state shall have the owner's name, telephone numbers, and current address, or sportsman identification number legibly marked on two (2) opposing sides of the enclosure or shelter. (7-1-24)

IDAPA 13 – IDAHO DEPARTMENT OF FISH AND GAME

13.01.17 – RULES GOVERNING USE OF BAIT FOR HUNTING BIG GAME ANIMALS

DOCKET NO. 13-0117-2402

NOTICE OF RULEMAKING – ADOPTION OF TEMPORARY RULE

EFFECTIVE DATE: The effective date of the temporary rule is September 1, 2024.

AUTHORITY: In compliance with Sections 67-5226, Idaho Code, notice is hereby given this agency has adopted a temporary rule. The action is authorized pursuant to Section(s) 36-104, 36-409, and 36-1101, Idaho Code.

DESCRIPTIVE SUMMARY: The following is the required finding and concise statement of its supporting reasons for adopting a temporary rule:

This rulemaking adds a new section requiring a person placing or using bait for hunting black bear to report the presence of a grizzly bear at the site to the Department and to remove the bait from that location. This rulemaking is for the purpose of preventing a person from unlawfully taking a grizzly bear and improving safety related to black bear hunting. This rulemaking addresses the use of bait in black bear hunting in areas outside of occupied grizzly bear recovery areas identified by the U.S. Fish and Wildlife Service (where the Commission has long prohibited the use of bait in black bear hunting). This rulemaking provides an additional state regulatory mechanism to further support removal of grizzly bears from the federal list of endangered and threatened wildlife and achieve reduction in federal regulatory burden. This rule is similar to a Wyoming regulation for use of bait in black bear hunting that has been in place for a number of years.

This rulemaking addresses the use of bait in black bear hunting in areas outside of occupied grizzly bear recovery areas identified by the U.S. Fish and Wildlife Service. (The Commission has long prohibited the use of bait in black bear hunting in occupied recovery areas in Game Management Unit 1 and Game Management Units in the Greater Yellowstone Recovery Area.)

Proposed rulemaking is being conducted under Docket No. 13-0108-2401, (Zero-Based Regulation (ZBR) Rulemaking), previously published in Bulletin Vol. 24-5 p.190, and Docket No. 13-0117-2401 (ZBR Rulemaking) as previously published in Bulletin Vol. 24-5 p.194.

TEMPORARY RULE JUSTIFICATION: Pursuant to Section(s) 67-5226(1)(a) and (c), Idaho Code, the Governor has found that temporary adoption of the rule is appropriate for the following reasons:

This temporary rule adoption protects public safety and welfare by preventing a person from unlawfully taking a grizzly bear during black bear hunting and improving safety of black bear hunting with use of bait. As described above, this rulemaking provides an additional state regulatory mechanism to further support removal of grizzly bears from the federal list of endangered and threatened wildlife and achieve reduction in federal regulatory burden.

FEE SUMMARY: There is no fee associated with the change brought by this rulemaking.

ASSISTANCE ON TECHNICAL QUESTIONS: For assistance on technical questions concerning the temporary rule, contact Amber Worthington (208) 334-3771.

DATED this 21st day of August, 2024.

Amber Worthington
Deputy Director
Idaho Department of Fish and Game
600 S. Walnut Street
P.O. Box 25
Boise, ID 83707
(208) 334-3771

THE FOLLOWING IS THE TEXT OF THE TEMPORARY RULE FOR DOCKET NO. 13-0117-2402
(Only Those Sections With Amendments Are Shown.)

13.01.17 – RULES GOVERNING USE OF BAIT FOR HUNTING BIG GAME ANIMALS

201. -- ~~92~~99. (RESERVED)

300. USE OF BAIT BY A GRIZZLY BEAR.

Any person placing bait to hunt black bear, hunting at a bait site, or witnessing the use of a bait site by a grizzly bear must immediately report use of the bait by a grizzly bear to the Department. No person may hunt black bear over such a bait site for the remainder of the current black bear hunting season. The bait site(s) will be closed for the remainder of the current black bear hunting season and the bait must be removed as soon as possible. (9-1-24)T

301. -- 999. (RESERVED)

IDAPA 16 – DEPARTMENT OF HEALTH AND WELFARE

16.02.13 – STATE OF IDAHO DRINKING WATER LABORATORY CERTIFICATION PROGRAM

DOCKET NO. 16-0213-2401 (ZBR CHAPTER REWRITE, FEE RULE)

NOTICE OF PUBLIC HEARING AND EXTENSION OF WRITTEN COMMENT PERIOD

AUTHORITY: In compliance with Section 67-5221(1), Idaho Code, notice is hereby given that this agency has initiated proposed rulemaking procedures. The action is authorized pursuant to Section 56-202, Idaho Code, and Sections 56-1003 and 56-1007, Idaho Code.

PUBLIC HEARING SCHEDULE: A public hearing concerning this rulemaking will be held as follows:

<p>VIRTUAL TELECONFERENCE Via WebEx</p>
<p>Wednesday, October 16, 2024 9:00 a.m. to 10:00 a.m. (MT)</p>
<p>Join from the meeting link: https://idhw.webex.com/idhw/j.php?MTID=m6d61af5defe2ca0dd4dc6c8bd863208a</p> <p>Join by meeting number: Meeting number (access code): 2822 958 5990 Meeting password: JhFdJtt5d42 (54335885 when dialing from a phone or video system)</p> <p>Join by phone: +1-415-527-5035 United States Toll +1-303-498-7536 United States Toll (Denver)</p>

The hearing site(s) will be accessible to persons with disabilities. Requests for accommodation must be made not later than five (5) days prior to the hearing, to the agency address below.

DESCRIPTIVE SUMMARY: The summary of this action is found in the September 4th, 2024, Idaho Administrative Bulletin Vol. 24-9, pages 132-133.

ASSISTANCE ON TECHNICAL QUESTIONS: For assistance on technical questions concerning this rulemaking, contact Jared Larsen at 208-334-5500.

SUBMISSION OF WRITTEN COMMENTS: The comment period for this rulemaking has been extended. Anyone may submit written comments regarding this rulemaking during this comment period or a written comment may be submitted at the public hearing in lieu of giving an oral presentation. Any written comments submitted at a public hearing carry the same weight as oral testimony and will be considered as such.

All written comments must be directed to the undersigned and must be delivered on or before October 16th, 2024.

DATED this 13th day of September, 2024.

Alex J. Adams, PharmD, MPH
Director
Idaho Department of Health & Welfare
450 W. State Street, 10th Floor
P.O. Box 83720
Boise, ID 83720-0036
(208) 334-5500 phone; (208) 334-6558 fax
Alex.Adams@dhw.idaho.gov

IDAPA 17 – INDUSTRIAL COMMISSION

17.01.01 – ADMINISTRATIVE RULES UNDER THE WORKER'S COMPENSATION LAW

DOCKET NO. 17-0101-2301 (ZBR CHAPTER REWRITE)

NOTICE OF RULEMAKING – PROPOSED RULE

AUTHORITY: In compliance with Section 67-5221(1), Idaho Code, notice is hereby given that this agency has initiated proposed rulemaking procedures. The action is authorized pursuant to Sections 72-508 and 72-304, Idaho Code.

PUBLIC HEARING SCHEDULE: Public hearings concerning this rulemaking will be held as follows:

17.01.01 – Administrative Rules Under The Worker’s Compensation Law
Monday, October 7, 2024 – 10:00 a.m. - 11:00 a.m. (MT) Sawtooth Room, Chinden Campus Building 2 11321 W. Chinden Blvd. Boise, ID 83714
Virtual Meeting Link

17.01.01 – Administrative Rules Under The Worker’s Compensation Law
Thursday, October 24, 2024 – 10:00 a.m. - 11:00 a.m. (MT) Sawtooth Room, Chinden Campus Building 2 11321 W. Chinden Blvd. Boise, ID 83714
Virtual Meeting Link

The hearing site(s) will be accessible to persons with disabilities. Requests for accommodation must be made not later than five (5) days prior to the hearing, to the agency address below.

DESCRIPTIVE SUMMARY: The following is a nontechnical explanation of the substance and purpose of the proposed rulemaking:

Under [Executive Order 2020-01, Zero-Based Regulation](#), the Industrial Commission is striving to prevent the accumulation of costly, ineffective, and outdated regulations and reduce regulatory burden to achieve a more efficient operation of government. In conjunction with stakeholders, the proposed rule changes reflect a comprehensive review of this chapter by collaborating with the public to streamline or simplify the rule language in this chapter and to use plain language for better understanding. This proposed rulemaking updates the rules to comply with governing statute and Executive Order 2020-01.

FEE SUMMARY: The following is a specific description of the fee or charge imposed or increased: The proposed amendments to the rules don’t impose any new or increased fees.

FISCAL IMPACT: The following is a specific description, if applicable, of any negative fiscal impact on the state General Fund greater than ten thousand dollars (\$10,000) during the fiscal year as a result of this rulemaking: There is no anticipated fiscal impact.

NEGOTIATED RULEMAKING: Pursuant to Section 67-5220(1), Idaho Code, negotiated rulemaking was conducted. The Notice of Intent to Promulgate Rules - Negotiated Rulemaking was published in the November 1, 2024 Idaho Administrative Bulletin, Vol. 23-11, pg. 18-19 and the May 1, 2024 Idaho Administrative Bulletin, Vol.24-5, pg. 206-210.

INCORPORATION BY REFERENCE: Pursuant to Section 67-5229(2)(a), Idaho Code, the following is a brief synopsis of why the materials cited are being incorporated by reference into this rule:

Incorporation of the CMS Fee Schedules (Physician Fee Schedule, Acute Inpatient Prospective Payment System, Hospital Outpatient Prospective Payment System, Ambulatory Surgical Center Payment System) and the CPT Codes are necessary because, pursuant to Idaho Code 72-803, the Commission is required to use these schedules to set fees for physician services for medical services and for medicine and related benefits. Additionally, it is critical to use a universally recognized standard so both payors and providers are aware of how costs for medical services, medicine and related benefits will be reimbursed. Incorporation of the EDI Implementations Guides is necessary because it is an industry practice to use a universally recognized standard for claim data and reporting.

ASSISTANCE ON TECHNICAL QUESTIONS, SUBMISSION OF WRITTEN COMMENTS: For assistance on technical questions concerning the proposed rule, contact Kamerron Slay, Commission Secretary, (208) 334- 6017 or Kamerron.slay@iic.idaho.gov.

Anyone may submit written comments regarding this proposed rulemaking. All written comments must be directed to the undersigned and must be delivered on or before October 28, 2024.

DATED this 28th day of August, 2024.

George Gutierrez, Director
Industrial Commission
11321 W. Chinden Blvd.
P.O. Box 83720
Boise, Idaho 83720-0041
Phone: 208-334-6000
Fax: 208-334-2321

THE FOLLOWING IS THE PROPOSED TEXT OF DOCKET NO. 17-0101-2301
(ZBR Chapter Rewrite)

17.01.01 – ADMINISTRATIVE RULES UNDER THE WORKER'S COMPENSATION LAW

000. LEGAL AUTHORITY.

~~This chapter is adopted under the legal authority of 72-301, 72-301A, 72-304, 72-327, 72-432, 72-508, 72-528, 72-602, 72-803, and 72-806, Idaho Code.~~ (3-23-22)()

001. TITLE AND SCOPE.

01. Title. The title of this chapter is “Administrative Rules Under the Worker's Compensation Law” ~~IDAPA 17, Title 01, Chapter 01.~~ (3-23-22)

02. Scope. This chapter includes the Industrial Commission's worker's compensation rules. (3-23-22)

001. (RESERVED)

002. WRITTEN INTERPRETATIONS INCORPORATION BY REFERENCE.

The Industrial Commission uses the following guidelines for implementing the EDI reporting requirements set out in this Chapter. These rules incorporate by reference the following documents, which may be obtained from the main office of the Industrial Commission or are available on the agency's website. (3-23-22)()

01. EDI Guide and Tables. The Idaho Industrial Commission Claims EDI Implementation Guide and Trading Partner Tables ("EDI Guide and Tables"). The Idaho Industrial Commission Claims EDI Implementation Guide and Trading Partner Tables are available on the Commission's website at <https://iic.idaho.gov/>. (3-23-22)

02. EDI Implementation Guide. International Association of Industrial Accidents Boards and Commissions (IAIABC) EDI Claims Release 3.0 or, after September 14, 2023, Release 3.1, Implementation Guide ("EDI Implementation Guide"). The IAIABC Claims Release 3.0 and Release 3.1 Implementation Guides are available at the IAIABC website at <https://www.iaiaabc.org>. (4-6-23)

01. EDI Implementation Guide. The Industrial Commission uses the International Association of Industrial Accident Boards and Commissions (IAIABC) Electronic Data Interchange (EDI) Claims Implementation Guide ("EDI Implementation Guide"), as published annually, available at <http://www.iaiaabc.org/edi-claims>, and the IAIABC Claims EDI Implementation Guide and Trading Partner Tables available at <https://iic.idaho.gov/>. See Rule 601 of these rules. ()

02. CMS Fee Schedules. Pursuant to Idaho Code § 72-803, these rules incorporate by reference the Physician Fee Schedule, Hospital Outpatient Prospective Payment System, and Ambulatory Surgical Center Payment System, as published by the Centers for Medicare and Medicaid Services (CMS), effective January 1, 2024, available at <https://www.cms.gov/medicare/payment/fee-schedules/physician>; <https://www.cms.gov/medicare/payment/prospective-payment-systems/hospital-outpatient>; <https://www.cms.gov/medicare/payment/prospective-payment-systems/ambulatory-surgical-center-asc> respectively. Additionally, these rules incorporate by reference the Acute Inpatient Prospective Payment System, as published by the CMS, effective October 1, 2024, available at <https://www.cms.gov/medicare/payment/prospective-payment-systems/acute-inpatient-pps>. See Rule 803 of these rules. ()

03. CPT Codes. Pursuant to Idaho Code § 72-803, these rules incorporate by reference the Current Procedural Terminology (CPT) codes, as published by the American Medical Association, effective January 1, 2024, available at ama-assn.org/practice-management/cpt. See Rule 803 of these rules. ()

003 – 009. (RESERVED)

010. DEFINITIONS.

The definitions set forth in Chapter 72, Idaho Code apply to these rules. In addition, the following terms have the meaning set forth below: (3-23-22)

01. Adjustor. Means an individual who adjusts worker's compensation claims. (3-23-22)

02. Ambulatory Payment Classification (APC). Means the payment system adopted by Centers for Medicare and Medicaid Services (CMS) for outpatient services (3-23-22)()

03. Available Funds. Means a sum of money to which a Charging Lien may attach. It does not include any compensation paid or not disputed to be owed prior to Claimant's agreement to retain the attorney. (3-23-22)

04. Ambulatory Surgery Center (ASC). Means a facility providing medical services on an outpatient basis only. (3-23-22)()

05. Approval by Commission. Means the Commission has approved attorney fees in conjunction with an award of compensation or an Settlement Agreement (SA) ~~LSS~~ or otherwise in accordance with Section 802 of this rule upon a proper showing by the attorney seeking to have the fees approved. (3-23-22)()

06. Average Wholesale Price (AWP). Means the average wholesale price for medicine obtained from pricing data provided by the original manufacturer of that medicine to industry-wide compilers of drug prices, e.g., Red Book and Medi-Span. (3-23-22)()

07. Charge. Means the expense or cost. For hospitals and ASCs, “charge” means the total charge. (3-23-22)

a. Acceptable charge. Means a charge calculated in compliance with Section 803 of this rule or as billed by the Provider, whichever is lower, or the charge agreed to pursuant to a written contract. (3-23-22)

b. Customary charge. Means a charge that has an upper limit no higher than the 90th percentile, as determined by the Commission, of usual charges made by Idaho Providers for a given medical service. (3-23-22)

c. Reasonable charge. Means a charge that does not exceed the Provider's “usual” charge and does not exceed the “customary” charge. (3-23-22)

d. Usual charge. Means the most frequent charge made by an individual Provider for a given medical service to non-industrially injured patients. (3-23-22)

08. Charging Lien. Means a lien against a Claimant's right to any compensation under the Worker's Compensation Law, which may be asserted by an attorney who is able to demonstrate that: (3-23-22)

a. There are compensation benefits available for distribution on equitable principles; (3-23-22)

b. The services of the attorney operated primarily or substantially to secure the fund out of which the attorney seeks to be paid; (3-23-22)

c. It was agreed that counsel anticipated payment from compensation funds rather than from the client; (3-23-22)

d. The Claim is limited to costs, fees, or other disbursements incurred in the case through which the fund was raised; and (3-23-22)

e. There are equitable considerations that necessitate the recognition and application of the Charging Lien. (3-23-22)

09. Claim. Means filing for worker's compensation benefits through a Form 1A-1, First Report of Injury or Illness (FROI) or an application for hearing, referred to as a Complaint, with the Commission. (3-23-22)

10. Claims Administrator. Means an organization, including insurers, third party administrators, independent adjusters, or self-insured employers, that services worker's compensation claims. (3-23-22)

11. Claims Services. Aspects of claims handling to include but are not limited to reserve setting, three-point contacts, accident investigations, acceptance or denial of claims, authorization of medical treatment, authorization and triggering of the medical and income benefit payments to be issued. Medical fee schedule adjustments and issuance of authorized benefit payments may be considered ministerial or administrative functions. ()

11. Claimant. Means a person who has filed a Claim for worker's compensation benefits and includes their agents, such as attorneys. (3-23-22)

~~**12. Commission.** Means the Idaho Industrial Commission.~~ (3-23-22)

13. Critical Access Hospital. Means a hospital currently designated as a critical access hospital by CMS. (3-23-22)

14. Current Procedural Terminology (CPT). Means the medical code published by the American

Medical Association. (3-23-22)()

15. Death Claim. Means a Claim arising from the death of a worker as a result of a work-related injury or occupational disease. (3-23-22)

16. Electronic Data Interchange (EDI). Means a computer to computer exchange of data in a standardized format. (3-23-22)()

17. Fee Agreement. Means a written agreement between a worker and an attorney in conformity with the Idaho Rules of Professional Conduct. (3-23-22)

a. Reasonable, as used in Section 802 of this rule, means that an attorney's fees are consistent with the fee agreement and are to be satisfied from Available Funds, subject to the element of reasonableness contained in Idaho Rules of Professional Conduct 1.5. (3-23-22)

18. First Degree of Consanguinity. Means the relationship between parents and their children whether related by blood or affinity. Adopted or step children and their adoptive or step parents are deemed to be within the first degree of consanguinity. (3-23-22)

19. First Report of Injury (FROI). Means the first filing of information with the Industrial Commission that a reportable workplace injury has occurred or an occupational disease has ~~been~~ manifested, as required by Section 72-602(1), Idaho Code; filed in accordance with these rules. (3-23-22)()

20. Gross Direct Premiums Written. Means the gross sum of premiums on policies written, without any deduction for refunds or repayments resulting from cancellations. It does not include premiums on contracts between insurers or reinsurers. For all policies written, gross direct premiums written may reflect experience modifications, deviations, and retrospective rating. (3-23-22)

21. Healthcare Common Procedure Coding System (HCPCS). Means the set of healthcare procedure codes based on the American Medical Association's Current Procedural Terminology. (3-23-22)()

22. Hospital. Means an acute care facility providing medical or rehabilitation services on an inpatient and outpatient basis. (3-23-22)

23. IAIABC EDI ~~Release 3.0 or 3.1~~ Claims. Means the IAIABC authored EDI Claims ~~Release 3.0 or 3.1~~ standards that cover the transmission of claims (FROI and SROI) information ~~through electronic reporting.~~ (3-23-22)()

24. Impairment Rated Claim. Means those claims in which the Provider establishes an impairment rating for the ~~injured worker~~ claimant or the claimant has a statutory impairment award per the schedule. (3-23-22)()

25. Implantable Hardware. Means objects or devices that are made to support, replace, or act as a missing anatomical structure or to support or manage proper biological functions or disease processes and where surgical or medical procedures are needed to insert or apply such devices and surgical or medical procedures are required to remove such devices. The term also includes equipment necessary for the proper operation of the implantable hardware, even if not implanted in the body. (3-23-22)

26. Indemnity Benefits. Means payments made to or on behalf of worker's compensation Claimants, including temporary or permanent total or partial disability benefits, death benefits paid to dependents, retraining benefits, and any other type of income benefits, but excluding medical and related benefits. (3-23-22)

27. Indemnity Claim. Means any claim made for the payment of indemnity benefits. (3-23-22)

~~28. Legacy Claim.~~ ~~Means a FROI that was either filed on paper or electronically prior to the EDI Claims Release 3.1 implementation.~~ (3-23-22)

- ~~298.~~ **Litigated Case.** Means a case in which a complaint has been filed. (3-23-22)
- ~~3029.~~ **Medical Only Claim.** Means the ~~injured worker~~ claimant will not suffer a disability lasting more than five (5) calendar days as a result of a job-related injury or occupational disease, nor be admitted to a hospital as an inpatient. (~~3-23-22~~)()
- ~~3130.~~ **Medical Report.** Means and includes without limitation, all bills, chart notes, surgical records, testing results, treatment records, hospital records, prescriptions, and medication records. (3-23-22)
- ~~321.~~ **Medicare Severity - Diagnosis Related Group.** Means a system adopted by CMS that groups hospital admissions based on diagnosis codes, surgical procedures, and patient demographics. (3-23-22)
- ~~332.~~ **Net Premiums Written.** Means the amount of gross direct premiums on policies written less returned premiums and premiums on policies not taken. Paid dividends shall not be deducted for the purposes of calculating net premiums written. (3-23-22)
- ~~343.~~ **Payor.** Means the entity that is responsible for making payment to a Provider for services rendered to treat an ~~an industrially injured patient~~ claimant and includes self-insured employers, sureties, adjusters, and their agents. (~~3-23-22~~)()
- ~~354.~~ **Payroll.** Means the gross amount paid by an employer for salaries, wages, or commissions earned by its own direct employees, but not including any money paid to another entity or received from another entity for leased employees. (3-23-22)
- ~~365.~~ **Pharmacy.** Means a facility as defined in Section 54-1705(29), Idaho Code. (3-23-22)
- ~~376.~~ **Supplemental or Subsequent Report of Injury (SROI).** Means the filing of additional information with the Industrial Commission, regarding benefits paid or changes in the status or condition of an ~~injured worker~~ claimant, of a Claim for benefits, as required by Sections 72-602(2), (3), and (4), Idaho Code; filed in accordance with these rules. (~~3-23-22~~)()
- ~~387.~~ **Termination of Disability.** Means the date upon which the obligation of the Employer/Surety becomes certain as to duration and amount whether by settlement agreement (SA), decision, or periodic payments in the ordinary course of claims processing. If resolved by ~~LSS SA~~, the termination of disability shall occur on the date the ~~LSS SA is approved and~~ filed or an order approving is filed by the Industrial Commission. If resolved by decision, the termination of disability shall occur on the date the decision resolving all issues becomes final. (~~3-23-22~~)()
- ~~398.~~ **Time Loss Claim.** Means the ~~injured worker~~ claimant will suffer, or has suffered, a disability that lasts more than five (5) calendar days as a result of a job-related injury or occupational disease, or the ~~injured worker~~ claimant requires, or required, in-patient treatment as a result of such injury or disease. (~~3-23-22~~)()
- ~~4039.~~ **Trading Partner.** Means an insurance carrier, self-insured employer, or Claims Administrator that has entered into a Trading Partner Agreement with the Industrial Commission. (3-23-22)
- ~~410.~~ **Trading Partner Agreement.** Means an agreement between the Industrial Commission and a Trading Partner that sets out the terms and conditions for the electronic reporting of information to the Commission. (3-23-22)
- ~~011.~~ **ABBREVIATIONS.**
The following abbreviations have the meaning set forth below: (~~3-23-22~~)
- ~~01.~~ **APC.** Means Ambulatory Payment Classification. (~~3-23-22~~)
- ~~02.~~ **ASC.** Means Ambulatory Surgery Center. (~~3-23-22~~)
- ~~03.~~ **AWP.** Means Average Wholesale Price. (~~3-23-22~~)

- ~~04. CMS. Means Centers for Medicare and Medicaid Services. (3-23-22)~~
- ~~05. CPT. Means Current Procedural Terminology. (3-23-22)~~
- ~~06. EDI. Means Electronic Data Interchange. (3-23-22)~~
- ~~07. FROI. Means First Report of Injury. (3-23-22)~~
- ~~08. HCPCS. Means Healthcare Common Procedure Coding System. (3-23-22)~~
- ~~09. IAABC. Means International Association of Industrial Accident Boards and Commissions. (3-23-22)~~
- ~~10. ISIF. Means the Industrial Special Indemnity Fund, which is commonly referred to as the Second Injury Fund. (3-23-22)~~
- ~~11. LSS. Means Lumps Sum Settlement. (3-23-22)~~
- ~~12. MSDRG. Means Medicare Severity Diagnosis Related Group. (3-23-22)~~
- ~~13. NCCI. Means National Council on Compensation Insurance. (3-23-22)~~
- ~~14. NDC. Means National Drug Code. (3-23-22)~~
- ~~15. RBRVS. Means Resource Based Relative Value Scale. (3-23-22)~~
- ~~16. RVU. Means Relative Value Unit. (3-23-22)~~
- ~~17. SROI. Means Supplemental or Subsequent Report of Injury. (3-23-22)~~

~~012. LIBERAL CONSTRUCTION.~~

~~Rulemaking before the Industrial Commission should be just, speedy, and economical; unless prohibited by statute, the Industrial Commission may permit deviation from these rules when it finds compliance with them is impracticable, unnecessary, or not in the public interest. (3-23-22)~~

~~013~~1. -- 200. (RESERVED)

201. RULE GOVERNING 72-212(5) EXEMPTIONS.

01. Exemptions. Each person who elects to exempt themselves from coverage or revoke their exemption under Section 72-212(5), Idaho Code, must file an IC53 Declaration form with the Industrial Commission. The form is available on the Commission's website. (3-23-22)

02. Form. The form must be signed by both the employee and the employer. An original and one (1) copy of the IC53 form shall be filed with the Commission. Upon approval by the Commission, the copy will be returned to the employee filing for an exemption or revocation of an exemption. (3-23-22)

03. Approval by Commission. The Commission must approve the exemption or revocation of exemption. The Commission may require verification of information submitted. Fraud or misrepresentation in the information provided will void the exemption or revocation. (3-23-22)

04. IC53 Form. If the employer is insured, it is the employer's responsibility to file a copy of the IC53 form with the employer's insurance company. (3-23-22)

~~05. Effective Date. The effective date of the exemption or revocation of exemption shall be the date the properly completed form is received by the Commission. (3-23-22)~~

~~06. Exemption Effective. The exemption shall remain in effect until a revocation of exemption is filed with the Commission, or, termination of employment with the designated employer, or upon the death of the employee, whichever occurs first.~~ (3-23-22)

202. -- 300. (RESERVED)

301. RULES GOVERNING QUALIFICATIONS TO WRITE INSURANCE OR SELF-INSURE.

01. Insurance Carriers. In order to gain approval from the Industrial Commission to underwrite worker's compensation insurance under Section 72-301, Idaho Code, an insurance carrier shall comply with the additional following requirements: (3-23-22)()

a. Deposit With State Treasurer. The carrier must receive approval from the Director of the Idaho Department of Insurance to underwrite casualty and surety insurance under Sections 41-506 and 41-507, Idaho Code, and shall initially deposit security in the amount of two hundred fifty thousand dollars (\$250,000) with the State Treasurer, under the provisions of Section 72-302, Idaho Code. (3-23-22)

b. Application. To receive approval from the Industrial Commission, an insurance carrier must ~~supply an application with~~ submit a completed application, available from the Industrial Commission's Fiscal Department, including: (3-23-22)()

i. ~~A statement recommendation from the Director of the Idaho Department of Insurance documenting compliance with Paragraph 01.a, above that the carrier be approved to transact worker's compensation insurance in the State of Idaho;~~ (3-23-22)()

ii. The latest audited financial statement of said carrier; (3-23-22)

iii. ~~The name and address of the agent for service of process in Idaho~~ A statement appointing the Director of the State of Idaho Department of Insurance as its agent to receive service of legal process; (3-23-22)()

iv. The name and address of the carrier's appointed Claims Administrator employing an Idaho licensed resident adjuster or the insurance carrier's own in-house Idaho adjusting staff with authority to make compensation payments and adjustments of claims arising under the Act. Each Claims Administrator shall have only one (1) mailing address on record at the Commission for claims adjusting purposes. If more than one (1) Claims Administrator is utilized in Idaho, a list of every such Claims Administrator and all corresponding policyholders shall be provided; (3-23-22)()

v. A statement that the carrier will distribute blank forms that are prescribed by the Commission to its insured; (3-23-22)

vi. A statement that all surety bonds covering the payment of compensation will be filed with the Idaho State Treasurer for all employers insured. All carriers will use the continuous bond form set out on the Commission's website. (3-23-22)

vii. A statement that renewal certificates on said bonds will be issued and filed with the Industrial Commission immediately, when and if renewed; (3-23-22)

viii. A statement that all surety contract cancellations will be canceled in compliance with Section 72-311, Idaho Code; (3-23-22)

ix. A statement that said carrier will deposit, in addition to other security required by this rule, further security equal to all unpaid outstanding awards of compensation; (3-23-22)

x. A statement that said carrier will comply with the statutes of the state of Idaho and rules of the Industrial Commission and that payments of compensation shall be sure and certain and not unnecessarily delayed;

and (3-23-22)

xi. A statement that the carrier will make reports to the Commission as are required. (3-23-22)

xii. ~~A copy of the Certificate of Authority from the carrier's State of Domicile.~~ ()

02. Self-Insured Employers. In order to gain written approval from the Industrial Commission to self-insure under Section 72-301, Idaho Code, an employer shall comply with the following requirements: (3-23-22)()

a. Payroll. Have an average annual Idaho Payroll over the preceding three (3) years of at least ~~four~~ seven million dollars (\$7,000,000). (3-23-22)()

b. Application. Submit a completed application, available from the Industrial Commission's Fiscal Department, along with the application fee of two hundred fifty dollars (\$250), to the Idaho Industrial Commission, Attention: Fiscal Department, including: (3-23-22)()

~~ei.~~ Documentation. ~~Submit documentation~~ demonstrating the sound financial condition of the employer, such as the most recent CPA reviewed or, if available, audited, financial statement. (3-23-22)()

~~dii.~~ ~~Claims Adjusting. Designate in writing~~ Written designation of a Claims Administrator employing an Idaho licensed resident adjuster including name and address. Each Claims Administrator shall have only one (1) mailing address on record at the Commission for claims adjusting purposes. (3-23-22)()

~~eiii.~~ ~~Previous Claims. Provide a~~ A claims history of all worker's compensation claims filed with the employer or the employer's worker's compensation carrier, as well as all compensation paid, during the previous five (5) calendar years. (3-23-22)()

~~fi.~~ ~~Excess Insurance. Provide a~~ A copy of an insurance plan that ~~must~~ includes excess insurance coverage ~~and or~~ copies of all proposed policies of excess worker's compensation insurance coverage. (3-23-22)()

~~g.~~ ~~Actuarial Study. Provide a~~ An actuarial study prepared by a qualified actuary determining adequate rates for the proposed self-funded worker's compensation plan based upon a fifty percent (50%) confidence level. (3-23-22)()

~~hvi.~~ ~~Feasibility Study. Provide a~~ A self-insurance feasibility study that includes an analysis of the advantages and disadvantages of self insurance as compared to current coverage, and the related costs and benefits. (3-23-22)()

~~ivii.~~ ~~Custodial Agreement. Set up a~~ A custodial agreement with the State Treasurer for securities required to be deposited under Sections 72-301 and 72-302, Idaho Code. (3-23-22)()

~~jviii.~~ Supplemental ~~Information. Provide supplemental~~ information as requested. (3-23-22)()

~~kix.~~ ~~Initial Security Deposit. Prior to final approval, deposit~~ an initial security deposit must be made with the Idaho State Treasurer ~~in the form permitted by per~~ Section 72-301, Idaho Code, or a self-insurer's bond in substantially the form as the Commission's self-insurer's compensation bond, available on the Commission's website, in the amount of one hundred fifty thousand dollars (\$150,000), plus five percent (5%) of the first ten million dollars (\$10,000,000) of the employer's average annual Payroll in the state of Idaho for the three (3) preceding years; along with such additional security as may be required by the Commission based on prior claims history. (3-23-22)()

~~lx.~~ ~~Initial Guaranty Agreement. The Commission may allow or, w~~ Where financial reports or other factors such as the high risk industry of the employer indicate the need, the Commission may require an employer that is organized as a joint venture or a wholly owned subsidiary to provide an initial guaranty agreement from each member of the joint venture or the parent company. This guaranty agreement confirms the continuing agreement of each of the joint venture members or the parent company to guarantee the payment of all Idaho worker's

compensation claims of employees of that joint venture or subsidiary employer. The guaranty agreement shall be in substantially the same form as the ~~current sample~~ Self-insured Indemnity and Guaranty Agreement and, as applicable, the companion Consent of the Board of Directors, both available on the Commission's website.

(3-23-22)()

~~m.~~ Written Approval. Obtain written approval from the Industrial Commission. (3-23-22)

~~nxi.~~ Idaho National Laboratory. An employer meeting the requirements of Section 72-301A, Idaho Code, does not have to comply with the requirements of Paragraphs 302.02.a., 02.f., 02.i., and 02.k., above. (3-23-22)

302. RULES GOVERNING CONTINUING REQUIREMENTS TO UNDERWRITE INSURANCE OR SELF-INSURE.

01. Insurance Carriers. An insurance carrier approved under IDAPA 17.01.01.301.01 shall comply with the following requirements: (3-23-22)

a. Maintain Statutory Security Deposits with the State Treasurer. (3-23-22)

i. Each insurance carrier shall maintain with the Idaho State Treasurer a security deposit in the amount of twenty-five thousand dollars (\$25,000) if approved by the Commission prior to July 15, 1988, or two hundred and fifty thousand dollars (\$250,000) if approved subsequently. (3-23-22)

ii. In addition to the security required in Subsection 01.a.i, of this rule, each insurance carrier shall deposit an amount equal to the total unpaid outstanding awards of said insurance carrier. Such deposit shall be in the form permitted by Section 72-301, Idaho Code. Surety bonds shall be in the form available on the Commission's website. If a surety bond is deposited, the surety company shall be completely independent of the principal and authorized to transact such business in the state of Idaho. A partial release of security deposited hereunder must be requested in writing and approved by the Commission. (3-23-22)

~~iii. Securities which are maintained to satisfy the requirements of this rule may be held in the federal reserve book entry system, as defined in Section 41-2870(4), Idaho Code, and interests in such securities may be transferred by bookkeeping entry in the federal reserve book entry system without physical delivery of certificates representing such securities.~~ (3-23-22)

b. Appoint Agent for Service of Process. Each insurance carrier shall appoint the Director of the Department of Insurance as its agent to receive service of legal process. (3-23-22)

c. Maintain Resident Idaho Office. Each insurance carrier shall maintain a Claims Administrator employing an Idaho licensed resident adjuster or the carrier's own adjusting offices or officers residing in Idaho. (3-23-22)

i. Each authorized insurance carrier shall notify the Commission ~~Secretary~~ Secretary in writing of any change of the designated resident adjuster(s) to the primary claims administrator within fifteen (15) days of such change and report the designated claims administrator for every insured Idaho employer ~~within fifteen (15) days of such change through proof of coverage (POC).~~ (3-23-22)()

ii. Each authorized insurance carrier will ensure that every in-state adjuster can classify and identify all claims adjusted on behalf of said insurance carrier, and that the in-state adjuster will provide such information to the Industrial Commission upon request. Further each in-state Adjustor must have full authority to: (3-23-22)

(1) Investigate and adjust all claims for compensation; (3-23-22)

(2) Pay all compensation benefits due; (3-23-22)

(3) Accept service of claims, applications for hearings, orders of the Commission, and all process which may be issued under the Worker's Compensation Law; (3-23-22)

- (4) Enter into compensation agreements and LSSs SAs with Claimants; (3-23-22)()
- (5) Provide at the employer's expense necessary forms to any employee who wishes to file a Claim under the Worker's Compensation Law. (3-23-22)
- d.** Supply Forms. Each insurance carrier shall distribute the required forms prescribed by the Commission to all employers it insures. A list of required forms is available on the Commission's website. (3-23-22)
- e.** Comply with Industrial Commission Reporting Requirements. Each insurance carrier shall, within the time prescribed, file such reports and respond to such information requests as the Commission may require from time to time concerning matters under the Worker's Compensation Law. (3-23-22)
- f.** Report Proof of Coverage. (3-23-22)
- i.** Each insurance carrier shall report all proof of coverage to National Council on Compensation Insurance (NCCI). NCCI is the designated agent to receive, process, and forward the proof of coverage information required by these rules to the Commission. The address of the Commission's designated agent is available on the Commission's website. (3-23-22)()
- ii.** The Industrial Commission adopts the IAIABC's electronic proof of coverage record layout and transaction standards as the required reporting mechanism for new policies, renewal policies, endorsements, cancellations, and non-renewals of policies. A copy of the record layout, data element requirements, and transaction standards is available on the Commission's website. Each insurance carrier shall report data for all mandatory elements in the current IAIABC proof of coverage record layout and transaction standards on each policy reported. (3-23-22)
- iii.** The most recent proof of coverage information contained in the Industrial Commission's database shall be presumed to be correct for the purpose of determining the insurance carrier providing coverage. (3-23-22)
- g.** Report New Policy, Renewal Policy, and Endorsement Information Within Thirty Days. Each insurance carrier shall report the issuance of any new worker's compensation policy, renewal policy, or endorsement to the Industrial Commission or its designated agent within thirty (30) days of the effective date of the transaction. (3-23-22)
- h.** Report Cancellation and Non-Renewal of Policy Within Time Prescribed by Statute. Each insurance carrier shall report the cancellation and/or nonrenewal of any worker's compensation insurance policy to the Industrial Commission or its designated agent within the time frames prescribed by Section 72-311, Idaho Code. Receipt of cancellation or nonrenewal notices by the Commission's designated agent shall be deemed to have been received by the Commission. (3-23-22)
- i.** Report Election of Coverage on Form IC52 or Similar Format. Each insurance carrier shall report election of coverage or revocation of election of coverage on or in a format substantially the same as Form IC52, "Election of Coverage," available on the Commission's website. (3-23-22)
- j.** Report Deductible Policy. On or before March 3rd of each year, every insurance carrier shall submit a report of all deductible policies that were issued and in effect during the previous calendar year. That report shall be submitted in a form substantially similar to the current "Deductible Policy Report" available on the Commission's website. The report shall include the following information: insured name, policy number, effective and expiration dates, deductible amount, the premium charged for the policy before credit for the deductible, and the final premium after credit for the deductible. (3-23-22)
- k.** Report Outstanding Awards. Each insurance carrier shall report to the Industrial Commission at the end of each calendar quarter, or more often as required by the Commission, any outstanding award. (3-23-22)
- i.** The report of outstanding awards shall be filed with the Industrial Commission by the end of the month following the end of each calendar quarter. (3-23-22)

ii. The report shall be filed even if there are no outstanding awards. In that event, the carrier shall certify the fact that there are no outstanding awards to be reported. (3-23-22)

iii. The report shall be submitted ~~on~~ in a manner as prescribed by the Industrial Commission or in a format that is substantially the same as the current Form IC36A, "Report of Outstanding Awards - Insurance Carriers" available on the Commission's website. The report may be produced as a computerized spreadsheet or database printout. (3-23-22)()

iv. ~~The report~~ Reports submitted in a format other than online filing, such as hard copy or email attachment, shall be signed and certified to be correct by a corporate officer. If an insurance carrier has designated more than one adjuster for worker's compensation claims in Idaho, a corporate officer of the insurance carrier shall prepare, certify, and file a consolidated report of outstanding awards. (3-23-22)()

v. The report shall list all outstanding awards, commencing with the calendar quarter during which the award is made or benefits are first paid, whichever occurs earlier. (3-23-22)

~~1. Comply with Law and Rules. Each insurance carrier shall comply with the statutes of the state of Idaho and the rules of the Industrial Commission to ensure that payments of compensation shall be sure and certain and not unnecessarily delayed.~~ (3-23-22)

02. Self-Insured Employers. A self-insured employer approved under Subsection 301.02 shall comply with the following requirements: (3-23-22)

a. Payroll Requirements. Maintain an average annual Idaho Payroll over the preceding three (3) years of at least ~~four~~ seven million dollars (\$~~4~~7,000,000), if such employer was originally approved by the Commission subsequent to June 30, 2025, and four million dollars (\$4,000,000), if such employer was originally approved by the Commission prior to July 1, 2025. Any self-insured employer that does not meet the Payroll requirement of this rule for two consecutive semi-annual premium tax reporting periods shall be allowed to maintain their self-insured status for six (6) months from the end of the last reporting period in order to permit them time to increase their Payroll or obtain worker's compensation coverage with an insurance carrier authorized to write worker's compensation insurance in the state of Idaho. (3-23-22)()

b. Security Deposit with Treasurer. (3-23-22)

i. Maintain a primary security deposit with the Idaho State Treasurer in the form permitted by Section 72-301, Idaho Code, a self-insurer's bond form available on the Commission's website, or in substantially the same form, or in such other form approved by the Commission, in the amount of one hundred fifty thousand dollars (\$150,000), plus five percent (5%) of the employers' average annual Payroll in the state of Idaho for the three (3) preceding years, not in excess of ten million dollars (\$10,000,000). If a surety bond is deposited, the surety company shall be completely independent of the principal and authorized to transact such business in the state of Idaho. In addition thereto, the self-insured employer shall deposit additional security in such amount as the Commission determines is necessary to secure the self-insured employer's total unpaid liability for compensation under the Worker's Compensation Law. No approved security shall be accepted for deposit above its par value. Additional deposits of approved security may be required semi-annually if the market value of an approved investment falls below its par value or if the total value of the employer's security deposit falls below the total security required to be maintained on deposit when calculated in accordance with this rule. (3-23-22)

ii. Self-insured employers shall receive a credit for the primary security deposit against the self-insured employer's obligation to post the additional security required by Subparagraph 302.02.b.i. of this rule. (3-23-22)

iii. Excess insurance coverage approved by the Commission may apply as a credit against the self-insured employer's obligation to post the additional security required by Subparagraph 302.02.b.i. of this rule. The Commission must be provided with thirty (30) days advance written notice of any change or cancellation of an approved excess insurance policy. No credit will be given for any excess insurance coverage provided by a surplus lines carrier, as described in Chapter 12, Title 41, Idaho Code. (3-23-22)

~~iv. All security deposited by the self-insured employer shall be maintained as provided by Section 72-302, Idaho Code.~~ (3-23-22)

v. Any withdrawal or partial release of security deposited hereunder must be requested in writing and approved by the Commission. Only one (1) request may be made per calendar year. (3-23-22)()

c. Continue or Provide Guaranty Agreement. (3-23-22)

i. A self-insured employer that is organized as a joint venture or a wholly owned subsidiary shall continue in effect any guaranty agreement that the Commission has previously allowed or required, until termination is permitted by the Commission. (3-23-22)

ii. Where an adverse change in financial condition or other relevant factors such as claims history or industry risk indicates the need, a self-insured employer that is organized as a joint venture or a wholly owned subsidiary may be allowed to, or shall upon request, provide a guaranty agreement from each member of the joint venture or the parent company. This guaranty agreement confirms the continuing agreement of each of the joint venture members or the parent company to guarantee the payment of all Idaho worker's compensation claims of employees of that joint venture or subsidiary self-insured employer. The guaranty agreement shall be in substantially the same form as the current sample Indemnity and Guaranty Agreement, and as applicable, the companion Consent of the Board of Directors, available on the Commission's website. (3-23-22)

d. Maintain a Licensed Resident Adjuster. Maintain an Idaho licensed, resident claims adjuster located within the state of Idaho who shall have full authority to make decisions and to authorize the payment of all compensation on said claims on behalf of the employer including, but not limited to, the following: (3-23-22)

i. Investigate and adjust all claims for compensation; (3-23-22)

ii. Pay all compensation benefits due; (3-23-22)

iii. Accept service of claims, applications for hearings, orders of the Commission, and all process which may be issued under the Worker's Compensation Law; (3-23-22)

iv. Enter into compensation agreements and ~~LSSs~~ SAs with Claimants; (3-23-22)()

v. Provide at the employer's expense necessary forms to any employee who wishes to file a Claim under the Worker's Compensation Law. (3-23-22)

e. File Reports. Report to the Industrial Commission semi-annually, or more often as required by the Commission, total unpaid liability on all open claims. (3-23-22)

i. The semi-annual report of total unpaid liability shall be filed with the Industrial Commission by the end of the months of January and July. (3-23-22)

ii. The report shall provide the aggregate number of open claims, including indemnity with medical and Medical Only Claims, along with the amount of any compensation paid on open claims, as of the end of each June and December. (3-23-22)

iii. The report shall be filed even if there are no open claims. In that event, the employer shall certify the fact that there are no open claims to be reported. (3-23-22)

iv. The report shall be submitted on or in a manner as prescribed by the Industrial Commission or in a format that is substantially the same as the current Form IC-211, "Self-Insured Employer Report of Total Unpaid Liability," available on the Commission's website. The report may be produced as a computerized spreadsheet or database printout. (3-23-22)()

v. ~~The report~~ Reports submitted in a format other than online filing, such as hard copy or email

attachment, shall be signed and certified to be correct by a corporate officer. If an employer has designated more than one adjuster for worker's compensation claims in Idaho, a corporate officer of the employer shall prepare, certify, and file a consolidated report of all unpaid liability. (3-23-22)()

vi. A self-insured employer shall also make, within the time prescribed, such other reports and respond to such information requests as the Commission may require from time to time concerning matters under the Worker's Compensation Law. (3-23-22)

f. Submit to Audits by Industrial Commission. Each year a self-insured employer shall provide the Industrial Commission with a copy of its annual financial statements, or other acceptable documentation. Each self-insured employer shall submit to audit by the Commission or its designee at any time and as often as it requires to verify the amount of premium such self-insured employer would be required to pay as premium to the State Insurance Fund, and to verify compliance with the provisions of these rules and the Idaho Worker's Compensation Law. For the purpose of determining such premium for uninsured contractors of a self-insured employer, the most recent proof of coverage information contained in the Industrial Commission's database shall be presumed to be correct for the purpose of determining such coverage. (3-23-22)

~~g. Comply with Law and Rules. Comply with the statutes of the state of Idaho and the rules of the Industrial Commission to the end that payment of compensation shall be sure and certain and not unnecessarily delayed. The Commission may withdraw its approval of any employer to operate as a self insurer if it shall appear to the Commission that workers secured by said self-insured employer are not adequately protected and served, or the employer is failing to comply with the provisions of these rules or the Worker's Compensation Law.~~ (3-23-22)

hg. Idaho National Laboratory. An employer meeting the requirements of Section 72-301A, Idaho Code, does not have to comply with Paragraph 303.02.a. and 302.02.b., above. (3-23-22)

303. RULE GOVERNING THE COLLECTION OF PREMIUM TAX ON WORKER'S COMPENSATION INSURANCE POLICIES.

~~This rule governs the collection of premium tax on worker's compensation insurance policies. This procedure applies to all worker's compensation policies.~~ (3-23-22)

01. **Procedure for Submitting Premium Tax Forms.** The form IC 4008, ~~available on the Commission's website,~~ to be filed in the manner prescribed by the Commission, shall be used to report numbers of policies and the total gross premiums written. ~~The original shall be sent to the Commission; a~~ A copy shall also must be attached to the reporting entity's annual premium tax statement that is filed with the Idaho Department of Insurance. Forms submitted in a format other than online filing, such as hard copy or email attachment, shall be signed and certified to be correct by a corporate officer. This form is due to the Commission by July 31 for the reporting period of January 1 through June 30; it is due by March 3 for the reporting period of July 1 through December 31. (3-23-22)()

304. RULE GOVERNING PREMIUM TAX COMPUTATION FOR SELF-INSURED EMPLOYERS.

01. **Payroll Reports.** ~~No later than March 3rd and July 31st, self-insured employers shall file a semi-annual premium tax report with the Fiscal Department of the Commission.~~ Self-insured employers shall use file in the manner prescribed by the Commission's ~~current report a~~ form IC 4010, along with the accompanying computation form IC 4010a, ~~available on the Commission's website.~~ Forms submitted in a format other than online filing, such as hard copy or email attachment, shall be signed and certified to be correct by a corporate officer. The premium tax payment due ~~from a self-insured employer~~ shall be based upon the manual premium calculated for each reporting period, as modified by an experience modification factor calculated by NCCI and submitted to the Commission in accordance with Subsection 304.02 of this rule. No other rating factor shall be allowed. If the self-insured employer elects to not provide such experience modification factor, the premium tax will be computed based upon the manual premium only. (3-23-22)()

02. **Experience Modification.** A self-insured employer that elects to use an experience modification factor in computing premium tax shall make an annual application to NCCI for an experience modification factor using the NCCI form ERM-6 and paying to NCCI any fees charged for providing that calculation. An NCCI experience modification factor may only be based on the employer's Idaho operations for which self-insured status is

authorized. In order to have an experience modification factor considered for any reporting period, an employer must timely submit to the Commission's Fiscal Department: (3-23-22)

- a. A copy of the completed form ERM-6 filed with NCCI; (3-23-22)
- b. The resulting experience modification factor received from NCCI; and (3-23-22)
- c. The completed IC 4010 Semi-Annual Premium Tax Form for Self-Insurers and IC 4010a Computation Form. (3-23-22)

305. REQUIREMENTS FOR MAINTAINING IDAHO WORKER'S COMPENSATION CLAIMS FILES.

~~All insurance carriers, self-insured employers, and licensed adjusters servicing Idaho worker's compensation claims shall comply with the following requirements:~~ (3-23-22)

01. Idaho Office. (3-23-22)

a. All insurance carriers, self-insured employers, and licensed adjusters servicing Idaho worker's compensation claims shall maintain an office within the state of Idaho. ~~The offices shall be staffed by adequate personnel to conduct business.~~ (3-23-22)()

b. The insurance carrier or self-insured employer shall authorize and require a member of its in-state staff or an Idaho licensed resident adjuster to service and make decisions regarding claims pursuant to Section 72-305, Idaho Code. (3-23-22)

c. As staffing changes occur and, at least annually, the insurance carrier, self-insured employer, or licensed adjuster shall submit to the Commission Secretary the names of those authorized to make decisions regarding claims pursuant to Section 72-305, Idaho Code. Each authorized insurance carrier shall designate only one (1) Claims Administrator for each policy of worker's compensation insurance. (3-23-22)

02. Claim Files. All Idaho worker's compensation claim files shall be maintained within the state of Idaho in either hard copy or immediately accessible electronic format. Claim files shall include, ~~but are not limited to~~ all documents relevant to the claim file: (3-23-22)()

- a. FROI and Claim for Benefits; (3-23-22)
- b. Copies of bills for medical care; (3-23-22)
- c. Copy of lost-time computations, if applicable; (3-23-22)
- d. Correspondence reflecting reasons for any delays in payments, the resolution of such delays, and acceptance or denial of compensability; (3-23-22)
- e. Employer's return-to-work communications; and (3-23-22)
- f. Medical reports. (3-23-22)

03. Correspondence. All original correspondence involving adjusting decisions regarding Idaho worker's compensation claims shall be authorized ~~from and maintained at in-state offices~~ and accessible through electronic reproduction by the resident Idaho adjuster. (3-23-22)()

04. Date Stamp. Each of the documents listed in Subsections 305.02 and 305.03, above, shall be date-stamped with the name of the receiving office on the day received, and by each receiving agent or vendor acting on behalf of the claims office. (3-23-22)

05. Notice and Claim. All First Reports of Injury, Claims for Benefits, notices of occupational illnesses, and fatalities shall be sent directly to the in-state adjuster for the insurance carrier or self-insured employer.

~~The original copy~~ An EDI Filing of the FROI, Claim for Benefits, and notices of occupational illness and fatality shall be sent electronically to the Industrial Commission. (3-23-22)()

06. Compensation Payments - Generally. (3-23-22)

a. All compensation, as defined by Section 72-102, Idaho Code, must be issued from the in-state office. (3-23-22)

b. Except as ordered otherwise by the Commission, the insurance carrier or self-insured employer may make compensation payments by either: (3-23-22)

i. Check or other readily negotiable instrument; (3-23-22)

ii. ~~When requested by the Claimant, electronic transfer payment to an account designated by the Claimant in accordance with the requirements of Subsection 305.07; or~~ Upon the Claimant's written request, through an electronic payment transfer to an account designated by the Claimant. The Claimant or Claimant's attorney may discontinue receiving the electronic transfer payment and revert to receiving compensation payments via check by written notification; or (3-23-22)()

iii. ~~When requested by the Claimant, electronic transfer payments made through an access card; if that option is made available by the carrier or self-insured employer, in accordance with the requirements of Subsection 305.08~~ An insurance carrier or a self-insured employer may pay compensation through either: (1) an automated teller machine (ATM) card, (2) debit card, or (3) access card (hereinafter, collectively referred to as an "access card") to a Claimant if there is a signed agreement between the insurance carrier or self-insured employer and the Claimant. An insurance carrier or self-insured employer shall not reduce compensation payments paid to a Claimant through an access card for any fees, surcharges, and adjustments unless they are for direct costs in replacing an access card through an expedited mail service, international transaction fees, or out-of-network ATM fees. The Claimant or Claimant's attorney may discontinue receiving payment via access card by written notification.- (3-23-22)()

c. Notwithstanding subsection (ii) and (iii) above If the Claimant is represented by an attorney who may have an attorney's lien for fees due on such compensation payments, the attorney must agree to payment by electronic transfer to Claimant's account or payment through an access card before such compensation may be paid other than by a check made payable to the Claimant and the attorney. Upon request, updated electronic payment history shall be provided by written notification to represented parties. (3-23-22)()

07. Electronic Transfer Payments. (3-23-22)

~~a. A Claimant may request that the insurance carrier or self-insured employer make compensation payments by electronic transfer to a personal bank account by providing the insurance carrier or self-insured employer in writing: the name and routing transit number of the financial institution and the account number and type of account to which the Claimant wants to have the compensation electronically transferred. The insurance carrier or self-insured employer shall provide the Claimant with a written form to fill out the required information by this subsection within seven (7) days of receiving a request for electronic transfer of payments from the Claimant unless the Claimant has already completed an on-line electronic form provided by the carrier or employer.~~ (3-23-22)

~~b. The insurance carrier or self-insured employer may make compensation payments to the Claimant by electronic transfer to an account designated by the Claimant if the Claimant:~~ (3-23-22)

~~i. Requests in writing that payment be made by electronic transfer;~~ (3-23-22)

~~ii. Provides the information required by Paragraph 305.07.a. above; and~~ (3-23-22)

~~iii. Is reasonably expected to be entitled to receive compensation payments for a period of eight (8) weeks or more from the point that Subparagraphs 305.07.b.i. and 07.b.ii. are satisfied.~~ (3-23-22)

~~e. The insurance carrier or self-insured employer shall initiate payment by electronic transfer starting with the first benefit payment due on or after the twenty first day after the requirements of Paragraph 305.07.b., above~~

~~are met, but shall continue to make timely payments by check until the insurance carrier or self-insured employer initiates benefit payment delivery by electronic transfer. (3-23-22)~~

~~d. If the Claimant has previously been receiving benefit payments by electronic transfer and wants to receive benefits by check, the insurance carrier or self-insured employer shall initiate benefit payment delivery by check starting with the first benefit payment due to the Claimant on or after the seventh day after receiving a written request for such payments. (3-23-22)~~

~~**08. Access Card Payments. (3-23-22)**~~

~~a. Access card means any card or other payment method that may be used by a Claimant to initiate electronic fund transfer from an insurance carrier's or a self-insured employer's bank account. The term "access card" does not include stored value cards or prepaid cards that store funds directly on the card and that are not linked to an insurance carrier's or a self-insured employer's bank account. (3-23-22)~~

~~b. An insurance carrier or a self-insured employer may pay compensation through an access card to a Claimant if there is written mutual agreement signed by the insurance carrier or self-insured employer and the Claimant. The insurance carrier or self-insured employer shall maintain accurate records of the mutual agreement for, at a minimum, four hundred and one (401) weeks from the date of injury. The written agreement shall contain an acknowledgment that the Claimant received and agreed to the written disclosure required by Paragraph 305.08.d. (3-23-22)~~

~~e. An insurance carrier or a self-insured employer providing compensation payments to a Claimant through an access card shall: (3-23-22)~~

~~i. Permit the Claimant to withdraw the entire amount of the balance of an access card in one transaction; (3-23-22)~~

~~ii. Not reduce compensation payments paid to a Claimant through an access card for the following fees, surcharges, and adjustments: (3-23-22)~~

~~(1) Overdraft services under which a financial institution pays a transaction (including a check or other item) when the Claimant has insufficient or unavailable funds in the account; (3-23-22)~~

~~(2) ATM withdrawal or point of sale purchase for more than the card holds and the transaction is denied; (3-23-22)~~

~~(3) ATM balance inquiries; (3-23-22)~~

~~(4) Withdrawing money from network ATMs; (3-23-22)~~

~~(5) Withdrawing money from a teller; (3-23-22)~~

~~(6) Customer service calls; (3-23-22)~~

~~(7) Activating the card; (3-23-22)~~

~~(8) Fees for card inactivity; (3-23-22)~~

~~(9) Closing account; (3-23-22)~~

~~(10) Access card replacement through standard mail; (3-23-22)~~

~~(11) Withdrawing the entire payment in one transaction; (3-23-22)~~

~~(12) Point of sale purchases, or (3-23-22)~~

- ~~(13) Any other fees or charges that are not authorized under Subparagraph 305.08.e.iii., and (3-23-22)~~
- ~~iii. Only permit a Claimant to be charged for the following: (3-23-22)~~
- ~~(1) Fees for access card replacement through an expedited mail service; (3-23-22)~~
- ~~(2) International transaction fees, and (3-23-22)~~
- ~~(3) Out-of-network ATM fees. (3-23-22)~~
- ~~d. Insurance carriers or self-insured employers shall provide a written disclosure to the Claimant contemporaneously with the written mutual agreement required under Paragraph 305.08.b. that includes: (3-23-22)~~
- ~~i. A summary of the Claimant's liability for unauthorized electronic fund transfers; (3-23-22)~~
- ~~ii. The telephone number and address of the person or office to be notified when the Claimant believes that an unauthorized electronic fund transfer has been or may be made; (3-23-22)~~
- ~~iii. The type of electronic fund transfers that the Claimant may make and any limitations on the frequency of transfers; (3-23-22)~~
- ~~iv. Any fees imposed for electronic fund transfers or for the right to make transfers, including a statement that fees may be imposed by an ATM operator that is out of network; (3-23-22)~~
- ~~v. Fees for expedited card replacement or international transaction fees will be removed from the balance maintained in the bank account linked to the access card; (3-23-22)~~
- ~~vi. A summary of the Claimant's right to receipts and periodic statements; (3-23-22)~~
- ~~vii. All bank locations and network ATMs in the United States where the Claimant may access his or her funds at no cost; (3-23-22)~~
- ~~viii. A statement informing the Claimant that they have a right to receive payments directly into their personal bank account through direct deposit or by check. (3-23-22)~~
- ~~e. An insurance carrier or a self-insured employer shall provide the written disclosure and any notice of term or condition changes required under Paragraph 305.08.d. that: (3-23-22)~~
- ~~i. Are printed in not less than twelve (12) point font; (3-23-22)~~
- ~~ii. Include the full text to communicate all terms and conditions; (3-23-22)~~
- ~~iii. Are written in a clear and coherent manner and wherever practical, words with common and everyday meaning shall be used to facilitate readability; and (3-23-22)~~
- ~~iv. Are appropriately divided and captioned in a meaningful sequence such that each section contains an underlined, boldfaced, or otherwise conspicuous title or caption at the beginning of the section that indicates the nature of the subject matter included in or covered by the section. (3-23-22)~~
- ~~f. An access card issued to a Claimant under this Subsection 305.08 shall: (3-23-22)~~
- ~~i. Not bear any information that could reasonably identify the Claimant as a participant in the worker's compensation system; and (3-23-22)~~
- ~~ii. Include on the front or back of the access card a toll-free customer service number and website address. Customer service personnel shall be available by phone Monday through Friday during normal business hours (9 a.m. to 6 p.m. Mountain Time). (3-23-22)~~

~~g.~~ The insurance carrier or self-insured employer shall provide a written notice to the Claimant at least twenty one (21) days before the effective date of any change in a term or condition of the mutual agreement or disclosure, including terminating the access card program, increased fees, or liability for unauthorized electronic fund transfers. Any terms or conditions that violate the requirements of this Subsection 305.08 are null and void and may result in administrative action against the carrier or employer. An insurance carrier or employer shall provide a written notice of term or condition changes that: (3-23-22)

- ~~i.~~ Provides a comparison of the current terms and the changes; and (3-23-22)
- ~~ii.~~ References the Claimant's ability to request a change in method of payment to electronic fund transfer to his or her personal bank account in accordance with Subsection 305.07 or to payment by check. (3-23-22)

~~h.~~ An insurance carrier or a self-insured employer may close the access card account by issuing a check to the Claimant with the remaining balance of the access card if the account has been inactive for twelve (12) months or longer. (3-23-22)

~~i.~~ The insurance carrier or self-insured employer shall not remove money from the Claimant's account or access card except to remove permitted fees under Subparagraph 305.08.e.iii. or to close the account for inactivity of a period of twelve (12) months or more. An insurance carrier or a self-insured employer seeking to recoup overpayments shall follow the requirements of section 72-316, Idaho Code. (3-23-22)

~~j.~~ An insurance carrier or a self-insured employer is considered to have made a compensation payment the date the payment is available on the Claimant's access card. (3-23-22)

097. **Checks and Drafts.** Checks must be signed and issued within the state of Idaho; drafts are prohibited. (3-23-22)

a. The Commission may, upon receipt of a written Application for Waiver, grant a waiver from the provisions of Subsections 305.06 and ~~305.09~~ this Subsection of this rule to permit an insurance carrier or a self-insured employer to sign and issue checks outside the state of Idaho. (3-23-22)()

b. An Application for Waiver must be accompanied by an affidavit signed by an officer or principal of the insurance carrier or self-insured employer, attesting to the fact that the insurance carrier or self-insured employer is prepared to comply with all statutes and rules pertaining to prompt payments of compensation. (3-23-22)

c. All waivers shall be effective from the date the Commission issues the order granting the waiver. A waiver shall remain in effect until revoked by the Industrial Commission. At least annually, staff of the Industrial Commission may review the performance of any insurance carrier or self-insured employer for which a waiver under this rule has been granted to assure that the insurance carrier or self-insured employer is complying with all statutes and rules pertaining to prompt payments of compensation. (3-23-22)

d. If at any time after the Commission has granted a waiver, the Commission receives information permitting the inference that the insurance carrier or self-insured employer has failed to provide timely benefits to any Claimant, the Commission may issue an order to show cause why the Commission should not revoke the waiver; and, after affording the insurance carrier or self-insured employer an opportunity to be heard, may revoke the waiver and order the insurance carrier or self-insured employer to comply with the requirements of Subsections 305.06 and ~~305.09~~ this Subsection of this rule. (3-23-22)()

~~408.~~ **Copies of Checks.** Copies of checks and/or electronically reproducible copies of the information contained on the checks must be maintained in the in-state files for Industrial Commission audit purposes. ~~A copy~~ Notice of the first income benefit check shall be sent to the Industrial Commission electronically on the same day of issuance. (3-23-22)()

~~409.~~ **Prompt Claim Servicing.** Prompt claim servicing includes, but is not limited to: (3-23-22)

- a.** Making an initial decision to accept or deny a Claim for an injury or occupational disease within

thirty (30) days of the date the Claims Administrator receives knowledge of the same. The worker shall be given notice of that initial decision in accordance with Section 72-806, Idaho Code. Nothing in this rule shall be construed as amending the requirement to start payment of income benefits no later than four (4) weeks or twenty-eight (28) days from the date of disability under the provisions of Section 72-402, Idaho Code. (3-23-22)

b. Payment of medical bills in accordance with the provisions of Section 803 of these rules. (3-23-22)

c. Payment of income benefits on a weekly basis, unless otherwise approved by the Commission. (3-23-22)

i. The first payment of income benefits under Section 72-408, Idaho Code, shall constitute application by the insurance carrier or self-insured employer for a waiver to pay Temporary Total Disability (TTD) benefits on a bi-weekly basis, Temporary Partial Disability (TPD) benefits on other than a weekly basis, Permanent Partial Disability (PPD) benefits based on permanent impairment and Permanent Total Disability (PTD) benefits every twenty-eight (28) days, rather than on a weekly basis. (3-23-22)

ii. Such waiver application shall be granted upon receipt and remain in effect unless revoked by the Industrial Commission in accordance with Subparagraph 305.11.c.iii. (3-23-22)

iii. If at any time after a waiver has been granted pursuant to this section the Commission receives information permitting the inference that the insurance carrier or self-insured employer has failed to service claims in accordance with Idaho law, or that such waiver has created an undue hardship on a Claimant, the Commission may issue an order to show cause why the Commission should not revoke that waiver, and after affording the insurance carrier or employer an opportunity to be heard, may revoke the waiver with respect to all or certain Claimants and order the insurance carrier or self-insured employer to comply with the requirements of Subsection 305.11.c. of this rule. (3-23-22)

d. Payment of the first Permanent Partial Disability (PPD) benefit based on permanent impairment no later than fourteen (14) days after receipt of the Medical Report providing the impairment rating. The first payment shall include payment of benefits retroactive to the date of medical stability. (3-23-22)

e. Temporary Partial Disability (TPD) payments ~~shall~~ may be calculated using the employee's pay period, whether weekly, bi-weekly, or semi-monthly. ~~For employees paid pursuant to any other schedule, TPD benefits shall be calculated semi-monthly.~~ TPD payments owed for a particular pay period shall issue no later than seven (7) days following the date on which employee is ordinarily paid for that pay period. (3-23-22)()

~~120.~~ **Audits.** The Industrial Commission ~~will~~ may perform ~~periodic~~ audits to ensure compliance with the above requirements. (3-23-22)()

~~131.~~ **Non-Compliance.** Non-compliance with the above requirements may result in the revocation of the authority of an insurance carrier to write worker's compensation insurance or self-insured employer to self-insure its worker's compensation insurance obligations in the state of Idaho, or such lesser sanctions as the Industrial Commission may impose. (3-23-22)

306. RULE PROHIBITING USE OF SICK LEAVE OR OTHER ALTERNATIVE COMPENSATION.

01. Employee Not Required to Take Sick Leave in Lieu of Compensation. No employer obligated to pay worker's compensation benefits to an employee as provided by the Worker's Compensation Law may require an employee to accept "sick leave" or other comparable benefit in lieu of the worker's compensation benefits provided by law. ~~Section 72-318(2), Idaho Code, specifically provides that no agreement by an employee to waive his rights to compensation under the Worker's Compensation Law shall be valid.~~ (3-23-22)()

02. Election of Sick Leave or Alternative Compensation Prohibited. Further, an employee may not elect to accept "sick leave" or other comparable benefit from an employer in lieu of worker's compensation benefits to which the employee is entitled under the Worker's Compensation Law. (3-23-22)

307. RULE GOVERNING REPORTING INDEMNITY AND MEDICAL PAYMENTS AND MAKING PAYMENT OF INDUSTRIAL SPECIAL INDEMNITY FUND (ISIF) ASSESSMENT.

Pursuant to Section 72-327, Idaho Code, the state insurance fund, every authorized insurance carrier, and self-insured employer in Idaho shall report annually to the Industrial Commission the total gross amount of medical only and Indemnity Benefits paid on Idaho worker's compensation claims during the applicable reporting period. This report is The reported indemnity payments only are used to calculate the pro rata share of the annual assessment for the ISIF, under Section 72-327, Idaho Code. (3-23-22)()

01. Filing. The report of indemnity and medical payments shall be filed with the Industrial Commission simultaneously with the first Semi-Annual Premium Tax Report; which, pursuant to Section 72-523, Idaho Code, is due each year on March 3rd. (3-23-22)

02. Form. The report of indemnity and medical payments shall be submitted ~~in writing on, or in a format substantially the same as the current Form IC2-327, available on the Commission's website~~ on Form IC2-327 in the manner prescribed by the Industrial Commission. (3-23-22)()

03. Report Required When No Indemnity Paid. If an entity required to report under this rule has no claims against which indemnity or medical payments have been made during the reporting period, a report shall be filed so indicating. (3-23-22)

04. Penalty for Late Filing. A penalty shall be assessed by the Commission for filing the report of indemnity and medical payments later than March 3rd each year. (3-23-22)

a. A penalty of two hundred dollars (\$200) for late filing of seven (7) days or less. (3-23-22)

b. A penalty of one hundred dollars (\$100) per day for late filing of more than seven (7) days. (3-23-22)

c. A penalty assessed by the Commission shall be payable to the Industrial Commission and be submitted with the April 1 payment of the ISIF assessment, following notice by the Commission of the penalty assessment. (3-23-22)

05. Estimating Indemnity Payments for Entities That Fail to Report Timely. If an entity required to report indemnity payments under these rules fails to report within the time allowed in these rules, the Commission will estimate the indemnity payments for that entity by using the indemnity amount reported for the preceding reporting period and adding twenty percent (20%). (3-23-22)

06. Adjustment for Overpayments or Underpayments. Overpayments or underpayments, including those resulting from estimating the indemnity payments of entities that fail to report timely, will be adjusted on the billing for the subsequent period. (3-23-22)

308. – 400. (RESERVED)

401. RULE GOVERNING COMPUTATION OF AVERAGE WEEKLY WAGE.

01. Amounts Paid over Base Rate. Sums paid by an employer to an employee, over and above the base rate of compensation agreed upon by the employer and the employee in a contract of hire, which are contingent and dependent upon the employee's increased physical exertion and/or efficiency shall be included in computing the employee's average weekly wage pursuant to Section 72-419(4)(a), Idaho Code. Said sums shall not be considered premium pay. (3-23-22)

02. Fringe Benefits. Also, in computing the average weekly wage, it shall be presumed that wages include, but are not limited to, cost of living increases, vacation pay, holiday pay, and sick leave. (3-23-22)

03. Premium Pay. Further, in computing the average weekly wage, it shall be presumed that premium pay includes, but is not limited to, shift differential pay and overtime pay. (3-23-22)

04. Examples Not Exclusive. The above-listed examples ~~shall not be taken as~~ are not exclusive in computing the average weekly wage. (3-23-22)()

402. RULE GOVERNING ~~CONVERSION OF~~ AVERAGE OF MULTIPLE IMPAIRMENT RATINGS ~~TO "WHOLE MAN" STANDARD.~~

~~**01. Converting Single Rating of Body Part to Whole Person Rating.** Impairment ratings shall be converted in accordance with the Industrial Commission Schedule, Section 72-428, Idaho Code, with the base of five hundred (500) weeks for the whole man.~~ (3-23-22)

02. Averaging Multiple Ratings. Where more than one (1) evaluating physician has given ratings, these shall be converted to the statutory percentage of the whole man, and averaged for the applicable rating. (3-23-22)

~~**03. Correcting Manifest Injustice.** In the event that the Commission deems a manifest injustice would result from the above ruling, it may at its discretion take steps necessary to correct such injustice.~~ The Commission may take steps to correct a manifest injustice resulting from averaging multiple ratings. (3-23-22)()

403. RULE GOVERNING COMPENSATION FOR DISABILITY DUE TO LOSS OF TEETH.

01. Compensation for Disability. A Claimant under the Worker's Compensation Law shall be entitled to compensation for permanent disability for the loss of each tooth other than wisdom teeth at the rate of one tenth of one percent (.1%) of the whole man. The loss of wisdom teeth shall not constitute any permanent disability. Compensation hereunder shall be in addition to payments for medical services including dental appliances and bridgework necessitated by the injury and any income benefits during the period of Claimant's recovery to which the Claimant be entitled. (3-23-22)

02. Prima Facie Evidence. This rule and schedule shall be prima facie evidence of the percentage of permanent disability to be attributed to the loss of teeth. (3-23-22)

404. SUBMISSION OF MEDICAL REPORTS FROM PROVIDERS

~~This procedure applies to all open worker's compensation claims where medical services are provided and which have not been denied by the Payor.~~ (3-23-22)

01. Procedure. In all cases in which a particular injury or occupational disease results in a worker's compensation Claim, the Provider shall submit written Medical Reports for each medical visit to the Payor. A medical authorization for release of records signed by Claimant shall remain in effect until revoked. Payors and Providers may contract with one another to identify specific records that will be provided in support of billings. The Provider shall also submit the same written Medical Reports to the Claimant upon request. These reports shall be submitted within fourteen (14) days following each evaluation, examination, and/or treatment. The first copy of any such reports shall be provided to the Payor and the Claimant, or their attorney, at no charge. If duplicate copies of reports already provided are requested by either the Payor or the Claimant, the Provider may charge the requesting party a reasonable charge to provide the additional reports. Whenever possible, billing information shall be coded using CPT. In the case of Hospitals, reports shall include a Uniform Billing Form 04. In the case of physicians and other Providers supplying outpatient services, this reporting requirement shall include a CMS 1500 form. (3-23-22)()

a. If an injury or occupational disease results in a Claim, the Employer/Surety or Provider shall submit written reports to the Commission upon request. Such request may either be in writing or telephonic. If a Claim is referred to the Rehabilitation Division, Medical Reports shall be furnished by the Payor or Provider directly to the office that requests such reports. The Payor or Provider shall consider this an on-going request until notice is received that the reports are no longer required. (3-23-22)

b. If the injury or occupational disease results in a time-loss Claim, the Payor shall submit copies of medical records containing information regarding the beginning and ending of disability, releases to work whether light duty or regular duty, impairment ratings, physical restrictions to the Commission. Other Medical Reports shall

be submitted to the Commission only upon request. (3-23-22)

c. ISIF shall receive all copies of Medical Reports, without charge, from either the Claimant or the Payor, depending upon who seeks to join it as a party to a worker's compensation Claim. (3-23-22)

d. If the Commission requests Medical Reports from the Payor or Provider, the information shall be provided within a reasonable time period without charge. If information is received for which the Commission has no need, the information may be discarded or destroyed. (3-23-22)

02. Report Form and Content. Upon approval of the Commission, Medical Reports may be submitted in electronic or other machine-readable form usable to all parties. (3-23-22)

03. Timely Response Requirement. When the Commission requests a Medical Report from a Payor or Provider for use in monitoring a worker's compensation Claim, the Payor or Provider shall provide the requested information promptly. (3-23-22)

04. Forfeiture of Payment. If a Provider fails to give records to the Payor or Claimant, the Payor or Claimant may petition the Commission for an order requiring the Provider to provide the requested information. The petition shall set forth the Petitioner's efforts to obtain the information, the responses to those efforts, and why the Petitioner believes that the Provider has the information. In response to the petition, the Commission may enter an order requiring the Provider to furnish the requested records or demonstrate that the records are not available. If a Provider fails to provide records when ordered by the Commission, the Commission may enter an Order of Forfeiture. In the event such an order is entered, the Provider will forfeit its right to payment from both the Payor and Claimant, until such time as the records are provided. (3-23-22)

405. RULE GOVERNING REIMBURSEMENT FOR TRAVEL EXPENSES.

~~**01. Mileage Rate.** If Claimant has access to, and is able to operate, a vehicle for transportation covered by Sections 72-432(13) or 72-433(3), Idaho Code, employer shall reimburse Claimant at the mileage rate then allowed by the State Board of Examiners for State employees. Such rate shall be published annually by the Industrial Commission, together with the average state wage for the upcoming period. All such miles shall be reimbursed, with fractions of a mile greater than one-half (1/2) mile rounded to the next higher mile and fractions of a mile below one-half (1/2) mile disregarded. (3-23-22)~~

~~**02. Commercial Transportation.** If Claimant has no vehicle, or has access to a vehicle and is reasonably unable to utilize the vehicle for transportation covered by Sections 72-432(13) or 72-433(3), Idaho Code, Claimant's employer shall reimburse Claimant the actual cost of commercial transportation as evidenced by actual receipts. Notwithstanding the above provision, no Claimant shall be eligible for reimbursement of the actual cost of commercial transportation where such Claimant is unable to operate a motor vehicle due to the revocation or suspension of driving privileges because Claimant was under the influence of alcohol and/or drugs. (3-23-22)~~

~~**03. Request for Reimbursement.** It shall be Claimant's responsibility to submit a travel reimbursement request to the employer. Such request shall be made on a form substantially the same as Industrial Commission Form IC 432(1), posted on the Commission's website. The Claimant must attach to the form a copy of a bill or receipt showing that the visit occurred. The employer shall furnish the Claimant with copies of this form. (3-23-22)~~

~~**04. Frequency of Requests.** Claimant shall not request transportation reimbursement more frequently than once every thirty (30) days. However, notwithstanding this provision, should a Claimant request transportation reimbursement more frequently than every thirty (30) days, employer need not issue more than one reimbursement check in any thirty-day (30) period. (3-23-22)~~

406. -- 500. (RESERVED)

501. RULE GOVERNING PROTECTION AND DISCLOSURE OF REHABILITATION DIVISION RECORDS.

~~01. Request for Disclosure. Pursuant to Section 74-105(10), Idaho Code, a party requesting rehabilitation records shall do so in writing and identify which provision of 74-105(10), Idaho Code, authorizes their request. (3-23-22)~~

021. Requests from Other Agencies. If records are in the possession of the Rehabilitation Division by reason of an agreement to comply with valid confidentiality regulations of any agency of the state of Idaho, or agency of the United States, then disclosure shall be requested from the source agency, and not from the Rehabilitation Division. (3-23-22)

502. RULE GOVERNING REPORTS OF ATTORNEY COSTS AND FEES IN LITIGATED CASES. When requested by the Commission, parties to a Litigated Case shall provide the Commission the information required by Section 72-528, Idaho Code. The form for Sureties is Form 1022 and the form for Claimant's attorneys is Form 1023; both are available on the Commission's website. (3-23-22)

503. -- 600. (RESERVED)

601. SUBMISSION OF FROI AND SROI.

~~01. Purpose. Pursuant to Sections 72-602(1)-(2), Idaho Code, employers must submit a FROI and/or SROI in accordance with these rules. (3-23-22)~~

021. EDI Reporting. The Commission ~~requires electronic submission of FROIs and SROIs in accordance with the most current versions of the~~ adopts the IAIABC EDI Claims Release 3.0, or release 3.1 after September 14, 2023, and the Commission's EDI Guides and Tables's electronic claims record layout and transaction standards as the required reporting mechanism for all initial claim filings and subsequent reports from any employer not otherwise exempt by these rules. ~~Each FROI and SROI must comply with formatting requirements and must contain the information identified as mandatory or mandatory conditional, as applicable~~ The Commission's EDI Claims Guides and Tables are available on the website. (4-6-23)(____)

032. Trading Partner Agreements. Before commencing ~~with~~ electronic reporting, Trading Partners shall electronically submit a Trading Partner Agreement ~~with the Commission~~, which the Commission must approve prior to submitting reports. ~~This agreement must provide the effective date to send and receive electronic reports, the acceptable data to be sent and received, the method of transmission to be used, and other pertinent elements.~~ This agreement will identify the insurance carrier, the Claims Administrator, the sender of the electronic files, and the electronic filing method. To ensure the accuracy of reported data, the Trading Partner must maintain their profile to reflect changes as they occur and the Commission may make periodic audits of Trading Partner files. ~~In the event that~~ If a Trading Partner Agreement is entered into by a Claims Administrator, notice to the Trading Partner of a FROI shall be deemed to be notice to the underlying insurance carrier or self-insured employer. (3-23-22)(____)

043. Report Form and Content for Parties Exempt from EDI Requirements. (3-23-22)

a. Individual ~~injured workers~~ claimants, injured worker's claimant's legal counsel, and employers that are not insured are not required to comply with EDI requirements for FROIs and SROIs. (3-23-22)(____)

b. Parties exempt from EDI requirements must submit FROIs on a form 1A-1 and SROIs on a form IC-8, or in a format substantially similar. Both forms are available on the Commission's website. (3-23-22)

054. Retaining Claims Files. Upon request of the Commission, insurance carriers, Claims Administrators, or employers shall provide to the Commission, in whole or in part according to the request, a copy of the claim file at no cost to the Commission. All insurance carriers, Claims Administrators, or employers shall retain complete copies of claims files for the life of the Claim and a minimum of five (5) years from the date of closure. (3-23-22)

065. Filing Not an Admission. Filing a FROI is not an admission of liability and is not conclusive evidence of any fact stated therein. ~~If a Claim is submitted electronically, no signatures are required.~~ (3-23-22)(____)

076. Filing Considered Authorization. Filing of a Claim shall be considered an authorization for the release of medical records that are relevant to or bearing upon the particular injury or occupational disease for which the Claimant is seeking compensation. (3-23-22)

087. Timely Response Requirement. When the Commission requests additional information ~~in order~~ to process the Claim, the ~~Claimant or employer~~ surety or self-insured employer shall provide the requested information promptly within seven (7) days. The Commission's request may be ~~either~~ in writing or telephonic. (3-23-22)()

602. FINAL REPORTS.

01. Report Requirements. An electronic filing of the Final Report as prescribed by Commission EDI requirements shall be filed for all indemnity claims or any claims resolved by ~~lump sum~~ settlement agreement within thirty (30) days from the date the surety or self-insured employer closes the claim file. In the case of medical-only claims, no Final Report need be filed. For death claims and permanent total disability claims, Annual Reports shall be filed within the first quarter of each calendar year. A Final Report shall be filed within thirty (30) days from the date the surety or self-insured employer closes the death or permanent total disability claim file. In the event the Commission is unable to reconcile the Annual Report or Final Report, a written request for additional information may be made, ~~either in writing or telephonically~~, and the surety or self-insured employer shall submit the requested information within fifteen (15) working days of the request. If the surety or self-insured employer is unable to furnish the requested information, the surety or self-insured employer shall notify the Commission, in writing, of its inability to respond and the reasons therefor within fifteen (15) workings days of the request. (3-23-22)()

02. Format. The required format for Final Reports is contingent on the claim file date: (3-23-22)

a. Final Reports for legacy claims filed on paper or via EDI Claims 1.0 prior to November 4, 2017, shall be submitted in a format substantially similar to IC Form 6, available on the Commission's website, or EDI Claims Release 3.1 after September 14, 2023. (4-6-23)

b. Final Reports for legacy claims filed via EDI Claims 3.0 shall be submitted electronically via EDI Claims 3.0, or EDI Claims 3.1 after September 14, 2023. (4-6-23)

032. Change in Status of Employer. In case of any default by the Employer or in the event the Employer ~~shall~~ fails to pay any final award or awards, by reason of insolvency or because a receiver has been appointed, the receiver or successor shall continue to report to the Commission, including the submission of Annual Reports, Final Reports and schedules of outstanding awards. (3-23-22)()

603. -- 800. (RESERVED)

801. RULE GOVERNING CHANGE OF STATUS NOTICE TO CLAIMANTS.

01. Notice of Change of Status. ~~As required and defined by Section 72-806, Idaho Code~~ Pursuant to Section 72-806, Idaho Code, a worker shall receive written notice within fifteen (15) days of any change of status or condition, including, but not limited to, whenever there is an acceptance, commencement, denial, reduction, or cessation of medical or monetary compensation benefits to which the worker might presently or ultimately be entitled. Pursuant to Section 72-316, Idaho Code, ~~S~~such notice is required when benefits are curtailed to recoup any overpayment of benefits ~~in accordance with the provisions of Section 72-316, Idaho Code~~. (3-23-22)()

02. By Whom Given. ~~Any notice to a worker required by Section 72-806, Idaho Code, Notice of Change of Status~~ shall be given by: the surety if the employer has secured Worker's Compensation Insurance; or the employer if the employer is self-insured; or the employer if the employer carries no Worker's Compensation Insurance. (3-23-22)()

03. Form of Notice. ~~Any notice to a worker required by Section 72-806, Idaho Code, Notice of Change of Status~~ shall be mailed within ten (10) days by regular United States Mail to the last known address of the worker, as shown in the records of the party required to give notice as set forth above. If the worker has elected to receive electronic correspondence, notice may be emailed to the worker within fifteen (15) days. The Notice shall be given in

a format substantially similar to IC Form 8, available on the Commission's website. (3-23-22)()

~~04. **Medical Reports.** As required by Section 72-806, Idaho Code, if the change is based on a Medical Report, the party giving notice shall attach a copy of the report to the notice. (3-23-22)~~

~~054. **Copies of Notice.** The party giving notice pursuant to Section 72-806, Idaho Code, shall send a copy of any such notice to the Industrial Commission, the employer, and the worker's attorney, if the worker is represented, at the same time notice is sent to the worker. The party giving notice may supply the copy to the Industrial Commission in accordance with the Commission's rule on electronic submission of documents. The party will provide notice to the Commission consistent with its policy on electronic submission of the FROI and SROI. In the case of an overpayment recovery request made pursuant to I.C. 72-316, notice shall be contemporaneously submitted to the Commission by email or in paper format. (3-23-22)()~~

802. RULE GOVERNING APPROVAL OF ATTORNEYS FEES.

~~01. **Purpose.** The Industrial Commission promulgates this rule to govern the approval of attorney fees. (3-23-22)~~

~~021. **Charges Presumed Reasonable:** (3-23-22)~~

~~a. In a case in which no hearing on the merits has been held, twenty-five percent (25%) of Available Funds shall be presumed reasonable; or (3-23-22)~~

~~b. In a case in which a hearing has been held and briefs submitted (or waived) under Judicial Rules of Practice and Procedure (JRP), Rules X and XI, thirty percent (30%) of Available Funds shall be presumed reasonable; or (3-23-22)~~

~~c. In any case in which compensation is paid for total permanent disability, fifteen percent (15%) of such disability compensation after ten (10) years from date such total permanent disability payments commenced. (3-23-22)~~

~~032. **Statement of Charging Lien.** (3-23-22)~~

~~a. All requests for approval of fees shall be deemed requests for approval of a Charging Lien. (3-23-22)~~

~~b. An attorney representing a Claimant in a Worker's Compensation matter shall in any proposed LSS, within thirty (30) days of the Commission's dismissal of any Settlement Agreement or upon request of the Commission, file with the Commission, and serve the Claimant with a copy of the Fee Agreement, and an affidavit or memorandum containing: (3-23-22)()~~

~~i. The date upon which the attorney became involved in the matter; (3-23-22)~~

~~ii. Any issues which were undisputed at the time the attorney became involved; (3-23-22)~~

~~iii. The total dollar value of all compensation paid or admitted as owed by employer immediately prior to the attorney's involvement; (3-23-22)~~

~~iv. Disputed issues that arose subsequent to the date the attorney was hired; (3-23-22)~~

~~v. Counsel's itemization of compensation that constitutes Available Funds; (3-23-22)~~

~~vi. Counsel's itemization of costs and calculation of fees; and (3-23-22)~~

~~vii. The statement of the attorney identifying with reasonable detail his or her fulfillment of each element of the Charging Lien. (3-23-22)~~

c. Upon receipt and a determination of compliance with this Rule by the Commission by reference to its staff, the Commission may issue an Order Approving Fees without a hearing. The thirty (30) day-time period for counsel to submit the affidavit or memorandum may be waived for good cause shown. (3-23-22)()

04. Procedure if Fees Are Determined Not to Be Reasonable. (3-23-22)

a. Upon receipt of the affidavit or memorandum, ~~the Commission will designate staff members to determine reasonableness of the fee.~~ The Commission staff will notify counsel in writing of the staff's Commission's informal determination, which shall state the reasons for the determination that the requested fee is not reasonable. Omission of any information required by Paragraph 802.02.b. may constitute grounds for an informal determination that the fee requested is not reasonable. (3-23-22)()

b. If counsel disagrees with the Commission staff's informal determination, counsel may file, within fourteen (14) days of the date of the determination, a Request for Hearing for the purpose of presenting evidence and argument on the matter. Upon receipt of the Request for Hearing, the Commission shall schedule a hearing on the matter. A Request for Hearing shall be treated as a motion under Rule III(e), JRP. (3-23-22)

c. The Commission shall order an employer to release any Available Funds in excess of those subject to the requested Charging Lien and may order payment of fees subject to the Charging Lien which have been determined to be reasonable. (3-23-22)

d. The proponent of a fee which is greater than the percentage of recovery stated in Subsection 802.02 shall have the burden of establishing by clear and convincing evidence entitlement to the greater fee. The attorney shall always bear the burden of proving by a preponderance of the evidence his or her assertion of a Charging Lien and reasonableness of his or her fee. (3-23-22)

05. Disclosure Statement. Upon retention, the attorney shall provide to Claimant a copy of a disclosure statement. No fee may be taken from a Claimant by an attorney on a contingency fee basis unless the Claimant acknowledges receipt of the disclosure by signing it. Upon request by the Commission, an attorney shall provide a copy of the signed disclosure statement to the Commission. The terms of the disclosure may be contained in the Fee Agreement, so long as it contains the following text: (3-23-22)

a. In worker's compensation matters, attorney's fees normally do not exceed twenty-five percent (25%) of the benefits your attorney obtains for you in a case in which no hearing on the merits has been completed. In a case in which a hearing on the merits has been completed, attorney's fees normally do not exceed thirty percent (30%) of the benefits your attorney obtains for you. (3-23-22)

b. Depending upon the circumstances of your case, you and your attorney may agree to a higher or lower percentage which would be subject to Commission approval. Further, if you and your attorney have a dispute regarding attorney fees, either of you may petition the Industrial Commission, PO Box 83720, Boise, ID 83720-0041, to resolve the dispute. (3-23-22)

803. MEDICAL FEES.

01. General Provisions for Medical Fees. The following provisions shall apply to Commission approval of claims for medical benefits. (3-23-22)

a. Acceptable Charge. Payors shall pay Providers the acceptable charge for medical services. (3-23-22)

b. Coding. The Commission will generally follow the coding guidelines published by CMS and by the American Medical Association (AMA), including the use of modifiers and payment status indicators unless otherwise specified in Section 803 of this rule. (3-23-22)()

c. Disputes. Disputes between Providers and Payors are governed by Subsection 803.06 of this rule and JRP 19. (3-23-22)

d. Outside of Idaho. Reimbursement for medical services provided outside the state of Idaho may be based upon the agreement of the parties. If there is no agreement, services shall be paid in accordance with the worker's compensation fee schedule in effect in the state in which services are rendered. If there is no fee schedule in effect in such state, or if the fee schedule in that state does not allow reimbursement for the services rendered, reimbursement shall be paid in accordance with these rules. (3-23-22)

02. Acceptable Charges For Medical Services Provided By Physicians Under The Idaho Worker's Compensation Law. (3-23-22)

a. The Commission adopts the Resource-Based Relative Value Scale (RBRVS), published by CMS, as amended, as the standard to be used to determine acceptable charges by physicians. (3-23-22)

b. Modifiers. Modifiers for physicians will be reimbursed as follows: (3-23-22)

i. Modifier 50: Additional fifty percent (50%) for bilateral procedure. (3-23-22)

ii. Modifier 51: Fifty percent (50%) of secondary procedure. This modifier will be applied to each medical or surgical procedure rendered during the same session as the primary procedure. (3-23-22)

iii. Modifier 80: Twenty-five percent (25%) of coded procedure. (3-23-22)

iv. Modifier 81: Fifteen percent (15%) of coded procedure. This modifier applies to MD and non-MD assistants. (3-23-22)

c. Conversion Factors. The standard for determining the acceptable charge for a medical service, identified by a code assigned to that service in the latest edition of the Physician's CPT, published by the American Medical Association, as amended, is calculated by the application of the total facility or non-facility Relative Value Unit (RVU) for services as determined by place of service in the latest RBRVS in effect on the first day of January of the current calendar year, to the following corresponding conversion factors. The procedure with the largest RVU will be the primary procedure and will be listed first on the claim form. (3-23-22)()

MEDICAL FEE SCHEDULE			
SERVICE CATEGORY	CODE RANGE(S)	DESCRIPTION	CONVERSION FACTOR
Anesthesia	00000 - 09999	Anesthesia	\$60.33
Surgery - Group One	22000 - 22999	Spine	\$135.00
	23000 - 24999	Shoulder, Upper Arm, & Elbow	
	25000 - 27299	Forearm, Wrist, Hand, Pelvis & Hip	
	27300 - 27999	Leg, Knee, & Ankle	
	29800 - 29999	Endoscopy & Arthroscopy	
	61000 - 61999	Skull, Meninges & Brain	
	62000 - 62259	Repair, Neuroendoscopy & Shunts	
Surgery - Group Two	63000 - 63999	Spine & Spinal Cord	\$124.00
	28000 - 28999	Foot & Toes	
	64550 - 64999	Nerves & Nervous System	

MEDICAL FEE SCHEDULE			
SERVICE CATEGORY	CODE RANGE(S)	DESCRIPTION	CONVERSION FACTOR
Surgery - Group Three	10000 - 19999	Integumentary System	\$88.54
	20000 - 21999	Musculoskeletal System	
	29000 - 29799	Casts & Strapping	
	30000 - 39999	Respiratory & Cardiovascular	
	40000 - 49999	Digestive System	
	50000 - 59999	Urinary System	
	60000 - 60999	Endocrine System	
	62260 - 62999	Spine & Spinal Cord	
	64000 - 64549	Nerves & Nervous System	
	65000 - 69999	Eye & Ear	
Radiology	70000 - 79999	Radiology	\$88.54
Pathology & Laboratory	80000 - 89999	Pathology & Laboratory	To Be Determined
Medicine - Group One	90000 - 90749	Immunization, Injections, & Infusions	\$49.00
	94000 - 94999	Pulmonary / Pulse Oximetry	
	97000 - 97799	Physical Medicine & Rehabilitation	
	97800 - 98999	Acupuncture, Osteopathy, & Chiropractic	
Medicine - Group Two	90750 - 92999	Psychiatry & Medicine	\$70.00
	93000 - 93999	Cardiography, Catheterization, Vascular Studies	
	95000 - 96020	Allergy / Neuromuscular Procedures	
	96040 - 96999	Assessments & Special Procedures	
	99000 - 99607	E / M & Miscellaneous Services	

(3-23-22)

d. Anesthesiology. The Conversion Factor for the Anesthesiology CPT Codes shall be multiplied by the current Anesthesia Base Units assigned to that CPT Code by CMS, plus the allowable time units reported for the procedure. Time units are computed by dividing reported time by fifteen (15) minutes. Time units will not be used for CPT Code 01996. (3-23-22)

e. Services Without CPT Code, RVU or Conversion Factor. The acceptable charge for medical services that do not have a current CPT code, a currently assigned RVU, or a conversion factor will be the reasonable charge for that service, based upon the usual and customary charge and other relevant evidence, as determined by the Commission. Where a service with a CPT Code, RVU, and conversion factor is, nonetheless, claimed to be exceptional or unusual, the Commission may, notwithstanding the conversion factor for that service set out in Paragraph 02.c, above, determine the acceptable charge for that service, based on all relevant evidence in accordance with the procedures set out in Subsection 06, below. (3-23-22)

f. Medicine Dispensed by Physicians. Reimbursement to physicians for any medicine drug or topical agent, including over-the-counter (OTC), shall not exceed the lesser of the acceptable charge calculated for that medicine as if provided by a Pharmacy under Subsection 04 of this rule without a dispensing or compounding fee, or 130% of the AWP for the lowest-cost therapeutic equivalent drug. Reimbursement to physicians for repackaged medicine shall be lesser of the AWP for the medicine prior to repackaging, identified by the National Drug Code (NDC) reported by the original manufacturer, or 130% of the AWP for the lowest-cost therapeutic equivalent drug. Reimbursement may be withheld until the original manufacturer's NDC is provided by the physician. Physicians who dispense medications shall not receive a dispense or compounding fee. (3-23-22)()

g. Adjustment of Conversion Factors. The conversion factors set out in this rule may be adjusted each

fiscal year (FY) by the Commission to reflect changes in inflation or market conditions in accordance with Section 72-803, Idaho Code. (3-23-22)

03. Acceptable Charges For Medical Services Provided By Hospitals And Ambulatory Surgery Centers Under The Idaho Worker's Compensation Law. The following standards shall be used to determine the acceptable charge for Hospitals and ASCs. (3-23-22)

a. Critical Access Hospitals. The standard for determining the acceptable charge for inpatient and outpatient services provided by a Critical Access Hospital is ninety percent (90%) of the reasonable charge. Implantable hardware charges shall be reimbursed at the rate of the actual cost plus fifty percent (50%). (3-23-22)

b. Hospital Inpatient Services. The standard for determining the acceptable charge for inpatient services provided by Hospitals, other than Critical Access Hospitals, is calculated by multiplying the base rate by the current MS-DRG weight for that service. The base rate for inpatient services is ten thousand two hundred dollars (\$10,200). Inpatient services that do not have a relative weight shall be paid at eighty-five percent (85%) of the reasonable charge; however, Implantable Hardware charges billed for services without an MS-DRG weight shall be reimbursed at the rate of actual cost plus fifty percent (50%). (3-23-22)

c. Hospital Outpatient and ASC Services. The standard for determining the acceptable charge for outpatient services provided by Hospitals (other than Critical Access Hospitals) and for services provided by ASCs is calculated by multiplying the base rate by the Medicare Hospital Outpatient Prospective Payment System APC weight in effect on the first day of January of the current calendar year. The base rate for Hospital outpatient services is one hundred forty dollars and seventy-five cents (\$140.75). The base rate for ASC services is ninety-one dollars fifty cents (\$91.50). (3-23-22)

i. Medical services for which there is no APC weight listed shall be reimbursed at seventy-five percent (75%) of the reasonable charge, except when bundled with another service appearing on the same bill or is a service defined in 803.03.c.ii - iv of this rule. (3-23-22)()

ii. Status ~~code~~ indicator N items codes or items with no CPT or HCPCS code shall receive no payment except as provided in Subparagraph 803.03.c.ii.(1) or 803.03.c.ii.(2) of this rule. (3-23-22)()

iii. Outpatient physical, occupational, and speech therapy services will be reimbursed according to the allowable professional charge under subsection 803.02 of this rule. ()

iv. Status indicator Q codes are not subject to composite APC packaging standards. ()

(1) Implantable Hardware may be eligible for separate payment under Subparagraph 03.d.iii. of this rule. (3-23-22)

~~(2) Outpatient laboratory tests provided with no other Hospital outpatient service on the same date, or outpatient laboratory tests provided on the same date of service as other Hospital outpatient services that are clinically unrelated may be paid separately if billed with modifier L1. Payment shall be made in the same manner that services with no APC weight are paid under Subparagraph 803.03.c.i. of this rule.~~ (3-23-22)

~~iii. When no medical services with a status code J1 appears on the same Claim, two (2) or more medical procedures with a status code T on the same Claim shall be reimbursed with the highest weighted code paid at one hundred percent (100%) of the APC calculated amount and all other status code T items paid at fifty percent (50%). When a medical service with a status code J1 appears on the same Claim, all medical services with a status code T shall be paid at fifty percent (50%).~~ (3-23-22)

~~iv. When no medical services with a status code J1 appears on the same Claim, status code Q items with an assigned APC weight will not be discounted. When a medical service with a status code J1 appears on the same Claim, status code Q items shall be paid at fifty percent (50%).~~ (3-23-22)

d. Additional Hospital Payments. When the charge for a medical service provided by a Hospital (other than a Critical Access Hospital) meets the following standards, additional payment shall be made for that service, as

indicated. (3-23-22)

i. Inpatient Threshold Exceeded. When the charge for a Hospital inpatient MS-DRG coded service exceeds the sum of thirty thousand dollars (\$30,000) plus the payment calculated under the provisions of Paragraph 03.b. of this rule, then the total payment for that service shall be the sum of the MS-DRG payment and the amount charged above that threshold multiplied by seventy-five percent (75%). Implantable charges shall be excluded from the calculation for an additional inpatient payment under this Subparagraph. (3-23-22)

ii. Inpatient Implantable Hardware. Hospitals may seek additional reimbursement beyond the MS-DRG payment for invoiced Implantable Hardware where the aggregate invoice cost is greater than ten thousand dollars (\$10,000). Additional reimbursement shall be the invoice cost plus an amount which is equal to ten percent (10%) of the invoice cost, but which does not exceed three thousand dollars (\$3,000). Handling and freight charges shall be included in invoice cost. (3-23-22)

iii. Outpatient Implantable Hardware. Hospitals and ASCs may seek additional reimbursement beyond the APC payment for invoiced Implantable Hardware where the aggregate invoice cost is greater than five hundred dollars (\$500). Additional reimbursement shall be the invoice cost plus an amount which is equal to ten percent (10%) of the invoice cost, but which does not exceed one thousand dollars (\$1,000). Handling and freight charges shall be included in invoice cost. (3-23-22)

e. Adjustment of Hospital and ASC Base Rates. The Commission may periodically adjust the base rates set out in Paragraphs 803.03.b. and 803.03.c. of this rule to reflect changes in inflation or market conditions. (3-23-22)

04. Acceptable Charges For Medicine Provided By Pharmacies. The following standards shall be used to determine the acceptable charge for medicine provided by pharmacies. (3-23-22)

a. Brand/Trade Name Medicine. The standard for determining the acceptable charge for brand/trade name medicine shall be the AWP, plus a five dollar (\$5) dispensing fee. (3-23-22)

b. Generic Medicine. The standard for determining the acceptable charge for generic medicine shall be the AWP, plus an eight dollar (\$8) dispensing fee. (3-23-22)

c. Compound Medicine. The standard for determining the acceptable charge for compound medicine shall be the sum of the AWP for each drug included in the compound medicine, plus a five dollar (\$5) dispensing fee and a two dollar (\$2) compounding fee. All components of the compound medicine shall be identified by their original manufacturer's NDC when submitted for reimbursement. Payors may withhold reimbursement until the original manufacturer's NDC assigned to each component of the compound medicine is provided by the Pharmacy. Components of a compound medicine without an NDC may require medical necessity confirmation by the treating physician prior to reimbursement. (3-23-22)

d. Prescribed Over-the Counter Medicine. The standard for determining the acceptable charge for prescribed over-the-counter medicine filled by a Pharmacy shall be the reasonable charge plus a two dollar (\$2) dispensing fee. (3-23-22)

05. Acceptable Charges For Medical Services Provided By Other Providers Under The Idaho Worker's Compensation Law. The standard for determining the acceptable charge for Providers other than physicians, Hospitals or ASCs shall be the reasonable charge. (3-23-22)

a. Durable Medical Equipment (DME) Providers. Within the first thirty (30) days of equipment use, the Payor shall be given the option to rent or purchase DME. Rented equipment shall be considered purchased once the rental charges exceed the purchase price, which may not exceed ten percent (10%) of the invoice cost. If purchased, the DME shall become the property of the Claimant. ()

06. Billing And Payment Requirements For Medical Services And Procedures Preliminary To Dispute Resolution. This rule governs billing and payment requirements for medical services provided under the Worker's Compensation Law and the procedures for resolving disputes between Payors and Providers over those bills

or payments. (3-23-22)

a. Time Periods. None of the periods herein shall begin to run before the Notice of Injury/Claim for Benefits has been filed with the Employer as required by law. (3-23-22)

b. Provider to Furnish Information. A Provider, when submitting a bill to a Payor, shall inform the Payor of the nature and extent of medical services furnished and for which the bill is submitted. This information shall include, but is not limited to, the patient's name, the employer's name, the date the medical service was provided, the diagnosis, if any, and the amount of the charge or charges. ~~Failure to submit a bill complying with this Paragraph 06.b to the Payor within one hundred twenty (120) days of the date of service will result in the ineligibility of the Provider to utilize the dispute resolution procedures of the Commission set out in Paragraph 803.06.i. of this rule for that service. Except for the circumstances listed below, payment is forfeited when the charges are not billed within twelve (12) months from the date of service and may not be balance billed as defined in Idaho Code 72-102(2):~~ (3-23-22)()

(1) The industrial nature of the injury is initially unknown to the Provider; ()

(2) A change in Employer's coverage or designated claims administrator is unknown to the Provider. ()

(3) This list is not exhaustive, and the Commission has discretion to address disputes regarding timeliness of the billing in the dispute resolution procedures of the Commission set out in Paragraph 803.06.i of this rule. ()

i. A Provider's bill shall, whenever possible, describe the Medical Service provided, using the American Medical Association's appropriate CPT coding, including modifiers, the appropriate HCPCS code, the diagnostic and procedure code set version required by CMS and the original NDC for the year in which the service was performed. (3-23-22)

ii. The bill shall also contain the name, address and telephone number of the individual the Payor may contact in the event the Payor seeks additional information regarding the Provider's bill. (3-23-22)

iii. If requested by the Payor, the bill shall be accompanied by a written report as defined by Subsection 010.31 and required by Section 404 of these rules. Where a bill is not accompanied by such Report, the periods expressed in Paragraphs 803.06.c and 803.06.e. of this rule, shall not begin to run until the Payor receives the Report. (3-23-22)

c. Prompt Payment. Unless the Payor denies liability for the Claim or, pursuant to Paragraph 803.06.e. of this rule, sends a Preliminary Objection, a Request for Clarification, or both, as to any charge, the Payor shall pay the charge within thirty (30) calendar days of receipt of the bill or upon acceptance of liability, if made after bill is received from Provider. (3-23-22)

d. Partial Payment. If the Payor acknowledges liability for the Claim and, pursuant to Paragraph 803.06.e. of this rule, sends a Preliminary Objection, a Request for Clarification, or both, as to only part of a Provider's bill, the Payor must pay the charge or charges, or portion thereof, as to which no Preliminary Objection or Request for Clarification has been made, within thirty (30) calendar days of receipt of the bill. (3-23-22)

e. Preliminary Objections and Requests for Clarification. (3-23-22)

i. Whenever a Payor objects to all or any part of a Provider's bill on the ground that such bill contains a charge or charges that do not comport with the applicable administrative rule, the Payor shall send a written Preliminary Objection to the Provider within thirty (30) calendar days of the Payor's receipt of the bill explaining the basis for each of the Payor's objections. (3-23-22)

ii. Where the Payor requires additional information, the Payor shall send a written Request for Clarification to the Provider within thirty (30) calendar days of the Payor's receipt of the bill, and shall specifically describe the information sought. (3-23-22)

iii. Each Preliminary Objection and Request for Clarification shall contain the name, address, and phone number of the ~~individual~~ **Claims Administrator** located within the state of Idaho that the Provider may contact regarding the Preliminary Objection or Request for Clarification. (3-23-22)()

iv. Where a Payor does not send a Preliminary Objection to a charge set forth in a bill or a Request for Clarification within thirty (30) calendar days of receipt of the bill, or provide an in-state contact in accord with Subparagraph 06.e.iii., it shall be precluded from objecting to such charge as failing to comport with the applicable administrative rule. (3-23-22)

f. Provider Reply to Preliminary Objection or Request for Clarification. (3-23-22)

i. Where a Payor has timely sent a Preliminary Objection, Request for Clarification, or both, the Provider shall send to the Payor a written Reply, if any it has, within thirty (30) calendar days of the Provider's receipt of each Preliminary Objection or Request for Clarification. (3-23-22)

ii. If a Provider fails to timely reply to a Preliminary Objection, the Provider shall be deemed to have acquiesced in the Payor's objection. (3-23-22)

iii. If a Provider fails to timely reply to a Request for Clarification, the period in which the Payor shall pay or issue a Final Objection shall not begin to run until such clarification is received. (3-23-22)

g. Payor Shall Pay or Issue Final Objection. The Payor shall pay the Provider's bill in whole or in part or send to the Provider a written Final Objection, if any it has, to all or part of the bill within thirty (30) calendar days of the Payor's receipt of the Reply. (3-23-22)

h. Failure of Payor to Finally Object. Where the Payor does not timely send a Final Objection to any charge or portion thereof to which it continues to have an objection, it shall be precluded from further objecting to such charge as unacceptable. (3-23-22)

i. Dispute Resolution Process. If, after completing the applicable steps set forth above, a Payor and Provider are unable to agree on the appropriate charge for any Medical Service, a Provider which has complied with the applicable requirements of this rule may move the Commission to resolve the dispute as provided in the Judicial Rule Re: Disputes Between Providers and Payors, as referenced in Paragraph 803.01.c. of this rule. If Provider's motion disputing CPT or MS-DRG coded items prevails, Payor shall pay the amount found by the Commission to be owed, plus an additional thirty percent (30%) of that amount to compensate Provider for costs and expenses associated with using the dispute resolution process. For motions filed by a Provider disputing items without CPT or MS-DRG codes, the additional thirty percent (30%) shall be due only if the Payor does not pay the amount found due within thirty (30) days of the administrative order. (3-23-22)

804. – 999. (RESERVED)

IDAPA 20 – IDAHO DEPARTMENT OF LANDS
20.03.13 – ADMINISTRATION OF COTTAGE SITE LEASES ON STATE LANDS
DOCKET NO. 20-0313-2401 (ZBR CHAPTER REWRITE)
NOTICE OF RULEMAKING – ADOPTION OF PENDING RULE

EFFECTIVE DATE: This rule has been adopted by the agency and the Idaho State Board of Land Commissioners and is now pending review by the 2025 Idaho State Legislature and must be approved by concurrent resolution of the Legislature to go into effect, in accordance with Section 67-5224(2)(c), Idaho Code. Should the pending rule be approved, it will become final and effective on July 1, 2025, in the year of the First Regular Session of the Sixty-eighth Idaho Legislature, unless the concurrent resolution states a different effective date.

AUTHORITY: In compliance with Section 67-5224, Idaho Code, notice is hereby given that this agency has adopted a pending rule. The action is authorized pursuant to Sections 58-104(6) and 58-105, Idaho Code.

DESCRIPTIVE SUMMARY: The following is a concise explanatory statement of the reasons for adopting the pending rule and a statement of any change between the text of the proposed rule and the text of the pending rule with an explanation of the reasons for the change:

Following [Executive Order 2020-01, Zero-Based Regulation](#), this rule chapter is scheduled for a comprehensive review in 2024 with the goal of simplifying the rules for increased clarity and ease of use. The overall regulatory burden has been reduced by decreasing the total word count and number of restrictive words. The pending rule carries a 19.43 percent net reduction in word count, and a 50 percent net reduction in restrictive word count.

There are no changes to the pending rule, and it is being adopted as originally proposed. The complete text of the proposed rule was published in the July 3, 2024, Idaho Administrative Bulletin, [Vol. 24-7, pages 116-117](#).

FEE SUMMARY: Pursuant to Section 67-5224(2)(d), Idaho Code, a pending fee rule shall not become final and effective unless affirmatively approved by concurrent resolution of the Legislature. The following is a description of the fee or charge imposed or increased in this rulemaking: N/A

FISCAL IMPACT: The following is a specific description, if applicable, of any negative fiscal impact on the state general fund greater than ten thousand dollars (\$10,000) during the fiscal year: N/A

ASSISTANCE ON TECHNICAL QUESTIONS: For assistance on technical questions concerning this pending rule, contact Kemp Smith at 208-334-0202.

DATED this 20th day of August, 2024.

Kemp Smith, Commercial and Residential Program Manager
Idaho Department of Lands
300 N. 6th Street, Suite 103
P.O. Box 83720
Boise, Idaho 83702
Phone: 208-334-0202
Fax: 208-334-3698
rulemaking@idl.idaho.gov

IDAPA 20 – IDAHO DEPARTMENT OF LANDS

20.03.14 – RULES GOVERNING GRAZING, FARMING, AND CONSERVATION LEASES

DOCKET NO. 20-0314-2401 (ZBR CHAPTER REWRITE)

NOTICE OF RULEMAKING – ADOPTION OF PENDING RULE

EFFECTIVE DATE: This rule has been adopted by the agency and the Idaho State Board of Land Commissioners and is now pending review by the 2025 Idaho State Legislature and must be approved by concurrent resolution of the Legislature to go into effect, in accordance with Section 67-5224(2)(c), Idaho Code. Should the pending rule be approved, it will become final and effective on July 1, 2025, in the year of the First Regular Session of the Sixty-eighth Idaho Legislature, unless the concurrent resolution states a different effective date.

AUTHORITY: In compliance with Section 67-5224, Idaho Code, notice is hereby given that this agency has adopted a pending rule. The action is authorized pursuant to Section 58-104 of the Idaho Code.

DESCRIPTIVE SUMMARY: The following is a concise explanatory statement of the reasons for adopting the pending rule and a statement of any change between the text of the proposed rule and the text of the pending rule with an explanation of the reasons for the change:

Following [Executive Order 2020-01, Zero-Based Regulation](#), this rule chapter is scheduled for a comprehensive review in 2024 with the goal of simplifying the rules for increased clarity and ease of use. The overall regulatory burden has been reduced by decreasing the total word count and number of restrictive words. The pending rule carries a 10 percent net reduction in word count, and a 38 percent net reduction in restrictive word count.

There are no changes to the pending rule, and it is being adopted as originally proposed. The complete text of the proposed rule was published in the July 3rd, Idaho Administrative Bulletin, [Vol. 24-7, pages 118-129](#).

FEE SUMMARY: Pursuant to Section 67-5224(2)(d), Idaho Code, a pending fee rule shall not become final and effective unless affirmatively approved by concurrent resolution of the Legislature. The following is a description of the fee or charge imposed or increased in this rulemaking: N/A.

FISCAL IMPACT: The following is a specific description, if applicable, of any negative fiscal impact on the state general fund greater than ten thousand dollars (\$10,000) during the fiscal year: N/A.

ASSISTANCE ON TECHNICAL QUESTIONS: For assistance on technical questions concerning this pending rule, contact Addie Faust at (208) 334-0275.

DATED this 20th day of August, 2024.

Addie Faust, Natural Resource Leasing Program Manager
Idaho Department of Lands
300 N. 6th Street, Suite 103
P.O. Box 83720
Boise, Idaho 83702
Phone: (208) 334-0275
rulemaking@idl.idaho.gov

IDAPA 20 – IDAHO DEPARTMENT OF LANDS

20.03.15 – RULES GOVERNING GEOTHERMAL LEASING ON IDAHO STATE LANDS

DOCKET NO. 20-0315-2401 (ZBR CHAPTER REWRITE, FEE RULE)

NOTICE OF RULEMAKING – ADOPTION OF PENDING RULE

EFFECTIVE DATE: This rule has been adopted by the agency and the Idaho State Board of Land Commissioners and is now pending review by the 2025 Idaho State Legislature and must be approved by concurrent resolution of the Legislature to go into effect, in accordance with Section 67-5224(2)(c), Idaho Code. Should the pending rule be approved, it will become final and effective on July 1, 2025, in the year of the First Regular Session of the Sixty-eighth Idaho Legislature, unless the concurrent resolution states a different effective date.

AUTHORITY: In compliance with Section 67-5224, Idaho Code, notice is hereby given that this agency has adopted a pending rule. The action is authorized pursuant to Section 58-104(6) and 58-105, Idaho Code.

DESCRIPTIVE SUMMARY: The following is a concise explanatory statement of the reasons for adopting the pending rule and a statement of any change between the text of the proposed rule and the text of the pending rule with an explanation of the reasons for the change:

The Idaho Department of Lands initiated this rulemaking in compliance with [Executive Order 2020-01: Zero-Based Regulation](#) with the goal of simplifying and streamlining the rules for increased clarity and ease of use. There are no changes to the pending rule, and it is being adopted as originally proposed. The complete text of the proposed rule was published in the July 3, 2024, Idaho Administrative Bulletin, [Vol. 24-7, pages 130 -145](#).

FEE SUMMARY: Pursuant to Section 67-5224(2)(d), Idaho Code, this pending fee rule shall not become final and effective unless affirmatively approved by concurrent resolution of the Legislature. No changes have been made to any fees in this pending rule. The application fee (\$250) and assignment fee (\$150) remain the same. Rule language regarding late payment was removed to allow the Department to be consistent with statute as to how late fees are assessed.

FISCAL IMPACT: There is no negative fiscal impact on the state General Fund resulting from this rulemaking.

ASSISTANCE ON TECHNICAL QUESTIONS: For assistance on technical questions concerning this pending rule, contact Mike Murphy at (208-334-0290 or mmurphy@idl.idaho.gov).

DATED this 20th day of August, 2024.

Mike Murphy, Minerals Program Manager
Idaho Department of Lands
300 N. 6th Street, Suite 103
P.O. Box 83720 Boise, Idaho 83720-0050
Phone: (208)334-0290
Fax: (208)334-3698
rulemaking@idl.idaho.gov

IDAPA 20 – IDAHO DEPARTMENT OF LANDS

20.03.16 – RULES GOVERNING OIL AND GAS LEASING ON IDAHO STATE LANDS

DOCKET NO. 20-0316-2401 (ZBR CHAPTER REWRITE, FEE RULE)

NOTICE OF RULEMAKING – ADOPTION OF PENDING RULE

EFFECTIVE DATE: This rule has been adopted by the agency and the Idaho State Board of Land Commissioners and is now pending review by the 2025 Idaho State Legislature and must be approved by concurrent resolution of the Legislature to go into effect, in accordance with Section 67-5224(2)(c), Idaho Code. Should the pending rule be approved, it will become final and effective on July 1, 2025, in the year of the First Regular Session of the Sixty-eighth Idaho Legislature, unless the concurrent resolution states a different effective date.

AUTHORITY: In compliance with Section 67-5224, Idaho Code, notice is hereby given that this agency has adopted a pending rule. The action is authorized pursuant to Section 47-802, Idaho Code.

DESCRIPTIVE SUMMARY: The following is a concise explanatory statement of the reasons for adopting the pending rule and a statement of any change between the text of the proposed rule and the text of the pending rule with an explanation of the reasons for the change:

The Idaho Department of Lands initiated this rulemaking in compliance with [Executive Order 2020-01: Zero-Based Regulation](#) with the goal of simplifying and streamlining the rules for increased clarity and ease of use. There are no changes to the pending rule, and it is being adopted as originally proposed. The complete text of the proposed rule was published in the July 3, 2024 Idaho Administrative Bulletin, [Vol. 24-7, pages 146 – 161](#).

FEE SUMMARY: Pursuant to Section 67-5224(2)(d), Idaho Code, this pending fee rule shall not become final and effective unless affirmatively approved by concurrent resolution of the Legislature. No changes have been made to any fees in this pending rule. The exploration permit fee remains \$100 per linear mile or a minimum of \$100 per section. Nomination fees continue to be set by the State Board of Land Commissioners (Land Board), at a minimum of \$250 per tract. Processing fees continue to be set by the Land Board at a minimum of \$100 per each document.

FISCAL IMPACT: There is no negative fiscal impact on the state General Fund resulting from this rulemaking.

ASSISTANCE ON TECHNICAL QUESTIONS: For assistance on technical questions concerning this pending rule, contact Mike Murphy at (208) 334-0290 or at mmurphy@idl.idaho.gov.

DATED this 20th day of August, 2024.

Mike Murphy, Minerals Program Manager
Idaho Department of Lands
300 N. 6th Street, Suite 103
P.O. Box 83720 Boise, Idaho 83720-0050
Phone: (208)334-0290
Fax: (208)334-3698
rulemaking@idl.idaho.gov

IDAPA 24 – DIVISION OF OCCUPATIONAL AND PROFESSIONAL LICENSES

24.03.01 – RULES OF THE STATE BOARD OF CHIROPRACTIC PHYSICIANS

DOCKET NO. 24-0301-2401 (ZBR CHAPTER REWRITE)

NOTICE OF RULEMAKING – ADOPTION OF PENDING RULE

EFFECTIVE DATE: This rule has been adopted by the agency and is now pending review by the 2025 Idaho State Legislature and must be approved by concurrent resolution of the Legislature to go into effect, in accordance with Section 67-5224(2)(c), Idaho Code. Should the pending rule be approved, it will become final and effective on July 1, 2025, in the year of the First Regular Session of the Sixty-eighth Idaho Legislature, unless the concurrent resolution states a different effective date.

AUTHORITY: In compliance with Section 67-5224, Idaho Code, notice is hereby given that this agency has adopted a pending rule. The action is authorized pursuant to Section 67-2604, Idaho Code, Sections 67-9404, 67-9405, 67-9406, 67-9409, and 67-9413, Idaho Code, and Sections 54-701 through 54-717, Idaho Code.

DESCRIPTIVE SUMMARY: The following is a concise explanatory statement of the reasons for adopting the pending rule and a statement of any change between the text of the proposed rule and the text of the pending rule with an explanation of the reasons for the change:

The pending rule is being adopted under [Executive Order 2020-01, Zero Based Regulation](#). Text amended since these rules were published as proposed are purely administrative in nature. No substantive changes are made. The change can be found in Appendix A, Section 2 where the reference to Rule 450 was removed as it no longer exists.

The text of the pending rule has been amended in accordance with Section 67-5227, Idaho Code. Only those sections that have changes that differ from the proposed text are printed in this bulletin. The complete text of the proposed rule was published in the July 3, 2024 Idaho Administrative Bulletin, [Vol. 24-7, pages 187-204](#).

FEE SUMMARY: Pursuant to Section 67-5224(2)(d), Idaho Code, a pending fee rule shall not become final and effective unless affirmatively approved by concurrent resolution of the Legislature. The following is a description of the fee or charge imposed or increased in this rulemaking:

As authorized in Section 54-707A, Idaho Code, the fee(s) in this rulemaking are established in Rule 400. None of these fees are being changed as a result of this rulemaking or since being previously reviewed by the Idaho Legislature.

FISCAL IMPACT: The following is a specific description, if applicable, of any negative fiscal impact on the state general fund greater than ten thousand dollars (\$10,000) during the fiscal year:

This rulemaking is not anticipated to have any negative fiscal impact on the State General Fund.

ASSISTANCE ON TECHNICAL QUESTIONS: For assistance on technical questions concerning this pending rule, contact Krissy Veseth, Bureau Chief, at (208) 577-2491. Materials pertaining to the pending rulemaking, including any available preliminary rule drafts, can be found on the following DOPL website: <https://dopl.idaho.gov/rulemaking/>.

DATED this 30th day of August, 2024.

Krissy Veseth
Bureau Chief
11341 W. Chinden Blvd., Bldg. #4
Boise, ID 83714
Phone: (208) 577-2491
Email: krissy.veseth@dopl.idaho.gov

DOCKET NO. 24-0301-2401 - ADOPTION OF PENDING RULE

Substantive changes have been made in the pending rule.
Italicized text indicates amendments to the proposed text as adopted in the pending rule.

The text of the proposed rule was published in the Idaho Administrative Bulletin,
Volume 24-7, July 3, 2024, pages 187 through 204.

This rule has been adopted as a pending rule by the Agency and is now awaiting
review and final approval by the 2025 Idaho State Legislature.

THE FOLLOWING IS THE TEXT OF THE PENDING RULE FOR DOCKET NO. 24-0301-2401
(Only those sections or subsections that have changed from the original proposed
text are printed in this Bulletin following this notice.)

24.03.01 – RULES OF THE STATE BOARD OF CHIROPRACTIC PHYSICIANS

~~740~~**03.** -- 999. (RESERVED)

Appendix A – Chiropractic Physicians Code of Ethics

PREAMBLE

This code of ethics sets forth principles for the ethical practice of chiropractic. All chiropractic physicians are responsible for maintaining and promoting ethical practice and otherwise complying with the terms of this code of ethics. To this end, the chiropractic physician must act in the best interest of the patient. This code of ethics is binding on all chiropractic physicians.

1. Duty to Report

A. It is the duty of every licensee to notify the Board through the Division of Occupational and Professional Licenses of any violation of the Chiropractic Act or Board Rules, if the licensee has personal knowledge of the conduct.

B. If a judgment is entered against a licensee in any court, or a settlement is reached on a claim involving malpractice exceeding fifty thousand dollars (\$50,000), a licensee must report that fact to the Board within thirty (30) days. The licensee may satisfy the provision of this subsection if he/she provides the Board with a copy of the judgment or settlement.

~~C.~~ If convicted of a felony or a crime involving dishonesty, theft, violence, habitual use of drugs or alcohol, or sexual misconduct, the licensee must report that fact to the board within thirty (30) days following the conviction.

2. Advertising of Research Projects

~~Advertisement of Affiliation with Research Projects.~~ If a licensee advertises any affiliation with a research project, he must make a written statement of the objectives, cost and budget of the project, and the person conducting the research. Such statements are to be made available at the request of the Board, to scientific organizations, and to the general public. The advertisement must indicate that it is ~~supported by~~ **for the purpose of** clinical research. Any

willful failure to comply with these requirements will be deemed false and deceptive advertising ~~under rule 450~~. Licensees must comply with all state and federal laws and regulations governing research projects on humans, and will obtain “Institutional Review Board” (IRB) approval as established and set forth in the U.S. Code of Federal Regulations, Title 45, Part 46, Subpart A (45 CFR 46.101-46-505).

3. Sexual Misconduct

The doctor-patient relationship requires the chiropractic physician to exercise utmost care that he or she will do nothing to exploit the trust and dependency of the patient. Sexual misconduct is a form of behavior that adversely affects the public welfare and harms patients individually and collectively. Sexual misconduct exploits the doctor-patient relationship and is a violation of the public trust. ~~This section of the Code of Ethics shall not apply between a chiropractor and their spouse~~ A chiropractic physician shall wait at least one (1) year (“waiting period”) following the termination of a professional doctor-patient relationship, before beginning any type of sexual relationship with a former patient.

For the purposes of this subsection, sexual misconduct is divided into sub-categories based upon the severity of the conduct:

A. Sexual Impropriety. Any behavior such as gestures, expressions, and statements which are sexually suggestive or demeaning to a patient, or which demonstrate a lack of respect for a patient's privacy.

B. Sexual Violation. Physician-patient contact of a sexual nature, whether initiated by the physician or the patient.

~~C. A chiropractic physician shall wait at least one (1) year (“waiting period”) following the termination of a professional doctor-patient relationship, before beginning any type of sexual relationship with a former patient.~~

4. Prepaid Funds

A chiropractic physician shall promptly refund any unearned fees within thirty (30) days upon request and cancellation of the prepaid contract. A full accounting of the patient account shall be provided to the patient at the time of the refund or upon request.

IDAPA 24 – DIVISION OF OCCUPATIONAL AND PROFESSIONAL LICENSES
24.04.01 – RULES OF THE BOARD OF REGISTRATION FOR PROFESSIONAL GEOLOGISTS
DOCKET NO. 24-0401-2401 (ZBR CHAPTER REWRITE, FEE RULE)
NOTICE OF RULEMAKING – PROPOSED RULE

AUTHORITY: In compliance with Section 67-5221(1), Idaho Code, notice is hereby given that this agency has initiated proposed rulemaking procedures. This rulemaking action is authorized pursuant to Section 67-2604, Idaho Code, Sections 67-9404, 67-9405, 67- 9406, 67-9409, and 67-9413, Idaho Code, and 54-2801 through 54-2822, Idaho Code.

PUBLIC HEARING SCHEDULE: The public hearing concerning this rulemaking will be held as follows:

24.04.01 – Rules of the Board of Registration for Professional Geologists
Thursday, October 17, 2024 – 9 a.m. (MT) Division of Occupational and Professional Licenses EagleRock Room, Chinden Campus Building 4 11341 W. Chinden Blvd. Boise, ID 83714
Virtual Meeting Link
Telephone and web conferencing information will be posted on https://dopl.idaho.gov/calendar/ and https://townhall.idaho.gov/ .

The hearing site will be accessible to persons with disabilities, if needed. Requests for accommodation must be made not later than five (5) days prior to the meeting to the agency address below.

DESCRIPTIVE SUMMARY AND STATEMENT OF PURPOSE: The following is a nontechnical explanation of the substance and purpose of the proposed rulemaking:

Under [Executive Order 2020-01, Zero-Based Regulation](#), the Idaho Board of Professional Geologists is striving to prevent the accumulation of costly, ineffective, and outdated regulations and reduce regulatory burden to achieve a more efficient operation of government. In conjunction with stakeholders, the proposed rule changes reflect a comprehensive review of this chapter by collaborating with the public to streamline or simplify the rule language in this chapter and to use plain language for better understanding. This proposed rulemaking updates the rules to comply with governing statute and Executive Order 2020-01.

FEE SUMMARY: The following is a specific description of the fee or charge imposed or increased:

This proposed rulemaking increases the annual renewal fee from \$60 to \$100.

FISCAL IMPACT: The following is a specific description, if applicable, of any negative fiscal impact on the state General Fund greater than ten thousand dollars (\$10,000) during the fiscal year as a result of this rulemaking:

This rulemaking is not anticipated to have any negative fiscal impact on the state General Fund.

NEGOTIATED RULEMAKING: Pursuant to Section 67-5220, Idaho Code, negotiated rulemaking was conducted under Docket No. 24-0401-2401. Notice of Intent to Promulgate Rules - Negotiated Rulemaking was published in the June 5, 2024, Idaho Administrative Bulletin, [Vol. 24-6, p.70-71](#).

INCORPORATION BY REFERENCE: Pursuant to Section 67-5229(2)(a), Idaho Code, the following is a brief synopsis of why the materials cited are being incorporated by reference into this rule:

N/A. No materials have been incorporated by reference into the proposed rules.

ASSISTANCE ON TECHNICAL QUESTIONS, SUBMISSION OF WRITTEN COMMENTS, OBTAINING DRAFT COPIES: For assistance on technical questions concerning this proposed rule, contact Krissy Veseth, Bureau Chief, at (208) 577-2491. Materials pertaining to the proposed rulemaking, including any available preliminary rule drafts, can be found on the following DOPL website: <https://dopl.idaho.gov/rulemaking/>.

Anyone may submit written comments regarding this proposed rulemaking. All written comments must be directed to the undersigned and must be delivered on or before October 23, 2024.

DATED this 30th day of August, 2024.

Krissy Veseth
Bureau Chief
11341 W. Chinden Blvd., Bldg. #4
Boise, ID 83714
Phone: (208) 577-2491
Email: krissy.veseth@dopl.idaho.gov

THE FOLLOWING IS THE PROPOSED TEXT OF DOCKET NO. 24-0401-2401
(ZBR Chapter Rewrite)

24.04.01 – RULES OF THE BOARD OF REGISTRATION FOR PROFESSIONAL GEOLOGISTS

000. LEGAL AUTHORITY.

These rules are promulgated pursuant to Sections 54-2808, ~~67-2604, 67-2614, 67-9409, and 67-9406~~, Idaho Code. ~~(3-28-23)~~()

001. SCOPE.

These rules govern the practice of geology in Idaho. (3-28-23)

~~002. 009.~~ **(RESERVED)**

~~010~~**02. DEFINITIONS.**

~~For the purposes of these rules, the following definitions apply:~~ ~~(3-28-23)~~

01. Geologist-in-Training. ~~The interim designation given to any person who has met the academic requirements and successfully passed the fundamentals of geology portion of the professional examination but has not yet completed the requisite years of experience and passed the practices of geology examination.~~ An individual who has met the academic qualifications established by the Board, who has successfully passed a written examination demonstrating knowledge of the Fundamentals of Geology, and who has been enrolled as a Geologist-in-Training by the Board. ~~(3-28-23)~~()

~~02. Registrant.~~ Any person currently registered as a professional geologist. (3-28-23)

~~03.~~ **Responsible Position.** A position ~~wherein~~ in which a person, ~~having~~ has independent control,

direction, or supervision of a geological project, and who investigates and interprets geologic features. (3-28-23)()

043. Responsible Charge. ~~Means the e~~ Control and direction of geology work, requiring initiative, professional skill, independent judgment, and professional knowledge of the content of relevant documents during their preparation. (3-28-23)()

~~043.~~ -- 099. (RESERVED)

100. LICENSURE.

01. Examination. ~~Except as otherwise provided in statute, every Applicant for registration as a professional geologist shall take and pass the ASBOG Fundamentals of Geology and Practice of Geology Examinations. Applicants who have completed the educational requirements of Section 54-2812, Idaho Code, may be eligible to take the Fundamentals of Geology examination prior to graduation.~~ ()

a. Authorization. ()

i. ~~Not less than ninety (90) days prior to the examination date, the Applicant shall give written notice to the Board of the applicant's intent to take the examination. Not less than thirty (30) days prior to the examination date, the Board shall notify each Applicant in writing of the acceptance or rejection of the application, and, if rejected by the Board, the reason for the rejection.~~ ()

b. Reexamination. ~~An Applicant failing their first examination may apply for reexamination without filing a new Application and shall be entitled to such reexamination on payment of the reexamination fee.~~ ()

c. Scores. ~~An Applicant for registration by examination must successfully pass both the Fundamentals of Geology examination and the Practice of Geology examination. The passing score is determined by ASBOG. An Applicant who has passed only the Fundamentals of Geology examination is eligible to receive a certificate as a Geologist-in-Training. An Applicant who has passed the Practice of Geology examination is eligible to apply for registration as a professional geologist.~~ ()

02. Geologist-In-Training. ~~An Applicant who has passed the Fundamentals of Geology examination will receive a certificate of completion designating the Applicant as a Geologist-in-Training. A Geologist-in-Training shall not practice without supervision. Certification as a Geologist-in-Training is limited to ten (10) years.~~ ()

~~101. -- 199.~~ (RESERVED)

~~100~~**200. GENERAL PROVISIONS PRACTICE STANDARDS.**

01. Certificates. Certificates of registration are issued to each Registrant on forms adopted by the Board. ~~Certificates must be displayed by Registrants in their place of business~~ (3-28-23)()

02. Seals. ~~The Board has adopted a seal for use by each Registrant. Whenever the seal is applied, t~~ The Registrant's signature and date are also included. A signature may be a handwritten or digital signature. If the signature is handwritten, it will be adjacent to or across the seal. No further words or wording are required. ~~A facsimile signature generated by any method will not be acceptable unless accompanied by a digital signature.~~ (See "Appendix A" at end of this Chapter.) (3-28-23)()

a. The seal, signature, and date must be placed on all final specifications, reports, information, and calculations, ~~whenever presented. Any such~~ A document that is not final and does not contain a seal, signature, and date will be clearly marked as "Preliminary," "Draft," or "Not for Construction," ~~or with similar words to distinguish the document from a final document.~~ (3-28-23)()

b. The seal, signature, and date must be placed on all original documents. The application of the Registrant's seal, signature, and date constitutes certification that the work ~~thereon~~ was done by the Registrant or under the Registrant's supervision. Each plan or drawing sheet is sealed and signed by the Registrant or Registrants

responsible for each sheet. In the case of a business entity, each plan or drawing sheet is sealed and signed by the Registrant or Registrants involved. The supervising professional geologist signs and seals the title or first sheet. ~~Copies of electronically produced documents, listed in Paragraph 100.06.b. of these rules, distributed for informational uses such as for bidding purposes or working copies, may be issued with the Registrant's seal and a notice that the original document is on file with the Registrant's signature and date. The words "Original Signed By:" and "Date Original Signed:" are placed adjacent to or across the seal on the electronic original. The storage location of the original document must also be provided.~~ Only the title page of reports, specifications, and like documents need bear the seal, signature, and date ~~of the Registrant.~~ (3-28-23)()

~~e. The seal and signature may be used by the Registrant only when the work being stamped was under the Registrant's responsible charge. Upon sealing, the Registrant takes full professional responsibility for that work. After the fact ratification by the sealing of documents relating to work that was not performed by the Registrant but by an unregistered subordinate or other unregistered individual and without thorough technical review throughout the project by the sealing Registrant is prohibited.~~ (3-28-23)

~~d.c. In the event a Registrant in responsible charge of a project leaves employment, is transferred, is promoted, becomes incapacitated, dies, or is otherwise is not available to seal, sign, and date final documents, the duty of responsible charge for the project is accomplished by successor Registrant by becoming familiar with and reviewing, in detail, and retaining the project documents to date. Subsequent work on the project must clearly and accurately reflect the successor Registrant's responsible charge. The successor Registrant must seal, sign, and date all work product in conformance with Section 54-2815, Idaho Code.~~ (3-28-23)()

~~03. Address Change. Each Applicant and Registrant must notify the Board within sixty (60) days of any and all changes of address, giving both old and new address.~~ (3-28-23)

~~101-201. -- 149399.(RESERVED)~~

~~150-400. FEES.~~

FEE TYPE	AMOUNT (Not to Exceed)
Application	\$100
Initial Certificate	\$20
Annual Renewal	\$60 100
Annual Renewal for Registrants Seventy (70) Years of Age or Older	One-half (1/2) of the current renewal fee
Reinstatement	Is as provided in Section 67-2614, \$200, pursuant to Section 54-2816, Idaho Code
Duplicate Certificate	\$20
Examination-	Set by ASBOG

(3-28-23)()

~~151. — 199. (RESERVED)~~

~~200. APPLICATION PROCEDURES.~~

~~01. Applications. Applications for registration must be:~~ (3-28-23)

~~a. On forms prescribed by the Board and accompanied by official transcripts, reference statements, and a signed code of ethics;~~ (3-28-23)

~~b. Received by the Board, if for registration by examination, not less than ninety (90) days prior to the date of examination; (3-28-23)~~

~~and c. Subscribed and certified to by the Applicant under penalty of perjury as provided for by state law; (3-28-23)~~

~~d. Incomplete applications will not be accepted by the Board and will be returned to the Applicant with a statement of the reason for return. (3-28-23)~~

~~02. **Dates.** The date of application is the date it is delivered in person to the Board office or, if mailed, the date shown by post office cancellation mark. Qualifying education and experience of the Applicant, for examination and registration, is computed from the date of application as described above. (3-28-23)~~

~~03. **References.** Statements from personal references in Responsible Positions concerning the Applicant's technical ability and personal character, will be received, as prescribed by the Act, prior to any action by the Board to approve an Application. Each statement must reflect in a positive way the technical and ethical merits of the Applicant. Applicants for the Fundamentals of Geology examination may fulfill this requirement with reference statements from geologists in Responsible Positions familiar with the ability and character of the Applicant as demonstrated in an academic setting. (3-28-23)~~

~~04. **Lack of Activity.** If an applicant fails to respond to a Board request or an application has lacked activity for twelve (12) consecutive months, the application on file with the Board will be deemed denied and will be terminated upon a thirty (30) day written notice, unless good cause is demonstrated to the Board. (3-28-23)~~

~~201.—299. (RESERVED)~~

300. EXAMINATIONS.

~~Except as otherwise provided in statute, every Applicant for registration as a professional geologist shall take and pass the complete professional examination for registration as a professional geologist. (3-28-23)~~

~~01. **Fundamentals of Geology.** The written examination is the Fundamentals of Geology examination provided by ASBOG. To be eligible to take the Fundamentals of Geology examination, an Applicant must have completed thirty (30) semester units or equivalent quarter units in courses in geological science leading to a degree in the geological sciences of which at least twenty-four (24) units are in third or fourth year, and/or graduate courses. Applicants who can satisfy to the Board that they will have completed the required coursework and number of units and will be graduating at the end of the spring, summer or fall terms of any given year, may be eligible for examination immediately preceding the date of graduation. (3-28-23)~~

~~02. **Practice of Geology.** The written examination is the Practice of Geology examination provided by ASBOG. To be eligible to take the Practice of Geology examination an Applicant must have satisfied the education requirements as set forth in Section 54-2812, Idaho Code. (3-28-23)~~

~~03. **Authorization.** (3-28-23)~~

~~a. The Board shall notify each Applicant in writing of the acceptance or rejection of his Application and, if rejected, the reason for the rejection. (3-28-23)~~

~~b. Not less than ninety (90) days prior to the examination date, the Applicant shall give written notice to the Board of his intent to take the examination and shall submit all applicable testing fees in full. (3-28-23)~~

~~e. Not less than thirty (30) days prior to the examination date, the Board shall give written notice to each Applicant that has previously given written notice and has paid his examination fees, of the date, time, and location(s) of the examination. (3-28-23)~~

~~04. **Retesting.** An Applicant failing their first examination may apply for retesting without filing a new Application and shall be entitled to such retesting on payment of the retesting fee. Provided, however, that it shall be unlawful for an Applicant failing any examination to practice professional geology under the~~

~~appropriate provisions of the Act. (3-28-23)~~

~~**05. Time and Place.** The Board shall make all arrangements necessary to provide sufficient help to conduct examinations and to provide adequate facilities at such locations throughout the state as may be required to accommodate the number of Applicants to be examined upon the dates prescribed by ASBOG. (3-28-23)~~

~~**06. Scores.** An Applicant for registration by examination must successfully pass both the Fundamentals of Geology examination and the Practice of Geology examination. (3-28-23)~~

~~**a.** Every Applicant receiving a scaled score of seventy (70) or more, as determined by ASBOG, on the Fundamentals of Geology examination shall be deemed to have passed the examination, is thereby eligible to receive certification as a Geologist in Training. (3-28-23)~~

~~**b.** Every Applicant receiving a scaled score of seventy (70) or more, as determined by ASBOG, on the Practice of Geology examination shall be deemed to have passed such examination and will be registered as a professional geologist. (3-28-23)~~

~~**e.** Every Applicant receiving a scaled score of less than seventy (70), as determined by ASBOG, on either the Fundamentals of Geology examination or the Practice of Geology examination, is deemed to have failed such examination. Every Applicant having failed will have his Application denied without prejudice, but will be allowed to retake the failed examination in accordance with Subsection 300.04 of these rules. (3-28-23)~~

~~**07. Re Score or Review of Examination.** (3-28-23)~~

~~**a.** An Applicant who fails to obtain a passing grade in any portion of the written examination may request a rescore or review of his examination papers at such times, locations, and under such circumstances as may be designated by the Board, ASBOG, or both. (3-28-23)~~

~~**b.** When a review is requested and authorized, at the time of review, no one other than the examinee or his attorney and a representative of the Board will have access to such examination papers. (3-28-23)~~

~~**301. -- 399. (RESERVED)**~~

~~**400. GEOLOGIST IN TRAINING.**~~

~~An Applicant who has passed the Fundamentals of Geology examination and satisfied the education requirements set forth in Subsection 300.01 of these rules, will receive a certificate of completion designating the Applicant as a Geologist in Training. (3-28-23)~~

~~**01. Supervised Practice.** The possession of a Geologist in Training certificate by an Applicant does not entitle the Applicant to practice professional geology without supervision. (3-28-23)~~

~~**02. Limitation.** Designation as a Geologist in Training is limited to a period not to exceed ten (10) years. If after ten (10) years the Geologist in Training has not met all requirements for registration as a professional geologist, the Geologist in Training certification is withdrawn and the Applicant must re-apply for registration. (3-28-23)~~

~~**401. -- 999. (RESERVED)**~~

~~APPENDIX A -- AS REFERENCED IN SECTION 24.04.01.100.06.b.~~

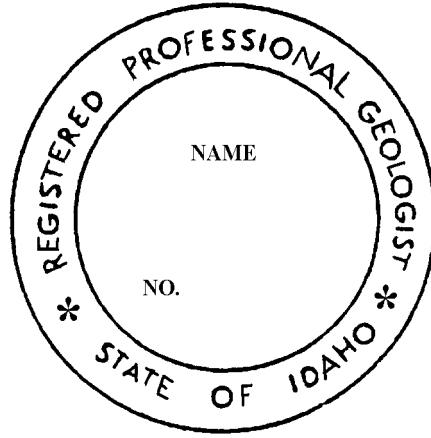

SEAL OF REGISTERED PROFESSIONAL GEOLOGIST
Diameter of Outer Ring: 1 1/2 Inches
Diameter of Inner Ring: 1 Inch

IDAPA 24 – DIVISION OF OCCUPATIONAL AND PROFESSIONAL LICENSES
24.09.01 – RULES OF THE BOARD OF EXAMINERS OF NURSING HOME ADMINISTRATORS
DOCKET NO. 24-0901-2401 (ZBR CHAPTER REWRITE)
NOTICE OF RULEMAKING – ADOPTION OF PENDING RULE

EFFECTIVE DATE: This rule has been adopted by the agency and is now pending review by the 2025 Idaho State Legislature and must be approved by concurrent resolution of the Legislature to go into effect, in accordance with Section 67-5224(2)(c), Idaho Code. Should the pending rule be approved, it will become final and effective on July 1, 2025, in the year of the First Regular Session of the Sixty-eighth Idaho Legislature, unless the concurrent resolution states a different effective date.

AUTHORITY: In compliance with Section 67-5224, Idaho Code, notice is hereby given that this agency has adopted a pending rule. The action is authorized pursuant to Section 67-2604, Idaho Code, Sections 67-9404, 67-9405, 67-9406, 67-9409, and 67-9413, Idaho Code, and Sections 54-1601 through 54-1616, Idaho Code.

DESCRIPTIVE SUMMARY: The following is a concise explanatory statement of the reasons for adopting the pending rule and a statement of any change between the text of the proposed rule and the text of the pending rule with an explanation of the reasons for the change:

Under [Executive Order 2020-01, Zero-Based Regulation](#), the Idaho Board of Examiners of Nursing Home Administrators is striving to prevent the accumulation of costly, ineffective, and outdated regulations and reduce regulatory burden to achieve a more efficient operation of government. There are no changes to the pending rule, and it is being adopted as originally proposed. The complete text of the proposed rule was published in the July 3, 2024, Idaho Administrative Bulletin, [Vol. 24-7, pages 205-210](#).

FEE SUMMARY: Pursuant to Section 67-5224(2)(d), Idaho Code, a pending fee rule shall not become final and effective unless affirmatively approved by concurrent resolution of the Legislature. The following is a description of the fee or charge imposed or increased in this rulemaking:

As authorized in Section 54-1604, Idaho Code, the fee(s) in this rulemaking are established in Rule 600. None of these fees are being changed as a result of this rulemaking or since being previously reviewed by the Idaho Legislature.

FISCAL IMPACT: The following is a specific description, if applicable, of any negative fiscal impact on the state General Fund greater than ten thousand dollars (\$10,000) during the fiscal year:

This rulemaking is not anticipated to have any negative fiscal impact on the state General Fund.

ASSISTANCE ON TECHNICAL QUESTIONS: For assistance on technical questions concerning this pending rule, contact Krissy Veseth, Bureau Chief, at (208) 577-2491. Materials pertaining to the pending rulemaking, including any available preliminary rule drafts, can be found on the following DOPL website: <https://dopl.idaho.gov/rulemaking/>.

DATED this 30th day of August, 2024.

Krissy Veseth
Bureau Chief
11341 W. Chinden Blvd., Bldg. #4
Boise, ID 83714
Phone: (208) 577-2491
Email: krissy.veseth@dopl.idaho.gov

IDAPA 24 – DIVISION OF OCCUPATIONAL AND PROFESSIONAL LICENSES

24.19.01 – RULES OF THE BOARD OF EXAMINERS OF RESIDENTIAL CARE FACILITY ADMINISTRATORS

DOCKET NO. 24-1901-2401 (ZBR CHAPTER REWRITE, FEE RULE)

NOTICE OF RULEMAKING – ADOPTION OF PENDING RULE

EFFECTIVE DATE: This rule has been adopted by the agency and is now pending review by the 2025 Idaho State Legislature and must be approved by concurrent resolution of the Legislature to go into effect, in accordance with Section 67-5224(2)(c), Idaho Code. Should the pending rule be approved, it will become final and effective on July 1, 2025, in the year of the First Regular Session of the Sixty-eighth Idaho Legislature, unless the concurrent resolution states a different effective date.

AUTHORITY: In compliance with Section 67-5224, Idaho Code, notice is hereby given that this agency has adopted a pending rule. The action is authorized pursuant to Section 67-2604, Idaho Code, Sections 67-9404, 67-9405, 67-9406, 67-9409, and 67-9413, Idaho Code, and Sections 54-4201 through 54-4216, Idaho Code.

DESCRIPTIVE SUMMARY: The following is a concise explanatory statement of the reasons for adopting the pending rule and a statement of any change between the text of the proposed rule and the text of the pending rule with an explanation of the reasons for the change:

Under [Executive Order 2020-01, Zero-Based Regulation](#), the Idaho Board of Examiners of Residential Care Facility Administrators is striving to prevent the accumulation of costly, ineffective, and outdated regulations and reduce regulatory burden to achieve a more efficient operation of government. There are no changes to the pending rule, and it is being adopted as originally proposed. The complete text of the proposed rule was published in the July 3, 2024, Idaho Administrative Bulletin, [Vol. 24-7, pages 211-216](#).

FEE SUMMARY: Pursuant to Section 67-5224(2)(d), Idaho Code, a pending fee rule shall not become final and effective unless affirmatively approved by concurrent resolution of the Legislature. The following is a description of the fee or charge imposed or increased in this rulemaking:

As authorized in Sections 54-4205 and 54-4209, Idaho Code, the fee(s) in this rulemaking are established in Rule 400. The application fee, annual renewal fee, provisional permit fee, and reissuance of lost license fee has been increased from \$150 to \$200.

FISCAL IMPACT: The following is a specific description, if applicable, of any negative fiscal impact on the state General Fund greater than ten thousand dollars (\$10,000) during the fiscal year:

This rulemaking is not anticipated to have any negative fiscal impact on the state General Fund.

ASSISTANCE ON TECHNICAL QUESTIONS: For assistance on technical questions concerning this pending rule, contact Krissy Veseth, Bureau Chief, at (208) 577-2491. Materials pertaining to the pending rulemaking, including any available preliminary rule drafts, can be found on the following DOPL website: <https://dopl.idaho.gov/rulemaking/>.

DATED this 30th day of August, 2024.

Krissy Veseth
Bureau Chief
11341 W. Chinden Blvd., Bldg. #4
Boise, ID 83714
Phone: (208) 577-2491
Email: krissy.veseth@dopl.idaho.gov

IDAPA 24 – DIVISION OF OCCUPATIONAL AND PROFESSIONAL LICENSES

24.21.01 – RULES OF THE IDAHO STATE CONTRACTORS BOARD

DOCKET NO. 24-2101-2401 (ZBR CHAPTER REWRITE)

NOTICE OF RULEMAKING – PROPOSED RULE

AUTHORITY: In compliance with Section 67-5221(1), Idaho Code, notice is hereby given that this agency has initiated proposed rulemaking procedures. This rulemaking action is authorized pursuant to Section 67-2604, Idaho Code, Sections 67-9404, 67-9405, 67- 9406, 67-9409, and 67-9413, Idaho Code, and 54-5201 through 54-5219, Idaho Code.

PUBLIC HEARING SCHEDULE: The public hearing concerning this rulemaking will be held as follows:

24.21.01 – Rules of the Idaho State Contractors Board
Thursday, October 17, 2024 – 9:30 a.m. (MT) Division of Occupational and Professional Licenses EagleRock Room, Chinden Campus Building 4 11341 W. Chinden Blvd. Boise, ID 83714
Virtual Meeting Link
Telephone and web conferencing information will be posted on https://dopl.idaho.gov/calendar/ and https://townhall.idaho.gov/.

The hearing site will be accessible to persons with disabilities, if needed. Requests for accommodation must be made not later than five (5) days prior to the meeting to the agency address below.

DESCRIPTIVE SUMMARY AND STATEMENT OF PURPOSE: The following is a nontechnical explanation of the substance and purpose of the proposed rulemaking:

Under [Executive Order 2020-01, Zero-Based Regulation](#), the Idaho Board of Contractors is striving to prevent the accumulation of costly, ineffective, and outdated regulations and reduce regulatory burden to achieve a more efficient operation of government. In conjunction with stakeholders, the proposed rule changes reflect a comprehensive review of this chapter by collaborating with the public to streamline or simplify the rule language in this chapter and to use plain language for better understanding. This proposed rulemaking updates the rules to comply with governing statute and Executive Order 2020-01.

FEE SUMMARY: The following is a specific description of the fee or charge imposed or increased:

N/A. The proposed amendments to the rules do not impose any new or increased fees.

FISCAL IMPACT: The following is a specific description, if applicable, of any negative fiscal impact on the state General Fund greater than ten thousand dollars (\$10,000) during the fiscal year as a result of this rulemaking:

This rulemaking is not anticipated to have any negative fiscal impact on the state General Fund.

NEGOTIATED RULEMAKING: Pursuant to Section 67-5220, Idaho Code, negotiated rulemaking was conducted under Docket No. 24-2101-2401. Notice of Intent to Promulgate Rules - Negotiated Rulemaking was published in the June 5, 2024, Idaho Administrative Bulletin, [Vol. 24-6, p.72-73](#).

INCORPORATION BY REFERENCE: Pursuant to Section 67-5229(2)(a), Idaho Code, the following is a brief synopsis of why the materials cited are being incorporated by reference into this rule: N/A.

No materials have been incorporated by reference into the proposed rules.

ASSISTANCE ON TECHNICAL QUESTIONS, SUBMISSION OF WRITTEN COMMENTS, OBTAINING DRAFT COPIES: For assistance on technical questions concerning this proposed rule, contact Krissy Veseth, Bureau Chief, at (208) 577-2491. Materials pertaining to the proposed rulemaking, including any available preliminary rule drafts, can be found on the following DOPL website: <https://dopl.idaho.gov/rulemaking/>.

Anyone may submit written comments regarding this proposed rulemaking. All written comments must be directed to the undersigned and must be delivered on or before October 23, 2024.

DATED this 30th day of August, 2024.

Krissy Veseth
Bureau Chief
11341 W. Chinden Blvd., Bldg. #4
Boise, ID 83714
Phone: (208) 577-2491
Email: krissy.veseth@dopl.idaho.gov

THE FOLLOWING IS THE PROPOSED TEXT OF DOCKET NO. 24-2101-2401
(ZBR Chapter Rewrite)

24.21.01 – RULES OF THE IDAHO STATE CONTRACTORS BOARD

000. LEGAL AUTHORITY.

These rules are promulgated pursuant to Sections 54-5206, 67-2604, 67-2614, 67-9409, and 67-9406 Idaho Code. (3-28-23)()

001. SCOPE.

These rules govern the practice and registration of construction and contractors in Idaho. (3-28-23)

002. -- ~~149~~099. (RESERVED)

~~150~~100. APPLICATION REGISTRATION.

The applicant must provide or facilitate the provision of any supplemental third-party documents that may be required. ~~Applications on file with the Board where an applicant has failed to respond to a Board request or where the applications have lacked activity for twelve (12) consecutive months are deemed denied and will be terminated upon thirty (30) days written notice unless good cause is established to the Board.~~ (3-28-23)()

~~151. — 164. (RESERVED)~~

165. ADDITIONAL QUALIFICATIONS FOR REGISTRATION.

01. Additional Qualifications for Registration. Applicants for a registration must meet the following qualifications in addition to those set forth in Section 54-5210, Idaho Code and these rules. (3-28-23)()

~~01a.~~ Felony Conviction. Not have been convicted of any felony in a state or federal court; provided the applicant may make written request to the board for an exemption review to determine the applicant's suitability for registration, which the board determines in accordance with the following: (3-28-23)

~~02b.~~ Exemption Review. The exemption review consists of a review of any documents relating to the felony and any supplemental information provided by the applicant bearing upon his suitability for registration. The board may, at its discretion, grant an interview of the applicant. ~~During the review, the board considers the factors set forth in Section 67-9411, Idaho Code~~ The applicant bears the burden of establishing suitability for registration. (3-28-23)()

~~b.~~ The applicant bears the burden of establishing his current suitability for registration. (3-28-23)

~~03. Fraud in Application Process.~~ The registration application and supporting documents are free from any fraud or material misrepresentations. (3-28-23)

~~16601.~~ -- ~~174399.~~(RESERVED)

~~175400.~~ FEES.
Fees are non-refundable:

FEE TYPE	AMOUNT (Not to Exceed)
Application (includes original registration)	\$50
Reciprocal	\$50
Renewal	\$50
Reinstatement	\$35
Inactive	\$0
Inactive to Active License	The difference between the inactive fee and active license renewal fee

(3-28-23)()

~~176401.~~ -- 999. (RESERVED)

IDAPA 24 – DIVISION OF OCCUPATIONAL AND PROFESSIONAL LICENSES

24.24.01 – RULES OF THE GENETIC COUNSELORS LICENSING BOARD

DOCKET NO. 24-2401-2401 (ZBR CHAPTER REWRITE)

NOTICE OF RULEMAKING – ADOPTION OF PENDING RULE

EFFECTIVE DATE: This rule has been adopted by the agency and is now pending review by the 2025 Idaho State Legislature and must be approved by concurrent resolution of the Legislature to go into effect, in accordance with Section 67-5224(2)(c), Idaho Code. Should the pending rule be approved, it will become final and effective on July 1, 2025, in the year of the First Regular Session of the Sixty-eighth Idaho Legislature, unless the concurrent resolution states a different effective date.

AUTHORITY: In compliance with Section 67-5224, Idaho Code, notice is hereby given that this agency has adopted a pending rule. The action is authorized pursuant to Section 67-2604, Idaho Code, Sections 67-9404, 67-9405, 67-9406, 67-9409, and 67-9413, Idaho Code, and Sections 54-5601 through 54-5616, Idaho Code.

DESCRIPTIVE SUMMARY: The following is a concise explanatory statement of the reasons for adopting the pending rule and a statement of any change between the text of the proposed rule and the text of the pending rule with an explanation of the reasons for the change:

Under [Executive Order 2020-01, Zero-Based Regulation](#), the Idaho Board of Genetic Counselors is striving to prevent the accumulation of costly, ineffective, and outdated regulations and reduce regulatory burden to achieve a more efficient operation of government. There are no changes to the pending rule, and it is being adopted as originally proposed. The complete text of the proposed rule was published in the July 3, 2024, Idaho Administrative Bulletin, [Vol. 24-7, pages 219-223](#).

FEE SUMMARY: Pursuant to Section 67-5224(2)(d), Idaho Code, a pending fee rule shall not become final and effective unless affirmatively approved by concurrent resolution of the Legislature. The following is a description of the fee or charge imposed or increased in this rulemaking:

As authorized in Section 54-5613, Idaho Code, the fees in this rulemaking are established in Rule 400. None of these fees are being changed as a result of this rulemaking or since being previously reviewed by the Idaho Legislature.

FISCAL IMPACT: The following is a specific description, if applicable, of any negative fiscal impact on the state General Fund greater than ten thousand dollars (\$10,000) during the fiscal year:

This rulemaking is not anticipated to have any negative fiscal impact on the state General Fund.

ASSISTANCE ON TECHNICAL QUESTIONS: For assistance on technical questions concerning this pending rule, contact Krissy Veseth, Bureau Chief, at (208) 577-2491. Materials pertaining to the pending rulemaking, including any available preliminary rule drafts, can be found on the following DOPL website: <https://dopl.idaho.gov/rulemaking/>.

DATED this 30th day of August, 2024.

Krissy Veseth
Bureau Chief
11341 W. Chinden Blvd., Bldg. #4
Boise, ID 83714
Phone: (208) 577-2491
Email: krissy.veseth@dopl.idaho.gov

IDAPA 24 – DIVISION OF OCCUPATIONAL AND PROFESSIONAL LICENSES

24.33.01 – RULES OF THE BOARD OF MEDICINE FOR THE PRACTICE OF MEDICINE AND OSTEOPATHIC MEDICINE IN IDAHO

DOCKET NO. 24-3301-2401 (ZBR CHAPTER REWRITE, FEE RULE)

NOTICE OF RULEMAKING – ADOPTION OF PENDING RULE

EFFECTIVE DATE: This rule has been adopted by the agency and is now pending review by the 2025 Idaho State Legislature and must be approved by concurrent resolution of the Legislature to go into effect, in accordance with Section 67-5224(2)(c), Idaho Code. Should the pending rule be approved, it will become final and effective on July 1, 2025, in the year of the First Regular Session of the Sixty-eighth Idaho Legislature, unless the concurrent resolution states a different effective date.

AUTHORITY: In compliance with Section 67-5224, Idaho Code, notice is hereby given that this agency has adopted a pending rule. This rulemaking action is authorized pursuant to Section 67-2604, Idaho Code, and Sections 67-1002, 54-1806, 54-1806A, 54-1807, 54-1812, 54-1813, 54-1814, 54-1841, 54-1867, 67-2614, 67-9406 and 67-9409, Idaho Code.

DESCRIPTIVE SUMMARY: The following is a concise explanatory statement of the reasons for adopting the pending rule and a statement of any change between the text of the proposed rule and the text of the pending rule with an explanation of the reasons for the change:

Under [Executive Order 2020-01, Zero-Based Regulation](#), the Idaho State Board of Medicine is striving to prevent the accumulation of costly, ineffective, and outdated regulations and reduce regulatory burden to achieve a more efficient operation of government. In conjunction with stakeholders, the pending rule reflects a comprehensive review of this chapter by collaborating with the public to streamline or simplify the rule language in this chapter and to use plain language for better understanding. It also amends the rules in response to recent statutes passed by the Idaho Legislature: HB542a (2024) and HB153 (2023). There are no changes to the pending rule, and it is being adopted as originally proposed. The complete text of the proposed rule was published in the July 3, 2024, Idaho Administrative Bulletin, [Vol. 24-7, pages 224-235](#).

FEE SUMMARY: Pursuant to Section 67-5224(2)(d), Idaho Code, a pending fee rule shall not become final and effective unless affirmatively approved by concurrent resolution of the Legislature. The following is a description of the fee or charge imposed or increased in this rulemaking:

As authorized in Sections 54-1807, 54-1808, 54-1813, 54-1867, Idaho Code, the fees in this rulemaking are established in Rule 400. The pending rules create new license types of a three-year provisional license for international physicians, pursuant to HB542a (2024), and a single-year license for bridge year physicians, pursuant to HB153 (2023), and impose new fees of up to \$300 for each license type, consistent with the statutes.

FISCAL IMPACT: The following is a specific description, if applicable, of any negative fiscal impact on the state general fund greater than ten thousand dollars (\$10,000) during the fiscal year:

This rulemaking is not anticipated to have any negative fiscal impact on the State General Fund.

ASSISTANCE ON TECHNICAL QUESTIONS: For assistance on technical questions concerning this pending rule, contact Krissy Veseth, Bureau Chief, at (208) 577-2491. Materials pertaining to the pending rulemaking, including any available preliminary rule drafts, can be found on the following DOPL website: <https://dopl.idaho.gov/rulemaking/>.

DATED this 30th day of August, 2024.

Krissy Veseth
Bureau Chief
11341 W. Chinden Blvd., Bldg. #4
Boise, ID 83714
Phone: (208) 577-2491
Email: krissy.veseth@dopl.idaho.gov

IDAPA 24 – DIVISION OF OCCUPATIONAL AND PROFESSIONAL LICENSES

24.33.02 – RULES FOR THE LICENSURE OF PHYSICIAN ASSISTANTS

DOCKET NO. 24-3302-2401 (ZBR CHAPTER REWRITE)

NOTICE OF RULEMAKING – ADOPTION OF PENDING RULE

EFFECTIVE DATE: This rule has been adopted by the agency and is now pending review by the 2025 Idaho State Legislature and must be approved by concurrent resolution of the Legislature to go into effect, in accordance with Section 67-5224(2)(c), Idaho Code. Should the pending rule be approved, it will become final and effective on July 1, 2025, in the year of the First Regular Session of the Sixty-eighth Idaho Legislature, unless the concurrent resolution states a different effective date.

AUTHORITY: In compliance with Section 67-5224, Idaho Code, notice is hereby given that this agency has adopted a pending rule. This rulemaking action is authorized pursuant to Section 67-2604, Idaho Code, and Sections 54-1806, 54-1807A, 67-2614, 67-9406 and 67-9409, Idaho Code.

DESCRIPTIVE SUMMARY: The following is a concise explanatory statement of the reasons for adopting the pending rule and a statement of any change between the text of the proposed rule and the text of the pending rule with an explanation of the reasons for the change:

Under [Executive Order 2020-01, Zero-Based Regulation](#), the Idaho State Board of Medicine is striving to prevent the accumulation of costly, ineffective, and outdated regulations and reduce regulatory burden to achieve a more efficient operation of government. In conjunction with stakeholders, the pending rule reflects a comprehensive review of this chapter by collaborating with the public to streamline or simplify the rule language in this chapter and to use plain language for better understanding. There are no changes to the pending rule, and it is being adopted as originally proposed. The complete text of the proposed rule was published in the July 3, 2024, Idaho Administrative Bulletin, [Vol. 24-7, pages 236-239](#).

FEE SUMMARY: Pursuant to Section 67-5224(2)(d), Idaho Code, a pending fee rule shall not become final and effective unless affirmatively approved by concurrent resolution of the Legislature. The following is a description of the fee or charge imposed or increased in this rulemaking:

As authorized in Sections 54-1807, 54-1808, 54-1813, 54-1867, Idaho Code, the fees in this rulemaking are established in Rule 400. The pending rules do not impose any new or increased fees.

FISCAL IMPACT: The following is a specific description, if applicable, of any negative fiscal impact on the state General Fund greater than ten thousand dollars (\$10,000) during the fiscal year:

This rulemaking is not anticipated to have any negative fiscal impact on the state General Fund.

ASSISTANCE ON TECHNICAL QUESTIONS: For assistance on technical questions concerning this pending rule, contact Krissy Veseth, Bureau Chief, at (208) 577-2491. Materials pertaining to the pending rulemaking, including any available preliminary rule drafts, can be found on the following DOPL website: <https://dopl.idaho.gov/rulemaking/>.

DATED this 30th day of August, 2024.

Krissy Veseth
Bureau Chief
11341 W. Chinden Blvd., Bldg. #4
Boise, ID 83714
Phone: (208) 577-2491
Email: krissy.veseth@dopl.idaho.gov

IDAPA 24 – DIVISION OF OCCUPATIONAL AND PROFESSIONAL LICENSES

24.33.03 – GENERAL PROVISIONS OF THE BOARD OF MEDICINE

DOCKET NO. 24-3303-2401 (ZBR CHAPTER REPEAL)

NOTICE OF RULEMAKING – ADOPTION OF PENDING RULE

EFFECTIVE DATE: This rule has been adopted by the agency and is now pending review by the 2025 Idaho State Legislature and must be approved by concurrent resolution of the Legislature to go into effect, in accordance with Section 67-5224(2)(c), Idaho Code. Should the pending rule be approved, it will become final and effective on July 1, 2025, in the year of the First Regular Session of the Sixty-eighth Idaho Legislature, unless the concurrent resolution states a different effective date.

AUTHORITY: In compliance with Section 67-5224, Idaho Code, notice is hereby given that this agency has adopted a pending rule. This rulemaking action is authorized pursuant to Section 67-2604, Idaho Code, and Section 54-1806, 54-1806A, 54-1807, 54-1812, 54-1813, 54-1814, 54-1841, 54-1867, 67-2614, 67-9406 and 67-9409, Idaho Code.

DESCRIPTIVE SUMMARY: The following is a concise explanatory statement of the reasons for adopting the pending rule and a statement of any change between the text of the proposed rule and the text of the pending rule with an explanation of the reasons for the change:

This chapter of administrative rules is being repealed. All necessary provisions have been moved and combined into DAPA 24.33.01, Rules of the Board of Medicine for the Practice of Medicine and Osteopathic Medicine in Idaho, under companion docket 24-3301-2401 in this bulletin. There are no changes to the pending rule, and it is being adopted as originally proposed. The complete text of the proposed rule was published in the July 3, 2024, Idaho Administrative Bulletin, [Vol. 24-7, pages 240-241](#).

FEE SUMMARY: Pursuant to Section 67-5224(2)(d), Idaho Code, a pending fee rule shall not become final and effective unless affirmatively approved by concurrent resolution of the Legislature. The following is a description of the fee or charge imposed or increased in this rulemaking: N/A.

FISCAL IMPACT: The following is a specific description, if applicable, of any negative fiscal impact on the state General Fund greater than ten thousand dollars (\$10,000) during the fiscal year:

This rulemaking is not anticipated to have any negative fiscal impact on the state General Fund.

ASSISTANCE ON TECHNICAL QUESTIONS: For assistance on technical questions concerning this pending rule, contact Krissy Veseth, Bureau Chief, at (208) 577-2491. Materials pertaining to the pending rulemaking, including any available preliminary rule drafts, can be found on the following DOPL website: <https://dopl.idaho.gov/rulemaking/>.

DATED this 30th day of August, 2024.

Krissy Veseth
Bureau Chief
11341 W. Chinden Blvd., Bldg. #4
Boise, ID 83714
Phone: (208) 577-2491
Email: krissy.veseth@dopl.idaho.gov

IDAPA 24 – DIVISION OF OCCUPATIONAL AND PROFESSIONAL LICENSES

24.33.04 – RULES FOR THE LICENSURE OF NATUROPATHIC MEDICAL DOCTORS

DOCKET NO. 24-3304-2401 (ZBR CHAPTER REWRITE)

NOTICE OF RULEMAKING – ADOPTION OF PENDING RULE

EFFECTIVE DATE: This rule has been adopted by the agency and is now pending review by the 2025 Idaho State Legislature and must be approved by concurrent resolution of the Legislature to go into effect, in accordance with Section 67-5224(2)(c), Idaho Code. Should the pending rule be approved, it will become final and effective on July 1, 2025, in the year of the First Regular Session of the Sixty-eighth Idaho Legislature, unless the concurrent resolution states a different effective date.

AUTHORITY: In compliance with Section 67-5224, Idaho Code, notice is hereby given that this agency has adopted a pending rule. This rulemaking action is authorized pursuant to Section 67-2604, Idaho Code, and Sections 54-5102, 54-5105, 54-5108, 67-2614, 67-9406 and 67-9409, Idaho Code.

DESCRIPTIVE SUMMARY: The following is a concise explanatory statement of the reasons for adopting the pending rule and a statement of any change between the text of the proposed rule and the text of the pending rule with an explanation of the reasons for the change:

Under [Executive Order 2020-01, Zero-Based Regulation](#), the Idaho State Board of Medicine is striving to prevent the accumulation of costly, ineffective, and outdated regulations and reduce regulatory burden to achieve a more efficient operation of government. In conjunction with stakeholders, the pending rule reflects a comprehensive review of this chapter by collaborating with the public to streamline or simplify the rule language in this chapter and to use plain language for better understanding. There are no changes to the pending rule, and it is being adopted as originally proposed. The complete text of the proposed rule was published in the July 3, 2024, Idaho Administrative Bulletin, [Vol. 24-7, pages 242-246](#).

FEE SUMMARY: Pursuant to Section 67-5224(2)(d), Idaho Code, a pending fee rule shall not become final and effective unless affirmatively approved by concurrent resolution of the Legislature. The following is a description of the fee or charge imposed or increased in this rulemaking:

As authorized in Sections 54-5108, Idaho Code, the fees in this rulemaking are established in Rule 400. The pending rules do not impose any new or increased fees.

FISCAL IMPACT: The following is a specific description, if applicable, of any negative fiscal impact on the state general fund greater than ten thousand dollars (\$10,000) during the fiscal year:

This rulemaking is not anticipated to have any negative fiscal impact on the State General Fund.

ASSISTANCE ON TECHNICAL QUESTIONS: For assistance on technical questions concerning this pending rule, contact Krissy Veseth, Bureau Chief, at (208) 577-2491. Materials pertaining to the pending rulemaking, including any available preliminary rule drafts, can be found on the following DOPL website: <https://dopl.idaho.gov/rulemaking/>.

DATED this 30th day of August, 2024.

Krissy Veseth
Bureau Chief
11341 W. Chinden Blvd., Bldg. #4
Boise, ID 83714
Phone: (208) 577-2491
Email: krissy.veseth@dopl.idaho.gov

IDAPA 24 – DIVISION OF OCCUPATIONAL AND PROFESSIONAL LICENSES

24.33.05 – RULES FOR THE LICENSURE OF ATHLETIC TRAINERS TO PRACTICE IN IDAHO

DOCKET NO. 24-3305-2401 (ZBR CHAPTER REWRITE)

NOTICE OF RULEMAKING – ADOPTION OF PENDING RULE

EFFECTIVE DATE: This rule has been adopted by the agency and is now pending review by the 2025 Idaho State Legislature and must be approved by concurrent resolution of the Legislature to go into effect, in accordance with Section 67-5224(2)(c), Idaho Code. Should the pending rule be approved, it will become final and effective on July 1, 2025, in the year of the First Regular Session of the Sixty-eighth Idaho Legislature, unless the concurrent resolution states a different effective date.

AUTHORITY: In compliance with Section 67-5224, Idaho Code, notice is hereby given that this agency has adopted a pending rule. This rulemaking action is authorized pursuant to Section 67-2604, Idaho Code, and Sections 54-3902, 54-3906, 54-3907, 54-3910, 54-3911, 54-3913, 67-2614, 67-9406 and 67-9409, Idaho Code.

DESCRIPTIVE SUMMARY: The following is a concise explanatory statement of the reasons for adopting the pending rule and a statement of any change between the text of the proposed rule and the text of the pending rule with an explanation of the reasons for the change:

Under [Executive Order 2020-01, Zero-Based Regulation](#), the Idaho State Board of Medicine is striving to prevent the accumulation of costly, ineffective, and outdated regulations and reduce regulatory burden to achieve a more efficient operation of government. In conjunction with stakeholders, the pending rule reflects a comprehensive review of this chapter by collaborating with the public to streamline or simplify the rule language in this chapter and to use plain language for better understanding. There are no changes to the pending rule, and it is being adopted as originally proposed. The complete text of the proposed rule was published in the July 3, 2024, Idaho Administrative Bulletin, [Vol. 24-7, pages 247-251](#).

FEE SUMMARY: Pursuant to Section 67-5224(2)(d), Idaho Code, a pending fee rule shall not become final and effective unless affirmatively approved by concurrent resolution of the Legislature. The following is a description of the fee or charge imposed or increased in this rulemaking:

As authorized in Sections 54-3907, Idaho Code, the fees in this rulemaking are established in Rule 400. The pending rules do not impose any new or increased fees.

FISCAL IMPACT: The following is a specific description, if applicable, of any negative fiscal impact on the state General Fund greater than ten thousand dollars (\$10,000) during the fiscal year:

This rulemaking is not anticipated to have any negative fiscal impact on the state General Fund.

ASSISTANCE ON TECHNICAL QUESTIONS: For assistance on technical questions concerning this pending rule, contact Krissy Veseth, Bureau Chief, at (208) 577-2491. Materials pertaining to the pending rulemaking, including any available preliminary rule drafts, can be found on the following DOPL website: <https://dopl.idaho.gov/rulemaking/>.

DATED this 30th day of August, 2024.

Krissy Veseth
Bureau Chief
11341 W. Chinden Blvd., Bldg. #4
Boise, ID 83714
Phone: (208) 577-2491
Email: krissy.veseth@dopl.idaho.gov

IDAPA 24 – DIVISION OF OCCUPATIONAL AND PROFESSIONAL LICENSES

24.33.06 – RULES FOR LICENSURE OF RESPIRATORY THERAPISTS AND PERMITTING OF POLYSOMNOGRAPHERS IN IDAHO

DOCKET NO. 24-3306-2401 (ZBR CHAPTER REWRITE)

NOTICE OF RULEMAKING – ADOPTION OF PENDING RULE

EFFECTIVE DATE: This rule has been adopted by the agency and is now pending review by the 2025 Idaho State Legislature and must be approved by concurrent resolution of the Legislature to go into effect, in accordance with Section 67-5224(2)(c), Idaho Code. Should the pending rule be approved, it will become final and effective on July 1, 2025, in the year of the First Regular Session of the Sixty-eighth Idaho Legislature, unless the concurrent resolution states a different effective date.

AUTHORITY: In compliance with Section 67-5224, Idaho Code, notice is hereby given that this agency has adopted a pending rule. This rulemaking action is authorized pursuant to Section 67-2604, Idaho Code, and Sections 54-4305, 54-4306, 54-4309, 54-4310, 54-4311, 67-2614, 67-9406 and 67-9409, Idaho Code.

DESCRIPTIVE SUMMARY: The following is a concise explanatory statement of the reasons for adopting the pending rule and a statement of any change between the text of the proposed rule and the text of the pending rule with an explanation of the reasons for the change:

Under [Executive Order 2020-01, Zero-Based Regulation](#), the Idaho State Board of Medicine is striving to prevent the accumulation of costly, ineffective, and outdated regulations and reduce regulatory burden to achieve a more efficient operation of government. In conjunction with stakeholders, the pending rule reflects a comprehensive review of this chapter by collaborating with the public to streamline or simplify the rule language in this chapter and to use plain language for better understanding. There are no changes to the pending rule, and it is being adopted as originally proposed. The complete text of the proposed rule was published in the July 3, 2024, Idaho Administrative Bulletin, [Vol. 24-7, pages 252-256](#).

FEE SUMMARY: Pursuant to Section 67-5224(2)(d), Idaho Code, a pending fee rule shall not become final and effective unless affirmatively approved by concurrent resolution of the Legislature. The following is a description of the fee or charge imposed or increased in this rulemaking:

As authorized in Sections 54-4309, Idaho Code, the fees in this rulemaking are established in Rule 400. The pending rules do not impose any new or increased fees.

FISCAL IMPACT: The following is a specific description, if applicable, of any negative fiscal impact on the state General Fund greater than ten thousand dollars (\$10,000) during the fiscal year:

This rulemaking is not anticipated to have any negative fiscal impact on the state General Fund.

ASSISTANCE ON TECHNICAL QUESTIONS: For assistance on technical questions concerning this pending rule, contact Krissy Veseth, Bureau Chief, at (208) 577-2491. Materials pertaining to the pending rulemaking, including any available preliminary rule drafts, can be found on the following DOPL website: <https://dopl.idaho.gov/rulemaking/>.

DATED this 30th day of August, 2024.

Krissy Veseth
Bureau Chief
11341 W. Chinden Blvd., Bldg. #4
Boise, ID 83714
Phone: (208) 577-2491
Email: krissy.veseth@dopl.idaho.gov

IDAPA 24 – DIVISION OF OCCUPATIONAL AND PROFESSIONAL LICENSES

24.33.07 – RULES FOR THE LICENSURE OF DIETITIANS

DOCKET NO. 24-3307-2401 (ZBR CHAPTER REWRITE)

NOTICE OF RULEMAKING – ADOPTION OF PENDING RULE

EFFECTIVE DATE: This rule has been adopted by the agency and is now pending review by the 2025 Idaho State Legislature and must be approved by concurrent resolution of the Legislature to go into effect, in accordance with Section 67-5224(2)(c), Idaho Code. Should the pending rule be approved, it will become final and effective on July 1, 2025, in the year of the First Regular Session of the Sixty-eighth Idaho Legislature, unless the concurrent resolution states a different effective date.

AUTHORITY: In compliance with Section 67-5224, Idaho Code, notice is hereby given that this agency has adopted a pending rule. This rulemaking action is authorized pursuant to Section 67-2604, Idaho Code, and Sections 54-3505, 54-3509, 67-2614, 67-9406 and 67-9409, Idaho Code.

DESCRIPTIVE SUMMARY: The following is a concise explanatory statement of the reasons for adopting the pending rule and a statement of any change between the text of the proposed rule and the text of the pending rule with an explanation of the reasons for the change:

Under [Executive Order 2020-01, Zero-Based Regulation](#), the Idaho State Board of Medicine is striving to prevent the accumulation of costly, ineffective, and outdated regulations and reduce regulatory burden to achieve a more efficient operation of government. In conjunction with stakeholders, the pending rule reflects a comprehensive review of this chapter by collaborating with the public to streamline or simplify the rule language in this chapter and to use plain language for better understanding. There are no changes to the pending rule, and it is being adopted as originally proposed. The complete text of the proposed rule was published in the July 3, 2024, Idaho Administrative Bulletin, [Vol. 24-7, pages 257-259](#).

FEE SUMMARY: Pursuant to Section 67-5224(2)(d), Idaho Code, a pending fee rule shall not become final and effective unless affirmatively approved by concurrent resolution of the Legislature. The following is a description of the fee or charge imposed or increased in this rulemaking:

As authorized in Sections 54-3509, Idaho Code, the fees in this rulemaking are established in Rule 400. The pending rules do not impose any new or increased fees.

FISCAL IMPACT: The following is a specific description, if applicable, of any negative fiscal impact on the state General Fund greater than ten thousand dollars (\$10,000) during the fiscal year:

This rulemaking is not anticipated to have any negative fiscal impact on the state General Fund.

ASSISTANCE ON TECHNICAL QUESTIONS: For assistance on technical questions concerning this pending rule, contact Krissy Veseth, Bureau Chief, at (208) 577-2491. Materials pertaining to the pending rulemaking, including any available preliminary rule drafts, can be found on the following DOPL website: <https://dopl.idaho.gov/rulemaking/>.

DATED this 30th day of August, 2024.

Krissy Veseth
Bureau Chief
11341 W. Chinden Blvd., Bldg. #4
Boise, ID 83714
Phone: (208) 577-2491
Email: krissy.veseth@dopl.idaho.gov

IDAPA 24 – DIVISION OF OCCUPATIONAL AND PROFESSIONAL LICENSES

24.39.10 – RULES OF THE IDAHO ELECTRICAL BOARD

DOCKET NO. 24-3910-2402

NOTICE OF RULEMAKING – PROPOSED RULE

AUTHORITY: In compliance with Section 67-5221(1), Idaho Code, notice is hereby given that this agency has initiated proposed rulemaking procedures. This rulemaking action is authorized pursuant to Section 67-2604, Idaho Code, Sections 67-9404, 67-9405, 67- 9406, 67-9409, and 67-9413, Idaho Code, as well as Title 54, Chapter 10, Idaho Code and 54-1006, Idaho Code.

PUBLIC HEARING SCHEDULE: The public hearing concerning this rulemaking will be held as follows:

24.39.10 – Rules of the Idaho Electrical Board
Thursday, October 17, 2024 – 3 p.m. (MT) Division of Occupational and Professional Licenses Coolwater Room, Chinden Campus Building 4 11341 W. Chinden Blvd. Boise, ID 83714
Virtual Meeting Link
Telephone and web conferencing information will be posted on https://dopl.idaho.gov/calendar/ and https://townhall.idaho.gov/.

The hearing site will be accessible to persons with disabilities, if needed. Requests for accommodation must be made not later than five (5) days prior to the meeting to the agency address below.

DESCRIPTIVE SUMMARY AND STATEMENT OF PURPOSE: The following is a nontechnical explanation of the substance and purpose of the proposed rulemaking:

The Idaho Electrical Board’s administrative rules were not approved by concurrent resolution during the 2024 legislative session, as required by Idaho Code Section 67-5291. As a result, the board adopted temporary rules, which will expire *sine die* unless approved by concurrent resolution. In order to ensure continuity of rules and to promote public health and safety, the board engaged in negotiated rulemaking and held six (6) public hearings throughout the state of Idaho for public comment before the Idaho Electrical Board voted to go proposed with the redlines attached in this bulletin.

FEE SUMMARY: The following is a specific description of the fee or charge imposed or increased:

N/A. The proposed amendments to the rules do not impose any new or increased fees.

FISCAL IMPACT: The following is a specific description, if applicable, of any negative fiscal impact on the state General Fund greater than ten thousand dollars (\$10,000) during the fiscal year as a result of this rulemaking:

This rulemaking is not anticipated to have any negative fiscal impact on the state General Fund.

NEGOTIATED RULEMAKING: Pursuant to Section 67-5220, Idaho Code, negotiated rulemaking was conducted under Docket No. 24-2101-2401. Notice of Intent to Promulgate Rules - Negotiated Rulemaking was published in the July 3, 2024, Idaho Administrative Bulletin, [Vol. 24-7, p.260-262](#).

INCORPORATION BY REFERENCE: Pursuant to Section 67-5229(2)(a), Idaho Code, the following is a brief synopsis of why the materials cited are being incorporated by reference into this rule:

N/A. No materials have been incorporated by reference into the proposed rules.

ASSISTANCE ON TECHNICAL QUESTIONS, SUBMISSION OF WRITTEN COMMENTS, OBTAINING DRAFT COPIES: For assistance on technical questions concerning this proposed rule, contact Krissy Veseth, Bureau Chief, at (208) 577-2491. Materials pertaining to the proposed rulemaking, including any available preliminary rule drafts, can be found on the following DOPL website: <https://dopl.idaho.gov/rulemaking/>.

Anyone may submit written comments regarding this proposed rulemaking. All written comments must be directed to the undersigned and must be delivered on or before October 23, 2024.

DATED this 30th day of August 30, 2024.

Krissy Veseth
Bureau Chief
11341 W. Chinden Blvd., Bldg. #4
Boise, ID 83714
Phone: (208) 577-2491
Email: krissy.veseth@dopl.idaho.gov

THE FOLLOWING IS THE PROPOSED TEXT OF DOCKET NO. 24-3910-2402
(Only Those Sections With Amendments Are Shown.)

24.39.10 – RULES OF THE IDAHO ELECTRICAL BOARD

100. LICENSURE AND REGISTRATION.

01. Residential Electrician. An applicant must pass an examination designated by the Board and submit evidence of a minimum of four thousand (4,000) hours of work experience and an apprentice making installations as defined in Section 54-1003A(3), Idaho Code, and satisfactory completion of a two-year sequence of instruction approved by the Idaho Division of Career Technical Education and the Idaho Electrical Board. ()

042. Journeyman Electrician. An applicant must pass an examination designated by the Board and either (a) submit evidence of a minimum of eight thousand (8,000) hours of work experience as an apprentice making electrical installations in accordance with the requirements of the jurisdiction in which the applicant obtained the experience and satisfactory completion of a four-year sequence of instruction approved by the Idaho Division of Career-Technical Education, or (b) submit proof of sixteen thousand (16,000) hours of electrical experience in accordance with the requirements of the jurisdiction in which the applicant obtained the experience. ~~(3-28-23)~~()

a. Examination. An applicant may sit for the exam after showing proof of completion of either the approved 4-year sequence of instruction or 16,000 hours of electrical experience. (3-28-23)

b. Provisional Journeyman ~~License~~ Electrician. A provisional journeyman electrician license can be issued to an applicant who has completed the 16,000 hours of electrical experience but has not yet passed the examination. ~~(3-28-23)~~()

c. Work experience in appliance repair, motor winding, or communications will not count towards the requirements to take the journeyman examination or obtain a provisional journeyman or journeyman license.

(3-28-23)

d. No more than two thousand (2,000) hours of work experience gained while engaged in the practice of a limited electrical installer or trainee may be counted toward the satisfaction of the experience requirements for journeyman licensure. (3-28-23)

023. Master Electrician. A master electrician does not need to also hold a journeyman license. ~~(3-28-23)~~()

034. Limited Electrical Installer. An applicant must submit evidence of a minimum of four thousand (4,000) hours of work experience in the same limited category in accordance with the requirements of the jurisdiction in which the applicant obtained the experience. (3-28-23)

045. Electrical Contractor and Limited Electrical Contractor. ~~Applicant or its entity designee~~ An applicant must pass an examination designated by the Board and submit an application ~~signed by the applicant or an official representative of the entity making the application and countersigned by the supervising electrician.~~ Each contractor shall designate one supervising electrician who shall be responsible for the activities of the license. Any such supervising electrician shall not represent any other applicant for a contractor's license. A supervising electrician holding more than one electrician license shall not use multiple licenses to represent more than one contractor. (3-28-23)()

~~a. An entity applicant (such as, corporation, partnership, company, firm, or association) must designate in writing an individual to represent it for examination purposes. Any such designee shall be a supervisory employee and may not represent any other applicant for a contractor's license. (3-28-23)~~

~~ba. In the event the working relationship between a contractor and its designee supervising electrician terminates, the contractor will notify the Division in writing within ten (10) business days of the date of termination. The contractor may not purchase permits or make electrical installations unless another duly qualified designee passes the contractor's examination on behalf of the contractor supervising electrician is designated. (3-28-23)~~()

06. Continuing Education. To renew a license, residential electricians, journeyman electricians, and master electricians must provide proof of completion of continuing education obtained during the prior three-year license cycle which consists of sixteen (16) hours of Idaho Electrical Code training and eight (8) hours of any combination of National Electrical Code code-update training, code-related training, industry-related training, or independent study as approved by the division of occupational and professional licenses. ()

101. – 199. (RESERVED)

200. PRACTICE STANDARDS.

01. Electrical Contracting Work. Contracting work includes electrical maintenance or repair work, in addition to new electrical installations, unless such work is expressly exempted by Section 54-1016, Idaho Code. (3-28-23)

02. Contractor Scope. A contractor's allowable scope of work is the same as the scope of its licensed employee. (3-28-23)

03. Supervision. (3-28-23)

a. The master electrician, journeyman electrician, residential electrician or limited electrical installer shall be designated the supervising electrician; must be available during working hours to carry out the duties of supervising, as set forth herein; and will be responsible for supervision of electrical installations made by said contractor as provided by Section 54-1010, Idaho Code. Any supervisory activities shall fall within the supervising electrician's licensed scope of practice. (3-28-23)()

i. A master electrician, journeyman electrician, residential electrician, or limited electrical installer is not qualified for one (1) year as the supervising electrician if his contractor license was revoked. (3-28-23)()

ii. An individual contractor may act as his own supervising master electrician, journeyman electrician, residential electrician, or limited electrical installer upon the condition that he holds an active master electrician, journeyman electrician, residential electrician, or limited electrical installer license. (3-28-23)()

b. The employing contractor or limited electrical contractor must ensure each apprentice, trainee, and provisional journeyman electrician performs electrical work only under the constant on-the-job supervision and training of a master electrician, journeyman electrician, residential electrician or limited electrical installer. (3-28-23)()

c. A journeyman who is an employee of a company, corporation, firm, or association with a facility account may sign as supervising electrician for that facility account in addition to signing as supervising journeyman for his own contractor's license so long as the journeyman is listed as the owner. (3-28-23)

04. Connecting and Energizing Prior to Inspections. At the request of a licensed electrical contractor and upon receipt of a copy of an electrical permit, a power supply company may connect and energize an electrical service, to the line side of the service disconnect, prior to a passed inspection in the following situations: to preserve life or property or to provide temporary service for construction. Any contractor energizing an electrical installation prior to an inspection assumes full responsibility for the installation. (3-28-23)

05. Limited Electrical Installations. A limited electrical installer must be employed by an electrical contractor or limited electrical contractor in the same restricted category and may only countersign a limited electrical contractor's license application as supervising limited electrical installer for work within the same restricted category. Limited electrical installations must comply with the National Electrical Code, as amended herein. The following categories of electrical installations constitute limited electrical installations, the practice of which shall require an electrical contractor or limited electrical contractor license and supervision by a journeyman, master electrician, or limited electrical installer: (3-28-23)

a. Elevator, Dumbwaiter, Escalator, or Moving-Walk Electrical. An elevator electrical limited licensee is only authorized to install, maintain, repair, and replace equipment, controls, and wiring beyond the disconnect switch in the machine room of the elevator and pertaining directly to the operation and control thereof when located in the elevator shaft and machine room. (3-28-23)

b. Sign Electrical. A sign electrical limited licensee is only authorized to install, maintain, repair, and replace equipment, controls, and wiring on the secondary side of sign disconnecting means; provided the disconnecting means is located on the sign or within sight therefrom. (3-28-23)

c. Manufacturing or Assembling Equipment. A licensed limited electrical manufacturing or assembling equipment installer is only authorized to install, maintain, repair, and replace equipment, controls, and accessory wiring, integral to the specific equipment, on the load side of the equipment disconnecting means. Electrical service and feeder are to be installed by others. The licensee may also install circuitry in modules or fabricated enclosures for the purpose of connecting the necessary components which individually bear a label from a nationally recognized testing laboratory when such equipment is designed and manufactured for a specific job installation. (3-28-23)

i. This subsection does not apply to a limited electrical manufacturing or assembling equipment installer installing electrical wiring, equipment, and apparatus in modular buildings as that phrase is defined in Section 39-4105, Idaho Code. Only journeyman electricians and electrical apprentices, employed by an electrical contractor, may perform such installations. (3-28-23)

d. Limited Energy Electrical. Limited energy systems are defined as fire and security alarm systems, class 2 and class 3 signaling circuits, key card operators, nurse call systems, motor and electrical apparatus controls and other limited energy applications covered by the NEC. Unless exempted by Section 54-1016, Idaho Code, any person who installs, maintains, replaces or repairs electrical wiring and equipment for limited energy systems in facilities other than one (1) or two (2) family dwellings shall be required to have a valid limited energy limited electrical license. (3-28-23)

i. Limited energy systems do not include, and no license of any type is required for, the installation of landscape sprinkler controls or communication circuits, wires and apparatus that include telephone systems, telegraph facilities, outside wiring for fire and security alarm systems which are used for communication purposes, and central station systems of a similar nature, PBX systems, audio-visual and sound systems, public address and intercom systems, data communication systems, radio and television systems, antenna systems and other similar systems. (3-28-23)

e. Irrigation Sprinkler Electrical. An irrigation system electrical limited licensee is only authorized to install, maintain, repair and replace equipment, controls and wiring beyond the disconnect switch supplying power to the electric irrigation machine. The irrigation machine is considered to include the hardware, motors and controls of the irrigation machine and underground conductors connecting the control centers on the irrigation machine to the load side of the disconnecting device. Disconnect device to be installed by others. (3-28-23)

f. Well Driller and Installer. ()

g. Water Pump Installer. A license holder in this category is only authorized to perform the following types of installations: (3-28-23)

i. Single or three (3) phase water pumps: install, maintain, repair and replace all electrical equipment, wires, and accessories from the pump motor up to the load side, including fuses, of the disconnecting device. Disconnecting device to be installed by others. (3-28-23)

ii. Domestic water pumps, one hundred twenty/two hundred forty (120/240) volt, single phase, sixty (60) amps or less: install, maintain, repair and replace all electrical equipment, wires, and accessories from the pump motor up to and including the disconnecting device. (3-28-23)

iii. Temporarily connect into a power source to test the installations, provided that all test wiring is removed before the installer leaves the site. (3-28-23)

iv. Individual residential wastewater pumping units. Install, maintain, repair and replace all electrical equipment, wires, and accessories from the pump motor up to and including the disconnecting device for systems that serve one-family, two-family, or three-family residential installations. (3-28-23)

gh. Refrigeration, Heating, and Air-Conditioning Electrical Installer. A license holder in this category is only authorized to perform the following types of installations, which installations shall be limited to factory-assembled, packaged units: (3-28-23)

i. Heating Units (single phase): install, repair, and maintain all electrical equipment, wires, and accessories from the unit up to the load side, including fuses, of the disconnecting device. Disconnecting device to be installed by others. (3-28-23)

ii. Refrigeration, Air-Conditioning Equipment and Heat Pumps (single phase): install, repair, and maintain all electrical equipment, wires, and accessories from the unit up to the load side, including fuses, of the disconnecting device. Disconnecting device to be installed by others. (3-28-23)

iii. Refrigeration, Air-Conditioning and Heating Systems (three (3) phase): install, maintain, and repair all electrical equipment and accessories up to the load side, including fuses, of the disconnecting device. Disconnecting device to be installed by others. (3-28-23)

hi. Outside Wireman. Applicants for this license category shall provide documentation of having completed an electrical lineman apprenticeship program or similar program approved by the U.S. Department of Labor, Office of Apprenticeship. Any person currently licensed in this category is only authorized to perform the following types of installation (3-28-23)

i. Overhead distribution and transmission lines in excess of six hundred (600) volts (3-28-23)

ii. Underground distribution and transmission lines in excess of six hundred (600) volts. (3-28-23)

- iii. Substation and switchyard construction in excess of six hundred (600) volts. (3-28-23)
- ij.** Solar Photovoltaic. Applicants for this license category shall provide proof of photovoltaic installer certification by the North American Board of Certified Energy Practitioners (NABCEP) or equivalent. Any person licensed in this category is only authorized to perform the following types of installations: (3-28-23)
- i. Solar Photovoltaic DC Systems: Install, maintain, repair, and replace all electrical equipment, wires, and accessories up to and including the inverter. (3-28-23)
- ii. Solar Photovoltaic micro-inverter/AC Systems: Install, maintain, repair, and replace all electrical equipment, wires, and accessories up to and including the AC combiner box. (3-28-23)
- 06. Certification and Approval of Electrical Products and Materials.** All materials, devices, fittings, equipment, apparatus, luminaires, and appliances installed or to be used in installations that are supplied with electric energy must be approved as provided in one (1) of the following methods: (3-28-23)
- a.** Testing Laboratory. Be tested, examined, and certified (Listed) by a Nationally Recognized Testing Laboratory (NRTL). (3-28-23)
- b.** Field Evaluation. Non-listed electrical equipment may be approved for use through a field evaluation process performed in accordance with recognized practices and procedures such as those contained in the 2012 edition of NFPA 791 - Recommended Practice and Procedures for Unlabeled Electrical Equipment Evaluation published by the National Fire Protection Association (NFPA). Such evaluations shall be conducted by: (3-28-23)
- i. A field evaluation body approved by the authority having jurisdiction. The field evaluation body shall meet minimum recognized standards for competency, such as NFPA 790 - Standard for Competency of Third-Party Field Evaluation Bodies, 2012 edition, published by the National Fire Protection Association (NFPA); or (3-28-23)
- ii. In the case of industrial machinery only, as defined by NFPA 79 - Electrical Standard for Industrial Machinery, 2012 edition, a field evaluation may be performed by a professional engineer currently licensed to practice electrical engineering by the state of Idaho and who is not involved in the design of the equipment being evaluated or the facility in which the equipment is to be installed. (3-28-23)
- c.** Availability of NFPA Standards. The most recent edition of NFPA 790 - Standard for Competency of Third-Party Field Evaluation Bodies and NFPA 791 - Recommended Practice and Procedures for Unlabeled Electrical Equipment Evaluation published by the National Fire Protection Association (NFPA) are available at the Division. (3-28-23)

(BREAK IN CONTINUITY OF SECTIONS)

501. – ~~999~~599. (RESERVED)

600. IDAHO ELECTRICAL CODE.

01. Documents. Under the provisions of Section 54-1001, Idaho Code, the National Electrical Code, 2023 Edition, (herein NEC) is amended as follows: ()

a. Sections 110.3(A) and 110.3(B). Shall not apply to submersible well pumps installed in swimming and marine areas; provided however, such articles shall apply to all other equipment required in the installation of a submersible well pump in such areas except for the actual submersible well pump itself. ()

b. Section 210.8(A). Delete reference to 250-volt receptacles. ()

c. Section 210.8(A)(5). Delete section 210.8(A) list item (5) and replace with the following: Unfinished areas of basements. ()

d. Section 210.8(A)(7) Areas with sinks and permanent provisions for food preparation, beverage preparation, or cooking. Delete section 210.8(A) list item (7). ()

e. Section 210.8(A)(8). Delete section 210.8(A) list item (8) and replace with the following: Sinks - located in areas other than kitchens where receptacles are installed within one and eight tenths (1.8) meters (six (6) feet) of the inside edge of the sink. ()

f. Section 210.8(A)(11). Delete section 210.8(A) list item (11) Laundry Areas. ()

g. Article 210.8(B). Delete list items (3), (4), and (14). ()

h. Section 210.8(B)(7). Delete section 210.8(B) list item (7) and replace with the following: Sinks - located in kitchens and any other area where receptacles are installed within one and eight tenths (1.8) meters (six (6) feet) of the outside edge of the sink. ()

i. Section 210.8(D). In dwelling units only, delete list items (7) Dishwashers, (8) Electric ranges, (9) Wall-mounted ovens, (10) Counter-mounted cooking units, (11) Clothes dryers, and (12) Microwave ovens. ()

j. Section 210.8(F). Delete list items (1) Garages that have floors that are located at or below grade level and (2) Accessory buildings. ()

k. Section 210.12(B). Shall apply in full. Exception: In one- and two-family dwelling units, Arc-Fault Circuit-Interrupter Protection shall only apply to all branch circuits and outlets supplying bedrooms. All other locations in such units are exempt from the requirements of section 210.12(B). ()

l. Section 210.52 (C) list items (3) and (4) - Island Countertop Spaces and Peninsular Countertop Spaces. If installed, receptacle outlets shall also be permitted to be mounted not more than 300 mm (12 in.) below the countertop or work surface. Receptacles mounted below a countertop or work surface in accordance with this exception shall not be located where the countertop or work surface extends more than 150 mm (6 in.) beyond its support base. ()

m. Section 210.52(E)(3). Delete section 210.52(E) list item (3) and replace with the following: Balconies, Decks, and Porches. Balconies, decks, and porches having an overall area of twenty (20) square feet or more that are accessible from inside the dwelling unit shall have at least one (1) receptacle outlet installed within the perimeter of the balcony, deck, or porch. The receptacle shall not be located more than two (2.0) meters (six and one half (6½) feet) above the balcony, deck, or porch surface. ()

n. Section 215.18(A)(1) Surge Protection. Delete section 215.18(A) list item (1). ()

o. Article 225.41 Emergency Disconnects. For one- and two-family dwelling units, an emergency disconnecting means shall be permitted when installed in compliance with sections 225.41(A), (B), and (C). ()

p. Section 225.42(A)(1) Surge Protection. Delete section 225.42(A) list item (1). ()

q. Section 230.67(A)(1) Surge Protection. Delete section 230.67(A) list item (1). ()

r. Article 230.85 Emergency Disconnects. For one- and two-family dwelling units, an emergency disconnecting means shall be permitted when installed in compliance with sections 230.85(A), (B), (D), and (E). Delete section 230.85(C). ()

s. Section 314.27(C) Boxes at Ceiling-Suspended (Paddle) Fan Outlets. Delete second paragraph. ()

t. Section 334.10(3). Delete and replace with the following: Other structures permitted to be of Types III, IV, and V construction. Cables shall be concealed within walls, floors, or ceilings that provide a thermal barrier of

material that has at least a fifteen (15) minute finish rating as identified in lists of fire-rates assemblies. For the purpose of this section, cable located in attics and underfloor areas that are not designed to be occupied shall be considered concealed. ()

u. Section 334.15(C). Where the height of a crawl space does not exceed one and four tenths (1.4) meters or four and one half (4.5) feet, it shall be permissible to secure NM cables, that run at angles with joist, to the bottom edge of joist. NM cables that run within two and one tenth (2.1) meters or seven (7) feet of crawl space access shall comply with article 320.23. ()

v. Pole Lighting. Poles used as lighting standards along roadways only (parking areas are not roadways) that are forty (400 feet or less in nominal height and that support no more than four (4) luminaries operating at a nominal voltage of three hundred (300) volts or less to the ground, shall not be considered a structure as it is defined as equipment by the NEC. The disconnecting means may be mounted to the pole or elsewhere in accordance with NEC, section 225.31(B), exception 3. Special purpose fusible connectors (model SEC 1791-DF or model SEC 1791-SF) or equivalent shall be installed in a listed handhole (underground) enclosure. The enclosure shall be appropriately grounded and bonded per the requirements of the NEC applicable to article 230 – Services. Overcurrent protection shall be provided by a (fast-acting – minimum 100K RMS Amps 600 VAC) rated fuse. Wiring within the pole for the luminaries shall be protected by supplementary overcurrent device (time -delay – minimum 10K RMS Amps 600 VAC) in break-a-away fuse holder accessible from the handhole. Any poles supporting or incorporating utilization equipment or exceeding the prescribed number of luminaries, or in excess of forty (40) feet, may be considered structures, and an appropriate service disconnecting means shall be required per the NEC. All luminaire – supporting poles shall be appropriately grounded and bonded per the NEC. A service may not need a Watt Hour Meter. ()

w. Section 422.5(A)(7). Delete section 422.5(A) list item (7) dishwashers. ()

x. Section 675.8(B). Compliance with section 675.8(B) shall include the additional requirement that a disconnecting means always be provided at the point of service them the utility no matter where the disconnecting means for the machine is located. ()

y. Article 682.10. Shall not apply to submersible well pumps installed in swimming and marine areas; provided however, such articles shall apply to all other equipment required in the installation of a submersible well pump in such areas except for the actual submersible well pump itself. ()

z. Article 682.11. Add the following exception: This article shall not apply to service equipment that is located on or at the dwelling unit and which is not susceptible to flooding. ()

aa. Article 682.13. Add the following exceptions: ()

i. Exception No. 1. Wiring methods such as HDPE schedule eighty (80) conduit or its equivalent or greater and clearly marked at a minimum “Caution Electrical” to indicate that it contains electrical conductors shall be approved. It shall be buried wherever practical, and in accordance with the requirements of the authority having jurisdiction. The use of gray HDPE water pipe rated at two hundred (200) PSI (e.g. SIDR-7 or DR-9) is suitable for use as a chase only when the following conditions are met: when internal conductors are jacketed submersible pump cable; when used in continuous lengths, directly buried, or secured on a shoreline above and below the water line; when submersible pump wiring terminations in the body of water according to section 682.13 Exception No. 2 are met. ()

ii. Exception No. 2. Any listed and approved splices required to be made at the submersible well pump itself, outside of a recognized submersed pump sleeve or housing, when wires are too large to be housed inside such sleeve, shall be covered with a non-metallic, impact resistant material, no less than one quarter (.25) inches thick, such as heavy-duty heat shrink or other equivalent method approved by the authority having jurisdiction. (e.g. install a heat shrink over the sleeve or housing that the submersible well pump is installed in, and then recover (apply heat) the heat shrink over both the HDPE and the water line). At least six (6) inches shall be over the sleeve and at least twelve (12) inches over the HDPE and water line. ()

iii. Exception No. 3. Pipe, conduit, PVC well casing, or other electrically unlisted tubing may be used

as a chase, but not as a raceway, to protect conductors or cables from physical damage. Conductors or cables within a chase shall be rated for the location. ()

bb. Article 682.14. Add the following additional exception: For installations of submersible well pumps installed in public swimming and marine areas, submersible well pumps shall be considered directly connected and shall be anchored in place. Ballast is an acceptable form of anchoring. ()

cc. Section 682.14(A). Add the following exception: For installations of submersible well pumps installed in public swimming and marine areas, motor controller circuits such as remotely located stop pushbutton/s, disconnect/s, relay/s or switches shall be permitted as a required disconnecting means. Such circuits shall be identified at a minimum as “Emergency Pump Stop”, or “Emergency Stop” with other obvious indications on the visible side of the enclosure, that it controls a submersible pump in the body of water. ()

dd. Article 682.15. Add the following exceptions: ()

i. Exception No. 1. Submersible pumps, and their motor leads, located in bodies of water, and that are rated sixty (60) amperes maximum, two hundred fifty (250) volts maximum of any phase, shall have GFCI or Ground Fault Equipment Protection designed to trip at a maximum of thirty (30) milliamps or less, protected by means selected by a licensed installer, meeting listing or labeling requirements, and inspected by the AHJ prior to submersion in bodies of water. ()

ii. Exception No. 2. Installations or repair and replacement of submersible pumps located in bodies of water, that are rated over sixty (60) amperes, and rated at any voltage, shall be evaluated by a qualified designer or experienced licensed contractor, or involve engineering or be engineered, for each specific application, with the goal of public safety. Whenever possible, GFCI or Ground Fault Equipment Protection designed to trip at a maximum of thirty (30) milliamps or less, meeting listing or labeling requirements, shall be installed, and inspected by the AHJ prior to submersion in bodies of water. Article 690.12 Rapid Shut Down. Add following Exemptions: ()

iii. Detached structures whose sole purpose is to house PV system equipment shall not be subject to the requirements outlined in article 690.12. ()

iv. PV system circuits installed on or in buildings without the presence of a utility supplied power source shall not be required to comply with article 690.12 where all of the following apply: the minimum distance to bring electric utility power lines or service conductors to the building is 1,000 feet or greater; the building has a minimum setback distance of 100 feet from any building or structure located on adjacent properties; A lockable service entrance rated AC disconnect is installed outside at a readily accessible location; and the AC disconnect has a permanent placard or label with the following words or equivalent: ()

WARNING

SOLAR PV SYSTEM IS NOT EQUIPPED WITH RAPID SHUTDOWN

The warning placard or label shall comply with Section 110.21(B).

ee. Section 690.12(A) Exception. PV system circuits originating within or from arrays not attached to buildings that terminate on the exterior of buildings or inside nearest the point of entrance, and PV system circuits installed in accordance with article 230.6 shall not be considered controlled conductors for the purposes of this section. ()

ff. Article 706.5: Listing. Energy storage systems shall be listed. This shall not apply to lead-acid batteries. ()

gg. Section 706.15(B) Off Grid Systems. Add the following exception: For one-family and two-family dwellings, a disconnecting means or its remote control shall be located at a readily accessible location. ()

02. Availability. A copy of the 2023 National Electrical Code is available at the offices of the Division of Occupational and Professional Licenses. ()

601. – 999. (RESERVED)

IDAPA 26 – DEPARTMENT OF PARKS AND RECREATION
26.01.37 – RULES GOVERNING TEST PROCEDURES AND INSTRUMENTS
FOR NOISE ABATEMENT OF OFF HIGHWAY VEHICLES
DOCKET NO. 26-0137-2401 (ZBR CHAPTER REPEAL)
NOTICE OF RULEMAKING – PROPOSED RULE

AUTHORITY: In compliance with Section 67-5221(1), Idaho Code, notice is hereby given that this agency has initiated proposed rulemaking procedures. The action is authorized pursuant to Sections 67-4223, 67-4249, and 67-7125 Idaho Code.

PUBLIC HEARING SCHEDULE: Public hearing(s) concerning this rulemaking will be scheduled if requested in writing by twenty-five (25) persons, a political subdivision, or an agency, not later than October 16, 2024.

The hearing site(s) will be accessible to persons with disabilities. Requests for accommodation must be made not later than five (5) days prior to the hearing, to the agency address below.

DESCRIPTIVE SUMMARY: The following is a nontechnical explanation of the substance and purpose of the proposed rulemaking:

The Idaho Department of Parks and Recreation is proposing to repeal this chapter and place it in Idaho statute.

FEE SUMMARY: The following is a specific description of the fee or charge imposed or increased: N/A.

FISCAL IMPACT: The following is a specific description, if applicable, of any negative fiscal impact on the state General Fund greater than ten thousand dollars (\$10,000) during the fiscal year resulting from this rulemaking: None.

NEGOTIATED RULEMAKING: Pursuant to Section 67-5220(1), Idaho Code, negotiated rulemaking was conducted. The Notice of Intent to Promulgate Rules - Negotiated Rulemaking was published in the August 07, 2024, Idaho Administrative Bulletin, [Volume 24-8 page 183](#).

INCORPORATION BY REFERENCE: Pursuant to Section 67-5229(2)(a), Idaho Code, the following is a brief synopsis of why the materials cited are being incorporated by reference into this rule: N/A

ASSISTANCE ON TECHNICAL QUESTIONS, SUBMISSION OF WRITTEN COMMENTS: For assistance on technical questions concerning the proposed rule, contact Seth Hobbs, (208) 514-2427, seth.hobbs@idpr.idaho.gov.

Anyone may submit written comments regarding this proposed rulemaking. All written comments must be directed to the undersigned and must be delivered on or before October 23, 2024.

DATED this 19th day of September, 2024.

Seth Hobbs
Idaho Department of Parks and Recreation
5657 Warm Springs Ave.
Boise, ID 83716
Phone: (208) 514-2427

IDAPA 26.01.37 IS PROPOSED TO BE REPEALED IN ITS ENTIRETY.

IDAPA 31 – IDAHO PUBLIC UTILITIES COMMISSION

31.21.01 – CUSTOMER RELATIONS RULES FOR GAS, ELECTRIC, AND WATER PUBLIC UTILITIES (THE UTILITY CUSTOMER RELATIONS RULES)

DOCKET NO. 31-2101-2401

NOTICE OF RULEMAKING – ADOPTION OF PENDING RULE

EFFECTIVE DATE: This rule has been adopted by the agency and is now pending review by the 2025 Idaho State Legislature and must be approved by concurrent resolution of the Legislature to go into effect, in accordance with Section 67-5224(2)(c), Idaho Code. Should the pending rule be approved, it will become final and effective on July 1, 2025, in the year of the First Regular Session of the Sixty-eighth Idaho Legislature, unless the concurrent resolution states a different effective date.

AUTHORITY: In compliance with Section 67-5224, Idaho Code, notice is hereby given that this agency has adopted a pending rule. The action is authorized pursuant to Section(s) General legal authority of the Public Utilities Law, Chapters 1 through 7, Title 61, Idaho Code, and the specific legal authority of Sections 61-301, 61-302, 61-303, 61-315, 61-503, 61-507, and 61-520, Idaho Code.

DESCRIPTIVE SUMMARY: The following is a concise explanatory statement of the reasons for adopting the pending rule and a statement of any change between the text of the proposed rule and the text of the pending rule with an explanation of the reasons for the change:

During last Session’s committee hearing it was requested the Idaho Public Utilities Commission make a change in IDAPA 31.21.01.304.02 (Rule 304) for this Legislature’s review; change the word “may” to “shall” in Rule 304.

There are no changes to the pending rule, and it is being adopted as originally proposed. The complete text of the proposed rule was published in the August 7, 2024 Idaho Administrative Bulletin, [Vol. 24-8, pages 185-186](#).

FEE SUMMARY: Pursuant to Section 67-5224(2)(d), Idaho Code, a pending fee rule shall not become final and effective unless affirmatively approved by concurrent resolution of the Legislature. The following is a description of the fee or charge imposed or increased in this rulemaking: N/A.

FISCAL IMPACT: The following is a specific description, if applicable, of any negative fiscal impact on the state General Fund greater than ten thousand dollars (\$10,000) during the fiscal year: N/A.

ASSISTANCE ON TECHNICAL QUESTIONS: For assistance on technical questions concerning this pending rule, contact Stephen Goodson at (208) 334-0323.

DATED this 30th day of August, 2024.

Monica Barrios-Sanchez, Commission Secretary
Idaho Public Utilities Commission
11331 W. Chinden Blvd., Bldg. 8, Ste 201-A
Boise, ID 83714
P.O. Box 83720
(208) 334-0323 Office
(208) 334-4045 Fax

IDAPA 31 – IDAHO PUBLIC UTILITIES COMMISSION

31.41.01 – CUSTOMER RELATIONS RULES FOR TELEPHONE CORPORATIONS PROVIDING SERVICES IN IDAHO SUBJECT TO CUSTOMER SERVICE REGULATION BY THE IDAHO PUBLIC UTILITIES COMMISSION

(THE TELEPHONE CUSTOMER RELATIONS RULES)

DOCKET NO. 31-4101-2401 (ZBR CHAPTER REWRITE)

NOTICE OF RULEMAKING – PROPOSED RULE

AUTHORITY: In compliance with Section 67-5221(1), Idaho Code, notice is hereby given that this agency has initiated proposed rulemaking procedures. The action is authorized pursuant to the General legal authority of the Public Utilities Law, Chapters 1 through 7, Idaho Code, and the specific legal authority of Sections 61-301, 61-302, 61-303, 61-315, 61-503, 61-507, 62-605, 62-606, 62-612, 62-616, and 62-622, Idaho Code, with regard to service.

PUBLIC HEARING SCHEDULE: Public hearing(s) concerning this rulemaking will be scheduled if requested in writing by twenty-five (25) persons, a political subdivision, or an agency, not later than October 16, 2024.

The hearing site(s) will be accessible to persons with disabilities. Requests for accommodation must be made not later than five (5) days prior to the hearing, to the agency address below.

DESCRIPTIVE SUMMARY: The following is a nontechnical explanation of the substance and purpose of the proposed rulemaking:

The Idaho Public Utilities Commission initiated this rulemaking in compliance with [Executive Order No. 2020-01: Zero-Based Regulation](#), issued by Governor Little on January 16, 2020. The goal of the rulemaking is to perform a critical and comprehensive review of the entire chapter in an attempt to reduce overall regulatory burden, streamline various provisions, and increase clarity and ease of use.

FEE SUMMARY: The following is a specific description of the fee or charge imposed or increased: N/A.

FISCAL IMPACT: The following is a specific description, if applicable, of any negative fiscal impact on the state General Fund greater than ten thousand dollars (\$10,000) during the fiscal year resulting from this rulemaking: N/A.

NEGOTIATED RULEMAKING: Pursuant to Section 67-5220(1), Idaho Code, negotiated rulemaking was conducted. The Notice of Intent to Promulgate Rules - Negotiated Rulemaking was published in the August 7, 2024 Idaho Administrative Bulletin, [Vol. 24-8, pages 187-188](#).

INCORPORATION BY REFERENCE: Pursuant to Section 67-5229(2)(a), Idaho Code, the following is a brief synopsis of why the materials cited are being incorporated by reference into this rule: Slamming regulations promulgated by the Federal Communications Commission, 47 CFR 1100 through 1170 and 64.1190 (October 1, 2011).

ASSISTANCE ON TECHNICAL QUESTIONS, SUBMISSION OF WRITTEN COMMENTS: For assistance on technical questions concerning the proposed rule, contact Stephen Goodson (208) 334-0323. Anyone may submit written comments regarding this proposed rulemaking. All written comments must be directed to the undersigned and must be delivered on or before October 23, 2024.

DATED this 30th day of August, 2024.

Monica Barrios-Sanchez, Commission Secretary
Idaho Public Utilities Commission
11331 W. Chinden Blvd., Bldg. 8, Ste 201-A
Boise, ID 83714
P.O. Box 83720
(208) 334-0323 Office
(208) 334-4045 Fax

THE FOLLOWING IS THE PROPOSED TEXT OF DOCKET NO. 31-4101-2401
(ZBR Chapter Rewrite)

31.41.01 – CUSTOMER RELATIONS RULES FOR TELEPHONE CORPORATIONS
PROVIDING SERVICES IN IDAHO SUBJECT TO CUSTOMER SERVICE REGULATION
BY THE IDAHO PUBLIC UTILITIES COMMISSION

(THE TELEPHONE CUSTOMER RELATIONS RULES)

000. LEGAL AUTHORITY (RULE 0).

~~These rules are adopted under the general legal authority of the Public Utilities Law, Chapters 1 through 7, Title 61, Idaho Code, and the Telecommunications Act of 1988, Chapter 6, Title 62, Idaho Code, and the specific authority of Sections 61-301, 61-302, 61-303, 61-315, 61-503, 61-507, 61-520, 62-605, 62-606, 62-612, 62-616, and 62-622, Idaho Code, with regard to service.~~ (3-31-22)()

001. TITLE AND SCOPE (RULE 1).

~~The name of this chapter is the “Customer Relations Rules for Telephone Corporations Providing Services in Idaho Subject to Customer Service Regulation by the Idaho Public Utilities Commission,” (The Telephone Customer Relations Rules). For companies subject to Commission regulation under Title 62, Idaho Code, these rules apply to companies providing local exchange service as defined in Section 62-603, Idaho Code. This chapter has the following scope: These rules provide a set of fair, just, reasonable, and non-discriminatory rules to address recurring areas of disagreement between local exchange companies and other telephone companies and customers with regard to deposits, guarantees, billing, application for service, denial of service, termination of service, complaints to telephone companies, billing for interrupted service, and provision of certain information about customers to authorities.~~ (3-31-22)()

002. WRITTEN INTERPRETATIONS—AGENCY GUIDELINES (RULE 2).

~~Written interpretations to these rules can be obtained from the Secretary of the Idaho Public Utilities Commission and are available from the office of the Commission Secretary.~~ (3-31-22)

003. ADMINISTRATIVE APPEALS (RULE 3).

~~This rule governs formal complaints and requests for exemption under these rules. Any telephone company or customer requesting and receiving an informal staff determination with regard to a complaint may formally request the Commission to review the staff’s determination. If unusual hardships result from the application of any of these rules, any telephone company or customer may apply to the Commission for, or the Commission on its own motion may order, a permanent or temporary exemption. A formal complaint or request for exemption must be filed with the Commission pursuant to the Commission’s Rules of Procedure, IDAPA 31.01.01.000 et seq.~~ (3-31-22)

002. -- 003. (RESERVED)

004. (RESERVED) INCORPORATION BY REFERENCE (RULE 4).

01. 47 CFR 1100 through 1170 and 64.1190 (October 1, 2011), with the following modifications: ()

a. Form. Complaints regarding an unauthorized carrier change may be filed with the Commission in person, by mail, by e-mail, or by telephone. E-mail complaint forms to secretary@puc.idaho.gov. A copy of the telephone bill(s) in dispute and other relevant evidence shall be provided to the Commission by the complaining party. The slamming complaint shall include the following information: ()

i. Name, address and telephone number of complainant: ()

- ii. Name/identity of the alleged slamming carrier: ()
- iii. Name of the previous authorized carrier: ()
- iv. Name of the billing entity: ()
- v. Date the alleged slamming occurred: ()
- vi. Whether the customer has been restored to the preferred carrier: ()
- vii. Whether the customer has paid any or all of the disputed charges: ()
- viii. Efforts in attempting to resolve the alleged slamming; and ()
- ix. Whether the customer was charged for changing carrier(s). ()

005. DEFINITIONS (RULE 5).

The following definitions are used in this title and chapter: (3-31-22)

01. Customer. A “customer” is a person or entity who has requested service or currently receives service from a telephone company or has assumed responsibility for payment of service provided to another person or entity. Any person whose service has been temporarily disconnected for non-payment will continue to be a “customer” for the purposes of these rules until such time as service is permanently disconnected. (3-31-22)

~~**02. Local Exchange Company (LEC).** “Local exchange company” (LEC) is a telephone company providing local exchange service to end users. (3-31-22)~~

~~**03. Message Telecommunications Service (MTS).** “MTS” (commonly known as “long distance service”) means the transmission of two way interactive switched voice communication between local exchange areas. (3-31-22)~~

04. Other Services. “Other services” mean all services except local exchange and MTS services provided, billed, or collected by a telephone company. (3-31-22)

~~**05. Residential Service.** “Residential service” means telecommunication service furnished and maintained at a dwelling primarily for personal or domestic purposes and not for business, professional or institutional purposes, i.e., service provided to residential customers as defined in Section 62-603(9), Idaho Code. (3-31-22)~~

~~**06. Small Business Service.** “Small business service” means telecommunication service furnished to a business or institutional entity, whether an individual, partnership, corporation, association or other business or institutional form, for occupational, professional, or institutional purposes, to customers who do not subscribe to more than five (5) local access lines which are billed to a single billing location, i.e., service provided to small business customers as defined in Section 62-603(11), Idaho Code. (3-31-22)~~

07. Telephone Company. Unless further restricted by definition within a rule or a group of rules, “telephone company” means any entity subject to this Commission’s regulation as a provider of telecommunication services to end-users under the Public Utilities Law (Idaho Code, Title 61, Chapters 1-7) or subject to this Commission’s authority under the Telecommunications Act of 1988, as amended, (Idaho Code, Title 62, Chapter 6) or the federal Telecommunications Act of 1996 (47 U.S.C. 151 et seq). (3-31-22)

006. -- 007. (RESERVED)

008. EXERCISE OF RIGHTS BY CUSTOMER (RULE 8).

Telephone company will not discriminate against or penalize a customer for exercising any right granted by these rules. (3-31-22)

~~009. **INFORMAL COMPLAINTS AND INTERPRETATION OF RULES (RULE 9).**~~

~~Commission staff may informally interpret these rules and tariffs or other filings of telephone companies and investigate complaints made to the Commission. The Commission may issue orders interpreting these rules, telephone company tariffs or similar filings, and resolving formal complaints. (3-31-22)~~

009. (RESERVED)

010. CONFLICT WITH TELEPHONE TARIFFS OR PRICE LISTS (RULE 10).

If a telephone company's tariff or price list denies or restricts customer rights protected by these rules, these rules supersede conflicting tariff or price list provisions. (3-31-22)

~~011. **INCORPORATION BY REFERENCE — CODE OF FEDERAL REGULATIONS (RULE 11).**~~

~~Rules 701 through 703 incorporate by reference federal regulations issued by the Federal Communications Commission. The incorporated regulations are found in the Code of Federal Regulations available from the U.S. Government Printing Office. Incorporated materials are also available for inspection and copying at the offices of the Public Utilities Commission. (3-31-22)~~

~~012. -- 099. (RESERVED)~~

RESIDENTIAL AND SMALL BUSINESS DEPOSIT
Rules 100 through 199

100. DEPOSIT REQUIREMENTS -- LECS (RULE 100).

01. Residential Customers. Telephone companies providing local exchange service will not demand or hold any deposit from any residential customer for service without proof that the customer is likely to be a credit risk or to damage the property of the local exchange company or other companies for which it bills. A history of late payment or lack of previous history with the local exchange company does not, in itself, constitute such proof. A local exchange company will not demand or hold a deposit under this rule as a condition of service from a residential customer unless one (1) or more of the following criteria applies: (3-31-22)

a. The customer has outstanding a prior residential service account and at the time of application for service remains unpaid and not in dispute. (3-31-22)

b. The customer's service has been temporarily denied or terminated within the past four (4) years for one (1) or more of the following reasons: (3-31-22)

i. Non-payment of any undisputed delinquent bill; (3-31-22)

ii. Obtaining, diverting or using telephone service without the authorization or knowledge of the telephone company. (3-31-22)

c. The customer does not have verifiable previous telephone service that was in existence for a period exceeding twelve (12) months and does not pass an objective credit screen. (3-31-22)

d. The telephone company has determined that information provided by the customer is materially false or materially misrepresents the customer's true status. (3-31-22)

e. The customer requests service at a residence where a prior subscriber still resides and where any balance for service to that prior subscriber incurred at that location is past due or owing. (3-31-22)

02. Small Business Customers. Telephone companies providing local exchange service will not demand or hold any deposit as a condition of service from any current small business customer for small business service unless one (1) or more of the following criteria apply: (3-31-22)

a. Any of the conditions listed in Rule 100.01 of this rule are present. (3-31-22)

- b. The customer has not had previous service with that telephone company. (3-31-22)
- c. The customer was delinquent in payment two (2) or more times in the previous twelve (12) months. (3-31-22)

03. Bankrupt Customers. If a customer, either residential or a small business, has sought any form of relief under the Federal Bankruptcy Laws, has been brought within the jurisdiction of the bankruptcy court for any reason in an involuntary manner, or has had a receiver appointed in a state court proceeding, then a deposit may be demanded as allowed by the Federal Bankruptcy Laws. (3-31-22)

101. OTHER DEPOSIT STANDARDS PROHIBITED (RULE 101).

A local exchange company will not require a deposit or other guarantee as a condition of new or continued residential telephone service ~~based upon residential ownership or location, income level, source of income, employment tenure, nature of occupation, race, creed, sex, age, national origin, marital status, number of dependents, or any other criterion not authorized by these rules. Rules governing deposits will be applied uniformly~~ except as expressly authorized by these rules. If the customer, either residential or small business, selects another company to provide services and arranges to be billed directly by that company rather than through the local exchange company, no deposit may be collected by the local exchange company for the services provided by the other company. (3-31-22)()

102. EXPLANATION FOR DENIAL OF SERVICE OR REQUIREMENT OF DEPOSIT -- LECS (RULE 102).

If the local exchange company requires a deposit as a condition of providing service, then it will immediately provide an explanation to the customer why a deposit is required. The customer will be given an opportunity to rebut these reasons. The notice will also advise the customer that if there is a dispute an informal or formal complaint may be filed with the Commission. (3-31-22)

103. AMOUNT OF DEPOSIT -- LECS (RULE 103).

A deposit allowed pursuant to Rule 100 as a condition of service by a local exchange company must not exceed two (2) months' charges for local exchange service. Additional deposits for damage or other reasons independent of usage may be in reasonable amounts. (3-31-22)

104. INTEREST ON DEPOSITS (RULE 104).

01. Interest Payable. Interest will be payable on the deposited amounts at the rate provided by Rule 104.02. Interest will accrue from the date the deposit is made until the deposit is refunded or applied to the customer's bill; however, interest will not accrue on a deposit if: (3-31-22)

a. Service is terminated temporarily at the request of the customer who leaves the deposit with the telephone company for future use as a deposit; or (3-31-22)

b. Service has been permanently terminated and the telephone company has been unsuccessful in its attempt to refund a deposit. (3-31-22)

02. Interest Rate. On or before November 15 of each year, the Commission will determine the twelve-month average interest rate for one-year Treasury Bills for the previous November 1 through October 31, round that rate to the nearest whole percent, and notify the telephone companies of its determination of this interest rate. That rate will be in effect for the following calendar year for all deposits described in Rule 104.01. (3-31-22)

105. RETURN OF DEPOSIT -- LECS (RULE 105).

01. Former Customers. Upon termination of service the telephone company will credit the deposit, ~~(with accrued interest)~~, to the final bill then promptly return any remaining balance to the customer. (3-31-22)()

02. Existing Customers. If the customer has paid all undisputed bills and has no more than one (1) late payment during the past twelve (12) consecutive months of service, the telephone company will promptly return the deposit, ~~(with accrued interest)~~ by crediting the customer's current account or issuing a refund. (3-31-22)()

03. Retention During Dispute. The local exchange company may retain the deposit pending resolution of a dispute over termination of service. If the deposit is later refunded to the customer, the local exchange company will pay interest at the annual rates established in Rule 104 for the entire period over which the deposit was held. (3-31-22)

04. Early Return of Deposit. A local exchange company may refund a deposit plus accrued interest in whole or part at any time before the time prescribed in this rule. (3-31-22)

106. TRANSFER OF DEPOSIT AND OUTSTANDING BALANCE (RULE 106).

Deposits will not be transferred from one (1) customer to another customer or between classes of service, except at the customer's request. When a customer with a deposit on file transfers service to a new location within the same telephone company's service area in Idaho, the deposit and any outstanding balance will be transferred to the account for the new location. (3-31-22)()

107. RECORDS OF DEPOSITS (RULE 107).

01. Receipts. Each customer paying a deposit will be provided the following information: (3-31-22)

a. Name of customer and service address for which deposit is held; (3-31-22)

b. Date of payment; (3-31-22)

c. Amount of payment; and (3-31-22)

d. Terms and conditions governing the return of deposits. (3-31-22)

~~**02. Retention of Records.** Each telephone company will maintain records that will enable a customer entitled to a return of a deposit to obtain a refund even though the customer may be unable to produce the receipt for the deposit. These records must include the name of each customer, the service location(s) and telephone number(s) of the customer while the deposit is retained, and the date(s) and amount(s) of the deposits. The telephone company will retain records of deposits that have been refunded to customers for a period of three (3) years after the date of refund. The telephone company will retain records of unclaimed deposits for a period of seven (7) years as required by Section 14-531, Idaho Code. (3-31-22)~~

~~**03. Transfer of Records.** Upon the sale or transfer of any telephone company or any of its operating units, the seller will certify to the Commission that it has a list showing the names of all customers whose service is transferred and who have a deposit on file, the date the deposit was made and the amount of the deposit. (3-31-22)~~

~~**108. UNCLAIMED DEPOSITS AND ADVANCE PAYMENTS (RULE 108).**~~

~~**01. Presumption of Abandonment.** Pursuant to Section 14-508, Idaho Code, any deposit or advance payment made to obtain or maintain local exchange service or other services that is unclaimed by the owner for more than one (1) year after termination of service is presumed abandoned. (3-31-22)~~

~~**02. Financial Assistance Program.** A telephone company may apply to the Commission for approval to pay unclaimed deposits and advance payments presumed to be abandoned to a financial assistance program which assists the telephone company's low income and disadvantaged customers with payment of utility bills. The telephone company will file its report of such abandoned property as required by Section 14-517, Idaho Code, and retain records as required by Section 14-531, Idaho Code. (3-31-22)~~

~~**109.** -- 199. (RESERVED)~~

BILLING
Rules 200 through 299

200. FURTHER DEFINITION (RULE 200).

As used in Rules 201 through 205, “bill” or “billing statement” refers to a written request for payment listing charges for goods and services that is mailed or otherwise delivered to the customer for payment. A billing statement may be provided to the customer in an electronic format with the customer’s consent. Oral notice of the amount of charges pending is not a bill. Bills include requests for payments for services rendered by other telephone companies or other entities that are not telephone companies. This rule does not apply to billings between or among telephone companies. (3-31-22)

201. ISSUANCE OF BILLING STATEMENTS -- CONTENTS OF BILLS -- RESIDENTIAL AND SMALL BUSINESS SERVICE (RULE 201).

01. Local Exchange Service. Billing statements for residential and small business local exchange service will be regularly issued and must contain the following information: (3-31-22)

- a.** The date the billing statement is issued; (3-31-22)
- b.** The time period covered by the billing statement; (3-31-22)
- c.** The due date by which payment must be received; unless the customer has authorized automatic monthly payment. If automatic payment is authorized, the customer must be informed in writing when funds will be withdrawn from a bank account or charged to a credit card account. In addition, the billing statement must state the actual or earliest possible date that funds will be withdrawn or the credit card charged unless the customer consents otherwise in writing at the time automatic payment is authorized; (~~3-31-22~~)()
- d.** Any amounts transferred from another account; (3-31-22)
- e.** Any amounts past due; (3-31-22)
- f.** Any payments or credits applied to the customer’s account since the last bill; (3-31-22)
- g.** The total amount due; (3-31-22)
- h.** Names of all telephone companies or entities providing goods and services for which the customer is billed, sufficient information to readily identify the goods and services provided, and the amounts charged; (3-31-22)
- i.** The toll-free telephone number(s) available to customers for answering inquiries and resolving complaints about goods and services billed; (3-31-22)
- j.** An itemization of charges for goods and services provided to the customer and any associated fees, taxes, surcharges or subscriber line charges. Charges for each good or service provided as part of a package under a single price, or calling plans in which individual calls are billed at a flat rate regardless of usage need not be separately itemized. (3-31-22)

02. MTS Bills. In addition to the requirements of Rule 201.01, bills for MTS service must identify the number called and the date, time, duration, destination and charge for each call, unless the customer has selected a flat rate calling plan. For collect and third-party calls, the MTS provider must also itemize the origin of the call. (~~3-31-22~~)()

03. Other Services. No telephone company may send demand letters or initiate collection efforts for any amount owed by a customer who subscribes to or is billed for services other than local exchange service and MTS services provided by another telephone company unless the bill separately lists those services as required by this rule. (3-31-22)

04. Customer Request for Less Detail. Upon customer request, telephone companies may provide billing statements containing less detail than required by this rule. Telephone companies must make available without charge detailed billing information for the preceding twelve (12) months to those customers who have elected to receive less detail on monthly billing statements but subsequently request more detail. (3-31-22)

202. DUE DATE OF BILLS -- DELINQUENT BILLS (RULE 202).

The telephone company may require that bills for service be paid within a specified time after the billing date. The minimum specified time after the billing date is fifteen (15) days (or twelve (12) days after mailing or delivery of a paper or electronic bill, if bills are mailed or delivered more than three (3) days after the billing date). Upon the expiration of this time without payment, the bill may be considered delinquent. With the customer's approval, automatic monthly payments made by withdrawal from a bank account or charged to a credit card account may take place prior to the normal due date if the customer has authorized such a payment. (3-31-22)

203. BILLING ERRORS, BILLING UNDER INCORRECT RATES, OR FAILURE TO BILL (RULE 203).

01. Billing Errors -- Failure to Bill. Whenever the billing for telephone service was not accurately billed because of malfunction in billing equipment or error in preparation of bills, the telephone company shall prepare a corrected billing. If the telephone company has not billed a customer for service provided, the telephone company shall prepare a bill for the period in which service was provided and the customer was not billed. At its discretion, the telephone company may waive rebilling for undercharges. (3-31-22)

02. Billing Under Incorrect Rates. A customer has been billed under an incorrect rate if the customer was billed under a rate for which the customer was not eligible or the customer, who is eligible for billing under more than one (1) rate, was billed under a rate contrary to the customer's election or the election was made based upon erroneous information provided by the telephone company. If a customer is billed under an incorrect rate, the telephone company must recalculate the customer's past bills and correctly calculate future bills based on the appropriate rate. The telephone company is not required to adjust bills when it has acted in good faith based upon information provided by the customer. (3-31-22)

03. Rebilling Time Period. (3-31-22)

a. If the time when the billing error, billing under incorrect rates, or failure to bill (collectively referred to as "billing problem") began cannot be reasonably determined to have occurred within a specified billing period, the corrected billings will not exceed the most recent six (6) months before the discovery of the billing problem. (3-31-22)

b. If the time when the billing problem began can be reasonably determined, and the telephone company determines the customer was overcharged, the corrected billings will go back to that time, ~~but not to exceed three (3) years from the time the billing problem occurred~~ as provided by Section 61-642, Idaho Code. (3-31-22) ()

c. If the time when the billing problem began can be reasonably determined and the telephone company determines the customer was undercharged, the company may rebill for a period of six (6) months unless a reasonable person should have known of the inaccurate billing, in which case the rebilling may be extended for a period not to exceed three (3) years. The telephone company is responsible for identifying customers who have not been billed or who have been inaccurately billed. (3-31-22)

04. Refunds. The telephone company will promptly calculate refund amounts overpaid by the customer and issue a credit within two (2) billing cycles. Any remaining credit balance will be credited against future bills unless the customer, after notice from the telephone company, requests a refund and the amount is more than twenty-five dollars (\$25). The telephone company will advise the customer of the option to have any remaining credit balance exceeding twenty-five dollars (\$25) refunded. (3-31-22)

05. Additional Payments. The telephone company will promptly prepare a corrected billing for a customer who has been undercharged, indicating the amount owed to the company. An unbilled or undercharged customer will be given the opportunity to make payment arrangements under Rule 310 on the amount due. At the customer's option, the term of the payment arrangement may extend for the length of time that the underbilling accrued or the customer was not billed. (3-31-22)

204. BILLING PROHIBITED -- BILLING DISPUTES (RULE 204).

01. Unauthorized Charges. No telephone company will bill for unanswered or unaccepted telephone calls, telephone calls placed to a toll-free number, or telephone service or other goods and services not ordered or otherwise authorized by the customer of record. A telephone company that unknowingly submits a bill containing charges for unanswered or unaccepted telephone calls, telephone calls placed to a toll-free number, or telephone service or other services or goods not ordered or otherwise authorized by the customer of record shall be considered in violation of this rule unless the disputed amounts are removed from the customer's bill within two (2) billing cycles of the customer's notification to the company. (3-31-22)

02. Billing Disputes. A telephone company that bills and collects for other telephone companies or entities is responsible for either addressing billing disputes regarding unauthorized goods and services for which it bills or advising customers how to contact the providers of those goods and services. If a customer is unable to either contact or successfully resolve a dispute about unauthorized goods and services for which the telephone company bills, a credit equal to the disputed charges must be applied to the customer's account within two (2) billing cycles of the customer's notification to the company. (3-31-22)

205. RESPONSIBILITY FOR PAYMENT OF RESIDENTIAL SERVICE BILLS (RULE 205).

01. Customer Defined. For purposes of this rule, "customer" means a person whose name appears on the telephone company's regular bill for residential service or who signed a written application for residential service or another document informing the customer that he or she was assuming an obligation for payment of service. (3-31-22)

~~**02. Customer's Responsibility.** A telephone company will not hold a customer responsible for paying an amount not billed for the customer's own service or through use of the customer's own credit or facilities and whose own name does not appear on the current bill or application for service, unless: (3-31-22)~~

~~**a.** The customer expressly accepts responsibility for payment of the other person's bill; or (3-31-22)~~

~~**b.** The customer has a legal obligation to pay the other person's bill. (3-31-22)~~

~~**03. Customer Notice.** The telephone company will provide written notice of its intent to add to the customer's bill for current service an amount owed for another person's bill or service rendered at a former service location, if the lapse in service exceeds sixty (60) calendar days. The notice may be provided in an electronic format with the customer's consent. (3-31-22)~~

~~**04. Contents of Notice.** The notice must include: (3-31-22)~~

~~**a.** The name of the customer of record who owes the bill; (3-31-22)~~

~~**b.** The service location and telephone number or account number involved; (3-31-22)~~

~~**c.** The time over which the bill amount was accumulated; (3-31-22)~~

~~**d.** The amount owed; (3-31-22)~~

~~**e.** The reason(s) for adding the bill amount to the customer's billing statement; (3-31-22)~~

~~**f.** Statement that payment arrangements may be made on the amount owed; (3-31-22)~~

~~**g.** A statement that the customer has a right to contest the telephone company's proposed action by contacting the Commission; and (3-31-22)~~

~~**h.** The response deadline after which the bill amount will be added to the customer's billing statement. (3-31-22)~~

~~**05. Opportunity to Respond.** The telephone company will give the customer at least seven (7)~~

calendar days from the date of its proposed action to respond to the telephone company notice. (3-31-22)

206. -- 299. (RESERVED)

DENIAL, RESTRICTION, AND TERMINATION OF SERVICE
Rules 300 through 399

300. EXPLANATION FOR DENIAL OF A SERVICE TO A CUSTOMER (RULE 300).

If a telephone company intends to deny service to a customer under Rule 301, the telephone company will provide an explanation to the customer stating the reasons for the telephone company's refusal to provide service and the necessary action(s) to be taken to receive service. In the event of a dispute, the customer will be advised that an informal or formal complaint concerning denial of service may be filed with the Commission. (3-31-22)

301. GROUNDS FOR DENIAL OR TERMINATION OF LOCAL EXCHANGE SERVICE WITH PRIOR NOTICE (RULE 301).

A telephone company may deny or terminate local exchange service to a customer without the customer's permission, but only after adequate notice has been given in accordance with these rules, for one (1) or more of the following reasons: (3-31-22)

01. Customer Did Not Pay Undisputed Bills. With respect to undisputed past due bills for local exchange service, the customer: (3-31-22)

a. Failed to pay; (3-31-22)

b. Paid with a dishonored check; or (3-31-22)

c. Made an electronic payment drawn on an account with insufficient funds. (3-31-22)

d. The customer failed to make a security deposit, when one is required. ~~(3-31-22)~~()

e. The customer failed to abide by the terms of a payment arrangement. (3-31-22)

f. The telephone company determines as prescribed by relevant state or other applicable standards that the customer is willfully wasting or interfering with service through improper equipment or otherwise. (3-31-22)

g. The customer is a minor not competent to contract as described in Sections 29-101 and 32-101, Idaho Code. (3-31-22)

02. No Obligation to Connect Service. Nothing in this rule requires the telephone company to connect service for a customer who owes money on an existing account or from a previous account if the unpaid bill is for service provided within the past four (4) years. (3-31-22)

302. GROUNDS FOR DENIAL OR TERMINATION OF A SERVICE, WITHOUT PRIOR NOTICE (RULE 302).

A telephone company may deny or terminate a service or all services without prior notice to the customer and without the customer's permission for any of the following reasons: (3-31-22)

01. Dangerous Condition. A condition immediately dangerous or hazardous to life, physical safety, or property exists, or it is necessary to prevent a violation of federal, state or local safety or health codes. (3-31-22)

02. Ordered to Terminate Service. The telephone company is ordered to terminate service by any court, the Commission, or any other duly authorized public authority. (3-31-22)

03. Illegal Use of Services. The service(s) was (were) obtained, diverted or used without the authorization or knowledge of the telephone company. (3-31-22)

04. Customer Unable to Be Contacted. The telephone company has tried diligently to meet the notice

requirements of Rule 303, but has been unsuccessful in its attempt to contact the customer. (3-31-22)

05. Misrepresentation. The telephone company has determined that information provided by the customer is materially false or materially misrepresents the customer's true status. (3-31-22)

303. REQUIREMENTS FOR NOTICE BEFORE TERMINATION OF LOCAL EXCHANGE SERVICE (RULE 303).

01. Initial Notice. If the telephone company intends to terminate local exchange service under Rule 301, it will send to the customer written notice of termination mailed at least seven (7) calendar days before the proposed date of termination. Written notice may be provided by electronic mail (i.e. e-mail) if the customer is billed electronically and separately consents in writing to receiving electronic notification. This written notice will contain the information required by Rule 304. (3-31-22)

02. Final Notice. At least twenty-four (24) hours before actual termination, the telephone company will diligently attempt to contact the customer to apprise the customer of the proposed action and the steps the customer must take to avoid or delay termination. This oral notice will contain the same information required by Rule 304. (3-31-22)

03. Additional Notice. If the telephone company has not terminated service within twenty-one (21) days after the proposed termination date as specified in a notice, the telephone company will again provide notice under Rules 303.01 and 303.02 if it still intends to terminate service. (3-31-22)

04. Failure to Pay. No additional notice of termination is required if, upon receipt of a termination notice: (3-31-22)

a. The customer makes a payment arrangement and subsequently fails to keep that arrangement; (3-31-22)

b. The customer tenders payment with a dishonored check; or (3-31-22)

c. Makes an electronic payment drawn on an account with insufficient funds. (3-31-22)

304. CONTENTS OF NOTICE OF INTENT TO TERMINATE LOCAL EXCHANGE SERVICE (RULE 304).

01. Contents of Notice. The written, electronic or oral notice of intent to terminate local exchange service required by Rule 303 will state: (3-31-22)

a. The reason(s), citing these rules, why service will be terminated and the proposed date of termination; (3-31-22)

b. Actions the customer may take to avoid termination; (3-31-22)

c. That a certificate notifying the local exchange company of a serious illness or medical emergency in the household may delay termination under Rule 306; (3-31-22)

d. That an informal or formal complaint concerning termination may be filed with the telephone company or the Commission, and that service will not be terminated on grounds relating to the dispute between the customer and telephone company before resolution of the complaint (the Commission's mailing address, Internet address, and telephone number must be given to the customer); (3-31-22)

e. That the telephone company is willing to make payment arrangements (in a written notice this statement must be in bold print); and (3-31-22)

f. What amount must be paid in order to avoid termination of local exchange service and that partial payments will be applied toward past due charges for local exchange service first. (3-31-22)

305. SERIOUS ILLNESS OR MEDICAL EMERGENCY (RULE 305).

01. Medical Certificate -- Postponement of Termination of Local Exchange or Long-Distance Services. A telephone company offering local exchange or long-distance service between a residential customer and the customer's nearest community providing necessary medical facilities or services must postpone termination of local exchange or long-distance service to a residential customer for thirty (30) calendar days from the date of receipt of a written certificate signed by a licensed physician or public health official with medical training. The certificate must contain the following information: (3-31-22)

a. A statement that the customer, a member of the customer's family, or other permanent resident of the premises where service is provided, is seriously ill or has a medical emergency or will become seriously ill or may have a medical emergency because of termination of service; and that termination of local exchange service would adversely affect the health of that customer, member of the customer's family, or resident of the household. (3-31-22)

b. If the customer requests that termination of long-distance service be postponed, a statement that termination of long-distance service would impair the customer's ability to communicate with necessary medical facilities or services. (3-31-22)

c. The name of the person whose serious illness or medical emergency would be adversely affected by termination and the relationship to the customer. (3-31-22)

d. The name, title, and signature of the person certifying the serious illness or medical emergency. (3-31-22)

02. Restoration of Service. If local exchange or long-distance service has already been terminated when the medical certificate is received, the appropriate service will be restored as soon as possible, but no later than twenty-four (24) hours after receipt. The customer will receive local exchange and necessary long-distance services for thirty (30) calendar days from the telephone company's receipt of the certificate. (3-31-22)

03. Second Postponement. The telephone company may postpone termination of local exchange and necessary long-distance service for an additional thirty (30) days upon receipt of a second certificate stating that the serious illness or medical emergency still exists. (3-31-22)

04. Verification of Medical Certificate. The telephone company may verify the authenticity of the certificate and may refuse to delay termination of service if the certificate is a forgery or is otherwise fraudulent. (3-31-22)

05. Obligation to Pay. Nothing in this rule relieves the customer of the obligation to pay any undisputed bill. (3-31-22)

306. MEDICAL FACILITIES -- SHELTER CARE (RULE 306).

Where local exchange or long-distance services are provided to a customer known by the telephone company to be or identifying itself as a medical care facility, including a hospital, medical clinic with resident patients, nursing home, intermediate care facility or shelter care facility, notice of pending termination will be provided to the Commission as well as to the customer. Upon request from the Commission, a delay in termination of no less than seven (7) calendar days from the date of notice will be allowed so that action may be taken to protect the interests of the facility's residents. (3-31-22)

307. INSUFFICIENT GROUNDS FOR TERMINATION OF LOCAL EXCHANGE SERVICE (RULE 307).

01. Termination Prohibited. Telephone companies will not terminate service or provide notice of intent to terminate service if the unpaid bill cited as grounds for termination is: (3-31-22)

a. Less than thirty (\$30) dollars; (3-31-22)

b. For telephone service provided to any other customer or former customer (unless that customer has a legal obligation to pay the other bill) or for a class of service (business or residential) other than the one to which the customer currently subscribes; (3-31-22)

c. For MTS or other goods and services provided by the telephone company or for which the telephone company bills; (3-31-22)

d. For service provided four (4) or more years ago unless the customer made a payment on the bill within the past four (4) years, or the customer signed a written payment agreement and then failed to pay; (3-31-22)

e. The subject of an informal or formal complaint filed with the Commission; or (3-31-22)

f. Is at issue in a case pending before a court in the state of Idaho unless termination is authorized by court order. (3-31-22)

308. RESTRICTIONS ON TERMINATION OF LOCAL EXCHANGE SERVICE -- OPPORTUNITY TO AVOID TERMINATION OF LOCAL EXCHANGE SERVICE (RULE 308).

01. When Termination Not Allowed. Unless the customer affected has consented in writing, local exchange service will not be terminated on any Friday after twelve noon or on any Saturday, Sunday, legal holidays recognized by the state of Idaho, or after twelve noon on any day immediately before any legal holiday, or at any time when the telephone company's business offices are not open for business, except as authorized by Rules 302.01 and 302.02, or for non-residential customers, as authorized by any Subsection of Rule 302. Local exchange services may be terminated only between the hours of 8 a.m. and 4 p.m., except as authorized by Rules 302.01 and 302.02. (3-31-22)

02. Personnel to Authorize Reconnection. Each telephone company providing local exchange service will have personnel available after the time of termination who are authorized to reconnect service if the conditions cited as grounds for termination are corrected to the telephone company's satisfaction. Customers may be asked to pay reconnection fees before restoration of service. (3-31-22)

03. Service to Persons Not Customers. If local exchange service is provided to a residence and the account is in the name of one who does not reside there, the telephone company, prior to termination, will notify the person(s) receiving service and afford the person(s) a reasonable opportunity to negotiate directly with the telephone company to purchase service in the resident's(s') own name(s). (3-31-22)

04. No Termination While Complaint Pending. Except as authorized by order of the Commission or of the Judiciary, local exchange service will not be terminated for failure to pay amounts in dispute while a complaint over that telephone service filed pursuant to Rule 401 is pending before this Commission or while a case placing at issue payment for that telephone service is pending before a court in the state of Idaho. (3-31-22)

309. PAYMENT ARRANGEMENTS (RULE 309).

01. Arrangements Allowed. When a customer cannot pay a bill in full, the telephone company may continue to serve the customer if the customer and the telephone company agree on a reasonable portion of the outstanding bill to be paid immediately, and the manner in which the balance of the outstanding bill will be paid. (3-31-22)

02. Reasonableness. In deciding on the reasonableness of a particular agreement, the telephone company will take into account the customer's ability to pay, the size of the unpaid balance, the customer's payment history and length of service, and the amount of time and reasons why the debt is outstanding. (3-31-22)

03. Application of Payment. Payments are to be applied first to the undisputed past due balance owed by the customer for local exchange services. In discussing or negotiating payment arrangements, the telephone company shall advise the customer what amount of payment the customer must allocate to local exchange service or to long-distance service or other goods and services in order to retain those goods and services. (3-31-22)

04. Second Arrangement. If a customer fails to make the payment by the agreed due date, the telephone company may, but is not obligated to, enter into a second arrangement. (3-31-22)

05. When Arrangement Not Binding. No payment arrangement binds a customer if it requires the customer to forego any right provided for in these rules. (3-31-22)

310. DENIAL, RESTRICTION, MODIFICATION, OR TERMINATION OF LONG-DISTANCE SERVICE OR OTHER SERVICES (RULE 310).

01. Compliance. ~~Telephone companies regulated under Title 61, Idaho Code, providing long distance or other services must comply with Rules 300, 302, 308.03, 308.04, and 309 in connection with denial, restriction, modification, or termination of those services. Telephone companies providing long distance or other services must provide reasonable notice before terminating or restricting access to such services, except as provided by Rule 302.~~ Telephone companies providing long-distance services must provide reasonable notice before modifying a customer's existing service. ~~Nothing in this rule abrogates customers' rights under those telephone companies' tariffs or filings, written agreements with customer, or obligations otherwise imposed by statutory or common law.~~ (3-31-22)()

02. Failure to Pay. A customer's failure to pay for undisputed long-distance charges billed by the local exchange company may result in loss of 0+ or 0- and 1+ dialing access to long-distance services until such time as the customer pays the undisputed charges and any applicable reconnection charges. (3-31-22)

03. Loss of Services. Customer failure to pay undisputed charges for other services may result in loss of those services. (3-31-22)

311. CESSATION OF SERVICE IN A SERVICE AREA (RULE 311).

01. Single Local Service Provider. A telephone company that intends to terminate a service regulated under Title 61, Idaho Code, and an eligible telecommunications carrier that intends to terminate its universal service obligation in an area where it is the only eligible telecommunications carrier, must comply with the following: (3-31-22)

a. Petition the Commission for authority to terminate the service at least ninety (90) days before the company intends to terminate the service. If the Commission does not deny the petition or set it for hearing within ninety (90) days after receiving the petition, it shall be deemed approved; (3-31-22)

b. Mail a notice to each affected customer and to each telecommunications provider affected by the proposed cessation no later than ten (10) days after filing its petition with the Commission. (3-31-22)

c. Include with its petition a copy of the notice to customers and the number of customers affected by the proposed cessation; (3-31-22)

d. Demonstrate that the termination will not deprive the public of necessary telephone services; (3-31-22)

e. Obtain Commission approval before transferring customers to other telecommunications providers. (3-31-22)

02. Competitive Local Service Provider. A local exchange company that intends to terminate local exchange service that is not subject to regulation under Title 61, Idaho Code, and an eligible telecommunications carrier that intends to terminate its universal service obligation in an area where it is not the only eligible telecommunications carrier, must comply with the following: (3-31-22)

a. Provide notice to the Commission and each affected customer at least forty-five (45) days prior to the proposed termination of service; (3-31-22)

b. Inform the Commission of the number of customers and the other providers affected by the

proposed termination, and the company's plan to ensure that all customers served by the company will continue to be served; (3-31-22)

c. The telecommunications company may, after complying with this rule, transfer customers to another telecommunications provider without obtaining affirmative approval from affected customers if the following conditions are satisfied: (3-31-22)

i. The company terminating service has a written commitment from another provider to accept all of the exiting company's customers within the receiving company's service area; (3-31-22)

ii. All affected customers are notified at least forty-five (45) days in advance that they may apply to another telecommunications company for the service that is being terminated, and that if they do not obtain service from another provider, then the exiting company will automatically transfer them to the receiving company. (3-31-22)

iii. The receiving company may provide service to the terminating company's customers for up to forty-five (45) days without the affected customer applying for service from the receiving company. If the affected customers do not apply for service from or otherwise affirm an agreement to be served by the receiving company within forty-five (45) days, the receiving company may discontinue service. (3-31-22)

312. -- 399. (RESERVED)

COMPLAINT PROCEDURE
Rules 400 through 499

400. COMPLAINT TO TELEPHONE COMPANY (RULE 400).

01. Compliant. A customer for service may complain to the telephone company about any deposit or guarantee required as a condition of service, billing, termination of service, quality or availability of service, or any other matter regarding telephone company services, policies or practices for local exchange service, and other services. Complaints to the telephone company may be made orally or in writing. A complaint is considered filed when received by the telephone company. In making a complaint, the customer will state the customer's name, service address, telephone number and the general nature of the complaint. (3-31-22)

02. Investigation by Utility. The telephone company will promptly, thoroughly and completely investigate the complaint, notify the customer of the results of its investigation and make a good faith attempt to resolve the complaint. The oral or written notification will advise the customer that the customer may request the Commission to review the telephone company's proposed disposition of the complaint. (3-31-22)

03. Service Maintained. The telephone company will not terminate service based upon the subject matter of the complaint while investigating the complaint or making a good-faith attempt to resolve the complaint. (3-31-22)

401. COMPLAINT TO COMMISSION (RULE 401).

01. Informal Complaint. The Commission has authority to investigate and resolve complaints made by subscribers to telecommunication services that concern the quality and availability of local exchange service, or whether price and conditions of service are in conformance with filed tariffs or price lists, deposit requirements for such service or disconnection of such service. If a customer who has complained to a telephone company is dissatisfied with a telephone company's proposed disposition of the complaint, the customer may request the Commission to review informally the disputed issue and the telephone company's proposed disposition of the complaint. The Commission may consider complaints regarding any telephone services over which the Commission has authority. (3-31-22)

02. Termination of Service - Undisputed Bills. Telephone service will not be terminated nor shall termination be threatened by notice or otherwise while the complaint is pending before the Commission. The telephone company may continue to issue bills and request payment from the customer of any undisputed amounts.

(3-31-22)

03. Rights Protected. No customer will be denied the opportunity to file an informal or formal complaint with the Commission. (3-31-22)

402. RECORD OF COMPLAINTS (RULE 402).

01. Recordkeeping. Each telephone company must keep a record of written complaints pursuant to ~~Rules 400 and 401~~. These records must be retained for a minimum of one year by the telephone company where the complaints were received. These written records are to be readily available upon request by the complaining customer, the customer's agent possessing written authorization, or the Commission. (3-31-22)()

02. Reporting. When previously requested by the Commission, a telephone company must submit a report to the Commission that states and classifies the number of complaints made to the telephone company pursuant to Rules 400 and 401 and the general subject matter of the complaints. (3-31-22)

403. TELEPHONE COMPANY RESPONSE TO INFORMAL COMPLAINTS (RULE 403).

Within ten (10) business days of receiving notification that an informal complaint involving the telephone company has been filed with the Commission, telephone companies must respond either orally or in writing to the Commission. A telephone company will be granted an extension of time to prepare its response if it represents that it is making a good faith effort to resolve the matter in dispute. A full and complete response should be submitted to the Commission no later than thirty (30) days after receipt of notification from the Commission. (3-31-22)

404. -- 499. (RESERVED)

QUALITY OF SERVICE
Rules 500 through 599

500. QUALITY OF SERVICE (RULE 500).

01. Service Standards. Each telephone company providing local exchange service pursuant to Title 61 or Title 62, Idaho Code, as applicable, and each eligible telecommunications carrier (ETC) is required to employ prudent management and engineering practices to ensure that customers receive the best quality of service practicable. Each telephone company is required to adopt and pursue a maintenance program aimed at achieving efficient operation of its systems to render safe, adequate and uninterrupted service. These programs must include guidelines for keeping all plant and equipment in good repair, including the following: (3-31-22)

- a.** Broken, damaged or deteriorated equipment must be promptly repaired or replaced; and (3-31-22)
- b.** Transmission problems (including induction, cross-talk, or other poor transmission on any line) must be promptly corrected when located or identified. (3-31-22)

02. Service Outage. If a customer's local telephone service quality deteriorates to such an extent that the customer cannot make local calls or cannot receive local calls or cannot use the service for voice grade communication because of cross-talk, static or other transmission problem, the telephone company must respond to a customer's report of such a "service outage" in accordance with Rule 502. (3-31-22)

501. RESPONSE TO SERVICE OUTAGE (RULE 501).

01. Receipt and Recording of Reports. Each telephone company providing local exchange service will provide for the receipt of customer trouble reports at all hours and make a full and prompt investigation of and response to all reports. The telephone company will maintain an accurate record of trouble reports made by its customers. This record will include accurate identification of the affected customer or service, the time, date and nature of the report, the action taken to clear the trouble or satisfy the customer, and the date and time of trouble clearance or other disposition. This record will be available to the Commission or its authorized representatives upon request at any time within two (2) years of the date of the record. (3-31-22)

02. Repair Commitments. Commitments to customers for repair service will be set in accordance with Rule 502. Each telephone company will make every reasonable attempt to fulfill repair commitments to customers. Customers shall be timely notified of unavoidable changes. (3-31-22)

502. REPAIR SERVICE STANDARDS (RULE 502).

01. Restoration of Service. When a telephone company providing local exchange service is informed by a customer of a service outage as described in Rule 500.02, the telephone company will restore service within forty-eight (48) hours after the report of the outage, except: (3-31-22)

a. Restore service within sixteen (16) hours after the report of the outage if the customer notifies the telephone company that the service outage creates an emergency for the customer; or (3-31-22)

b. For outages reported on Friday, Saturday or Sunday, the company must restore service no later than the following Tuesday by 6 p.m. (3-31-22)

02. Extenuating Circumstances. Following disruption of telephone service caused by natural disaster or other causes not within the telephone company's control and affecting large groups of customers, or in conditions where the personal safety of an employee would be jeopardized, the telephone company is required to use reasonable judgment and diligence to restore service, giving due regard for the needs of various customers. When a customer causes the customer's own service outage or does not make a reasonable effort to arrange a repair visit within the service restoration deadline, or when the telephone company determines that the outage is attributable to the customer's own equipment or inside wire, the telephone company is not required to meet the restoration timelines of Rule 502.01. (3-31-22)

03. Compliance Standard. Each month at least eighty percent (80%) of out-of-service trouble reports shall be cleared in accordance with Rules 502.01 and 502.02. (3-31-22)

503. PAYTELEPHONE EMERGENCY ACCESS REQUIRED (RULE 503).

01. Access to Emergency Services. All telephones connected to an OSP are required: (3-31-22)

a. To provide direct access to a local exchange company operator for access to emergency services by dialing "0" (except for OSP customers like hotels, motels, hospitals, dormitories, etc., that direct "0" calls to a person on the OSP customer's premises), and (3-31-22)

b. Where available, to provide direct access to emergency service providers by dialing "911", unless exempted by the Commission pursuant to Rule 102.02 of this rule. Unless exempted, access to the OSP network (other than the local exchange company's) may be made through any other access number or keypad symbol. Exempted providers are required to maintain current lists of local emergency numbers. (3-31-22)

c. Provide or pass through the information required by Enhanced 911 service providers, including but not limited to, signaling system seven ("SS7") and automatic number identification ("ANI"). (3-31-22)

02. Emergency Dialing Instructions. All pay telephones owned or controlled by the OSP customer must be posted with emergency dialing instructions. (3-31-22)

~~**03. Termination of Service for Violation of This Rule.** Consistent with this Commission's rules on termination of service (Telephone Customer Relations Rules 300-314, IDAPA 31.41.01.300 through 31.41.01.314 and Rule 213 of these rules), the LEC must terminate service to customers of record known to be in violation of Rule 102.01 that have not been granted an exemption under Rule 102.02. The Commission or its Staff shall notify the LEC in writing of customers it knows to be in violation and whose service should be terminated. (3-31-22)~~

504. PAYTELEPHONE APPROVED INSTRUMENTS -- OPERATION OF INSTRUMENTS (RULE 504).

01. Registered or Exempt Instruments. All PSPs connecting pay telephones to the network must

connect pay telephone instruments that: (3-31-22)

a. Are registered under 47 CFR Part 68 of the Federal Communications Commission (FCC) Rules and Regulations (October 1, 2000) and comply with all Americans with Disabilities Act (ADA) requirements listed in the Code of Federal Regulations at 28 CFR Part 36 (July 1, 2000) and the Americans with Disabilities Act Accessibility Guidelines for Buildings and Facilities (“ADAAG”) (July 1, 2000). (3-31-22)

b. If not registered, are connected behind a protective coupler registered under Part 68 of the FCC Rules and Regulations; or (3-31-22)

c. Are exempted from registration by the FCC. See Title 47, Part 68.1 through 68.318 (October 1, 2000). (3-31-22)

02. Instruments for the Hearing Impaired. All owners of PSPs connecting pay telephones to the network must connect pay telephones that comply with the requirements of the Telecommunications for the Disabled Act of 1982 (January 3, 1983) and 47 CFR. Parts 68.112 and 68.316 (October 1, 2000) (which address access to the handicapped and hearing aid compatibility). (3-31-22)

505. PAYTELEPHONE EMERGENCY NUMBERS (RULE 505).

Pay telephones must allow coin-free operator and emergency 911 access in which 911 service is available. Where 911 service is not available, instructions for completing coin-free emergency calls must be posted on the pay telephone instrument as required in Rule 207. (3-31-22)

506. CONNECTION OF PAY TELEPHONES (RULE 506).

Pay telephones shall be connected only to public access lines (PAL). Every LEC must offer a PAL tariff or price list. There must be one (1) PAL for each pay telephone instrument. (3-31-22)

507. -- 599. (RESERVED)

MISCELLANEOUS PROVISIONS
Rules 600 through 699

600. INFORMATION TO CUSTOMERS (RULE 600).

01. Required Information. Each telephone company providing local exchange service will make the following information available to its customers: (3-31-22)

a. A summary of the general terms and conditions under which service is provided, referring to these rules as appropriate; (3-31-22)

b. A clear and concise explanation of: (3-31-22)

i. All the goods and services for which the customer is billed, including those goods and services provided as part of a package offered by the telephone company; (3-31-22)

ii. All recurring charges associated with individual goods and services or package of goods and services for which the customer is billed; (3-31-22)

iii. Any early termination fees that apply if the customer terminates service prior to the end of a service agreement or contract period; (3-31-22)

iv. The telephone company’s dispute resolution procedures and a statement that an informal or formal complaint may be filed with the Commission; and (3-31-22)

v. If the customer subscribes to non-published service, the circumstances under which the telephone company will release information about the customer or the customer’s service and to whom it will be released. (3-31-22)

02. When and How Information Provided. Information will be provided to customers in writing upon initiation of service and whenever a material change in the terms and conditions of service or charges for goods and services takes place. Information provided upon initiation of service may be separately mailed or included with the paper or electronic billing statement delivered to the customer. Subsequent notices may be made by separate mailing, included with a billing statement or, with the customer's consent, by electronic notice with reference to information contained on the telephone company's website. (3-31-22)

601. ACCESS TO EMERGENCY SERVICES (RULE 601).

In counties where consolidated emergency communications systems, as defined by Section 31-4802, Idaho Code, are established, the local exchange company will provide access to those services to all its customers. (3-31-22)

602. REQUEST FOR TELEPHONE COMPANY RECORDS (RULE 602).

01. General Rule. If any telephone company subject to these rules is directed by subpoena or court order to disclose customer records, as soon as practical, it will notify the customer what records were requested and of the company's response to the request. In no case will the reasonable period of time under this rule exceed two (2) business days after deciding to abide by that request. (3-31-22)

02. Exceptions. This rule does not apply if a judge of a court of competent jurisdiction has ordered a telephone company not to disclose that it has complied with a court order or subpoena to turn over a customer's telephone records. (3-31-22)

~~**603. AUTOMATIC RECORDING (RULE 603).**~~

~~Certain federal, state or local agencies have been permitted by rule or tariff approved by or filed with the Federal Communications Commission or this Commission to automatically record all telephone conversations on certain lines of the agency. This automatic recording is allowed for security, safety or public interest purposes. Release of telephone conversations automatically recorded by such a government agency for purposes unrelated to security, safety or the public interest is expressly prohibited under the authority of rules or tariffs authorizing automatic recording of conversations. This rule does not preclude the records' release pursuant to independent judicial, executive, legislative, or other order or authorization for release of such conversations, or upon consent of all parties whose conversations were recorded.~~ (3-31-22)

~~**603. (RESERVED)**~~

604. PUBLIC NOTICE (RULE 604).

Telephone companies will give "public notice" of all proposed changes in rates as required by Section 62-606, Idaho Code. Public notice required by 62-606 must be reasonably designed to call affected customers' attention to the proposed changes in rates. Legal advertisements alone will not be considered adequate public notice. Individual notice to all customers affected will always constitute public notice. Notices of rate increases must be provided to individual customers at least ten (10) days before change is effective. (3-31-22)()

~~**605. TELEPHONE SOLICITATIONS (RULE 605).**~~

~~Each telephone company providing local exchange service will summarize the provisions of Sections 48-1001 et seq., Idaho Code, in an annual insert in a billing statement mailed to customers or by conspicuous publication in the consumer pages of the local telephone directory. Local exchange companies may meet the requirements of this notice by publishing the following explanation or one (1) substantially similar:~~ (3-31-22)

~~**605. (RESERVED)**~~

606. INFORMATION, PRICE LISTS OR TARIFFS FOR NON-LOCAL EXCHANGE SERVICE (RULE 606).

~~**01. Information to be Filed.** All telephone corporations, except mutual nonprofit or cooperative corporations, that did not on January 1, 1988, hold a certificate of public convenience and necessity issued by the Commission and that do not provide basic local exchange service are required by Section 62-604(1)(b), Idaho Code, to file a notice with this Commission before offering services in Idaho. The notice must contain the following~~

~~information~~ The following must be additionally included on any notice required pursuant to 62-604(1)(b), Idaho Code: (3-31-22)()

~~a. The name of the telephone corporation and the business name of the telephone corporation if it does business under an assumed business name;~~ (3-31-22)

~~b. The United States and electronic (if available) mailing addresses of the principal place of business of the telephone corporation, and, if there is a principal place of business in Idaho, the addresses of the principal place of business in Idaho;~~ (3-31-22)

~~ea. An agent in Idaho for service of process by the Commission in the state of Idaho including the agent's United States and electronic (if available) mailing addresses;~~ (3-31-22)

~~d. A description of the telecommunication services offered by the telephone corporation and a map of the area(s) served by the telephone corporation or in which the telephone corporation offers or intends to offer service;~~ (3-31-22)

~~eb. Address(es) and toll-free telephone number(s) for personnel responsible for handling consumer inquiries, complaints, etc., by the public; and~~ (3-31-22)

~~fc. Name(s), United States mail and electronic (if available) addresses, and telephone number(s) of person(s) designated as a contact for the Commission Staff in resolving consumer complaints, responding to consumer inquiries, and answering matters concerning rates and price lists or tariffs. These notices must be updated at least annually, between December 1 and December 31 each year, and whenever there is a change in the telephone corporation's name, address, or agent for service of process.~~ (3-31-22)

02. Service. Notices, orders, rules, complaints and other documents issued by the Commission may be served by United States or electronic mail on the agent for service of process listed pursuant to this rule. This service constitutes due and timely notice to the telephone corporation, and no further service is necessary to bind the telephone corporation. Telephone corporations obligated by statute to file the notice required by this rule, but failing to do so, are bound by the Commission's motions, orders, rules, complaints and other documents upon their filing with the Commission Secretary. (3-31-22)

607. PRICE LISTS OR TARIFF FILINGS (RULE 607).

01. Price Lists or Tariffs. ~~All telephone corporations subject to the Telecommunications Act of 1988 are required by Section 62-606, Idaho Code, or by this Commission's implementation of Section 62-616, Idaho Code, to file for informational purposes price lists or tariffs that reflect the availability, price, terms and conditions of all telecommunication services not offered under Title 61 of the Idaho Code. The notice requirements of Section 62-606, Idaho Code, for price lists or tariffs must include:~~ (3-31-22)()

a. Contain a title page identifying the telephone corporation; (3-31-22)

b. Show on each page the name of the company, the date of issuance and an effective date for their rates; (3-31-22)

c. Contain a table of contents; (3-31-22)

d. Number pages and paragraphs describing the services; (3-31-22)

e. Show when pages or services have been cancelled or revised; and (3-31-22)

f. Provide a mechanism (e.g., page revision numbers) for tracing additions, deletions or amendments to the price list or tariff. The price lists or tariffs must include schedules of rates for each type of service generally made available to subscribers, showing the effective date of all rates and charges and listing any rules and regulations associated with provision of the services. Surcharges, discounts, hours of availability, minimum service periods, and other conditions of service must be detailed. (3-31-22)

~~02. Changes to Price Lists or Tariffs. When required by Section 62-606, Idaho Code, changes to price lists or tariffs are effective not less than ten (10) days after filing with the Commission and giving public notice to affected customers except for charges for non-recurring services quoted directly to the customer when an order is placed or price reductions, both of which may take effect immediately with filing. Changes to price lists or tariffs must be accompanied by a letter of transmittal stating how affected customers received notice of the changes to price lists or tariffs. See Rule 604. (3-31-22)()~~

03. Tracking Price Lists or Tariffs. Each revision to a price list or tariff must be accompanied by a cover letter summarizing the changes to the price list or tariff, specifically referring to existing tariff pages affected by the new price list or tariff and stating whether new pages replace, are in addition to, or delete existing pages. The Commission Secretary may adopt a system to number each company's changes to its price lists or tariffs. (3-31-22)

608. FORM AND NUMBER OF COPIES OF PRICE LIST OR TARIFF (RULE 608).

Price lists or tariffs filed pursuant to Section 62-606, Idaho Code, or by this Commission's implementation of Section 62-616, Idaho Code, must have a blank space approximately three by one and one-half inches (3" x 1-1/2") square provided for the Commission's filing stamp in the upper right or lower right corner of each schedule filed. An original and three (3) copies of the price list or tariff must be filed with the Commission. The Commission stamps its indication that the price list or tariff has been filed in the space provided on each copy of the price list or tariff, placing the original in its files and returning one copy to the telephone corporation. (3-31-22)

~~609. -- 699701. (RESERVED)~~

SLAMMING PROVISIONS

~~Rules 700 through 79902~~

~~**700. THE UNAUTHORIZED CHANGE OF A CUSTOMER'S TELEPHONE COMPANY (RULE 700).**~~

~~Local exchange companies and interexchange carriers are prohibited from submitting or executing an unauthorized change in a customer's selection of a provider of local or long distance telephone service. This practice is commonly referred to as "slamming." The Commission will administer the Federal Communications Commission's regulations regarding slamming. (3-31-22)~~

~~**701. ADOPTION OF FEDERAL SLAMMING REGULATIONS (RULE 701).**~~

~~The Commission adopts the slamming regulations promulgated by the Federal Communications Commission and found at Sections 64.1100 through 64.1170 and 64.1190, Title 47, Code of Federal Regulations (October 1, 2004). (3-31-22)~~

~~**702. STATE PROCEDURES (RULE 702).**~~

~~The federal slamming procedures incorporated by reference in Rule 701 are modified as follows: (3-31-22)~~

~~**01. Form.** Complaints regarding an unauthorized carrier change may be filed with the Commission in person, by mail, by e-mail, or by telephone. E-mail complaint forms to secretary@puc.idaho.gov. A copy of the telephone bill(s) in dispute and other relevant evidence shall be provided to the Commission by the complaining party. The slamming complaint shall include the following information: (3-31-22)~~

- ~~a. Name, address and telephone number of complainant; (3-31-22)~~
- ~~b. Name/identity of the alleged slamming carrier; (3-31-22)~~
- ~~c. Name of the previous authorized carrier; (3-31-22)~~
- ~~d. Name of the billing entity; (3-31-22)~~
- ~~e. Date the alleged slamming occurred; (3-31-22)~~
- ~~f. Whether the customer has been restored to the preferred carrier; (3-31-22)~~

- ~~g.~~ ~~Whether the customer has paid any or all of the disputed charges;~~ ~~(3-31-22)~~
- ~~h.~~ ~~Efforts in attempting to resolve the alleged slamming; and~~ ~~(3-31-22)~~
- ~~i.~~ ~~Whether the customer was charged for changing carrier(s).~~ ~~(3-31-22)~~

021. **Procedure.** The Commission’s Consumer Assistance Staff shall be responsible for resolving slamming complaints under the Commission’s informal complaint procedures in IDAPA 31.01.01, “Rules of Procedure of the Idaho Public Utilities Commission,” Rules 21 through 24. Not later than twenty-one (21) calendar days after notification of a slamming complaint, the alleged unauthorized carrier shall provide to the Consumer Assistance Staff a copy of any valid proof of verification of the carrier change and any other evidence relevant to the complaint. ~~Use of the Commission’s informal complaint procedures are mandatory.~~ ~~(3-31-22)~~()

703. -- 999. (RESERVED)

IDAPA 37 – IDAHO DEPARTMENT OF WATER RESOURCES

37.03.01 – ADJUDICATION RULES

DOCKET NO. 37-0301-2401 (ZBR CHAPTER REWRITE)

NOTICE OF RULEMAKING – PROPOSED RULE

AUTHORITY: In compliance with Section 67-5221(1), Idaho Code, notice is hereby given that this agency has initiated proposed rulemaking procedures. The action is authorized pursuant to Section(s) 42-1805(8), Idaho Code.

PUBLIC HEARING SCHEDULE: Public hearing(s) concerning this rulemaking will be scheduled if requested in writing by twenty-five (25) persons, a political subdivision, or an agency, no later than October 16, 2024.

The hearing site(s) will be accessible to persons with disabilities. Requests for accommodation must be made no later than five (5) days prior to the hearing, to the agency address below.

DESCRIPTIVE SUMMARY: The following is a nontechnical explanation of the substance and purpose of the proposed rulemaking:

The Idaho Department of Water Resources (IDWR) initiated this rulemaking in compliance with [Executive Order No. 2020-01, Zero-Based Regulation \(ZBR\)](#) (EO 2020-01), issued by Governor Little on January 16, 2020. Pursuant to EO 2020-01, each rule chapter effective on June 30, 2020, must be reviewed by the promulgating agency over a five-year period. This review is being conducted according to a schedule established by the Division of Financial Management, Office of the Governor (DFM), posted at <https://adminrules.idaho.gov>. This rule chapter was scheduled for review in 2024.

With this Notice, IDWR proposes a new chapter of adjudication rules. The new chapter is approximately 17% shorter than the existing adjudication rule chapter due to both internal agency analysis and external stakeholder negotiation, commentary, and editing. Changes to the rule (a) clarify the minimum requirements for completing a notice of claim to a water right acquired under state law, establishes clear criteria for calculation of claim filing fees, sets clear criteria for refunding fees, and establishes criteria for rejecting incomplete claims. IDWR believes the regulatory measures in the Rule are necessary for the orderly, consistent, and efficient processing of adjudication claims filed in connection with any of the active general stream adjudications within the state.

The development of the proposed rule text through two publicly-released preliminary rule draft iterations may be viewed at: <https://idwr.idaho.gov/legal-actions/rules/idwr-rulemaking-2024-2025/adjudication-rules/>. On the same website, IDWR also developed and published rulemaking support documents, which provide IDWR's recommendations on rulemaking, rulemaking analysis, and responses to substantive comments received through the negotiated rulemaking process.

After consideration of public comments received in response to this Proposed Rule, IDWR will present the final rule text during the 2025 Legislative Session.

FEE SUMMARY: The following is a specific description of the fee or charge imposed or increased:

IDAPA 37.03.01 sets the minimum requirements for completing a notice of claim to a water right acquired under state law which includes establishing clear criteria for calculation of claim filing fees including flat fees, variable fees, and late fees, as set forth in Idaho Code § 42-1414.

FISCAL IMPACT: The following is a specific description, if applicable, of any negative fiscal impact on the state General Fund greater than ten thousand dollars (\$10,000) during the fiscal year as a result of this rulemaking: N/A.

NEGOTIATED RULEMAKING: Pursuant to Section 67-5220(1), Idaho Code, negotiated rulemaking was conducted. The Notice of Intent to Promulgate Rules - Negotiated Rulemaking was published in the April 3, 2024 Idaho Administrative Bulletin, [Vol. 24-4, pages 50-51](#).

INCORPORATION BY REFERENCE: Pursuant to Section 67-5229(2)(a), Idaho Code, the following is a brief synopsis of why the materials cited are being incorporated by reference into this rule: N/A.

ASSISTANCE ON TECHNICAL QUESTIONS, SUBMISSION OF WRITTEN COMMENTS: For assistance on technical questions concerning the proposed rule, contact Erik Boe at Erik.Boe@idwr.idaho.gov, (208) 287-4800.

Anyone may submit written comments regarding this proposed rulemaking by mail to the address below or by email to rulesinfo@idwr.idaho.gov. All written comments must be directed to the undersigned and must be delivered on or before October 23, 2024.

DATED this 30th day of August, 2024.

Erik Boe, Water Compliance Bureau Chief, Rules Regulation Officer
Idaho Department of Water Resources
322 E. Front Street
PO Box 83720 Boise, ID 83720-0098
Phone: (208) 287-4800

THE FOLLOWING IS THE PROPOSED TEXT OF DOCKET NO. 37-0301-2401
(ZBR Chapter Rewrite)

37.03.01 – ADJUDICATION RULES

000. LEGAL AUTHORITY.

These rules are adopted under the legal authorities of Section ~~42-1414~~, and 42-1805(8), Idaho Code.

(3-18-22)()

001. ~~TITLE AND SCOPE.~~

~~01. Title.~~ These rules are titled IDAPA 37.03.01, “Adjudication Rules.”

(3-18-22)

~~02. Scope.~~ These rules implement statutes governing the filing of notices of claims to water rights acquired under state law and the collection of fees for filing notices of claims to water rights acquired under state law in general adjudications, as provided in pursuant to Sections 42-1409, 42-1409A, and 42-1414 ~~and 42-1415~~, Idaho Code.

(3-18-22)()

002. -- 009. (RESERVED)

010. DEFINITIONS.

01. Amendment Fee. The additional fee ~~payable~~ required at the time of filing an amendment to a claim, ~~as provided in Section 42-1414(2), Idaho Code.~~

(3-18-22)()

02. Aquaculture. The use of water for propagation of fish, shell-fish, and any other animal or plant product naturally occurring in an underwater environment.

(3-18-22)()

~~03. Aquaculture Fee.~~ The variable fee payable for aquaculture use, ~~as provided in Section 42-1414(1)(b)(iii), Idaho Code, which shall be calculated for each cfs and fraction thereof to the nearest dollar.~~

(3-18-22)

043. Claim. A notice of claim to a water right acquired under state law, as provided in filed pursuant to Section 42-1409(4), Idaho Code.

(3-18-22)()

- ~~054.~~ **Department.** The Idaho Department of Water Resources. (3-18-22)
- ~~065.~~ **Director.** The Director of the Idaho Department of Water Resources. Per Section 42-1701(3), Idaho Code, the Director may delegate authority to perform duties imposed upon the Director by law, including duties described herein, to a Department employee. (3-18-22)()
- ~~076.~~ **Domestic Use.** Domestic use as defined in Section 42-1401A(4), Idaho Code. (3-18-22)
- ~~087.~~ **Flat Fee.** The per claim fee for filing a claims, ~~as provided in pursuant to~~ Section 42-1414(1)(a), Idaho Code. (3-18-22)()
- ~~098.~~ **Late Fee.** The additional fee ~~payable~~ required for the filing of a late claims, ~~as provided in pursuant to~~ Section 42-1414(3), Idaho Code. (3-18-22)()
- ~~10.~~ **~~Per Acre Fee.~~** ~~The variable fee for irrigation use, as provided in Section 42-1414(1)(b)(i), Idaho Code, which shall be calculated for each acre and fraction thereof rounded to the next whole acre.~~ (3-18-22)
- ~~11.~~ **~~Per Cfs Fee.~~** ~~The variable fee payable for other uses, as provided in Section 42-1414(1)(b)(iii), (iv) and (v), Idaho Code, which shall be calculated for each cfs and fraction thereof to the nearest dollar.~~ (3-18-22)
- ~~12.~~ **~~Per Kilowatt Fee.~~** ~~The variable fee payable for power generation use, as provided in Section 42-1414(1)(b)(ii), Idaho Code, which shall be calculated for each kilowatt and fraction thereof.~~ (3-18-22)
- ~~13.~~ **~~State Law Claim Form.~~** ~~The department's form entitled "Notice of Claim to a Water Right Acquired Under State Law as provided in Section 42-1409(4), Idaho Code.~~ (3-18-22)
- ~~09.~~ **Public Entity.** A state or local government, or any agency, office, or department run by a state or local government. ()
- ~~10.~~ **Public Purpose.** Use of water by a public entity for in-stream flows, lake level maintenance, wildlife, aesthetic, or recreation use. ()
- ~~141.~~ **Stock Watering Use.** Stock watering use as defined in Section 42-1401A(11), Idaho Code. (3-18-22)
- ~~152.~~ **Total Fee.** The fee ~~payable~~ required for filing a claim, ~~which consists~~ consisting of the flat fee plus any applicable variable fee and late fee. (3-18-22)()
- ~~163.~~ **Variable Fee.** The fee ~~payable~~ required for filing claims in addition to the flat fee, ~~as provided in pursuant to~~ Section 42-1414(1)(b), Idaho Code. (3-18-22)()
- ~~174.~~ **Water Delivery System.** All structures and equipment used for diversion, storage, transportation, and use of water from the water source to and including each place of use. (3-18-22)
- ~~185.~~ **Water Delivery Organization.** An irrigation district, ~~a~~ water utility, ~~a~~ municipality, or any similar claimant of a water right who diverts water pursuant to the water right claimed and delivers the water to others who make beneficial use of the water ~~diverted by the water delivery organization pursuant to the water right claimed by the water delivery organization.~~ (3-18-22)()
011. **ABBREVIATIONS.**
01. **AF.** ~~An acre~~ Acre foot (feet). (3-18-22)()
02. **CFS.** Cubic foot (feet) per second. (3-18-22)
- ~~03.~~ **~~NA.~~** ~~Not applicable.~~ (3-18-22)

~~04. PIN. Parcel identification number. (3-18-22)~~

012. -- 024. (RESERVED)

025. GENERAL.

01. **Requirement to Pay.** All persons filing claims ~~to water rights acquired under state law~~ or amendments to claims ~~to water rights acquired under state law shall be~~ are required to pay filing fees as set forth by statute and these rules. (3-18-22)()

02. **Method of Payment.** Fees ~~shall~~ may be paid in ~~legal tender of the United States~~ cash; or by money order, certified check, cashier's check, personal check, debit or credit card, or by electronic payment on-line ~~payable to the department in legal tender of the United States. Two party checks will not be accepted.~~ (3-18-22)()

03. **Personal Check.** If a personal check ~~in payment of a flat fee, a variable fee, or a late fee,~~ is returned unpaid to the ~~d~~Department or the debit or credit card payment is rejected by the financial institution, the claims ~~covered by the returned check or the rejected debit or credit card~~ will be rejected and returned to the claimant. If a personal check in payment of an amendment fee is returned unpaid to the ~~d~~Department or the debit or credit card payment is rejected by the financial institution, the amended claim will be rejected and returned to the claimant, but the original claim will still be in effect. (3-18-22)()

~~04. Time of Payment. Flat fees and variable fees shall be payable to the department at the time of filing a claim. Amendment fees shall be payable to the department at the time of filing the amended claim. Late fees shall be payable at the time of filing the late claim. (3-18-22)~~

054. **Government Voucher.** Fees payable by government agencies (other than agencies of foreign governments) may be paid ~~when due~~ by government voucher. If full payment of the voucher is not received within forty-five (45) days of the date the voucher is received, the unpaid voucher will be treated as a returned check ~~as provided in pursuant to~~ Subsection 025.03. (3-18-22)()

065. **Rejection of Claim.** Claims submitted without the correct filing fee ~~shall~~ will be rejected and returned to the claimant along with any fees paid. (3-18-22)()

076. **Fire-Fighting.** A claim is not required ~~to be filed~~ for water used solely to extinguish or prevent spreading of an existing fire on private or public lands, structures, or equipment, ~~or to prevent an existing fire from spreading to private or public lands, structures, or equipment endangered by an existing fire~~ pursuant to Section 42-201(3), Idaho Code. A claim is required for the use of water for ~~domestic purposes in regularly maintained~~ firefighting stations and for the storage of water for fighting future fires. (3-18-22)()

026. -- 029. (RESERVED)

030. FLAT FEES.

01. **Small Domestic and Stock Water.** A flat fee of twenty-five dollars (\$25) ~~shall be payable is~~ required for each claim for domestic use and/or stock watering use meeting the definition of domestic use and/or stock watering use in Rule Section 010. Filing fees for claims for stock water use only are assessed for the first four (4) claims filed by a claimant. (3-18-22)()

02. **Other Claims.** A flat fee of fifty dollars (\$50) ~~shall be payable is~~ required for each claim that does not meet the criteria of Subsection 030.01. (3-18-22)()

031. -- 034. (RESERVED)

035. VARIABLE FEES.

01. **General.** A variable fee in addition to the flat fee is required Ffor each claim not meeting the

criteria of Subsection 030.01, ~~there may be a variable fee in addition to the flat fee~~ unless otherwise stated in these rules. (3-18-22)()

02. Per Acre Fee. The variable fee for irrigation use, pursuant to Section 42-1414(1)(b)(i), Idaho Code, is calculated for each acre and fraction thereof rounded to the next whole acre. (3-18-22)()

a. A fee of one dollar (\$1.00) per acre ~~shall be~~ is required for ~~claims for an~~ irrigation use claim. (3-18-22)()

b. The per acre fee ~~shall is~~ only be charged once against a particular acre, regardless of the number of claims filed for the irrigation of that acre or the number of claimants filing claims for the irrigation of that acre. (3-18-22)()

c. The per acre fee ~~shall be~~ is payable by the first person to file a claim for the irrigation of a particular acre. (3-18-22)()

d. The per acre fee for an irrigation project where the canals constructed cover an area of twenty-five thousand (25,000) acres or more, or irrigation districts organized and existing as such under the laws of the state of Idaho, or for beneficial use by more than five (5) water users in an area of less than twenty-five thousand (25,000) acres ~~shall will~~ be determined based upon the acreage claimed to be irrigated by the project or irrigation district within the boundaries of the project or irrigation district. (3-18-22)()

03. Per Kilowatt Fee. The variable fee for power generation pursuant to Section 42-1414(1)(b)(ii), Idaho Code, calculated for each kilowatt and fraction thereof. (3-18-22)()

a. A per kilowatt of capacity (manufacturer's nameplate rating) fee of three dollars and fifty cents (\$3.50) per kilowatt, or two hundred fifty thousand dollars (\$250,000.00), whichever is less, ~~shall be~~ is required for a power generation ~~claims for power use.~~ (3-18-22)()

b. The per kilowatt fee ~~shall be~~ is determined based upon the total generating capacity of all generators in which the water right claimed is used. (3-18-22)()

c. The total per kilowatt fee for all claims filed for a single hydropower facility ~~shall will~~ not exceed the per kilowatt fee for the total generating capacity of all generators in the hydropower facility. (3-18-22)()

04. Per CFS Fee. The variable fee for a use other than those identified in Subsections 035.01, 035.02, and 035.03, pursuant to Section 42-1414(1)(b)(iii), (iv), and (v), Idaho Code, calculated for each cfs and fraction thereof to the nearest dollar. (3-18-22)()

a. A fee of ten dollars (\$10) per cfs ~~for aquaculture shall be~~ is required for an aquaculture use claim. A fee of one hundred dollars (\$100) per cfs is required for all other uses ~~shall be required~~ except for irrigation, power, and domestic and stock watering uses meeting the definition of domestic and stock watering use in Section 010. (3-18-22)()

b. For a claim ~~to water~~ for more than one (1) public purpose, the per cfs fee ~~shall only will~~ be charged only once per cfs claimed. ~~Public purposes shall include public in-stream flows, lake level maintenance, wildlife, aesthetic beauty, and recreation.~~ (3-18-22)()

c. If there is a seasonal variation in the number of cfs claimed, the per cfs fee ~~shall be~~ is based upon the maximum number of cfs claimed for any period during a single calendar year. (3-18-22)()

~~d. The per cfs fee shall apply to claims for water quality improvement, recreation, aesthetic purposes, and any other purpose not expressly listed at Section 42-1414(1), Idaho Code, except as otherwise provided by these rules.~~ (3-18-22)

05. Claims Including Storage. (3-18-22)

~~a.~~ The ~~variable fee for a claim that includes storage shall be based upon the ultimate use of the water stored.~~ ultimate use of the water stored determines the variable fee for a claim that includes storage. If ~~the a~~ claim states a purposes other than diversion to storage, storage, and diversion from storage, the total variable fee will be determined ~~as provided in pursuant~~ Subsection 035.06. (3-18-22)()

~~b.~~ No variable fee shall be payable for water claimed for ground water recharge purposes. (3-18-22)

~~eb.~~ For purposes of determining the per cfs fee for the amounts of water claimed in af, one (1) cfs equals one and ninety-eight one-hundredths (1.98) af per day of diversion to storage. (3-18-22)()

~~d.~~ No variable fee shall be payable for minimum by-pass flows. (3-18-22)

06. Multiple Purpose Claims. If a ~~claimant~~ claims includes more than one (1) purpose of use ~~on a single claim~~, the variable fee will be the total of the variable fees payable required for each purpose of use. (3-18-22)()

07. Exceptions. No variable fee ~~shall be payable~~ is required for a claims or portions of a claims for ground water recharge purposes, fire-fighting purposes, ~~if a claim is required under Subsection 025.07 or for domestic use and/or stock watering use meeting the definitions of domestic use and stock watering use in Section 010.~~ (3-18-22)()

036. -- 044. (RESERVED)

045. AMENDMENT FEES.

When a claimant files an amendment to a claim, ~~the total fee shall be recalculated as if the amended claim were the original claim.~~ I if the total fee as recalculated is greater than the total fee paid at the time the claim was originally filed, the amendment fee shall be is the difference between the two (2) amounts. No refund ~~shall be made~~ is issued if the total fee as recalculated is less than the total fee paid at the time the claim was originally filed. (3-18-22)()

046. -- 049. (RESERVED)

050. LATE FEES.

01. Late Fee Payable. A late fee ~~shall be payable when~~ is required for a claim ~~is~~ filed after the date set forth in the first commencement notice mailed to the claimant or the claimant's predecessor in interest pursuant to Sections 42-1414(3), Idaho Code. (3-18-22)()

02. Waiver. The late fee may be waived by the ~~d~~Director for good cause shown. (3-18-22)()

051. -- 054. (RESERVED)

055. REFUNDS.

Fees ~~shall~~ will not be refunded or returned except where the fee was miscalculated at the time the claim was filed or as expressly provided in these rules. (3-18-22)()

056. -- 059. (RESERVED)

060. SUFFICIENCY OF CLAIMS.

01. Single Claim. Except for claims based on both state law and federal law, a single claim may describe only one (1) water right. ~~A claim that describes more than one (1) water right will be rejected and returned along with any fees paid, and must be refiled as multiple claims.~~ (3-18-22)()

02. State Law Claim Form—Minimum Requirements. Claims filed on the state law A claim form ~~shall contain the following information~~ must be filed: (3-18-22)()

a. On the Department's form entitled "Notice of Claim to a Water Right Acquired Under State Law."

or equivalent form approved by the Department, with any applicable attachments. ()

b. In accordance with IDAPA 37.01.01, “Rules of Procedure of the Idaho Department of Water Resources,” Section 053, either on paper, digitally in PDF format, or through the Department’s online filing process. ()

c. With required filing fees pursuant to Sections 030 and 035. ()

d. In accordance with the minimum requirements pursuant to Subsection 060.03. ()

03. Minimum Requirements. Claims filed on the claim form must contain the following information: ()

a. Name, Address and Phone Number of Claimant. The name, and mailing address, and phone number of the claimant and all co-claimants claiming jointly filing the notice of claim to a water right jointly with the claimant shall be listed at item one (1) of the form. (3-18-22)()

b. Date of Priority. The date of priority shall be listed at item two (2) of the form, and shall include including month, day and year. Only one (1) priority may be stated unless the claim is based upon both state and federal law as provided in Subsection 060.01. If more than one (1) priority date is stated, the claim will be rejected and returned along with any fees paid, and must be refiled as multiple claims. (3-18-22)()

i. Within thirty (30) days, unless an extension by the director or his designee is approved, the claimant shall provide evidence of the priority date to support the water right claimed. If the claimant fails to provide evidence of priority, the form may be rejected and returned with no refund of the fees paid. List only one (1) date of priority, the date the water right was established, unless the claim is based upon both state and federal law pursuant to Subsection 060.01. (3-18-22)()

c. Source of Water Supply. The source of water supply shall be stated at item three (3) of the form. (3-18-22)()

i. For a surface water sources, the source of water shall be identified by include the official geographic name listed on the U.S. United States Geological Survey (USGS) Quadrangle map. If no official name has been given, the name in local common usage should be listed. If there is no official or common name, the source should be described as “unnamed stream” or “spring.” The first named downstream water source to which the source is tributary shall also be listed. For ground water sources, the source shall be listed as “ground water.” the source of water is not named on the USGS Quadrangle map, describe it as an unnamed water body, such as “unnamed stream.” For surface water sources, also identify the first named stream or river to which the source is tributary. If the water source sinks into the ground before reaching a stream named on the USGS Quadrangle map, describe the “tributary to” stream as “sinks.” If the water source flows into a stream named on the USGS Quadrangle map for part of the year and sinks into the ground for the other part of the year, identify the “tributary to” stream as the named stream on the USGS Quadrangle map. (3-18-22)()

ii. Only Identify only one (1) water source shall be listed unless the claim is for a single interconnected water delivery system that has diverts water from more than one (1) source, or the claim is for a single licensed or decreed right that covers more than one (1) water delivery system. If more than one (1) source is listed and the claim is not for a single water delivery system that has more than one (1) source, and the claim is not for a single licensed or decreed water right that covers more than one (1) water delivery system, the claim will be rejected and returned along with any fees paid, and must be refiled as multiple claims. (3-18-22)()

iii. For a water source under the ground surface, identify the source as “ground water.” ()

d. Location of Point of Diversion. For claims other than in-stream flows, the location of the point(s) of diversion shall be listed at item four (4) part (a) of the form. For claims to in-stream flows, the beginning and ending points of the claimed in-stream flow shall be listed at item four (4) part (b) of the form. Point of diversion. Describe the location of the point of diversion to the nearest forty (40) acre tract (quarter-quarter section) or government lot number, and include township number (including north or south designations), range number (including east or west designations), section number, and county. (3-18-22)()

- i. ~~The location of the point of diversion shall be described to nearest forty (40) acre tract (quarter-quarter section) or government lot number, and shall include township number (including north or south designations), range number (including east or west designations), section number, and county.~~ Describe the beginning and ending points of instream flow use, if claimed. (3-18-22)()
- ii. ~~The claimant shall also list the Parcel Number or~~ Parcel Identification Number (PIN) as assigned by the county assessor's office for the parcel where the water is diverted unless no ~~Parcel Number or~~ PIN is recorded for the property at the point of diversion. (3-18-22)()
- iii. List the subdivision name, block number, and lot number. ~~If the point of diversion is located in a platted subdivision, a where the plat of which has been is recorded in the county recorder's office for the county in which the subdivision is located, the claimant shall also list the subdivision name, block number and lot number in item thirteen (13) of the form (remarks section).~~ (3-18-22)()
- iv. ~~A claim to a water right that includes storage shall state~~ must include the point at which water is impounded (~~applicable only to for an on-stream reservoirs~~) or the point at which water is diverted to storage (~~applicable only to for an off-stream reservoirs~~), ~~the point at which water is released from storage into a natural stream channel (applicable only. For a claim where a natural stream channel is used to convey stored water), and include the point at which water is diverted into a natural channel, and the point where water is~~ rediverted (applicable only where a natural channel is used to convey stored water) from the natural channel. (3-18-22)()
- v. Only list only one (1) point of diversion ~~shall be listed~~ unless the claim is for a single water delivery system that has more than one (1) point of diversion, or the claim is for a single licensed or decreed water right that covers more than one (1) water delivery system. ~~If more than one (1) point of diversion is listed and the claim is not for a single water delivery system that has more than one (1) point of diversion, and the claim is not for a single licensed or decreed water right that covers more than one (1) water delivery system, the claim will be rejected and returned along with any fees paid, and must be refiled as multiple claims.~~ (3-18-22)()
- e. Description of Diversion Works. ~~The diversion works shall be described at item five (5) of the form.~~
- i. ~~The description shall include~~ Describe all major components of the water delivery system, such as dams, reservoirs, ditches, pipelines, pumps, wells, headgates, etc. ~~The description shall also include~~ Include those dimensions of major components which affect the diversion capacity of the water delivery system. ~~The description shall also state whether the ditches are lined and/or covered, Include the depth of wells, the horsepower capacity of rating of installed pumps, and whether headgates are automatic or equipped with locks and/or measuring devices.~~ (3-18-22)()
- ii. ~~The description shall~~ For a claim asserting an accomplished transfer pursuant to Section 42-1425, Idaho Code, include the dates and a description of any changes in use (including change in point of diversion, place of use, purpose of use, and period of use) ~~or enlargements in use (including an increase in the amount of water diverted, the number of acres irrigated, or additional uses of water), and as to those dimensions required to be described above, the dimensions as originally constructed and as enlarged.~~ Describe the diversion works before and after the accomplished transfer. (3-18-22)()
- iii. For a claim describing an enlargement in use pursuant to Section 42-1426, Idaho Code, identify the water right enlarged (base right) and the date the enlargement occurred. Identify the enlarged element of the base right including number of acres irrigated, extended season of use, or additional uses of water. Describe the diversion works as originally constructed and as enlarged. ()
- iv. For claim describing an expansion in use pursuant to Section 42-1416B, Idaho Code, identify the water right expanded (base right) and the date the expansion occurred. Identify the expanded element of the base right including number of acres irrigated or additional uses of water. Describe the diversion works as originally constructed and as expanded. ()
- iii.v. ~~Water delivery organizations shall~~ must describe the water delivery system up to and including the

point where responsibility for water distribution is assumed by entities other than the water delivery organization.

(3-18-22)()

~~f. Purpose of Use and Period of Use. Each purpose for which water is claimed, the period of use for each purpose for which water is claimed, and the amount of water claimed for each purpose for which water is claimed shall be listed at item six (6) of the form. Period of use shall include the month and day of the first and last day of use. For example, the period of use for domestic use is often January 1st through December 31st.~~

(3-18-22)()

~~i. The purpose may be described. Describe each purpose of use in general terms such as irrigation, industrial, municipal, mining, power-generation, fish propagation, domestic, stock watering, etc.~~

(3-18-22)()

~~ii. A claim to a water right that includes storage shall use must be broken down separated into component purposes with the ultimate use(s) of the stored water indicated. The component purposes of a storage right are: diversion to storage (not applicable to an on-stream reservoirs), storage, and diversion from storage (not applicable where the ultimate use is an in-reservoir public purpose). Detention of water in a holding pond, where the pond is not the end use of the water, that can be filled in less than twenty-four (24) hours at the claimed diversion rate is not required to be claimed as storage. The amount of water claimed shall be limited to the active storage capacity of the reservoir unless a past practice of refilling the reservoir during the water year (October 1 to September 30) is shown or if the claim is for a licensed or decreed right that includes refill. If a past practice of refilling the reservoir is shown or if the claim is for a licensed or decreed right that includes refill, the total amount of water claimed for the calendar year and the entire period during which diversion to storage or impoundment occurs shall be indicated.~~

(3-18-22)()

~~iii. The amount of water claimed for each purpose for which water is claimed shall not exceed the amount of water beneficially used for the purpose claimed, and the period of use for each purpose claimed shall not exceed the period in which water is beneficially used for the purpose claimed.~~

(3-18-22)

~~iv. The amount of water diverted shall be listed in cfs, and the amount of water stored shall be listed in af per annum.~~

(3-18-22)

~~g. Quantity of Water. ()~~

~~i. Include the flow rate in cfs or the volume of water to be stored in af per year for each purpose of use, using values with a maximum of three significant figures with no more precision than hundredths for rate and tenths for volume. ()~~

()

~~ii. For claims to store water, the maximum af per year may not exceed the storage facility capacity unless the claim includes a description explaining the past practice of filling the storage facility more than once per year, or the claim is for a licensed or decreed right that includes refill. The description of past refill practices may include refills to replace seepage, evaporation, or use from storage. ()~~

()

~~iii. The amount of water claimed for each purpose for which water is claimed must not exceed the amount of water beneficially used for the purpose claimed. ()~~

()

~~iv. Amount of Water Claimed. The total amount of water claimed shall be listed at item seven (7) of the form. The total amount of water claimed shall must not exceed the sum total of the amounts quantity listed at item six (6) of the form for each water use, or the total diversion capacity of the diversion system, whichever is less.~~

(3-18-22)()

~~h. Period of Use. A period of use must be listed for each purpose of use and must include the month and day of the first and last day of use. ()~~

()

~~hi. Description of Non-Irrigation Uses. Fully describe any Non-irrigation uses shall be fully described at item eight (8) of the form. For Domestic uses, must describe the number of households served shall be described; for s and any irrigation associated with the domestic use. Stock watering uses, must describe the type of stock and number of each type of stock shall be described. (3-18-22)()~~

(3-18-22)()

~~i. If the claimant's domestic use does not meet the definition of domestic use in Subsection 010-07, the form will be rejected and returned unless the appropriate variable fee is paid. (3-18-22)~~

~~ii. The claimant shall also state whether Claims for stock watering use must identify if the stock watering use is in-stream; or whether if water is diverted from the source for stock watering. Both types of In-stream livestock use and diverted stock watering cannot be filed on the same claim form; each type requires a separate claim unless the claim is for in-stream livestock use for which a "Notice of Diversion as an Alternative to Instream Stockwater Use" has been filed pursuant to Section 42-113, Idaho Code. (3-18-22)~~

~~iii. Describe Domestic use for organization camps and public campgrounds shall be fully described, including, but not limited to, the number of camp units, water faucets, flush toilets, showers, and sewer connections. Description of domestic use for organization camps and public campgrounds shall must also include the average and peak number of individuals using the facility, and the periods when peak or average rates of usage occur. (3-18-22)()~~

~~ij. Place of Use. Describe the location of the place of use to the nearest forty (40) acre tract or government lot and include township number (including north or south designations), range number (including east or west designations), section number, and county. The place of use for each purpose for which water is claimed shall be listed at item nine (9) of the form, except that the place of use for in-stream flows for public purposes need not be listed if the place of use is fully described as the stream between the beginning and ending points listed as the points of diversion. (3-18-22)()~~

~~i. Except claims for irrigation projects and irrigation districts meeting the criteria described in Subsection 060. 03.j.ii. below describe, the number of acres irrigated shall be described by entering the appropriate numbers in the appropriate boxes for to the nearest whole acre in each forty (40) acre tract or government lot on the form. For other uses, a symbol or letter corresponding to the purpose for which water is claimed shall be placed in the appropriate box for each forty (40) acre tract or government lot on the form. For irrigation of less than ten (10) acres, acreage must be shown to the nearest one-tenth (0.1) acre. (3-18-22)()~~

~~ii. Claims for an irrigation project where the canals constructed cover an area of twenty-five thousand (25,000) acres or more, or irrigation districts organized and existing as such under the laws of the state of Idaho, or for beneficial use by more than five (5) water users in an area of less than twenty-five thousand (25,000) acres shall must be accompanied by a map showing the boundaries of the project or irrigation district; and shall must state the total number of acres irrigated within the boundaries of the project or irrigations district. The project or district shall submit a map of the boundary of the place of use and, w When available, claims should include a digital boundary defined in Section 42-202(B)(2), Idaho Code. (3-18-22)()~~

~~iii. The claimant shall also list Include the Parcel Number or Parcel Identification Number (PIN) as assigned by the county assessor's office for the parcel where the water is used unless no Parcel Number or PIN is recorded for the property at the place of use or the PIN is the same as the PIN shown in item four (4) for the point of diversion. (3-18-22)()~~

~~jk. County of Place of Use. The List the county(ies) in which the place(s) of use is(are) located shall be listed at item ten (10) of the form. (3-18-22)()~~

~~kl. Authority to Assert Claim. The claimant shall indicate at item eleven (11) of the form Indicate whether the claimant is the owner of the place(s) of use. If the claimant is not the owner of the place(s) of use, the claimant shall describe in the remarks section of the form the claimant's authority to assert the claim. Unless the claimant is a water delivery organization, the claimant shall also state include the name and; address, and phone number of the owner(s) of the place of use in item thirteen (13) (remarks section) of the form. (3-18-22)()~~

~~lm. Other Water Rights. The claimant shall d Describe at item twelve (12) of the form any other water rights used at the same place and for the same purpose as the water right claimed. If there are no other water rights used at the same place and for the same purpose as the right claimed, the claimant shall state "NA" or "none." Include the existing water right number or claim number, if known. (3-18-22)()~~

~~mi.~~ Remarks. ~~At item thirteen (13) of the form, t~~The claimant may submit any additional, relevant information not specifically requested. If the space provided on the claim form is ~~not~~ insufficient, remarks ~~shall~~ may be set forth on a separate piece of paper and attached to the form. All separate attachments must be specifically referenced in the remarks section of the claim form. (3-18-22)()

~~no.~~ Maps. ~~An~~ Include an aerial photograph, digital image, or USGS quadrangle map ~~shall be included~~ with the claim, unless the claim meets the definition of domestic use ~~and or~~ stock watering use as defined in Section 010, or unless the claim is submitted electronically through the ~~d~~Department's ~~online~~ claim filing website. Identify ~~The~~ point(s) of diversion, place(s) of use, and the water delivery system ~~shall be identified~~ on the aerial photograph, imagery, or USGS quadrangle map. (3-18-22)()

~~op.~~ Basis of Claim. ~~The~~ Include the basis of the claim ~~shall be indicated at item fourteen (14) of the form. If a~~ Include any water right number ~~has been~~ previously assigned by the ~~d~~Department to the water right claimed, ~~the water right number shall also be indicated. If a water right number has not been assigned and the claimed~~ water right is based upon a decree, ~~the claimant shall~~ that does not have a previously assigned water right number, list the title and date of the decree, the case number, and the court that issued the decree. ~~If the basis of claim is a beneficial use (also known as the constitutional method of appropriation), the claimant shall provide a short description of events or history of the development of the water right.~~ (3-18-22)()

~~pg.~~ Signature. Each claim must be signed by ~~the~~ each claimant, ~~at item fifteen (15) of the form, unless the claim is submitted electronically through the department's online claim filing website~~ submitted electronically by the claimant, or signed and submitted with evidence to show the signatory has authority to sign on behalf of the claimant. Each claimant, ~~through submission of a signed claim or through submission of a claim by means of the department's online claim filing website,~~ solemnly swears or affirms under penalty of perjury that the statements contained in the notice of claim are true and correct. (3-18-22)()

i. ~~For claims submitted through the department's online claim filing website, the form shall be submitted by a person listed as the claimant at item one (1) of the form unless the person submitting the form has authority to submit the form for the claimant or claimants. Claims~~ A claim by a corporations, municipalities or other organizations ~~shall~~ must be submitted by an officer of the corporation or an elected official of the municipality or an individual authorized by the organization to submit the form. The signatory's title must be stated with the signature. (3-18-22)()

ii. ~~For claims that are not submitted by means of the internet, the form must be signed by each of the persons listed as claimants at item one (1) of the form unless the signatory has authority to sign for the claimant or claimants. Claims by corporations, municipalities or other organizations shall be signed by an officer of the corporation or an elected official of the municipality or an individual authorized by the organization to sign the form. The signatory's title shall be indicated with the signature.~~ (3-18-22)

~~qr.~~ Notice of Appearance. ~~If~~ An attorney submitting a claim on behalf of their client must include a notices ~~to be sent by the director to the claimant are to be sent to the claimant's attorney, the claimant's attorney shall~~ of appearance listing the attorney's name and address ~~and sign and date the form at item sixteen (16) of the form.~~ (3-18-22)()

~~034.~~ State Law Claim Form — Insufficient Claims, and Waivers. (3-18-22)()

a. Claims A claim filed on the state law claim form that does not contain the information required by Subsection 060.023 ~~shall~~ may be rejected and returned along with any fees paid, unless otherwise provided by these rules. (3-18-22)()

b. The ~~d~~Director may waive the minimum information requirements of Subsection 060.023 and accept the claim for good cause shown. (3-18-22)

~~04.~~ Further Information. This Rule Section 060 sets forth minimum requirements for the filing of a claims. The ~~d~~Director may request further information in support of the assertions contained in a claim as part of the investigation of the water system and the claims pursuant to Section 42-1410, Idaho Code. (3-18-22)()

061. -- 064. (RESERVED)

065. REJECTED AND RETURNED CLAIMS.

01. Rejected Claims. ~~Rejected claims shall be returned~~ The Department may return a rejected claim, or a copy of a generated claim record for claims filed electronically, to the claimant by ordinary mail at the most recent address shown by ~~e~~Department records. ~~The rejected claim shall be accompanied by,~~ with a notice of rejection that states generally the reason~~(s)~~ for rejection. ~~(3-18-22)()~~

02. Refiled Claims. ~~Claims that have been rejected and returned to the e~~ Claimants may ~~be~~ refiled rejected claims with the appropriate fees and appropriate information at any time prior to the deadline for filing the original claim. Claims refiled after the deadline for filing the original claim will be subject to the late fee, unless the claim is refiled within thirty (30) days from the date of mailing the rejected claim by the ~~e~~Department. ~~(3-18-22)()~~

066. -- 999. (RESERVED)

IDAPA 37 – IDAHO DEPARTMENT OF WATER RESOURCES

37.03.02 – BENEFICIAL USE EXAMINATION RULES

DOCKET NO. 37-0302-2401 (ZBR CHAPTER REWRITE)

NOTICE OF RULEMAKING – PROPOSED RULE

AUTHORITY: In compliance with Section 67-5221(1), Idaho Code, notice is hereby given that this agency has initiated proposed rulemaking procedures. The action is authorized pursuant to Section(s) § 1805(8), Idaho Code.

PUBLIC HEARING SCHEDULE: Public hearing(s) concerning this rulemaking will be scheduled if requested in writing by twenty-five (25) persons, a political subdivision, or an agency, not later than October 16, 2024.

The hearing site(s) will be accessible to persons with disabilities. Requests for accommodation must be made not later than five (5) days prior to the hearing, to the agency address below.

DESCRIPTIVE SUMMARY: The following is a nontechnical explanation of the substance and purpose of the proposed rulemaking:

The Idaho Department of Water Resources (IDWR) proposes a new chapter of the “Beneficial Use Examination Rules of the Idaho Department of Water Resources,” IDAPA 37.03.02, consistent with [Executive Order 2020-01](#). The new chapter reduces the length of the rule by 17% due to the removal of unnecessary or obsolete language and modifications that simplify and clarify language. Changes to the rule come through a combination of IDWR analysis and stakeholder negotiation and comments.

The development of the proposed rule text including public participation in meetings and comments can be viewed at: <https://idwr.idaho.gov/legal-actions/rules/idwr-rulemaking-2024-2025/beneficial-use-exam-rules/>. On the same website, IDWR also developed and published rulemaking support documents, which provide IDWR’s recommendations on rulemaking, rulemaking analysis, and responses to substantive comments received through the negotiated rulemaking process.

Citizens of the state of Idaho, water users, governmental agencies, and environmental groups may be interested in commenting on the proposed rule text. After consideration of public comments received in response to this Proposed Rule, IDWR will present the final rule text to the Idaho Legislature in 2025.

FEE SUMMARY: The following is a specific description of the fee or charge imposed or increased:

The rule governs the certification of water right examiners, the filing of proof of beneficial use, and beneficial use examination reports as well as the collection of fee for the same pursuant to Sections §§ 42-217, 42-217a, 42-218a, and 42-221K, Idaho Code.

FISCAL IMPACT: The following is a specific description, if applicable, of any negative fiscal impact on the state General Fund greater than ten thousand dollars (\$10,000) during the fiscal year resulting from this rulemaking: N/A

NEGOTIATED RULEMAKING: Pursuant to Section 67-5220(1), Idaho Code, negotiated rulemaking was conducted. The Notice of Intent to Promulgate Rules - Negotiated Rulemaking was published in the April 3, 2024 Idaho [Administrative Bulletin](#), Vol. 24-4, pages 52-53.

INCORPORATION BY REFERENCE: Pursuant to Section 67-5229(2)(a), Idaho Code, the following is a brief synopsis of why the materials cited are being incorporated by reference into this rule: N/A

ASSISTANCE ON TECHNICAL QUESTIONS, SUBMISSION OF WRITTEN COMMENTS: For assistance on technical questions concerning the proposed rule, contact Erik Boe at rulesinfo@idwr.idaho.gov, or 208-287-4800. Anyone may submit written comments regarding this proposed rulemaking. All written comments must be directed to the address below or by email to rulesinfo@idwr.idaho.gov and must be delivered on or before October 23, 2024.

DATED this 30th day of August, 2024.

Erik Boe, Water Compliance Bureau Chief, Rules Regulation Officer
Idaho Department of Water Resources
322 E. Front Street
PO Box 83720 Boise, ID 83720-0098
Phone: (208) 287-4800

THE FOLLOWING IS THE PROPOSED TEXT OF DOCKET NO. 37-0302-2401
(ZBR Chapter Rewrite)

37.03.02 – BENEFICIAL USE EXAMINATION RULES

000. LEGAL AUTHORITY ~~(RULE 0)~~.

The ~~d~~Director of the Department of Water Resources adopts these rules under the authority provided by Sections ~~42-217a and~~ 42-1805(8), Idaho Code. (3-18-22)()

001. TITLE AND SCOPE ~~(RULE 1)~~.

~~Sections 42-217 and 42-221, Idaho Code, requires a license examination fee be submitted together with the written proof of beneficial use or that a field examination report prepared by a certified water right examiner be submitted together with the written proof of beneficial use. The statutes also provided that field examinations could be conducted by certified water right examiners appointed by the director.~~ These rules set the procedures for appointing certified water right examiners and govern beneficial use examinations and the filing of beneficial use examination reports. (3-18-22)()

01. Examination Requirements. The ~~examination~~ requirements listed are intended ~~as a guide~~ to establish acceptable standards to determine the extent of application of water to beneficial use. The requirements are not intended to restrict the application of other sound examination principles by water right examiners. The ~~d~~Director will evaluate any deviation from the standards hereinafter stated as they pertain to the review of any given examination. ~~W~~ Certified water right examiners are encouraged to submit new ~~ideas~~ techniques which will advance the ~~art~~ practice of examination and ~~provide~~ for the public benefit. (3-18-22)()

02. Rules. These rules shall not be construed to deprive or limit the ~~d~~Director ~~of the Department of Water Resources~~ of any exercise of powers, duties, and jurisdiction conferred by law, nor to limit or restrict the amount or character of data, or information which may be required by the ~~d~~Director from any owner of a water right permit or authorized representative for the proper administration of the law. (3-18-22)()

002. -- 008. (RESERVED)

009. APPLICABILITY ~~(RULE 9)~~.

01. Proof of Beneficial Use. These rules apply to all permits for which proof of beneficial use is not yet due and has not been submitted to the ~~d~~Department. (3-18-22)()

02. Examination. These rules apply to all permits for which an examination has not been conducted. (3-18-22)

03. Re-Examination. These rules apply to all permits that have been examined but the license has not been issued due to a request for a re-examination by the permit holder. (3-18-22)

04. Examination Fee. The examination fee requirements of these rules do not apply to a permit for

ground water use for single family domestic use, stockwatering, or any other small uses for which the use does not exceed four one hundredths (0.04) cfs or four (4) AF/year a permit is not required by statute. The examination fee is required for multiple use permits which exceed four one-hundredths (0.04) cfs or four (4) AF af/year even though single family domestic use or stockwater use is included as one (1) of the uses on the permit. (3-18-22)()

010. DEFINITIONS (RULE 10).

~~Unless the context otherwise requires, the following definitions govern these rules.~~ (3-18-22)

01. Acre-Foot (AFaf). A volume of water sufficient to cover one (1) acre of land one (1) foot deep and is equal to ~~forty three thousand, five hundred sixty (43,560) cubic feet~~ three hundred twenty-five thousand, eight hundred fifty (325,850) gallons. (3-18-22)()

~~02. Acre-Foot/Annum. An annual volume of water that may be diverted under a given use or right.~~ (3-18-22)

~~032. Amendment.~~ A change in to the point of diversion, place, period, ~~or~~ nature of use, or other substantial change in the method of diversion or use of a permitted water right. (3-18-22)()

03. Beneficial Use Examination (Examination). An on-site inspection or other investigation to determine the extent of application of water to beneficial use and to determine compliance with terms and conditions of the water right permit. ()

04. Beneficial Use Examination Report (Examination Report). The form provided by the Department or other acceptable document upon which the CWRE or Department employee records the data required by Section 035 gathered during the examination. ()

045. Capacity Measurement. The maximum volume of water impounded in the case of ~~reservoirs a~~ storage facility or the maximum rate of diversion from the source as determined by actual measurement of the system during normal operation. (3-18-22)()

~~056. Certified Water Right Examiner (CWRE). A professional engineer or professional geologist, qualified and registered in the state of Idaho who has the knowledge and experience necessary to satisfactorily complete water right field examinations as determined by the Director, and who has been appointed by the Director, Idaho Department of Water Resources as a certified water right examiner. A certified water right examiner is commonly termed a field examiner, water right examiner or examiner. A certified water right examiner is a~~ An impartial investigator and reporter of the information required appointed by the Director in accordance with Section 030 to determine the extent of beneficial use established in compliance with a permit. Department employees are authorized to conduct water right examinations at the discretion of the Director. (3-18-22)()

~~067. Conveyance Works.~~ The ditches, pipes, conduits, or other means by which water is carried or moved from the point of diversion to the place of use. ~~Storage works, if any.~~ Any storage structure, such as a dam, ~~can be is~~ considered part of the conveyance works. (3-18-22)()

078. Cubic Foot Per Second (CFScfs). A rate of flow approximately equal to four hundred forty-eight and eight tenths (448.8) gallons per minute and also equals fifty (50) Idaho miner's inches. (3-18-22)()

089. Department. The Idaho Department of Water Resources. (3-18-22)

~~0910. Director.~~ The Director of the Idaho Department of Water Resources. Per Section 42-1701(3), Idaho Code, the Director may delegate authority to perform duties imposed upon the Director by law, including duties described herein, to a Department employee. (3-18-22)()

11. Diversion Works. The constructed barriers or devices on the source of water by which water can be diverted from the natural watercourse. ()

102. Duty of Water. The quantity of water necessary for the successful growing of crops when economically ~~conducted~~ conveyed and applied to land without unnecessary loss ~~as will result in the successful~~

growing of crops. (3-18-22)()

~~11. Examination or Field Examination.~~ An on-site inspection or investigation to determine the extent of application of water to beneficial use and to determine compliance with terms and conditions of the water right permit. (3-18-22)

~~12. Field Report.~~ The form provided by the Department upon which the examiner records the data gathered and describes the extent of diversion of water and application to beneficial use. The report is fully termed beneficial use field report and is also termed a field examination report. (3-18-22)

~~13. Headworks or Diversion Works.~~ The constructed barriers or devices on the source of water (surface water or ground water) by which water can be diverted from its natural course of flow and/or measured. (3-18-22)

13. Irrigation. The application of water to cultivated land in sufficient quantity or manner to cause plant growth for a useful purpose. ()

14. License. The certificate issued by the Director in accordance with Section 42-219, Idaho Code confirming the extent of diversion and beneficial use of the water ~~that has been~~ made in conformance with the permit conditions. (3-18-22)()

15. License Examination Fee. The fee ~~required~~ prescribed in Section 42-221(K), Idaho Code, ~~and is also termed an examination fee.~~ (3-18-22)()

16. Legal Subdivision. A tract of land described by ~~the a~~ government land survey and usually ~~is~~ described by government lot or quarter-quarter, section, township, and range. A lot and block of a subdivision plat recorded with the county recorder may be used in addition to the government ~~lot, quarter-quarter, section, township and range~~ land survey description. (3-18-22)()

17. Measuring Device. A generally accepted structure or apparatus used to determine a rate of flow or volume of water. ~~Examples are weirs, meters, and flumes. Less typical devices may be accepted by the Director on a case by case basis.~~ (3-18-22)()

18. Nature of Use. The ~~characteristic~~ purpose of use for which water is applied. ~~Examples are domestic, irrigation, mining, industrial, fish propagation, power generation, municipal, etc.~~ (3-18-22)()

19. Period of Use. The ~~time~~ period during which water under a given water right can be beneficially used. (3-18-22)()

20. Permit Holder or Owner. The person, association, or corporation to whom a permit has been issued or ~~assigned~~ conveyed as shown by the records of the Department. (3-18-22)()

~~21. Permit or Water Right Permit.~~ The water right document issued by the Director authorizing the diversion and use of unappropriated public water of the state or water held in trust by the state. (3-18-22)

~~21.~~ Place of Use (~~P.U. or~~ POU). The location where ~~the~~ beneficial use of appropriated water is made of the diverted water. (3-18-22)()

~~22.~~ Point of Diversion (~~P.D. or~~ POD). The location on the public source of water from which water is diverted. ~~Examples are pump intake, headgate, well locations, and dam locations.~~ (3-18-22)()

23. Project Works. A general term ~~which that~~ includes diversion works, conveyance works, and any devices ~~which may be~~ used to measure ~~the~~ water or to apply ~~the~~ water to the intended use. ~~Improvements which have been made as a result of application of water, such as land preparation for cultivation, are not a part of the project works.~~ (3-18-22)()

~~24.~~ Proof of Beneficial Use (Proof). The submittal required in Section 42-217, Idaho Code. ~~This~~

~~submittal is commonly termed proof.~~ (3-18-22)()

~~265. Source.~~ The name of the natural water body at the point of diversion. ~~Examples are Snake River, Smith Creek, ground water, spring, etc.~~ (3-18-22)()

~~26. Water Right Permit (Permit).~~ The water right document issued by the Director authorizing the diversion and use of unappropriated public water, reallocated trust water, or a low temperature geothermal resource. ()

~~011. ABBREVIATIONS.~~

~~01. AF.~~ Acre Foot or Acre Feet. (3-18-22)

~~02. CFS.~~ Cubic Foot Per Second. (3-18-22)

~~03. P.D. or POD.~~ Point of Diversion. (3-18-22)

~~04. P.U. or POU.~~ Place of Use. (3-18-22)

~~05. USGS.~~ United States Geological Survey. (3-18-22)

~~0121. -- 024. (RESERVED)~~

~~025. AUTHORITY OF REPRESENTATIVE (RULE 25).~~

~~01. Proof of Beneficial Use~~ Evidence of Authority. When the proof of beneficial use, ~~field examination~~ report, and drawings are filed by ~~the water right examiner~~ a CWRE on behalf of an owner, written evidence of authority to represent the owner shall be filed with the proof, ~~field report, and drawings.~~ (3-18-22)()

~~02. Responsibility.~~ It is the responsibility of the permit holder or authorized representative to submit proof ~~of beneficial use~~ and ~~provide for the timely~~ ensure submission of a completed ~~field examination~~ report in acceptable form to the Director ~~by before~~ the due date ~~in acceptable form to the director~~ by either paying the required examination fee to the ~~d~~Department or by employing a ~~certified water right examiner~~ CWRE. (3-18-22)()

~~026. -- 029. (RESERVED)~~

~~030. QUALIFICATION, EXAMINATION AND APPOINTMENT OF CERTIFIED WATER RIGHT EXAMINER (RULE 30).~~

~~01. Consideration.~~ Any professional engineer or geologist qualified and registered in the state of Idaho ~~who has with~~ the knowledge and experience necessary to satisfactorily complete ~~water right field examinations~~ an examination as determined by the Director shall be considered for appointment as a ~~water right examiner~~ CWRE upon application to the Director. The application shall be in the form prescribed by the Director and shall be accompanied by a non-refundable fee in the amount ~~provided by statute~~ prescribed in Section 42-217a, Idaho Code. (3-18-22)()

~~02. Information.~~ The Director may require an applicant for appointment to the position of ~~water right examiner~~ CWRE to provide detailed experience information ~~of past experience, provide~~ submit references, and ~~to~~ satisfactorily complete a written or oral examination. (3-18-22)()

~~03. Denial.~~ If the Director determines an applicant is not qualified, the application will be denied. If the Director determines an applicant is qualified, a certificate of appointment will be issued. (3-18-22)

~~04. Expiration.~~ Every ~~water right examiner~~ CWRE certificate of appointment shall expire March 31 of each year unless renewed by application in the manner prescribed by the Director. A non-refundable fee in the amount ~~provided by statute~~ prescribed in Section 42-217a, Idaho Code, shall accompany an application for renewal.

(3-18-22)()

05. Refusal or Revocation. An appointment or renewal may be refused or revoked by the Director at any time upon a showing of reasonable cause. A party aggrieved by an action of the Director may request an administrative hearing pursuant to Section 42-1701A (3), Idaho Code. (3-18-22)

06. Reconsideration. An application for appointment or renewal which has been refused or revoked by the Director may not be reconsidered for six (6) months. (3-18-22)

07. Liability. The state of Idaho shall not be liable for the compensation of any ~~water right examiner other than department employees.~~ CWRE. The permit holder shall be responsible for costs associated with proof submittal including examination and field examination report preparation. (3-18-22)()

08. Examinations. The Director may authorize sufficiently knowledgeable and experienced ~~d~~Department employees to conduct ~~water right~~ examinations during the course and scope of their employment with the ~~d~~Department. Upon termination of employment with the ~~d~~Department, such examiners, unless ~~re~~appointed as a ~~non department certified examiner~~ CWRE under provisions of these rules, are not authorized to conduct ~~field~~ examinations. ~~The fee provisions of these rules do not apply to department employees.~~ (3-18-22)()

09. Ingress or Egress Authority. Appointment as a ~~water right examiner~~ CWRE does not grant ingress or egress authority ~~to non department examiners~~ and does not convey authority unless explicitly prescribed in these rules. (3-18-22)()

10. Reports. The Director will not accept ~~a field an~~ examination report prepared by a ~~certified water right examiner~~ CWRE or a ~~d~~Department ~~employee examiner~~ who has any past or present interest, direct or indirect, in either the water right permit, the land, or any enterprise benefiting, or likely to benefit, from the water right. ~~Among those that t~~ The Director will presume ~~to have~~ an actual or potential conflict of interest exists and ~~from whom he~~ will not accept ~~a field an~~ examination report ~~are from~~ the following: (3-18-22)()

a. The person ~~or persons~~ owning the water right permit or the land or enterprise benefiting from the water right permit, members of their ~~families~~ family (spouse, parents, grandparents, lineal descendants including those that are adopted, lineal descendants of parents; and spouse of lineal descendants), and their employees. (3-18-22)()

b. The person ~~or persons~~, who sold or installed the diversion project works ~~or distribution system~~. (3-18-22)()

11. Money Received. All moneys received by the ~~d~~Department under the provisions of these rules shall be deposited in the water administration ~~fund~~ account created under Section 42-238a, Idaho Code. (3-18-22)()

031. -- 034. (RESERVED)

035. EXAMINATION FOR BENEFICIAL USE ~~(RULE 35)~~.

01. Field Examination Report. An examination report must include the following information in sufficient detail for the Director to determine the extent of water use developed consistent with the permit: (3-18-22)()

~~a.~~ All items of the field report must be completed and must provide sufficient information for the Director to determine the extent of the water right developed in order for the report to be acceptable to the Director. (3-18-22)

~~ba.~~ Permitted uses ~~Each permitted use developed or~~ partially developed, ~~by the permit holder shall be described in detail. Permitted uses which were not developed by the permit holder~~ Note any undeveloped permitted use shall be noted. Uses determined to exist which are and describe any established use that is not authorized by the permit being examined ~~shall also be described in detail.~~ (3-18-22)()

~~eb.~~ The location for the POD described by legal subdivision, including a concise description of the diversion works and a general description of the ~~distribution conveyance~~ works, ~~shall be given. This~~ The description must trace the water from the ~~point of diversion POD~~ to the ~~place of use POU, and the return to a public water source, if any. Any reservoir, diversion dam, headgate, well, canal, flume, pump and other related structure shall be included.~~ If water is stored, describe the timing ~~and of storage~~, method of storage, release, redirection, and conveyance to the ~~place of use POU shall be described. The~~ Describe the make, capacity, serial number, and model number of all pumps, boosters or measuring devices associated with the ~~point of diversion POD~~ at the source of the water supply, ~~shall be described on the field examination report. Schematic~~ Include any schematic diagrams, photographs, digital images, and maps sufficient to locate and describe the diversion, conveyance, and usage systems ~~shall also be provided in the examination report.~~ (3-18-22)()

~~ec.~~ Any interconnection of ~~the water use being examined~~ with an other water rights or ~~with other~~ conveyance systems ~~shall be described on the field report.~~ Interconnection includes, but is not limited to, sharing the same ~~point of diversion POD~~, distribution system, ~~place of use POU~~, or beneficial use. The examination report shall ~~also~~ include an evaluation ~~of how that demonstrates~~ the water use ~~being examined~~ is distinct from ~~prior other~~ existing water rights, ~~and provides is~~ an alternate source of water for a beneficial use served by an existing water right, or is an increment of beneficial use not authorized by ~~prior another~~ existing water rights. (3-18-22)()

~~ed.~~ If water is returned directly to a public water source after use, a description of the conveyance system and the legal description of the point where the water is returned, ~~and source to which discharge is made shall be provided. Examples of uses which generally have an effluent discharge include fish propagation and power facilities.~~ (3-18-22)()

~~ef.~~ The method of compliance with each permit condition of approval, ~~of a permit shall be shown on the field report by the examiner.~~ (3-18-22)()

~~eg.~~ The POU location for each use described by legal subdivision. ()

~~i.~~ For irrigation, describe the irrigated acreage to the nearest whole acre in each forty (40) acre legal subdivision. For irrigation of less than ten (10) acres, describe the acreage to the nearest one-tenth (0.10) acre. ()

~~ii.~~ If the water is used for irrigation, the ~~For irrigation, submit a map depicting the~~ boundaries of the irrigated areas and the project works location ~~of the project works providing that conveys~~ water to each area, ~~shall be platted on the maps submitted with the report and the~~ Show the full or partial acreage in each legal subdivision of forty (40) acres or government lot ~~shall be shown.~~ (3-18-22)()

~~h.~~ Irrigated acreage shall be shown on the field report to the nearest whole acre in a legal subdivision except the acreage shall be shown to the nearest one-tenth (0.10) acre for permits covering land of less than ten (10) acres. (3-18-22)

~~ig.~~ Where a permit has been developed as separate distribution systems from more than one point of diversion, the separate areas irrigated from each point of diversion shall be shown on the maps submitted with the report and the legal subdivisions embracing the irrigated areas for each such respective point of diversion together with the total irrigated area shall be described. If more than one (1) POD is developed with separate diversion works and conveyance works, a description of each separate system. For irrigation, submit a map depicting the boundary of irrigated acres and the number of acres per legal subdivision for each separate system. (3-18-22)()

~~jh.~~ For each use of water the examiner shall report an ~~The~~ annual diversion volume based on actual beneficial use during the development period ~~for the permit for each permitted use. The~~ Describe the method ~~of used~~ for determining the annual diversion volume ~~shall be shown.~~ The annual diversion volume shall account for seasonal variations in factors affecting water use, including seasonal variations in water availability. ~~For irrigation, the volume shall be based on the field headgate requirements in the map titled Irrigation Field Headgate Requirement appended to these rules (see Appendix A located at the end of this chapter). Annual diversion volumes for heating and cooling uses may be adjusted to account for documented weather conditions during any single heating or cooling season from among the fifty (50) years immediately prior to submitting proof of beneficial use for the permit. For storage uses that~~

~~include filling the reservoir and periodically replenishing evaporation and seepage losses throughout the year, the annual diversion volume shall be the sum of the amounts used for filling and for replenishment. Volumes may include reasonable conveyance losses actually incurred by the water user. The following water uses are exempt from the volume reporting requirement:~~ (3-18-22)(____)

~~i. For irrigation, the volume shall be based on the standard field headgate requirement as determined by the Director. The Department established irrigation standard field headgate requirement is available on the Department's website or from the Department upon request.~~ (____)

~~ii. For heating, cooling, or commercial snowmaking, the volume may be adjusted to account for documented weather conditions during any single season from among the fifty (50) years immediately prior to submitting proof for the permit.~~ (____)

~~iii. For storage use that includes refill, a use from storage, or both, the volume shall be the sum of the amount used for fill and in priority refill. If the volume exceeds the capacity of the storage facility, describe the amount, method, and timing of refill.~~ (____)

~~i. The following water uses are exempt from the volume reporting requirement:~~ (____)

~~i. Diversion to storage. (Volume should be reported for the storage use, such as irrigation storage.)~~ (3-18-22)(____)

~~ii. Domestic uses from ground water as defined in Section 42-111, Idaho Code.~~ (3-18-22)(____)

~~iii. In-stream watering of livestock.~~ (3-18-22)

~~iv. Fire protection. (Volume is required for fire protection storage.)~~ (3-18-22)

~~v. On-stream, run-of-the-river, non-consumptive on-stream power generation uses.~~ (3-18-22)(____)

~~vi. Minimum stream flows established pursuant to Chapter 15, Title 42, Idaho Code.~~ (3-18-22)

~~vii. Municipal use by an incorporated city or other entity serving users throughout an incorporated city; a municipal provider as defined in Section 42-202B(5), Idaho Code that is serving users within a municipality's service area as defined in Section 42-202B(9), Idaho Code, except the following situations that do require a volume to be reported:~~ (3-18-22)(____)

~~(1) The permit or amended permit was approved with a volume limitation; or~~ (3-18-22)

~~(2) The permit was not approved for municipal use but can be amended and licensed for a municipal use established during the authorized development period for the permit.~~ (3-18-22)

~~viii. Irrigation using natural stream flow diverted from a stream or spring. (Volumes must be reported for irrigation uses from ponds, lakes and ground water and for irrigation storage and irrigation from storage.)~~ (3-18-22)

~~ix. For fish propagation, the total number of holding/rearing ponds and the dimensions and volume of the ponds shall be shown on the field report for fish rearing or fish propagation use each pond. The annual volume shall be calculated based on the changes of water per hour.~~ (3-18-22)(____)

~~x. Information shall be submitted concerning Description of the beneficial use that has been made of the water unless the purpose of use is for irrigation for all non-irrigation use. For example, for stockwater use, the number and type of stock watered shall be provided. Similar indications of the extent of beneficial use shall be provided for all other non-irrigation uses.~~ (3-18-22)(____)

~~xi. The period during each year that the water is used shall be described for each permitted use.~~ (3-18-22)(____)

~~nm.~~ For permits having more than one (1) use, ~~t~~The diversion rate measured for each use, ~~the annual diversion volume determined for each use (unless specifically exempted by rule or statute), and the place of use for each use shall be described.~~ The diversion rate measured for each use, the annual diversion volume determined for each use (unless specifically exempted by rule or statute), and the place of use for each use shall be described. (3-18-22)()

~~on.~~ The amount ~~(rate and/or volume)~~ of water ~~shall~~ will be limited by the smaller of the permitted amount, the amount upon which the license examination fee is paid, the capacity of the diversion works or the amount beneficially used prior to submitting proof of beneficial use, including any statutory limitation of the duty of water. (3-18-22)()

~~po.~~ ~~Suggested amendments~~ Amendment recommendations based on actual use shall be noted on the field report when if the place of use POU, point of diversion POD, period of use, or nature of use is different from the permit. Suggested amendments shall be based on actual use, not on potential use. (3-18-22)

~~qp.~~ An aerial photo marked to depict the point(s) of diversion and place(s) of use for each use must accompany each field report A map consistent with Subsection 045.03 unless waived by the Director. ~~If existing photos are not available, the Director will accept a USGS Quadrangle map at the largest scale available.~~ (3-18-22)()

~~rg.~~ Unless required as a condition of permit approval, an on-site examination and direct measurement of the diversion rate ~~are is~~ not required for the following water uses if the extent of beneficial use, place of use, season of use, and point of diversion can be confirmed by documentary means such as well driller reports, property tax records, receipts ~~and other records of the permit holder, or~~ photographs, ~~including aerial photographs~~ imagery, or other records: (3-18-22)()

i. Irrigation up to five (5) acres. (3-18-22)

ii. Storage of up to fourteen point six (14.6) ~~acre-feet~~ af of water ~~solely for stock watering purposes~~ stockwater, aesthetic, recreation, or wildlife. (3-18-22)()

iii. Any uses other than irrigation or storage if the total combined diversion rate for all the uses established in connection with the permit does not exceed twenty-four one hundredths (0.24) ~~cubic feet per second~~ cfs. (3-18-22)()

02. ~~Field~~ Examination Report Acceptability. (3-18-22)()

a. All ~~field examination~~ reports shall be prepared by or under the supervision of ~~certified water right examiners a CWRE~~ or authorized ~~d~~Department employees. ~~Reports~~ An examination report submitted by ~~certified water right examiners a CWRE~~ must be properly endorsed with ~~an the CWRE's~~ engineer or geologist seal and signature. ~~Field reports~~ An examination report received from ~~certified water right examiners a CWRE~~ will be accepted if the report includes all the information required ~~to complete the report and provides~~, including the information required by ~~Rule~~ Subsection 035.01. (3-18-22)()

b. ~~Field reports~~ An examination report not completed as required by these rules will be returned ~~to the certified water right examiner~~ for completion. ~~If the date for submitting proof of beneficial use has passed, t~~ The penalty provisions of ~~Rule Section~~ 055 ~~shall~~ will apply. (3-18-22)()

c. If the Director determines that ~~a field an examination~~ report prepared by a ~~certified water right examiner~~ CWRE is acceptable but ~~that~~ additional information is needed to clarify the ~~field examination~~ report, the Director will notify the ~~examiner~~ CWRE in writing of the information required. If the additional information is not submitted within thirty (30) days or within the time specified in the written notice, the Director will return the examination report and proof to the permit holder, priority date of the permit will be advanced one (1) day for each day the information submittal is late. Failure to submit the required information within one (1) year of the date of the ~~d~~Department's request is cause for the Director to take action to ~~cancel the permit~~ apply the provisions of Section 055. (3-18-22)()

d. ~~Field reports which indicate that~~ An examination report that indicates a measuring device or

lockable controlling works, required as a condition of approval of the permit, ~~has is not been installed, are or is~~ not acceptable ~~and~~ will be returned ~~to the examiner~~ unless the Director has formally waived the measuring device requirement or lockable controlling works requirement ~~has been formally waived or modified by the Director.~~
(3-18-22)(____)

03. General. (3-18-22)

a. For irrigation ~~purposes~~, the duty of water shall not exceed five (5) ~~acre feet af~~ of stored water for each acre of land to be irrigated or more than one (1) ~~cubic foot per second cfs~~ for each fifty (50) acres of land to be irrigated unless it can be shown to the satisfaction of the Director that a greater amount is necessary. (3-18-22)(____)

b. For irrigated acreage of five (5) acres or less, a diversion rate up to three one-hundredths (0.03) cfs per acre may be allowed on the license to be issued by the Director. (3-18-22)

c. Conveyance losses ~~of water~~ from the ~~point of diversion~~ POD to the ~~place of use~~ POU which are determined by actual measurement may be allowed ~~by the Director~~ if the diversion rate does not exceed the permitted rate and the loss is determined by the Director to be reasonable. (3-18-22)(____)

d. The duty of water described in ~~Subsections Paragraph~~ 035.03.a. or 035.03.b. may be exceeded if the ~~department has authorized~~ permit or amended permit was approved with a greater diversion rate per acre ~~when the permit was issued~~ and good cause acceptable to the Director has been demonstrated. (3-18-22)(____)

e. For irrigation, ~~systems which the irrigated areas may be generally described if the project works~~ cover twenty-five thousand (25,000) acres or more, are within irrigation districts organized and existing under the laws of the state of Idaho, ~~and for irrigation projects or were~~ developed under a permit held by an association, company, corporation, or the United States authorized to deliver surface water to more than five (5) water users under an annual charge or rental, ~~the field report does not need to describe the irrigated land by legal subdivision, but may describe generally the lands under the project works if and~~ the total irrigated acres ~~has been are~~ accurately determined and ~~is shown on in the field examination~~ report. The amount of water beneficially used under such projects must be shown ~~on in the field examination~~ report. (3-18-22)(____)

036. -- 039. (RESERVED)

040. WATER MEASUREMENT (~~RULE 40~~).

01. Measurement ~~Terminology~~. A rate of flow measurement shall be shown in units of cfs with three (3) significant figures and no more precision than hundredths. A volume measurement shall be shown in units of af with three (3) significant figures and no more precision than tenths. (3-18-22)(____)

~~a. Rate of flow measurements shall be shown in units of cubic feet per second (cfs) with three (3) significant figures and no more precision than hundredths. (3-18-22)~~

~~b. Volume measurements shall be shown in units of acre-feet (AF) with three (3) significant figures, and no more precision than tenths. (3-18-22)~~

02. Diversion Rate of Diversion. The ~~rate of~~ diversion rate measurement ~~shall must~~ be conducted as close as reasonably possible to the source of supply and ~~shall must~~ be measured with the project works fully in place operating at normal capacity. ~~For example, if a sprinkler system is used for irrigation purposes, discharge from the pump must be measured with the sprinkler system connected.~~ (3-18-22)(____)

03. Measurements. Water measurements may be made by vessel, weir, meter, rated flume, reservoir capacity table or other standard method of measurement acceptable to the Director. The field examination report ~~shall~~ must describe the method used in making the measurement, the date when made, the name of the person making the measurement, ~~the legal a~~ description of the location where the measurement was taken, and ~~shall~~ include sufficient information, including current meter notes, rating tables, ~~and/~~ or calibration information to enable the Director to check the quantity of water measured ~~in each case.~~ (3-18-22)(____)

04. Unacceptable Measurements. Theoretical diversion rates or theoretical carrying capacities are not acceptable as a measure of the ~~rate of~~ diversion ~~rate~~ except as indicated in these rules and for ~~some~~ diversion ~~systems~~ ~~works~~ where the flow rate cannot be measured accurately due to the physical characteristics of the diversion and distribution system. (3-18-22)()

05. Method. ~~R~~Flow ~~rate of flow~~ measurements shall be determined using equipment and methods capable of obtaining an accuracy of plus or minus ten percent (10%). (3-18-22)()

041. -- 044. (RESERVED)

045. DRAWINGS, MAP, AND SCHEMATIC DIAGRAM (RULE 45).

~~The following provisions shall apply to the submittal of drawings, maps, photos and the schematic diagrams.~~ (3-18-22)

01. Submittal of Drawings, Maps, Photos and Schematic Diagrams. Drawings, maps, photos and schematic diagrams used as an attachment to the ~~field examination~~ report ~~shall~~ should be on eight and one-half by eleven (8 1/2 x 11) inch paper whenever possible. (3-18-22)()

02. Attachment Sheets. ~~Attachment sheets shall d~~Depict information on one (1) side ~~only of attached documents.~~ (3-18-22)()

03. Scale of Map. ~~The map~~ An aerial image or United States Geological Survey Quadrangle map depicting the ~~point of diversion~~ POD and ~~place of use~~ POU ~~shall~~ must be of a reasonable scale ~~but not less than two (2) inches equals one (1) mile. The map shall~~ and show the location of the ~~point(s) of diversion~~ POU and POD to the nearest forty (40) acre tract ~~or to a ten (10) acre tract for springs.~~ The location of ~~ditches, canals, mainlines, distribution systems and the place of use by forty (40) acre tract~~ must any ditch, canal, mainline, or other conveyance work must be shown. (3-18-22)()

04. Drawings. Drawings ~~need to~~ must include a scale and generally depict the size and type of diversion works, measuring device, conveyance system, water application method, and the location of any measurements taken. (3-18-22)()

05. Photographs. Photographs of the diversion works, ~~the typical distribution~~ conveyance works, and other prominent features of the ~~system shall~~ project works must be ~~provided with the field~~ clearly labeled and attached to the examination report. (3-18-22)()

046. -- 049. (RESERVED)

050. LICENSE EXAMINATION FEE (RULE 50).

01. Examinations Conducted by Department Staff. (3-18-22)

a. The examination fee shall be payable to the Department ~~of Water Resources~~ unless the ~~field~~ examination is conducted by a ~~certified water right examiner~~ CWRE. (3-18-22)()

b. The ~~d~~Department will not conduct an examination for which the fee has not been paid to the ~~d~~Department unless exempted in ~~Rule~~ Subsection 009.04, except that for any prior examination, whether conducted by a ~~certified water right examiner~~ CWRE or by a ~~d~~Department ~~staff~~ employee, the department may conduct a supplemental examination on its own initiative at any time. No examination fee ~~shall~~ will be charged for a supplemental examination conducted by the ~~d~~Department on its own initiative. (3-18-22)()

c. ~~A license shall~~ The Department will not ~~be issued~~ issue a license for an amount of water in excess of the amount covered by the examination fee. Subsequent to the examination and prior to issuing a license ~~being issued~~, the Director will notify the permit holder that the licensed amount will be limited because an insufficient examination fee was paid. The permit holder will be allowed thirty (30) days after the notice is mailed to pay the additional examination fee, ~~along with a late payment penalty of twenty five dollars (\$25) or twenty percent (20%) of the amount of the additional required fee whichever is more.~~ If payment is received within the thirty (30) day period, the

~~Department will not reduce the~~ rate or volume licensed ~~shall not be reduced by reason of~~ based on the examination fee. If payment is not received within the thirty (30) day period, the Department will limit the rate or volume licensed ~~shall be limited by~~ based on the original examination fee paid. For the purpose of determining advancement of priority for late fees ~~as provided in accordance with in~~ Section 42-217, Idaho Code, fees ~~shall will~~ not be considered as having been paid until paid in full, including any subsequent fee. (3-18-22)()

d. Excess examination fees are non-refundable. (3-18-22)

e. An examination fee equal to the initial examination fee paid to the ~~e~~Department shall be paid for a re-examination made at the request ~~for of~~ the permit holder except upon a showing of error by the ~~e~~Department on the initial examination. (3-18-22)()

02. Examinations Conducted by ~~Non-Department~~ Certified Water Right Examiners. (3-18-22)()

a. The examination fee required by Section 42-217, Idaho Code is not applicable for an examination conducted by or under the supervision of ~~certified water right examiners~~ a CWRE. (3-18-22)()

b. A permit holder may not choose to have the examination conducted by the ~~e~~Department after selecting a ~~certified water right examiner~~ a CWRE. (3-18-22)()

c. After submitting proof of beneficial use and paying an examination fee to the ~~e~~Department, but before the ~~department's actual~~ examination, a permit holder may submit an examination report completed by a ~~certified water right examiner~~ CWRE. Because the examination fee is an essential component of timely proof submittal, the ~~e~~Department will not refund the examination fee. (3-18-22)()

051. -- 054. (RESERVED)

055. PENALTY (~~RULE 55~~).

01. Permits for Which Proof Has Not Been Submitted. The submittal required is the proof and the examination fee or the proof and ~~a completed field~~ an examination report completed by a CWRE. (3-18-22)()

02. Failure to Submit. Failure to submit either the license examination fee or an acceptable ~~field~~ examination report prepared by or under the supervision of a ~~certified water right examiner~~ CWRE by the proof due date is cause to lapse the permit pursuant to Section 42-218a, Idaho Code, unless the Department approved an extension of time pursuant to Section 42-204, Idaho Code, extending the proof of beneficial use due date ~~has been~~ approved. (3-18-22)()

056. -- 999. (RESERVED)

Appendix A

Appendix A

Irrigation Field Headgate Requirement

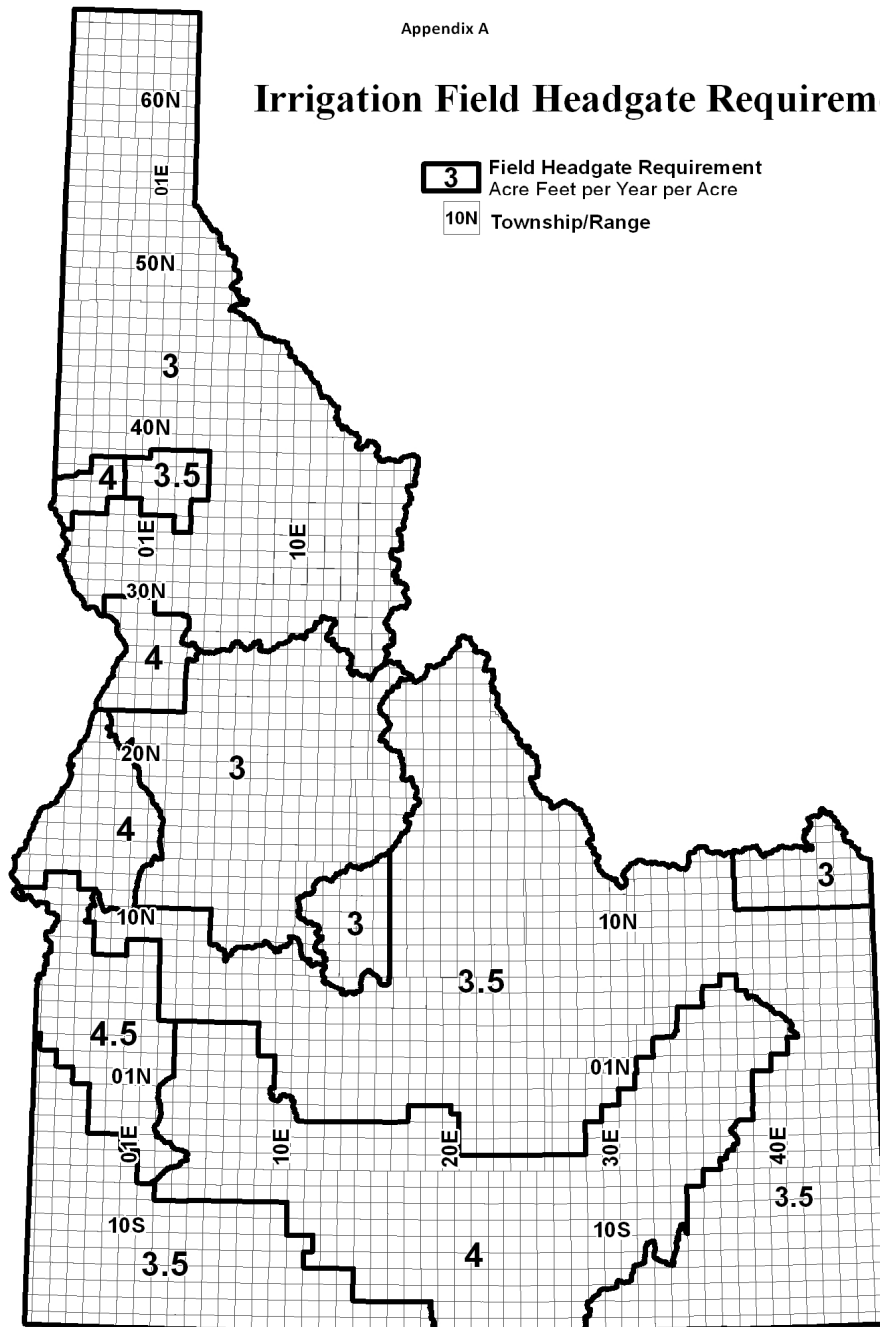

IDAPA 37 – IDAHO DEPARTMENT OF WATER RESOURCES
37.03.03 – RULES AND MINIMUM STANDARDS FOR THE CONSTRUCTION
AND USE OF INJECTION WELLS

DOCKET NO. 37-0303-2301 (ZBR CHAPTER REWRITE)

NOTICE OF RULEMAKING – PROPOSED RULE

AUTHORITY: In compliance with Section 67-5221(1), Idaho Code, notice is hereby given that this agency has initiated proposed rulemaking procedures. The action is authorized pursuant to Section 42-1805(8), Idaho Code.

PUBLIC HEARING SCHEDULE: Public hearing(s) concerning this rulemaking will be scheduled if requested in writing by twenty-five (25) persons, a political subdivision, or an agency, no later than October 16, 2024.

The hearing site(s) will be accessible to persons with disabilities. Requests for accommodation must be made no later than five (5) days prior to the hearing, to the agency address below.

DESCRIPTIVE SUMMARY: The following is a nontechnical explanation of the substance and purpose of the proposed rulemaking:

The Idaho Department of Water Resources (IDWR) initiated this rulemaking in compliance with [Executive Order No. 2020-01, Zero-Based Regulation \(ZBR\)](#) (EO 2020-01), issued by Governor Little on January 16, 2020. Pursuant to EO 2020-01, each rule chapter effective on June 30, 2020, must be reviewed by the promulgating agency over a five-year period. This review is being conducted according to a schedule established by the Division of Financial Management, Office of the Governor (DFM), posted at <https://adminrules.idaho.gov>. This rule chapter was scheduled for review in 2023 and continued into 2024.

With this Notice, IDWR proposes a new chapter of Rules and Minimum Standards for the Construction and Use of Injection Wells (Injection Well Rules). The new chapter is approximately 14.5% shorter than the existing Injection Well Rule chapter following internal agency analysis and external stakeholder negotiation, commentary, and editing. The proposed rule offers a clear set of procedures and minimum standards for the construction and use of waste disposal and injection wells that protect ground water resources and promote public health. Changes include (a) a reorganization of rules to improve ease of use, (b) removal of unnecessary provisions, and (c) the modification of rules to improve clarity such as the addition of Injectate Standards for the Quality of Recycled Water Derived from Municipal or Industrial Wastewater Source. IDWR believes the regulatory measures in the Rule are necessary to protect ground water resources against unreasonable contamination or deterioration of quality to preserve such resources for existing and future diversion to beneficial uses.

The development of the proposed rule text through five publicly-released preliminary rule draft iterations may be viewed at: <https://idwr.idaho.gov/legal-actions/rules/idwr-rulemaking-2023-2024/uic-rules/>. On the same website, IDWR also developed and published rulemaking support documents, which provide IDWR's recommendations on rulemaking, rulemaking analysis, and responses to substantive comments received through the negotiated rulemaking process.

After consideration of public comments received in response to this Proposed Rule, IDWR will present the final rule text during the 2025 Legislative Session.

FEE SUMMARY: The following is a specific description of the fee or charge imposed or increased:

IDAPA 37.03.03 establishes minimum standards and criteria for construction and abandonment of Class V deep and shallow injection wells in the state of Idaho and the injection of fluids to such wells. The rule also establishes the collection of fee(s) to file a notice of application set forth in Idaho Code §§ 42-3905(1) and 42-3905(2).

FISCAL IMPACT: The following is a specific description, if applicable, of any negative fiscal impact on the state General Fund greater than ten thousand dollars (\$10,000) during the fiscal year as a result of this rulemaking: N/A.

NEGOTIATED RULEMAKING: Pursuant to Section 67-5220(1), Idaho Code, negotiated rulemaking was conducted. The Notice of Intent to Promulgate Rules - Negotiated Rulemaking was published in the April 5, 2023 Idaho Administrative Bulletin, [Vol. 23-4, pages 68-69](#).

INCORPORATION BY REFERENCE: Pursuant to Section 67-5229(2)(a), Idaho Code, the following is a brief synopsis of why the materials cited are being incorporated by reference into this rule: N/A

ASSISTANCE ON TECHNICAL QUESTIONS, SUBMISSION OF WRITTEN COMMENTS: For assistance on technical questions concerning the proposed rule, contact Erik Boe at Erik.Boe@idwr.idaho.gov, (208) 287-4800.

Anyone may submit written comments regarding this proposed rulemaking by mail to the address below or by email to rulesinfo@idwr.idaho.gov. All written comments must be directed to the undersigned and must be delivered on or before October 23, 2024.

DATED this 30th day of August, 2024.

Erik Boe, Water Compliance Bureau Chief, Rules Regulation Officer
Idaho Department of Water Resources
322 E. Front Street
PO Box 83720 Boise, ID 83720-0098
Phone: (208) 287-4800

THE FOLLOWING IS THE PROPOSED TEXT OF DOCKET NO. 37-0303-2301
(ZBR Chapter Rewrite)

37.03.03 – RULES AND MINIMUM STANDARDS FOR THE CONSTRUCTION
AND USE OF INJECTION WELLS

000. LEGAL AUTHORITY.

~~This Chapter is adopted under the legal authority of Sections 42-3903A, and 42-3913, 42-3914, and through 42-3915, Idaho Code.~~ (3-18-22)(____)

001. TITLE AND SCOPE.

~~**01. Title.** These rules are titled IDAPA 37.03.03 “Rules and Minimum Standards for the Construction and Use of Injection Wells.”~~ (3-18-22)

~~**02. Scope.** These rules and establish minimum standards are and criteria for construction and use of abandonment of Class V deep and shallow injection wells in the state of Idaho, except Indian lands, and the injection of fluids to such wells. Upon promulgation, these rules apply to all injection wells (see Rule Subsection 035.01). The construction and use of Class I, III, IV, or VI injection wells are prohibited by these rules. Class IV wells are also prohibited by federal law. These rules and minimum standards for construction and use of injection wells apply to all injection wells in the state of Idaho, except in Indian lands. All injection wells shall be permitted and constructed in accordance with the “Well Construction Standards Rules” found in IDAPA 37.03.09 which are authorized under Section 42-238, Idaho Code.~~ (3-18-22)(____)

~~**03. Rule Coverage.** In the event that a portion of these rules is less stringent than the minimum requirements for injection wells as established by Federal regulations (40 CFR Parts 141, 142, 144, 145, and 146), the correlative Federal requirement will be used to regulate the injection well.~~ (3-18-22)(____)

~~**04. Variance of Methods.** The Director may approve the use of a different testing method or technology if it is no less protective of human health and the environment, will not allow the migration of injected fluids into a USDW, meets the intent of the rule, and yields information or data consistent with the original method or~~

~~technology required. A request for review by the Director must be submitted in writing by the applicant, permit holder, or operator and be included with all pertinent information necessary for the Director to evaluate the proposed testing method or technology.~~ (3-18-22)

002. INCORPORATION BY REFERENCE.

~~01. Incorporated Document. IDAPA 37.03.03 adopts and incorporates by reference those ground water quality standards found in Section 200 of IDAPA 58.01.11, "Ground Water Quality Rule," of the Department of Environmental Quality.~~ (3-18-22)

~~02. Document Availability. Copies of the incorporated document may be found at the central office of the Idaho Department of Water Resources, 322 East Front Street, Boise, Idaho, 83720-0098 or online through the department or state websites.~~ (3-18-22)

~~003. -- 009. (RESERVED)~~

010. DEFINITIONS.

~~01. Abandonment. See "permanent decommission."~~ (3-18-22)

~~02. Abandoned Well. See "permanent decommission."~~ (3-18-22)

~~031. Agricultural Runoff Waste. Excess surface water from agricultural fields generated during any agricultural operation, including runoff of irrigation tail water, as well as natural drainage resulting from precipitation, snowmelt, and floodwaters, and is identical to the statutory phrase "irrigation waste water" found in Idaho Code 42-3902.~~ (3-18-22)()

~~042. Applicant. Any owner or operator submitting an application for permit to construct, modify or maintain an injection well to the Director of the Department of Water Resources.~~ (3-18-22)()

~~053. Application. The standard Department forms for applying for a permit, including any additions, revisions or modifications to the forms.~~ (3-18-22)

~~064. Aquifer. Any formation that will yield water to a well in sufficient quantities to make production of water from the formation reasonable for a beneficial use, except when the water in such formation results solely from fluids deposited through an injection well. Any geologic formation(s) that yields water to a well in sufficient quantities to make the production of water from the formation feasible for beneficial use.~~ (3-18-22)()

~~075. Beneficial Use. One (1) or more of the recognized beneficial uses of water including but not limited to, domestic, municipal, irrigation, hydropower generation, industrial, commercial, recreation, aquifer recharge and storage, stockwatering and fish propagation uses, as well as other uses which provide a benefit to the user of the water as determined by the Director. Industrial use as used for purposes of these rules includes, but is not limited to, manufacturing, mining and processing uses of water.~~ (3-18-22)()

~~086. Best Management Practice (BMP). A practice or combination of practices that are more effective than other techniques at preventing or reducing contamination of ground water and surface water by injection well operation.~~ (3-18-22)

~~07. Board. The Idaho Water Resource Board.~~ ()

~~098. Casing. A pipe or tubing of appropriate material, of varying diameter and weight, lowered into a borehole during or after drilling in order to support the sides of the hole and thus prevent the walls from caving, to prevent loss of drilling fluid into porous ground, or to prevent water, gas, or other fluid from entering or leaving the hole. The permanent conduit installed in a well to provide physical stabilization, prevent caving or collapse of the borehole, maintain the well opening and serve as a solid inner barrier to allow for the installation of an annular seal.~~ (3-18-22)()

~~10. Cementing. The operation whereby a cement slurry is pumped into a drilled hole and/or forced behind the casing. (3-18-22)~~

~~109. Cesspool. An injection well that receives sanitary waste without benefit of a treatment system or treatment device such as a septic tank. Cesspools sometimes have open bottom and/or perforated sides. An injection well that receives untreated sanitary waste containing human excreta, and that sometimes has an open bottom and/or perforated sides. (3-18-22)()~~

120. Coliform Bacteria. All of the aerobic and facultative anaerobic, gram-negative, non-spore forming, rod-shaped bacteria that either ferment lactose broth with gas formation within forty-eight (48) hours at thirty-five degrees Celsius (35C), or produce a dark colony with a metallic sheen within twenty-four (24) hours on an Endo-type medium containing lactose. (3-18-22)

131. Confining Bed. A body of impermeable or distinctly less permeable material stratigraphically adjacent to one (1) or more aquifers. (3-18-22)

142. Construct. To create a new injection well or to convert any structure into an injection well. (3-18-22)

153. Contaminant. Any physical, chemical, biological, or radiological substance or matter. (3-18-22)

164. Contamination. The introduction into the natural ground water of any physical, chemical, biological, or radioactive material that may: (3-18-22)

a. Cause a violation of ~~Idaho Ground Water Quality Standards found in IDAPA 58.01.11 “Ground Water Quality Rule” or the federal drinking water quality standards, whichever is more stringent standards found in IDAPA 58.01.11, “Ground Water Quality Rule,” or IDAPA 58.01.08, “Idaho Rules for Public Drinking Water Systems” Section 050, whichever is more stringent;~~ or (3-18-22)()

b. Adversely affect the health of the public; or (3-18-22)

c. Adversely affect a designated or beneficial use of the State’s ground water. Contamination includes the introduction of heated or cooled water into the subsurface that will alter the ground water temperature and render the local ground water less suitable for beneficial use. (3-18-22)

175. Conventional Mine. An open pit or underground excavation for the production of minerals. (3-18-22)

~~186. Decommission (Abandon). To remove a well from operation such that injection through the well is not possible. See “permanent decommission” and “unauthorized decommission”. Any well that has been permanently removed from service and filled or plugged in accordance with these rules so as to meet the intent of these rules. A properly decommissioned well will not: (3-18-22)()~~

~~a. Produce or accept fluids; ()~~

~~b. Serve as a conduit for the movement of contaminants inside or outside the well casing; or ()~~

~~c. Allow the movement of surface or ground water into unsaturated zones, into another aquifer, or between aquifers. ()~~

197. DEQ. The Idaho Department of Environmental Quality. (3-18-22)

2018. Deep Injection Well. An injection well ~~which~~ that is more than eighteen (18) feet in vertical depth below land surface. (3-18-22)()

2419. Department. The Idaho Department of Water Resources. (3-18-22)

- ~~220.~~ **Director.** The Director of the Idaho Department of Water Resources. (3-18-22)
- ~~231.~~ **Disposal Well.** A well used for the disposal of waste into a subsurface stratum. (3-18-22)
- ~~242.~~ **Draft Permit.** A prepared document indicating the Director's tentative decision to issue or deny, modify, revoke and reissue, terminate, or reissue a "permit." Permit conditions, compliance schedules, and monitoring requirements are typically included in a "draft permit". A notice of intent to terminate a permit, and a notice of intent to deny a permit are types of "draft permits." A denial of a request for modification, revocation and reissuance, or termination is not a "draft permit." (3-18-22)
- ~~253.~~ **Drilling Fluid.** ~~Any number of liquid or gaseous fluids and mixtures of fluids and solids (such as solid suspensions, mixtures and emulsions of liquids, gases, and solids) used in operations to drill boreholes into the earth~~ A heavy suspension used in drilling an "injection well," introduced down the drill pipe and through the drill bit. (3-18-22)()
- ~~26.~~ **Drywell.** ~~An injection well completed above the water table so that its bottom and sides are typically dry except when receiving fluids.~~ (3-18-22)
- ~~274.~~ **Endangerment.** ~~Injection of any fluid which exceeds Idaho ground water quality standards, or federal drinking water quality standards, whichever is more stringent, that may result in the presence of any contaminant in ground water which supplies or can reasonably be expected to supply any public or non-public water system, and if the presence of such contaminant may result in such a system not complying with any ground water quality standard or may otherwise adversely affect the health of persons or result in a violation of ground water quality standards that would adversely affect beneficial uses~~ An act that threatens contamination of a USDW aquifer which supplies or can reasonably be expected to supply drinking water to any domestic or public water system where the contamination may result in not complying with Ground Water Quality Standards or otherwise adversely affect human health. (3-18-22)()
- ~~285.~~ **Exempted Aquifer.** An "aquifer" or its portion that meets the criteria in the definition of USDW but which has been recategorized as "other" according to the procedures in IDAPA 58.01.11 "Ground Water Quality Rule". (3-18-22)
- ~~29.~~ **Existing Injection Well.** An "injection well" other than a "new injection well." (3-18-22)
- ~~3026.~~ **Experimental Technology.** A technology which has not been proven feasible under the conditions in which it is being tested. (3-18-22)
- ~~31.~~ **Facility or Activity.** Any UIC "injection well," or another facility or activity that is subject to regulation under the UIC program. (3-18-22)
- ~~32.~~ **Fault.** A surface or zone of rock fracture along which there has been displacement. (3-18-22)
- ~~33.~~ **Flow Rate.** The volume per time unit given to the flow of gases or other fluid substance which emerges from an orifice, pump, turbine or passes along a conduit or channel. (3-18-22)
- ~~3427.~~ **Fluid.** Any material or substance which flows or moves, whether in a semisolid, liquid, sludge, gaseous or any other form or state. (3-18-22)
- ~~35.~~ **Formation.** A body of consolidated or unconsolidated rock characterized by a degree of lithologic homogeneity which is prevailing, but not necessarily, tabular and is mappable on the earth's surface or traceable in the subsurface. (3-18-22)
- ~~36.~~ **Generator.** Any person, by site location, whose act or process produces hazardous waste identified or listed in 40 CFR part 261. (3-18-22)
- ~~3728.~~ **Ground Water.** ~~Any water that occurs beneath the surface of the earth in a saturated formation of rock or soil~~ Water below the land surface in a zone of saturation. (3-18-22)()

~~38~~**29.** **Ground Water Quality Standards.** Standards found in IDAPA 58.01.11, “Ground Water Quality Rule,” Section 200 or IDAPA 58.01.08, “Idaho Rules for Public Drinking Water Systems” Section 050, whichever is more stringent. (3-18-22)()

~~39~~**0.** **Hazardous Waste.** Any substance defined by IDAPA 58.01.05, “Rules and Standards for Hazardous Waste.” (3-18-22)

~~40~~**31.** **Indian Lands.** “Indian Country” as defined in 18 U.S.C. 1151. That section defines Indian Country as: (3-18-22)

a. All land within the limits of any Indian reservation under the jurisdiction of the United States government, notwithstanding the issuance of any patent, and, including rights-of-way running through the reservation; (3-18-22)

b. All dependent Indian communities within the borders of the United States whether within the original or subsequently acquired territory thereof, and whether within or without the limits of a State; and (3-18-22)

c. All Indian allotments, the Indian titles to which have not been extinguished, including rights-of-way running through the same. (3-18-22)

~~41~~**32.** **Individual Subsurface Sewage Disposal System.** For the purpose of these rules, any standard or alternative disposal system ~~which that~~ injects sanitary waste from single family ~~residential domestic~~ septic systems, or non-~~residential domestic~~ septic systems which are used solely for the disposal of sanitary waste and have the capacity to serve fewer than twenty (20) people a day. (3-18-22)()

~~33.~~ **Industrial Wastewater.** All wastewater, treated or untreated, that is not defined as municipal wastewater. ()

~~42~~**34.** **Improved Sinkhole.** A naturally occurring ~~karst depression or other natural~~ crevice found in ~~volcanic terrain and other~~ geologic settings ~~which that~~ have been modified by man for the purpose of directing and emplacing fluids into the subsurface. (3-18-22)()

~~43~~**35.** **Injection.** The subsurface emplacement of fluids through an injection well. (3-18-22)

~~44~~**36.** **Injection Well.** Any feature that is operated to allow injection ~~which that~~ also meets at least one (1) of the following criteria: (3-18-22)()

a. A bored, or driven shaft whose depth is greater than the largest surface dimension; (3-18-22)

b. A dug hole whose depth is greater than the largest surface dimension; (3-18-22)

c. An improved sinkhole; or (3-18-22)

d. A subsurface fluid distribution system. (3-18-22)

~~45.~~ **Injection Zone.** ~~A geological “formation”, or those sections of a formation receiving fluids through an “injection well.”~~ (3-18-22)

~~46.~~ **IWRB.** ~~Idaho Water Resource Board.~~ (3-18-22)

~~47~~**37.** **Large Capacity Cesspools.** Any cesspool used by a multiple dwelling, community, or regional system for the disposal of sanitary wastes (for example: a duplex or an apartment building) or any cesspool used by or intended to be used by twenty (20) or more people per day (for example: a rest stop, campground, restaurant or church). (3-18-22)()

~~48.~~ **Large Capacity Septic System.** ~~Class V wells that are used to inject sanitary waste through a~~

~~septic tank and do not meet the criteria of an individual subsurface sewage disposal system. (3-18-22)~~

~~49. **Maintain.** To allow, either expressly or by implication, an injection well to exist in such condition as to accept or be able to accept fluids. Unless a well has been permanently decommissioned pursuant to the criteria contained in these rules it is considered to be capable of accepting fluids. (3-18-22)~~

~~5038. **Modify.** To alter the construction of an injection well, but does not include cleaning or redrilling operations which neither deepen nor increase the dimensions of the well. (3-18-22)~~

~~5139. **Motor Vehicle Waste Disposal Wells.** Injection wells that receive or have received fluids from vehicle repair or maintenance activities, such as an auto body repair shop, automotive repair shop, new and used car dealership, specialty repair shop (transmission and muffler repair shop), or any facility that does any vehicular repair work. (3-18-22)~~

~~40. **Municipal Wastewater.** Wastewater containing sewage and associated solids, whether treated or untreated. Municipal wastewater, also known as domestic wastewater, may contain industrial wastewater. ()~~

~~52. **New Injection Well.** An "injection well" which began to be used for injection after a UIC program for the State applicable to the well is approved or prescribed. (3-18-22)~~

~~5341. **Open-Loop Heat Pump Return Wells.** Injection wells that receive surface water or ground water that has been passed through a heat exchange system for cooling or heating purposes. (3-18-22)~~

~~54. **Operate.** To allow fluids to enter an injection well by action or inaction of the operator. (3-18-22)~~

~~55. **Operator.** Any individual, group of individuals, partnership, company, corporation, municipality, county, state agency, taxing district, federal agency or other entity that operates or proposes to operate any injection well. (3-18-22)~~

~~5642. **Owner or Operator.** Any individual, group of individuals, partnership, company, corporation, municipality, county, state agency, taxing district, federal agency or other entity owning land on which any injection well exists or is proposed to be constructed. The owner or operator of any facility or activity subject to regulation under these Rules. (3-18-22)()~~

~~57. **Packer.** A device lowered into a well to produce a fluid tight seal. (3-18-22)~~

~~58. **Perched Aquifer.** Ground water separated from an underlying main body of ground water by an unsaturated zone. (3-18-22)~~

~~59. **Permanent Decommission.** The discontinuance of use of an injection well in a method approved by the Director such that the injection well no longer has the capacity to inject fluids and the upward or downward migration of fluid is prevented. This also includes the disposal and proper management of any soil, gravel, sludge, liquids, or other materials removed from or adjacent to the injection well in accordance with all applicable Federal, State, and local regulations and requirements. (3-18-22)~~

~~6043. **Permit.** An authorization, license, or equivalent control document issued by the Department. (3-18-22)~~

~~61. **Person.** Any individual, association, partnership, firm, joint stock company, trust, political subdivision, public or private corporation, state or federal governmental department, agency or instrumentality, or any other legal entity which is recognized by law. (3-18-22)~~

~~6244. **Point of Beneficial Use.** The top or surface of a USDW, directly below an injection well, where water is available for a beneficial use. (3-18-22)~~

~~6345. **Point of Diversion for Beneficial Use.** A location such as Location of a producing well or spring where ground water is taken under control and diverted for a beneficial use. (3-18-22)()~~

~~6446.~~ **Point of Injection.** The last accessible sampling point prior to waste being released into the subsurface environment through an injection well. For example, the point of injection for a Class V septic system might be the distribution box. For a drywell, it is likely to be the well bore itself. (3-18-22)

~~65.~~ **Pressure.** The total load or force per unit area acting on a surface. (3-18-22)

~~6647.~~ **Radioactive Material.** Any material, solid, liquid or gas ~~which that~~ emits radiation spontaneously. Radioactive geologic materials occurring in their natural state are not included. (3-18-22)()

~~6748.~~ **Radioactive Waste.** Any fluid ~~which that~~ contains radioactive material in concentrations ~~which that~~ exceed those established for discharges to water in an unrestricted area by 10 CFR 20.1302.(b)(2)(i) and Table 2 in Appendix B of 10 CFR 20 listed in 10 CFR part 20, appendix B, table II, column 2. (3-18-22)()

~~68.~~ **RCRA.** The Solid Waste Disposal Act as amended by the Resource Conservation and Recovery Act of 1976. (3-18-22)

~~69.~~ **Remediation Project.** Use of an injection well for the removal, treatment or isolation of a contaminant from ground water through actions or the removal or treatment of a contaminant in ground water as approved by the Director. (3-18-22)

~~70.~~ **Residential (Domestic) Activities.** Human activities that generate liquid or solid waste in any public, private, industrial, commercial, municipal, or other facility. (3-18-22)

~~71.~~ **Sanitary Waste.** Any fluid generated through residential (domestic) activities, such as food preparation, cleaning and personal hygiene. This term does not include industrial, municipal, commercial, or other non-residential process fluids. (3-18-22)

~~72.~~ **Schedule of Compliance.** A schedule of remedial measures including an enforceable sequence of actions or operations leading to compliance with the standards. (3-18-22)

~~49.~~ **Recycled Water.** Water treated by a wastewater treatment system and used according to these rules and IDAPA 58.01.17, "Recycled Water Rules." ()

~~7350.~~ **Septic System.** An injection well that is used to inject sanitary waste below the surface. A septic system is typically comprised of a septic tank and subsurface fluid distribution system or disposal system. (3-18-22)

~~7451.~~ **Shallow Injection Well.** An injection well ~~which that~~ is less than or equal to eighteen (18) feet in vertical depth below land surface. (3-18-22)()

~~75.~~ **Site.** The land or water area where any "facility or activity" is physically located or conducted, including adjacent land used in connection with the facility or activity. (3-18-22)

~~76.~~ **State.** The state of Idaho. (3-18-22)

~~77.~~ **Stratum (plural strata).** A single sedimentary bed or layer, regardless of thickness, that consists of generally the same kind of rock material. (3-18-22)

~~7852.~~ **Subsidence.** The lowering of the natural land surface in response to: Earth movements; lowering of fluid pressure; removal of underlying supporting material by mining or solution of solids, either artificially or from natural causes; compaction due to wetting (~~Hydrocompaction~~); oxidation of organic matter in soils; or added load on the land surface. (3-18-22)()

~~7953.~~ **Subsurface Fluid Distribution System.** An assemblage of perforated pipes, drain tiles, or other similar mechanisms intended to distribute fluids below the surface of the ground. (3-18-22)

~~8054.~~ **UIC.** The Underground Injection Control program under Part C of the Safe Drinking Water Act,

including an “approved State program.” (3-18-22)

~~81. **Unauthorized Decommission.** The decommissioning of any injection well that has not received the approval of the Department prior to decommissioning, or was not decommissioned in a method approved by the Director. These wells may have to be properly decommissioned when discovered by the Director to ensure that the well prevents commingling of aquifers or is no longer capable of injection. (3-18-22)~~

~~82. **Underground Injection.** See “injection.” (3-18-22)~~

~~83~~**55. **Underground Source of Drinking Water (USDW).** An aquifer or its portion that: (3-18-22)()**

~~a. Which: Either supplies any public water system, contains a sufficient quantity of ground water to supply a public water system, or currently supplies drinking water for human consumption; and (3-18-22)()~~

~~i. Supplies any public water system; or (3-18-22)~~

~~ii. Contains a sufficient quantity of ground water to supply a public water system; or (3-18-22)~~

~~(1) Currently supplies drinking water for human consumption; or (3-18-22)~~

~~(2) **b.** Contains fewer than ten thousand (10,000) mg/l total dissolved solids; and is not an exempted
aquifer. (3-18-22)()~~

~~**b.** Which is not an exempted aquifer. (3-18-22)~~

~~84~~**56. **Unreasonable Contamination.** Endangerment of a USDW or the health of persons or other beneficial uses by injection. See “endangerment.” (3-18-22)**

~~57. **Wastewater.** Combination of liquid or water and pollutants from activities and processes occurring in dwellings, commercial buildings, industrial plants, institutions, and other establishments, together with any ground water, surface water, and storm water that may be present; liquid or water that is chemically, biologically, physically or rationally identifiable as containing blackwater, gray water, or commercial or industrial pollutants; and sewage. ()~~

~~85. **Water Quality Standards.** Refers to those standards found in Idaho Department of Environmental Quality Rules, IDAPA 58.01.02, “Water Quality Standards” and IDAPA 58.01.11, “Ground Water Quality Rule.” (3-18-22)~~

~~86. **Well.** For the purposes of these rules, “well” means “injection well.” (3-18-22)~~

~~011.—014. (RESERVED)~~

~~015. **VIOLATIONS, FORMAL NOTIFICATION AND ENFORCEMENT.**~~

~~01. **Violations.** It shall be a violation of these rules for any owner or operator to: (3-18-22)~~

~~a. Fail to comply with a permit or authorization, or terms or conditions thereof; (3-18-22)~~

~~b. Fail to comply with applicable standards for water quality; (3-18-22)~~

~~e. Fail to comply with any permit application notification or filing requirement; (3-18-22)~~

~~d. Knowingly make any false statement, representation or certification in any application, report, document or record filed pursuant to these rules, or terms and conditions of an issued permit; (3-18-22)~~

~~e. Falsify, tamper with or knowingly render inaccurate any monitoring device or method required to~~

~~be maintained or utilized by the terms and conditions of an issued permit; (3-18-22)~~

~~f. Fail to respond to any formal notification of a violation when a response is required; or (3-18-22)~~

~~g. Decommission a well in an unauthorized manner. (3-18-22)~~

~~02. **Additional.** It shall be a violation of these rules for any person to construct, operate, maintain, convert, plug, decommission or conduct any other activity in a manner which results or may result in the unauthorized injection of a hazardous waste or of a radioactive waste by an injection well. (3-18-22)~~

~~03. **Formal Notification.** Formal notification of violations may be communicated to the owner or operator with a letter, a notice of violation, a compliance or enforcement order or other appropriate means. (3-18-22)~~

~~04. **Enforcement.** Violation of any of the provisions of the Injection Well Act (Chapter 39, Title 42, Idaho Code) or of any rule, regulation, standard or criteria pertaining to the Injection Well Act may result in the Director initiating an enforcement action as provided under Chapters 17 and 39, Title 42, Idaho Code. (3-18-22)~~

~~016.—019. (RESERVED)~~

020. HEARING BEFORE THE WATER RESOURCE BOARD.

~~01. **General.** All hearings before the IWRB will be conducted in accordance with Chapter 52, Title 67, Idaho Code, at a place convenient to the owner and/or operator. For purposes of such hearings, the IWRB or its designated hearing officer shall have power to administer oaths, examine witnesses, and issue in the name of the said Board subpoenas requiring testimony of witnesses and the production of evidence relevant to any matter in the hearing. Judicial review of the final determination by the IWRB may be secured by the owner by filing a petition for review as prescribed by Chapter 52, Title 67, Idaho Code, in the District Court of the county where the injection well is situated or proposed to be located. The petition for review shall be served upon the Chairman of the IWRB and upon the Attorney General. (3-18-22)~~

~~02. **Hearings on Conditional Permits, Disapproved Applications, or Petitions for Exemption.** Any owner or operator aggrieved by the approval or disapproval of an application, or by conditions imposed upon a permit, or any person aggrieved by the Director's decision on a petition for exemption under Section 025 of these rules, shall be afforded an opportunity for a hearing before the IWRB or its designated hearing officer. Written notice of such grievance shall be transmitted to the Director within thirty (30) days after receipt of notice of such approval, disapproval or conditional approval. Such hearing shall be held for the purpose of determining whether the permit shall be issued, whether the conditions imposed in a permit are reasonable, whether a change in circumstances warrants a change in conditions imposed in a valid permit, or whether the Director's decision on a petition for exemption should not be changed. (3-18-22)~~

~~03. **Hearings on Permit Cancellations.** When the Director has reason to believe the operation of an injection well for which a permit has been issued is interfering with the right of the public to withdraw water for beneficial uses, or is causing unreasonable contamination of a drinking or other ground water source as provided for in Title 42, Chapter 39, Idaho Code, the permit may be canceled by the Director. Prior to the cancellation of such permit there shall be a hearing before the IWRB for the purpose of determining whether or not the permit should be canceled. At such hearing, the Director shall be the complaining party. At least thirty (30) days prior to the hearing, a notice, which shall be in accordance with Chapter 52, Title 67, Idaho Code, shall be sent by certified mail to the owner or operator whose permit is proposed to be canceled. The Board shall affirm, modify, or reject the Director's decision and make its decision in the form of an order to the Director. (3-18-22)~~

~~02411. -- 03419. (RESERVED)~~

03520. CLASSIFICATION OF INJECTION WELLS.

01. Classification of Injection Wells. For the purposes of these rules, injection wells are classified as follows: (3-18-22)

- a.** Class I: (3-18-22)
- i. Wells used by generators of hazardous waste or owners or operators of hazardous waste management facilities to inject hazardous waste beneath the lowermost formation containing, within one-quarter (1/4) mile of the well bore, an underground source of drinking water. (3-18-22)
- ii. Other industrial and municipal disposal wells which inject fluids beneath the lowermost formation containing, within one-quarter (1/4) mile of the well bore, an underground source of drinking water. (3-18-22)
- iii. Radioactive waste disposal wells which inject fluids below the lowermost formation containing an underground source of drinking water within one-quarter (1/4) mile of the well bore. (3-18-22)
- b.** Class II. Wells used to inject fluids: (3-18-22)
- i. Which are brought to the surface in connection with natural gas storage operations, or conventional oil or natural gas production and may be commingled with waste waters from gas plants, dehydration stations, or compressor stations which are an integral part of production operations, unless those waters are classified as a hazardous waste at the time of injection. (3-18-22)
- ii. For enhanced recovery of oil or natural gas; and (3-18-22)
- iii. For storage of hydrocarbons which are liquid at standard temperature and pressure. (3-18-22)
- c.** Class III. Wells used to inject fluids for extraction of minerals including: (3-18-22)
- i. Mining of sulfur by the Frasch process; (3-18-22)
- ii. In situ production of uranium or other metals; this category includes only in-situ production from ore bodies which have not been conventionally mined. Solution mining of conventional mines such as stopes leaching is included in Class V. (3-18-22)
- iii. Solution mining of salts or potash. (3-18-22)
- d.** Class IV: (3-18-22)
- i. Wells used by generators of hazardous waste or of radioactive waste, by owners or operators of hazardous waste management facilities, or by owners or operators of radioactive waste disposal sites to dispose of hazardous waste or radioactive waste into or above a formation which within one-quarter (1/4) mile of the well contains an underground source of drinking water. (3-18-22)()
- ~~ii. Wells used by generators of hazardous waste or of radioactive waste, by owners or operators of hazardous waste management facilities, or by owners or operators of radioactive waste disposal sites to dispose of hazardous waste or radioactive waste above a formation which within one-quarter (1/4) mile of the well contains an underground source of drinking water. (3-18-22)~~
- iii. Wells used by generators of hazardous waste or owners or operators of hazardous waste management facilities to dispose of hazardous waste, which cannot be classified under Subparagraphs ~~035.01.a.i.~~ 020.01.a.i or ~~035.01.d.i.~~ 020.01.d.i or ~~035.01.d.ii.~~ of this rule (e.g., wells used to dispose of hazardous waste into or above a formation which contains an aquifer which has been exempted pursuant to Section 025 of these rules). (3-18-22)()
- e.** Class V -- All injection wells not included in Classes I, II, III, IV, or VI. (3-18-22)
- f.** Class VI. (3-18-22)
- i. Wells that are not experimental in nature that are used for geologic sequestration of carbon dioxide beneath the lowermost formation containing a USDW; or (3-18-22)

ii. Wells used for geologic sequestration of carbon dioxide that have been granted a waiver of the injection depth requirements pursuant to requirements at 40 CFR Section 146.95; or (3-18-22)

iii. Wells used for geologic sequestration of carbon dioxide that have received an expansion to the areal extent of an existing Class II enhanced oil recovery or enhanced gas recovery aquifer exemption pursuant to Section 025 of these rules. (3-18-22)

- 02. Subclassification.** Class V wells are subclassified as follows: (3-18-22)
- a. 5A5-Electric Power Generation. (3-18-22)
 - b. 5A6-Geothermal Heat. (3-18-22)
 - c. 5A7-Heat Pump Return. (3-18-22)
 - d. 5A8-Aquaculture Return Flow. (3-18-22)
 - e. 5A19-Cooling Water Return. (3-18-22)
 - f. 5B22-Saline Water Intrusion Barrier. (3-18-22)
 - g. 5D2-Storm Runoff. (3-18-22)
 - h. 5D3-Improved Sinkholes. (3-18-22)
 - i. 5D4-Industrial Storm Runoff. (3-18-22)
 - j. 5F1-Agricultural Runoff Waste¹. (~~3-18-22~~)()
 - k. 5G30-Special Drainage Water. (3-18-22)
 - l. 5N24¹-Radioactive Waste Disposal¹. (~~3-18-22~~)()
 - m. 5R21-Aquifer Recharge. (3-18-22)
 - n. 5S23-Subsidence Control. (3-18-22)
 - o. 5W9-Untreated Sewage¹. (~~3-18-22~~)()
 - p. 5W10- Large Capacity Cesspools². (~~3-18-22~~)()
 - q. 5W11-Septic Systems (General). (3-18-22)
 - r. 5W12-Waste Water Treatment Plant Effluent. (3-18-22)
 - s. 5W20-Industrial Process Water. (3-18-22)
 - t. 5W31-Septic Systems (Well Disposal). (3-18-22)
 - u. 5W32-Septic System (Drainfield). (3-18-22)
 - v. 5X13-Mine Tailings Backfill. (3-18-22)
 - w. 5X14-Solution Mining. (3-18-22)
 - x. 5X15-In-Situ Fossil Fuel Recovery. (3-18-22)

- y. 5X16-Spent Brine Return Flow. (3-18-22)
- z. 5X25-Experimental Technology. (3-18-22)
- aa. 5X26-Aquifer Remediation. (3-18-22)
- bb. 5X27-Other Wells. (3-18-22)
- cc. 5X28¹-Motor Vehicle Waste Disposal Wells². ~~(3-18-22)~~()
- dd. 5X29-Abandoned Water Wells. (3-18-22)

¹The construction of wells in this subclass is currently prohibited in Idaho.

²The construction and operation of wells in these subclasses is currently ~~illegal~~ prohibited in Idaho.

~~03621~~. -- ~~03924~~. (RESERVED)

~~04025~~. AUTHORIZATIONS, PROHIBITIONS AND EXEMPTIONS.

01. Authorizations. Construction and use of Class V deep injection wells may be authorized by permit as approved by the Director in accordance with these rules and the “Well Construction Standards Rules” found in IDAPA 37.03.09 which are authorized under Section 42-238, Idaho Code. ~~(3-18-22)~~()

02. Prohibitions. (3-18-22)

a. These rules prohibit the permitting, construction, or use of any Class I, III, IV, or VI injection well. ~~(3-18-22)~~()

b. No owner or operator shall construct, operate, maintain, convert, plug, abandon, or conduct any other injection activity in a manner that allows or causes the movement of fluid containing any contaminant into underground sources of drinking water, if the presence of that contaminant may cause a violation of any primary or secondary drinking water regulation, under IDAPA 58.01.11, “Ground Water Quality Rule,” Section 200 or may otherwise adversely affect the health of persons. The applicant for a permit ~~shall have~~ has the burden of showing that the ~~requirements of Paragraph 040.02.e. are met~~ injection of any fluid does not present an imminent and substantial endangerment to the health of persons. ~~(3-18-22)~~()

c. Notwithstanding any other provision of this section, the Director may take emergency action upon receipt of information that a contaminant which is present in or likely to enter a public water system or ~~underground source of drinking a USDW~~ water may present an imminent and substantial endangerment to the health of persons. ~~(3-18-22)~~()

d. ~~Construction of~~ Large capacity cesspools, motor vehicle waste disposal wells, radioactive waste disposal wells, and untreated sewage disposal wells ~~is~~ are prohibited. ~~Construction and use of other Class V shallow injection wells are authorized by these rules without permit provided that:~~ All prohibited wells described in this section must be decommissioned in accordance with these rules. ~~(3-18-22)~~()

~~i. Required inventory information is submitted to the Director pursuant to Subsection 070.01 of this rule.~~ ~~(3-18-22)~~

~~ii. Use of the shallow injection well shall not result in unreasonable contamination of a USDW or cause a violation of surface or ground water quality standards that would affect a beneficial use.~~ ~~(3-18-22)~~

e. Construction of new Subclass 5F1 - Agricultural Runoff Waste injection wells is prohibited. ()

~~ef. Class IV injection wells used to inject~~ These rules do not prohibit the injection of contaminated ground water ~~that has been treated and is being reinjected~~ into the same formation from which it was drawn ~~are not~~

~~prohibited by these rules~~ provided the contaminated ground water is treated and if such injection is approved by EPA, ~~or Idaho~~, pursuant to provisions for cleanup of releases under the Comprehensive Environmental Response, Compensation, and Liability Act of 1980 ~~(CERCLA)~~, 42 U.S.C. 9601–9657, or pursuant to requirements and provisions under the Resource Conservation and Recovery Act ~~(RCRA)~~, 42 U.S.C. 6901 through 6987. (3-18-22)()

~~f. All large capacity cesspools must be properly decommissioned by January 1, 2005. A cease and desist order may be issued to the owner or the operator when a large capacity cesspool is found to be a threat to the ground water resources as described in Paragraph 070.01.e.~~ (3-18-22)

~~g. All motor vehicle waste disposal wells must be properly decommissioned by January 1, 2005. A cease and desist order may be issued to the owner or the operator when a motor vehicle waste disposal well is found to be a threat to the ground water resources as described in Paragraph 070.01.e.~~ (3-18-22)

~~h. The Construction, operation or maintenance of any non-experimental Class V geologic sequestration well is prohibited.~~ (3-18-22)

~~i. Owners or operators of shallow injection wells are prohibited from injecting into the well upon failure to submit inventory information in a timely manner pursuant to Paragraph 070.01.a. of these rules.~~ (3-18-22)

03. Exemptions. (3-18-22)

a. Construction and use of Class V shallow injection wells are authorized by these rules without permit provided that: ()

i. Required inventory information is submitted to the Director in accordance with these rules. ()

ii. Use of a shallow injection well shall not result in injection of recycled water derived from municipal or industrial sources. ()

iii. Use of a shallow injection well shall not result in unreasonable contamination of a USDW or cause a violation of Ground Water Quality Standards that would affect a beneficial use. ()

~~ab. The UIC inventory and fee requirements of these rules do not apply to~~ i Individual subsurface sewage disposal system wells. ~~These systems are, however,~~ are exempt from these Rules but subject to the permitting and fee requirements of IDAPA 58.01.03 “Individual/Subsurface Sewage Disposal Rules,” Title 39, Chapter 1 and Title 39, Chapter 36, Idaho Code. (3-18-22)()

~~b. State or local government entities are exempt from the permit requirements of these rules for wells associated with highway and street construction and maintenance projects, but shall submit shallow injection well inventory information for said wells and shall comply with all other requirements of these rules.~~ (3-18-22)

ec. Mine tailings backfill (5X13) wells are authorized by rule as part of mining operations. They are therefore exempt from ~~the ground water quality standards and~~ permitting requirements of these rules provided that their use is limited to the injection of mine tailings only. The use of any 5X13 well(s) shall not result in ground water quality standards at points of diversion for beneficial use ~~being exceeded that exceed~~ or otherwise affect a beneficial use. Should ground water quality standards be exceeded or beneficial uses be affected, the Director may order the wells to be put under the permit requirements of these rules, or the wells may be required to be remediated or closed. As a condition of their use, the Director may require the construction and sampling of monitoring wells by the owner/operator. 5X13 wells are subject to the inventory requirements ~~of Subsection 070.01~~ described in these Rules. (3-18-22)()

04. Variance of Methods. The Director may approve the use of a different testing method or technology if it is no less protective of human health and the environment, will not allow the migration of injected fluids into a USDW, meets the intent of the rule, and yields information or data consistent with the original method or technology required. A request for review by the Director must be submitted in writing by the applicant, permit holder, or operator and be included with all pertinent information necessary for the Director to evaluate the proposed

testing method or technology. ()

~~0426.~~ -- ~~06929.~~ (RESERVED)

030. CLASS V SHALLOW INJECTION WELL REQUIREMENTS.

01. Authorization. All owners or operators of shallow Class V injection wells, including improved sinkholes used for aquifer recharge, that dispose of nonhazardous and nonradioactive wastes are required to submit a Shallow Injection Well Inventory Form to the Department no later than thirty (30) days prior to commencement of construction for each new well or no later than thirty (30) days after the discovery of an existing injection well that has not previously been inventoried with the Department. ()

02. Inventory Fees. For shallow injection wells constructed after July 1, 1997, the Shallow Injection Well Inventory Form shall be accompanied by a fee as specified in Section 42-3905(2), Idaho Code, payable to the Department of Water Resources. State or local government entities are exempt from filing fees for shallow injection wells associated with highway and street construction and maintenance. ()

03. Decommission. Owners or operators of shallow injection wells must notify the Director not less than thirty (30) days prior to permanent decommissioning of any shallow injection well. Decommissioning must be accomplished in accordance with procedures approved by the Director. ()

04. Inter-Agency Cooperation. The Department may seek the assistance of other state or local government agencies or entities, including cities, counties, health districts, and highway districts to inventory, monitor, and inspect shallow injection wells. Assistance is to be negotiated through a memorandum of understanding between the Department and the state or local entity subject to the Director's approval. ()

05. Cessation of Injection Well Activity. The Director will require immediate cessation of any Class V shallow injection well activity that causes or may cause unreasonable contamination of a USDW or a violation of ground water quality standards. ()

~~031.~~ -- ~~034.~~ (RESERVED)

035. CLASS V INJECTION WELL REQUIREMENTS.

01. Permit Required for Class V Deep Injection Wells. No person shall construct, modify, maintain, or use a Class V deep injection well unless a permit has been issued by the Director. An application for permit must be completed and filed with the director on a form approved by the department accompanied by a filing fee as specified in Section 42-3905(1), Idaho Code. Applications proposing to inject recycled water derived from municipal or industrial wastewater sources must also adhere to all applicable IDEQ rules and permitting requirements. ()

02. Permit Requirements for Class V Shallow Injection Wells. No person shall construct, modify, maintain, or use a Class V shallow injection well to inject recycled water derived from municipal or industrial wastewater sources unless a permit has been issued by the Director. An application for permit must be completed and filed with the director on a form approved by the department accompanied by a filing fee as specified in Section 42-3905(1), Idaho Code. An application for permit may be required for the construction, modification, or use of all other shallow injection wells if the Director determines that the injection could result in unreasonable contamination of a USDW or cause a violation of Ground Water Quality Standards that would affect a beneficial use. Applications proposing to inject recycled water derived from municipal or industrial wastewater sources must also adhere to all applicable IDEQ rules and permitting requirements. ()

03. Application Information Required. An applicant must submit the following information to the Director for all injection wells to be authorized by permit, unless the Director determines that it is not needed in whole or in part, and issues a written waiver to the applicant: ()

a. Facility name and location; ()

b. Name, address and phone number of the well operator; ()

- c. Class, subclass and function of the injection well (see Section 020); ()
 - d. Latitude/longitude or legal description of the well location to the nearest ten (10) acre tract; ()
 - e. Ownership of the well; ()
 - f. County in which the injection well is located; ()
 - g. Construction information for the well; ()
 - h. Describe the quality, composition, and quantity of the injected fluids; ()
 - i. Status of the well; ()
 - j. A topographic map or aerial photograph extending one (1) mile beyond property boundaries,
depicting: ()
 - (1) Location of the injection well and associated facilities described in the application; ()
 - (2) Locations of other injection wells; ()
 - (3) Approximate drainage area, if applicable; ()
 - (4) Hazardous waste facilities, if applicable; ()
 - (5) All wells used to withdraw drinking water; ()
 - (6) All other wells, springs and surface waters. ()
 - i. Distance and direction to nearest domestic well; ()
 - ii. Depth to ground water; and ()
 - iii. Alternative methods of waste disposal. ()
- 04. Additional Information.** The Director may require an applicant to submit additional information to demonstrate that the proposed or existing injection well will not endanger a USDW. The Director will not complete the processing of an application for which additional information has been requested until such time as the additional information is supplied. The Director may return any incomplete application and will not process such application until such time as the application is received in complete form. Additional information may include, but is not limited to the following items: ()
- a. A topographic map showing locations of the following within a two (2) mile radius of the injection well; ()
 - (1) All wells producing water; ()
 - (2) All exploratory and test wells; ()
 - (3) All other injection wells; ()
 - (4) Surface waters (including man-made impoundments, canals and ditches); ()
 - (5) Mines and quarries; ()

- (6) Residences: ()
- (7) Roads: ()
- (8) Bedrock outcrops; and ()
- (9) Faults and fractures. ()
- b.** Additional maps or aerial photographs of suitable scale to accurately depict the following: ()
 - (1) Location and surface elevation of the injection well described in this permit; ()
 - (2) Location and identification of all facilities within the property boundaries; ()
 - (3) Locations of all wells penetrating the proposed injection zone or within a one-quarter (1/4) mile radius of the injection well; ()
 - (4) Maps and cross sections depicting all underground sources of drinking water to include vertical and lateral limits within a one-quarter (1/4) mile radius of the injection well, their position relative to the injection zone and the direction of water movement; local geologic structures; regional geologic setting. ()
- c.** A comprehensive report of the following information: ()
 - (1) A tabulation of all wells penetrating the proposed injection zone, listing owner, lease holder and operator; well identification (permit) number; size, weight, depth and cementing data for all strings of casing; ()
 - (2) Description of the quality, composition, and quantity of fluids to be injected; ()
 - (3) Description of geologic, hydrogeologic, and geochemical conditions present in the injection zone and confining beds; methods for determining geochemical conditions must be approved by the Director; ()
 - (4) Engineering data for the proposed injection well; ()
 - (5) Proposed operating pressure; ()
 - (6) A detailed evaluation of alternative disposal practices; ()
 - (7) A plan of corrective action for wells penetrating the zone of injection, but not properly sealed or decommissioned; and ()
 - (8) Contingency plans to cope with all shut-ins or well failures to prevent the migration of unacceptable fluids into underground sources of drinking waters. ()
- d.** Name, address and phone number of person(s) or firm(s) supplying the technical information and/or designing the injection well; ()
- e.** Proof that the applicant is financially responsible, through a performance bond or other appropriate means, to decommission the injection well in a manner approved by the Director. ()

036. -- 049. (RESERVED)

050. CLASS V INJECTION WELL REQUIREMENTS – APPLICATION PROCESSING.

01. Draft Permit Preparation. After all application information is received and evaluated, the Director will prepare a draft permit or denial, which will include the application for permit, permit conditions or reasons for denial, and any compliance schedules or monitoring requirements. In preparing the draft permit or denial,

the Director must consider the following factors: ()

- a. The availability of economic and practical alternative means of disposal; ()
- b. The application of best management practices to the facilities and/or area draining into the well; ()
- c. The availability of economical, practical means of treating or otherwise reducing the amount of contaminants in the injected fluids; ()
- d. The quality of the receiving ground water, its category, its present and future beneficial uses or interconnected surface water; ()
- e. The location of the injection well with respect to drinking water supply wells; and ()
- f. Compliance with Ground Water Quality Standards. ()
- g. The benefit to the State of Idaho. ()

02. Public Notice. The Director will provide public notice of any draft permit to construct, maintain or modify a Class V injection well by means of a legal notice in a newspaper of general circulation in the county in which the well is located. The Director may give additional notice as necessary to adequately inform the interested public and governmental agencies. There shall be a period of at least thirty (30) days following publication for any interested person to submit written comments. ()

03. Review by the Directors of Other State Agencies. The Directors of other state agencies, as determined by the Director, shall be given an opportunity to review and comment on draft permits. Comments must be submitted to the Director within thirty (30) days of public notice. ()

04. Open-Loop Heat Pump Return Wells (Subclass 5A7). The Director may waive the draft permit and recurring permit cycle requirements of these rules for any application proposing use of an open-loop heat pump return well greater than eighteen (18) feet in depth solely for disposal of heat pump water at a rate not exceeding fifty (50) gpm. ()

05. Fact-Finding Hearings. At the Director's discretion, or upon motion of any interested individual, the Director may elect to hold a fact-finding hearing. Said hearing will be held at a location in the geographical area of the injection well. Notice of said hearing will be provided at least thirty (30) days in advance of the hearing by regular mail to the applicant and to the person or persons requesting the hearing. Public notice of the fact-finding hearing shall be made in a newspaper of general circulation in the county where the injection well is located. ()

06. Draft Permit Final Review and Consideration. The Director will consider the following factors when taking final action on draft permits: ()

- a. The potential for unreasonable contamination or deterioration of ground water quality; ()
- b. The likelihood and consequences of the injection well system failing; ()
- c. The long-term effects of such disposal or storage; ()
- d. The recommendations and related justifications of the Directors of other state agencies and the public; ()
- e. The potential for violation of Ground Water Quality Standards at the point of injection or the point of beneficial use; and ()
- f. Compliance with the Idaho Ground Water Quality Plan. ()

07. Issuance of Permit. After considering the draft permit for construction, modification, or maintenance, and all matters relating thereto, the Director shall issue a permit if the standards and criteria be met and USDW's will not be unreasonably affected. If the Director finds that the standards and criteria cannot be met or that ground water sources cannot be protected from unreasonable contamination at all times, the draft permit may be denied or a permit may be issued with conditions designed to protect ground water sources. The Director's decision will be in writing and a copy mailed by regular mail to the applicant and to all persons who commented in writing on the draft permit or appeared at a hearing held to consider the draft permit. ()

08. Permit Conditions and Requirements. Any permit issued by the Director shall contain conditions to protect ground water sources from waste, contamination, or deterioration of Ground Water Quality Standards. In addition to specific construction, operation, maintenance, monitoring, and reporting requirements that the Director finds necessary, each permit shall be subject to the standard conditions and requirements of this rule. ()

09. Permit Decision Notice. The Director's decision shall be in writing and a copy shall be mailed by regular mail to the applicant and all persons who commented in writing on the draft permit or appeared at a hearing held to consider the draft permit. ()

051. (RESERVED)

052. CLASS V INJECTION WELL CONSTRUCTION AND OPERATION REQUIREMENTS.

01. Construction Requirements. The following requirements apply to all Class V injection wells authorized by permit unless noted differently: ()

a. Deep injection wells shall be constructed by an Idaho licensed well driller to conform with the current Well Construction Standards (IDAPA 37.03.09), the conditions of the well construction permit, and the conditions of the injection well permit issued pursuant to these rules, except that a driller's license is not required for the construction of a driven mine shaft or a dug hole. ()

b. Well drillers or other persons involved with the construction of any injection well shall not commence construction of the injection well until a certified copy of the approved injection well permit is obtained from the Director. ()

c. Injection wells shall be constructed in accordance with the conditions of the permit. Rule-authorized shallow injection wells shall be constructed as shown or described in the inventory submittal. ()

d. Injection wells shall be constructed to prevent the entrance of any fluids other than specified in the permit. ()

e. Deep injection wells shall be constructed to prevent waste of artesian fluids or movement of fluids from one aquifer into another. ()

f. When construction or modification of an injection well has been completed, the owner or operator shall inform the Director of completion on a form provided by the Department. ()

g. A sampling port shall be provided for deep injection well systems if the system is enclosed. ()

h. All new injection wells constructed into alluvial formations shall have a minimum ten (10) foot separation from the bottom of the well and seasonal high ground water. ()

02. Operational Conditions and Requirements. The following requirements apply to all Class V injection wells authorized by permit unless noted differently: ()

a. The injection well shall not be used until the construction, operation and maintenance requirements of the permit are met and provisions are made for any required inspection, monitoring and record keeping. ()

b. For both permitted injection wells and rule-authorized shallow injection wells, injection of any

contaminant at concentrations exceeding the standards described in Section 055 of this rule into a present or future drinking or other ground water source that may cause a health hazard or adversely affect a designated and protected use is prohibited. ()

c. The injection well owner or operator shall develop approved procedures to detect constructional or operational failure in a timely fashion and shall have contingency plans to cope with the well failure. ()

d. Authorized representatives of the Department shall be allowed to enter, inspect and/or sample: ()

(i.) The injection well and related facilities; ()

(ii.) The owner or operator's records of the injection operation; ()

(iii.) Monitoring instrumentation associated with the injection operation; and ()

(iv.) The injected fluids. ()

e. The injection facilities shall be operated and maintained to achieve compliance with all terms and conditions of this permit. ()

f. Proper operation and maintenance includes effective performance, adequate funding, operator staffing and training, and adequate laboratory and process controls, including appropriate quality assurance procedures; ()

g. If compliance cannot be met, the owner shall take corrective action as determined by the Director or terminate injection. ()

h. The owner shall mitigate any adverse effects resulting from non-compliance with the terms and conditions of the permit. ()

i. If the injection well was constructed prior to issuance of the permit, the well shall be brought into compliance with the terms and conditions of the permit in accordance with the schedule of compliance issued by the Director. ()

j. The permit shall not convey any property rights. ()

03. Conditions of Permanent Decommissioning. The following requirements apply to all Class V injection wells authorized by permit and rule authorized shallow injection wells, unless noted differently: ()

a. Notice of intent to permanently decommission a well shall be submitted to the Director not less than thirty (30) days prior to commencement of the decommissioning activity. ()

b. The method of permanent decommissioning for all injection wells shall be approved by the Director prior to commencement of the decommissioning activity. ()

c. Notice of completion of permanent decommission shall be submitted to the Director within thirty (30) days of completion. ()

d. All deep injection wells that are to be permanently decommissioned shall be plugged in accordance with current Well Construction Standards. ()

e. Following permanent cessation of use, or where an injection well is not completed, the Director shall be notified. Decommissioning procedures or other action, as prescribed by the Director, shall be conducted. ()

f. The injection well owner or operator has the responsibility to ensure that the injection operation is

decommissioned as prescribed. ()

04. Duration of Approved Permits. The length of time that a permit may be in effect for Class V wells authorized by permit shall not exceed ten (10) years. ()

053 - 054. (RESERVED)

055. STANDARDS FOR THE QUALITY OF FLUIDS INJECTED INTO CLASS V WELLS.

01. General. Injected fluids shall meet Ground Water Quality Standards for physical, biological, chemical, and radiological contaminants, and if ground water produced from adjacent points of diversion for beneficial use meets the Ground Water Quality Standards as defined in these rules, then that aquifer will be protected from unreasonable contamination and will be preserved for diversion to beneficial uses. The Director may, however, when it is deemed necessary, require specific injection wells to be constructed and operated in compliance with additional requirements, such as best management practices (BMPs), so as to protect the ground water resource from deterioration and preserve it for diversion to beneficial use. ()

02. Waivers. A waiver of one (1) or more standards may be granted by the Director if it can be demonstrated by the applicant that the contaminants in injected fluid will not endanger a ground water source for any present or future beneficial use. ()

03. Chemical and Radiological Contaminants in Injected Fluids. The following limits shall not be exceeded in injected fluids from a well when such fluids will or are likely to reach a USDW: ()

a. The concentration of each chemical contaminant in the injected fluids shall not exceed the concentration of each applicable contaminant in the receiving water or the ground water quality standard, whichever is less stringent; and ()

b. Radiological levels of the injected fluids shall not exceed those levels specified by the Ground Water Quality Standards. ()

04. Biological contaminants. The following restrictions apply to injected fluids with biological contaminants included in the ground water quality standard. ()

a. Contamination of ground water produced at any point of diversion for beneficial use by injected fluids containing coliform bacteria in concentrations greater than the current ground water quality standard is prohibited; ()

b. Construction of shallow and deep injection wells, as specified by the Director, that are likely to exceed the current ground water quality standard for coliform bacteria at the point of diversion for beneficial use is prohibited; and ()

c. The Director may require the use of best management practices (BMPs) to reduce the potential concentration of coliform bacteria in the injected fluids; ()

d. The Director may require the use of water treatment technology, including ozonation and chlorination devices, sand filters, and settling pond specifications to reduce the potential concentration of coliform bacteria in injected fluids; ()

e. Ground water produced from points of diversion for beneficial use within the distances identified in Table 1. that inject fluids containing coliform bacteria in concentrations greater than the current ground water quality standard shall be subject to monitoring for bacteria by the owner/operator of the injection well. A waiver of the monitoring requirement may be granted by the Director when it can be demonstrated that injection will not result in unreasonable contamination of ground water produced from these adjacent points; ()

f. At no time shall any untreated fluid containing fecal contaminants of human origin be injected into any Class V injection well authorized under these rules. Subsurface fluid distribution systems that apply or distribute

recycled water to the root-zone and regulated by IDEQ are exempt from this rule. ()

05. Physical, Visual, and Olfactory Characteristics. The following restrictions apply to physical, visual, and olfactory characteristics of injected fluids. The temperature, color, odor, conductivity, turbidity, pH, or other characteristics of the injected fluid may not result in the receiving ground water becoming less suitable for diversion to beneficial uses, as determined by the Director. ()

06. Injectate Standards for the Quality of Recycled Water Derived from a Municipal or Industrial Wastewater Source. ()

a. Shallow Injection Wells. The concentration of contaminants in recycled water derived from municipal or industrial wastewater sources must prevent contamination and comply with established Ground Water Quality Standards and all other applicable IDEQ rules and permitting requirements prior to injecting into a shallow injection well. ()

b. Deep Injection Wells. The concentration of contaminants in recycled water derived from municipal or industrial wastewater sources must prevent contamination and comply with established Ground Water Quality Standards and all other applicable IDEQ rules and permitting requirements prior to injecting into a deep injection well. Additionally, injected fluids must not result in the endangerment of a USDW. Recycled water quality requirements shall be determined by the Department in coordination with IDEQ during the permitting process. The background concentration of any applicable contaminant shall be determined by a statistical analysis consisting of a type and method approved by the Department. ()

07. Standards for the Quality of Fluids Injected to Subclass 5A7 Wells (Open-Loop Heat Pump Return). ()

a. The quality of fluids injected to a Subclass 5A7 injection well shall comply with Ground Water Quality Standards or shall be equal to the quality of the ground water source passed through a heat exchange system, whichever is less stringent. ()

b. If the quality of the ground water source does not meet Ground Water Quality Standards, the injected fluids must be returned to the formation from which they were drawn. ()

c. The temperature of the injected fluids shall not impair the designated beneficial uses of the receiving ground water. ()

056. (RESERVED)

057. CRITERIA FOR LOCATION AND USE OF CLASS V WELLS REQUIRING PERMITS.

01. General: A Class V injection well requiring a permit may be required to be located a minimum distance, as determined from Table 1, from any point of diversion for beneficial use that could be harmed by bacterial contaminants. The minimum distance shown in Table 1 is also referred to as the zone of influence. This requirement is not applicable to wells injecting fluids of quality that meet adopted Ground Water Quality Standards. In addition, the Director may require a Class V injection well to be located a distance from a point of diversion for beneficial use to minimize or prevent ground water contamination resulting from unauthorized or accidental injection, as determined by the Director. ()

a. The location requirements in Table 1 may be waived when the applicant can demonstrate that any springs or wells within the minimum distance as determined from Table 1 will not be contaminated by the applicant's injection well. The applicant may be required to monitor production wells or springs within the minimum distance as determined in Table 1 to demonstrate that they are not being contaminated. ()

Determined Radii of the Zone of Influence Based on Maximum Average Weekly Injection Rates (cfs) of Class V Injection Wells *	
Injection (cfs)	Radius (ft)
0 - 0.20	800
0.21 - 0.60	1,400
0.61 - 1.00	1,800
1.01 - 2.00	2,500
2.01 - 3.00	3,000
3.01 - 4.00	3,500
4.01 - 5.00	4,000
Greater than 5.00	As determined by the Director

* Injection rates shall be based on the average volume of fluids injected into the well during the week of greatest injection in an average water year. ()

b. The Director may reduce separation distance requirements if the quality of injected fluids are improved through additional treatment or BMPs. ()

c. Heat pump return wells (sub-class 5A7) are exempt from the separation distance requirement of this section. ()

058. MONITORING, RECORD KEEPING, AND REPORTING REQUIREMENTS.

The Director may require monitoring, record keeping, and reporting by any owner or operator if the Director finds that the well may adversely affect a ground water source or is injecting a contaminant that could have an unacceptable effect upon the quality of the ground waters of the state. ()

01. Monitoring. The Director may require, as conditions of the permit, the installation, use, and maintenance of monitoring equipment or methods including, but not limited to, the following: ()

a. Monitoring of injection pressures and pressures in the annular space between casings; ()

b. Flow rate and volumes; ()

c. Analysis of quality of the injected fluids for contaminants that are subject to limitation or reduction under the conditions of the permit; or other contaminants which the Director has reason to believe are in the injected fluids; ()

d. Monitoring of ground water through special monitoring wells or existing points of diversion for beneficial use in the zone of influence as determined by the Director; ()

e. A demonstration of the integrity of the casing, tubing, or seal of the injection well. ()

f. The frequency of required monitoring shall be specified in the permit when issued, except that the Director at any time may, in writing, require additional monitoring and reporting. ()

g. All monitoring tests and analysis required by permit conditions shall be performed in a state certified laboratory or other laboratory approved by the Director. ()

h. Any field instrumentation used to gather data, when specified as a condition of the permit, shall be required by the Director to be tested and maintained in such a manner as to ensure the accuracy of the data. ()

i. All samples and measurements taken for the purpose of monitoring shall be representative of the monitoring activity and fluids injected. ()

02. Record Keeping. The permittee shall maintain records of all monitoring activities to include: ()

a. Date, time, and exact place of sampling; ()

b. Person or firm performing analysis; ()

c. Date of analysis, analytical methods used and results of analysis; ()

d. Calibration and maintenance of all monitoring instruments; and ()

e. All original tapes, strip charts or other data from continuous or automated monitoring instruments. ()

03. Reporting. Monitoring results obtained by the permittee pursuant to the monitoring requirements prescribed by the Director shall be reported to the Director as required by permit conditions. ()

a. The Director shall be notified in writing by the permittee within five (5) days after the discovery of a violation of the terms and conditions of the permit. If the injection activity endangers human health or a public or domestic water supply, use of the injection well shall be immediately discontinued, and the owner or operator shall immediately notify the Director. Notification shall contain the following information: ()

i. A description of the violation and its cause; ()

ii. The duration of the violation, including dates and times; if not corrected or use of the well discontinued, the anticipated time of correction; and ()

iii. Steps being taken to reduce, eliminate and prevent recurrence of the injection. ()

b. Where the owner or operator becomes aware of failure to submit any relevant facts in any permit application or report to the Director, that person shall promptly submit such facts or information. ()

c. The permittee shall furnish the Director, within a time specified by the Director, any information which the Director may request to determine compliance with the permit. ()

d. The Director shall be notified in writing of planned physical alterations or additions to any facility related to the permitted injection well operation. ()

e. Additional information to be reported to the Director in writing shall include: ()

i. Transfer of ownership; ()

ii. Any change in operational status not previously reported; ()

iii. Any anticipated noncompliance; and ()

iv. Reports of progress toward meeting the requirements of any compliance schedule attached or assigned to an approved permit. ()

f. All notices and reports submitted to the Director shall be signed and certified. ()

05. Permit Assignable. Permits may be assigned to a new owner or operator of an injection well if the new owner or operator, within thirty (30) days of the change, notifies the Director of such change. The new owner or operator shall be responsible for complying with the terms and conditions of the permit from the time that such change takes place. ()

058. -- 059. (RESERVED)

060. HEARING BEFORE THE IDAHO WATER RESOURCE BOARD.

01. Hearings on Conditional Permits, Disapproved Applications, or Petitions for Exemption. Any owner or operator aggrieved by the approval or disapproval of an application, or by conditions imposed upon a permit, or any person aggrieved by the Director's decision on a petition for exemption under these rules, shall be afforded an opportunity for a hearing before the Board or its designated hearing officer in accordance with Idaho Code § 42-3909. ()

02. Hearings on Permit Cancellations. The Board shall provide notice and an opportunity for a hearing to the holder of any permit proposed to be cancelled by the Director in accordance with Idaho Code § 42-3910. ()

061. -- 069. (RESERVED)

070. VIOLATIONS, FORMAL NOTIFICATION AND ENFORCEMENT.

01. Violations. It shall be a violation of these rules for any owner or operator to: ()

a. Fail to comply with a permit or authorization, or terms or conditions thereof; ()

b. Fail to comply with applicable standards for water quality; ()

c. Fail to comply with any permit application notification or filing requirement; ()

d. Knowingly make any false statement, representation or certification in any application, report, document or record filed pursuant to these rules, or terms and conditions of an issued permit; ()

e. Falsify, tamper with or knowingly render inaccurate any monitoring device or method required to be maintained or utilized by the terms and conditions of an issued permit; ()

f. Fail to respond to any formal notification of a violation when a response is required; or ()

g. Decommission a well in an unauthorized manner. ()

02. Additional. It shall be a violation of these rules for any person to construct, operate, maintain, convert, plug, decommission or conduct any other activity in a manner which results or may result in the unauthorized injection of a hazardous or radioactive waste by an injection well. ()

03. Enforcement. Violation of any of the provisions of the Injection Well Act (Chapter 39, Title 42, Idaho Code) or of any rule, regulation, standard or criteria pertaining to the Injection Well Act may result in the Director initiating an enforcement action as provided under Chapters 17 and 39, Title 42, Idaho Code. ()

070. CLASS V: CRITERIA AND STANDARDS.

01. ~~Class V Shallow Injection Well Requirements.~~ (3-18-22)

a. ~~Authorization.~~ As a condition of authorization, all owners or operators of shallow Class V injection wells, including improved sinkholes used for aquifer recharge, that dispose of nonhazardous and nonradioactive wastes are required to submit a Shallow Injection Well Inventory Form to the Department no later than thirty (30) days prior to commencement of construction for each new well or no later than thirty (30) days after the discovery of

~~an existing injection well that has not previously been inventoried with the Department. Forms are available from any Department office or at the Department website at <http://www.idwr.idaho.gov>. State or local government entities shall submit the following inventory information for wells associated with highway and street construction and maintenance projects. (3-18-22)~~

- ~~i. Facility name and location; and (3-18-22)~~
- ~~ii. County in which the injection well(s) is (are) located; and (3-18-22)~~
- ~~iii. Ownership of the well(s); and (3-18-22)~~
- ~~iv. Name, address and phone number of legal contact; and (3-18-22)~~
- ~~v. Type or function of the well(s); and (3-18-22)~~
- ~~vi. Number of wells of each type; and (3-18-22)~~
- ~~vii. Operational status of the well(s). (3-18-22)~~

~~**b. Inventory Fees.** For shallow injection wells constructed after July 1, 1997, the Shallow Injection Well Inventory Form shall be accompanied by a fee as specified in Section 42-3905, Idaho Code, payable to the Department of Water Resources. State or local government entities are exempt from Shallow Injection Well Inventory Form filing fees for wells associated with highway and street construction and maintenance, but shall comply with all other requirements of these rules. (3-18-22)~~

~~**e. Permit Requirements.** If operation of a shallow Class V injection well is causing or may cause unreasonable contamination of a USDW, or cause a violation of the ground water quality standards at a place of beneficial use, the Director shall require immediate cessation of the injection activity. Where a Class V injection well is owned or operated by an entity other than a state or local entity involved in highway and street construction and maintenance, the Director may authorize continued operation of the well through a permit that specifies the terms and conditions of acceptable operation. (3-18-22)~~

~~**d. Permanent Decommission.** Owners or operators of shallow injection wells shall notify the Director not less than thirty (30) days prior to permanent decommissioning of any shallow injection well. Permanent decommissioning shall be accomplished in accordance with procedures approved by the Director. (3-18-22)~~

~~**e. Inter-Agency Cooperation.** The Department may seek the assistance of other government agencies, including cities and counties, health districts, highway districts, and other departments of state government to inventory, monitor and inspect shallow injection wells, where local assistance is needed to prevent deterioration of ground water quality, and where injection well operation overlaps with water quality concerns of other agencies or local governing entities. Assistance is to be negotiated through a memorandum of understanding between the Department and the local entity, agency, or department, and is subject to the approval of the Director. (3-18-22)~~

~~**02. Class V Deep Injection Well Requirements. (3-18-22)**~~

~~**a. Application Requirements. (3-18-22)**~~

~~i. No person shall continue to maintain or use an unauthorized injection well after the effective date given in Section 42-3903, Idaho Code, unless a permit therefor has been issued by the Director. No injection well requiring a permit under Subsection 070.02 shall be constructed, modified or maintained after the effective date given in Section 42-3903, Idaho Code, unless a permit therefor has been issued by the Director. No injection well requiring a permit shall continue to be used after the expiration of the permit issued for such well unless another application for permit therefor has been received by the Director. All applications for permit shall be on forms furnished by the Director. (3-18-22)~~

~~ii. Each application for permit to construct, modify or maintain an injection well, as required by these rules, shall be accompanied by a filing fee as specified in Section 42-3905, Idaho Code, payable to the Department of~~

~~Water Resources. For the purposes of these rules, all wells or groups of wells associated with a “Remediation Project” may be administered as one (1) “well” at the discretion of the Director. (3-18-22)~~

~~**b.** Application Information Required. An applicant shall submit the following information to the Director for all injection wells to be authorized by permit, unless the Director determines that it is not needed in whole or in part, and issues a written waiver to the applicant: (3-18-22)~~

- ~~i. Facility name and location; (3-18-22)~~
- ~~ii. Name, address and phone number of the well operator; (3-18-22)~~
- ~~iii. Class, subclass and function of the injection well (see Section 035); (3-18-22)~~
- ~~iv. Latitude/longitude or legal description of the well location to the nearest ten (10) acre tract; (3-18-22)~~
- ~~v. Ownership of the well; (3-18-22)~~
- ~~vi. County in which the injection well is located; (3-18-22)~~
- ~~vii. Construction information for the well; (3-18-22)~~
- ~~viii. Quantity and general character of the injected fluids; (3-18-22)~~
- ~~ix. Status of the well; (3-18-22)~~
- ~~x. A topographic map or aerial photograph extending one (1) mile beyond property boundaries, depicting:
(1) Location of the injection well and associated facilities described in the application; (3-18-22)
(2) Locations of other injection wells; (3-18-22)
(3) Approximate drainage area, if applicable; (3-18-22)
(4) Hazardous waste facilities, if applicable; (3-18-22)
(5) All wells used to withdraw drinking water; (3-18-22)
(6) All other wells, springs and surface waters. (3-18-22)~~
- ~~xi. Distance and direction to nearest domestic well; (3-18-22)~~
- ~~xii. Depth to ground water; and (3-18-22)~~
- ~~xiii. Alternative methods of waste disposal. (3-18-22)~~

~~**e.** Additional Information. The Director may require the following additional information for Class V injection wells to assess potential effects of injection: (3-18-22)~~

- ~~i. A topographic map showing locations of the following within a two (2) mile radius of the injection well:
(1) All wells producing water; (3-18-22)
(2) All exploratory and test wells; (3-18-22)~~

- ~~(3) All other injection wells; (3-18-22)~~
- ~~(4) Surface waters (including man-made impoundments, canals and ditches); (3-18-22)~~
- ~~(5) Mines and quarries; (3-18-22)~~
- ~~(6) Residences; (3-18-22)~~
- ~~(7) Roads; (3-18-22)~~
- ~~(8) Bedrock outcrops; and (3-18-22)~~
- ~~(9) Faults and fractures. (3-18-22)~~
- ~~ii. Additional maps or aerial photographs of suitable scale to accurately depict the following: (3-18-22)~~
 - ~~(1) Location and surface elevation of the injection well described in this permit; (3-18-22)~~
 - ~~(2) Location and identification of all facilities within the property boundaries; (3-18-22)~~
 - ~~(3) Locations of all wells penetrating the proposed injection zone or within a one-quarter (1/4) mile radius of the injection well; (3-18-22)~~
 - ~~(4) Maps and cross sections depicting all underground sources of drinking water to include vertical and lateral limits within a one-quarter (1/4) mile radius of the injection well, their position relative to the injection zone and the direction of water movement; local geologic structures; regional geologic setting. (3-18-22)~~
- ~~iii. A comprehensive report of the following information: (3-18-22)~~
 - ~~(1) A tabulation of all wells penetrating the proposed injection zone, listing owner, lease holder and operator; well identification (permit) number; size, weight, depth and cementing data for all strings of casing; (3-18-22)~~
 - ~~(2) Description of the quality and quantity of fluids to be injected; (3-18-22)~~
 - ~~(3) Geologic, hydrogeologic, and physical characteristics of the injection zone and confining beds; (3-18-22)~~
 - ~~(4) Engineering data for the proposed injection well; (3-18-22)~~
 - ~~(5) Proposed operating pressure; (3-18-22)~~
 - ~~(6) A detailed evaluation of alternative disposal practices; (3-18-22)~~
 - ~~(7) A plan of corrective action for wells penetrating the zone of injection, but not properly sealed or decommissioned; and (3-18-22)~~
 - ~~(8) Contingency plans to cope with all shut-ins or well failures to prevent the migration of unacceptable fluids into underground sources of drinking waters. (3-18-22)~~
- ~~iv. Name, address and phone number of person(s) or firm(s) supplying the technical information and/or designing the injection well; (3-18-22)~~
- ~~v. Proof that the applicant is financially responsible, through a performance bond or other appropriate means, to decommission the injection well in a manner approved by the Director. (3-18-22)~~

~~d. Other Information. The Director may require of any applicant such additional information as may be necessary to demonstrate that the proposed or existing injection well will not endanger a USDW. The Director will not complete the processing of an application for which additional information has been requested until such time as the additional information is supplied. The Director may return any incomplete application and will not process such application until such time as the application is received in complete form. (3-18-22)~~

~~03. Application Processing. (3-18-22)~~

~~a. Draft Permit. After all application information is received and evaluated, the Director will prepare a draft permit or denial, which will include the application for permit, permit conditions or reasons for denial, and any compliance schedules or monitoring requirements. In preparing the draft permit or denial, the Director shall consider the following factors: (3-18-22)~~

~~i. The availability of economic and practical alternative means of disposal; (3-18-22)~~

~~ii. The application of best management practices to the facilities and/or area draining into the well; (3-18-22)~~

~~iii. The availability of economical, practical means of treating or otherwise reducing the amount of contaminants in the injected fluids; (3-18-22)~~

~~iv. The quality of the receiving ground water, its category, its present and future beneficial uses or interconnected surface water; (3-18-22)~~

~~v. The location of the injection well with respect to drinking water supply wells; and (3-18-22)~~

~~vi. Compliance with the IDAPA 58.01.11, "Ground Water Quality Rule." (3-18-22)~~

~~b. Public Notice. The Director will provide public notice of any draft permit to construct, maintain or modify a Class V injection well by means of a legal notice in a newspaper of general circulation in the county in which the well is located. The Director may give additional notice as necessary to adequately inform the interested public and governmental agencies. There shall be a period of at least thirty (30) days following publication for any interested person to submit written comments and to request a fact-finding hearing. The hearing will be held by the Director if deemed necessary. (3-18-22)~~

~~e. Review by the Directors of Other State Agencies. The Directors of other state agencies, as determined by the Director, shall be provided the opportunity to review and comment on draft permits. Comments shall be submitted to the Director within thirty (30) days of the public or legal notice. (3-18-22)~~

~~d. Open-Loop Heat Pump Return Wells (Subclass 5A7). (3-18-22)~~

~~i. An open-loop heat pump return well greater than eighteen (18) feet in depth to be used solely for disposal of heat pump water at a rate not exceeding fifty (50) gpm does not require a draft permit and is not subject to a recurring permit cycle, however, registration of the well with the Department and submittal of a filing fee as specified in Section 42-3905, Idaho Code is required. The Director reserves the right to override the exemptions from the draft permit and permit cycle requirements. (3-18-22)~~

~~ii. An open-loop heat pump return well greater than eighteen (18) feet in depth to be used solely for disposal of heat pump return water at a rate exceeding fifty (50) gpm is subject to the requirements of Subsections 070.02 and 070.03 of these rules. (3-18-22)~~

~~e. Fact-Finding Hearings. At the Director's discretion, or upon motion of any interested individual, the Director may elect to hold a fact-finding hearing. Said hearing will be held at a location in the geographical area of the injection well. Notice of said hearing will be provided at least thirty (30) days in advance of the hearing by regular mail to the applicant and to the person or persons requesting the hearing. Public notice of the fact-finding hearing will be made by means of press release to a newspaper of general circulation in the county of the application. (3-18-22)~~

~~04. The Director's Action On Draft Permits and Duration Of Approved Permits. The role of the Director is to determine whether or not the injection wells and their respective owners or operators are in compliance with the intent of these rules, thus protecting the ground waters of the state against unreasonable contamination or deterioration of quality and preserving them for diversion to beneficial uses. (3-18-22)~~

~~a. Consideration. The Director will consider the following factors in taking final action on draft permits: (3-18-22)~~

~~i. The likelihood and consequences of the injection well system failing; (3-18-22)~~

~~ii. The long term effects of such disposal or storage; (3-18-22)~~

~~iii. The recommendations and related justifications of the Directors of other state agencies and the public; (3-18-22)~~

~~iv. The potential for violation of ground water quality standards at the point of injection or the point of beneficial use; and (3-18-22)~~

~~v. Compliance with the Idaho Ground Water Quality Plan. (3-18-22)~~

~~b. Issuance of Permit. After considering the draft permit for construction, modification, or maintenance, and all matters relating thereto, the Director shall issue a permit if the standards and criteria of Subsection 070.05 will be met and USDW's will not otherwise be unreasonably affected. If the Director finds that the standards and criteria cannot be met or that ground water sources cannot otherwise be protected from unreasonable contamination at all times, the draft permit may be denied or a permit may be issued with conditions designed to protect ground water sources. The Director's decision shall be in writing and a copy shall be mailed by regular mail to the applicant and to all persons who commented in writing on the draft permit or appeared at a hearing held to consider the draft permit. (3-18-22)~~

~~c. Permit Conditions and Requirements. Any permit issued by the Director shall contain conditions to insure that ground water sources will be protected from waste, unreasonable contamination, or deterioration of ground water quality that could result in violations of the ground water quality standards. In addition to specific construction, operation, maintenance and monitoring requirements that the Director finds necessary, each permit shall be subject to the standard conditions and requirements of this rule. (3-18-22)~~

~~d. Construction Requirements. (3-18-22)~~

~~i. Well drillers or other persons involved with the construction of any injection well requiring a permit shall not commence construction on the facility until a certified copy of the approved permit is obtained from the Director. (3-18-22)~~

~~ii. Deep injection wells shall be constructed by a licensed water well driller to conform with the current Minimum Well Construction Standards and the conditions of the permit, except that a driller's license is not required for the construction of a driven mine shaft or a dug hole. (3-18-22)~~

~~iii. Shallow injection wells authorized by permit shall be constructed in accordance with the conditions of the permit. Rule authorized shallow injection wells shall be constructed as shown or described in the inventory submittal. (3-18-22)~~

~~iv. Injection wells shall be constructed to prevent the entrance of any fluids other than specified in the permit. (3-18-22)~~

~~v. Injection wells shall be constructed to prevent waste of artesian fluids or movement of fluids from one aquifer into another. (3-18-22)~~

~~vi. When construction or modification of an injection well has been completed, the owner or operator~~

- ~~shall inform the Director of completion on a form provided by the Department. (3-18-22)~~
- ~~vii. A sampling port shall be provided if the injection well system is enclosed. (3-18-22)~~
 - ~~viii. All new injection wells constructed into alluvial formations shall have a minimum ten (10) foot separation from the bottom of the well and seasonal high ground water. (3-18-22)~~
 - ~~(1) Injection wells installed into fractured basalt are exempt from separation distances. (3-18-22)~~
 - ~~(2) The Director may reduce separation distance requirements if the quality of injected fluids are improved through additional treatment or BMPs. (3-18-22)~~
 - ~~(3) Heat pump return wells (sub-class 5A7) are exempt from the separation distance requirement of this section. (3-18-22)~~
 - ~~e. Operational Conditions. (3-18-22)~~
 - ~~i. The injection well shall not be used until the construction, operation and maintenance requirements of the permit are met and provisions are made for any required inspection, monitoring and record keeping. (3-18-22)~~
 - ~~ii. Injection of any contaminant at concentrations exceeding the standards set in Paragraph 070.05.e. into a present or future drinking or other ground water source that may cause a health hazard or adversely affect a designated and protected use is prohibited. (3-18-22)~~
 - ~~iii. The injection well owner or operator shall develop approved procedures to detect constructional or operational failure in a timely fashion, and shall have contingency plans to cope with the well failure. (3-18-22)~~
 - ~~iv. Authorized representatives of the Department shall be allowed to enter, inspect and/or sample: (3-18-22)~~
 - ~~(1) The injection well and related facilities; (3-18-22)~~
 - ~~(2) The owner or operator's records of the injection operation; (3-18-22)~~
 - ~~(3) Monitoring instrumentation associated with the injection operation; and (3-18-22)~~
 - ~~(4) The injected fluids. (3-18-22)~~
 - ~~v. The injection facilities shall be operated and maintained to achieve compliance with all terms and conditions of this permit. (3-18-22)~~
 - ~~(1) Proper operation and maintenance includes effective performance, adequate funding, operator staffing and training, and adequate laboratory and process controls, including appropriate quality assurance procedures; (3-18-22)~~
 - ~~(2) If compliance cannot be met, the owner shall take corrective action as determined by the Director or terminate injection. (3-18-22)~~
 - ~~vi. The owner shall mitigate any adverse effects resulting from non-compliance with the terms and conditions of the permit. (3-18-22)~~
 - ~~vii. If the injection well was constructed prior to issuance of the permit, the well shall be brought into compliance with the terms and conditions of the permit in accordance with the schedule of compliance issued by the Director. (3-18-22)~~
 - ~~viii. The permit shall not convey any property rights. (3-18-22)~~

- ~~f. Conditions of Permanent Decommissioning. (3-18-22)~~
- ~~i. Notice of intent to permanently decommission a well shall be submitted to the Director not less than thirty (30) days prior to commencement of the decommissioning activity. (3-18-22)~~
- ~~ii. The method of permanent decommissioning for all injection wells shall be approved by the Director prior to commencement of the decommissioning activity. (3-18-22)~~
- ~~iii. Notice of completion of permanent decommission shall be submitted to the Director within thirty (30) days of completion. (3-18-22)~~
- ~~iv. All deep injection wells that are to be permanently decommissioned shall be plugged in accordance with current Well Construction Standards. (3-18-22)~~
- ~~v. Following permanent cessation of use, or where an injection well is not completed, the Director shall be notified. Decommissioning procedures or other action, as prescribed by the Director, shall be conducted. (3-18-22)~~
- ~~vi. The injection well owner or operator has the responsibility to insure that the injection operation is decommissioned as prescribed. (3-18-22)~~
- ~~g. Duration of Approved Permits. The length of time that a permit may be in effect for Class V wells requiring permits shall not exceed ten (10) years. (3-18-22)~~
- ~~05. Standards For The Quality of Injected Fluids and Criteria For Location and Use. (3-18-22)~~
- ~~a. General. These standards, which are minimum standards that are to be adhered to for all deep injection wells and shallow injection wells requiring permits and rule authorized wells not requiring permits, are based on the premise that if the injected fluids meet ground water quality standards for physical, chemical and radiological contaminants, and if ground water produced from adjacent points of diversion for beneficial use meets the water quality standards as defined in Section 010 of these rules, then that aquifer will be protected from unreasonable contamination and will be preserved for diversion to beneficial uses. The Director may, however, when it is deemed necessary, require specific injection wells to be constructed and operated in compliance with additional requirements, such as best management practices (BMPs), so as to protect the ground water resource from deterioration and preserve it for diversion to beneficial use. (3-18-22)~~
- ~~b. Waivers. A waiver of one (1) or more standards may be granted by the Director if it can be demonstrated by the applicant that the contaminants in injected fluid will not endanger a ground water source for any present or future beneficial use. (3-18-22)~~
- ~~e. Standards for Quality of Fluids Injected into Class V Wells. (3-18-22)~~
- ~~i. Ground water quality standards for chemical and radiological contaminants in injected fluids. After the effective date of these standards, the following limits shall not be exceeded in injected fluids from a well when such fluids will or are likely to reach a USDW: (3-18-22)~~
- ~~(1) Chemical contaminants. The concentration of each chemical contaminant in the injected fluids shall not exceed the ground water quality standard for that chemical contaminant, or the concentration of each contaminant in the receiving water, whichever requirement is less stringent; and (3-18-22)~~
- ~~(2) Radiological contaminants. Radiological levels of the injected fluids shall not exceed those levels specified by the ground water quality standards. (3-18-22)~~
- ~~ii. Restrictions on injection of fluids containing biological contaminants. The following restrictions apply to biological contaminants included in the ground water quality standard in injected fluids. Coliform bacteria: injected fluids containing coliform bacteria are subject to the following restrictions: (3-18-22)~~

~~(1) Contamination of ground water produced at any existing point of diversion for beneficial use, or any point of diversion for beneficial use developed in the future, by injected fluids is prohibited; (3-18-22)~~

~~(2) The Director may require the use of best management practices (BMPs) to reduce the concentration of coliform bacteria in the injected fluids; (3-18-22)~~

~~(3) The Director may require the use of water treatment technology, including ozonation and chlorination devices, sand filters, and settling pond specifications to reduce the concentration of coliform bacteria in injected fluids; (3-18-22)~~

~~(4) Ground water produced from points of diversion for beneficial use adjacent to injection wells that dispose of fluids containing coliform bacteria in concentrations greater than the current ground water quality standard shall be subject to monitoring for bacteria by the owner/operator of the injection well. A waiver of the monitoring requirement may be granted by the Director when it can be demonstrated that injection will not result in unreasonable contamination of ground water produced from these adjacent points; (3-18-22)~~

~~(5) Construction of new Subclass 5F1 injection wells, and other shallow and deep injection wells, as specified by the Director, that are likely to exceed the current ground water quality standard for coliform bacteria at the point of beneficial use is prohibited; and (3-18-22)~~

~~(6) At no time shall any fluid containing or suspected of containing fecal contaminants of human origin be injected into any Class V injection well authorized under these rules. (3-18-22)~~

~~iii. Physical, visual and olfactory characteristics. The following restrictions apply to physical, visual and olfactory characteristics of injected fluids. Temperature, color, odor, turbidity, conductivity and pH: the temperature, color, odor, conductivity, turbidity, pH or other characteristics of the injected fluid may not result in the receiving ground water becoming less suitable for diversion to beneficial uses, as determined by the Director. (3-18-22)~~

~~iv. Contamination by an injection well of ground water produced at an existing point of diversion for beneficial use, or a point of diversion for beneficial use developed in the future, shall not exceed water quality standards defined in Section 010 of these rules. (3-18-22)~~

~~**d. Criteria for Location and Use of Class V Wells Requiring Permits. (3-18-22)**~~

~~i. A Class V well requiring a permit may be required to be located a minimum distance, as determined from Table 1, from any point of diversion for beneficial use that could be harmed by bacterial contaminants. This requirement is not applicable to injection wells injecting wastes of quality equal to or better than adopted ground water quality standards in all respects. In addition, Class V wells may be required to be located at such a distance from a point of diversion for beneficial use as to minimize or prevent ground water contamination resulting from unauthorized or accidental injection, as determined by the Director. (3-18-22)~~

~~ii. These location requirements in Table 1 may be waived, as per Paragraph 070.05.b., when the applicant can demonstrate that any springs or wells within the calculated perimeter of the generated perched water zone will not be contaminated by the applicant's waste disposal or injection well. Monitoring by the applicant of the production wells or springs in question may be required to demonstrate that they are not being contaminated.~~

Determined Radii of Perched Water Zones Based on Maximum Average Weekly Injection Rates (cfs) of Class V Injection Wells *	
Injection (cfs)	Radius of Generated Perched Water Zone (ft)
0-0.20	800
0.20-0.60	1,400
0.61-1.00	1,800

Determined Radii of Perched Water Zones Based on Maximum Average Weekly Injection Rates (cfs) of Class V Injection Wells *	
Injection (cfs)	Radius of Generated Perched Water Zone (ft)
1.01—2.00	2,500
2.01—3.00	3,000
3.01—4.00	3,500
4.01—5.00	4,000
Greater than 5.00	As determined by the Director

* Injection rates shall be based on the average volume of wastes injected by the well during the week of greatest injection in an average water year. (3-18-22)

~~e. Standards for the Quality of Fluids Injected by Subclass 5A7 Wells (Open Loop Heat Pump Return). (3-18-22)~~

~~i. The quality of fluids injected by a Subclass 5A7 injection well shall comply with ground water quality standards or shall be equal to the quality of the ground water source to the heat pump, whichever is less stringent. (3-18-22)~~

~~ii. If the quality of the ground water source does not meet ground water quality standards, the injected fluids must be returned to the formation containing the ground water source. (3-18-22)~~

~~iii. The temperature of the injected fluids shall not impair the designated beneficial uses of the receiving ground water. (3-18-22)~~

~~iv. All Rule-authorized Injection Wells shall conform to the ground water quality standards at the point of injection and not cause any water quality standards to be violated at any point of beneficial use. (3-18-22)~~

~~**06. Monitoring, Record Keeping and Reporting Requirements.** The Director may require monitoring, record keeping and reporting by any owner or operator if the Director finds that the well may adversely affect a ground water source or is injecting a contaminant that could have an unacceptable effect upon the quality of the ground waters of the state. (3-18-22)~~

~~a. Monitoring. (3-18-22)~~

~~i. Any injection authorized by the Director shall be subject to monitoring and record keeping requirements as conditions of the permit. Such conditions may require the installation, use and maintenance of monitoring equipment or methods. The Director may require where appropriate, but is not limited to, the following: (3-18-22)~~

~~(1) Monitoring of injection pressures and pressures in the annular space between casings; (3-18-22)~~

~~(2) Flow rate and volumes; (3-18-22)~~

~~(3) Analysis of quality of the injected fluids for contaminants that are subject to limitation or reduction under the conditions of the permit; or contaminants which the Director determines could have an unacceptable effect on the quality of the ground waters of the state, and which the Director has reason to believe are in the injected fluids; (3-18-22)~~

~~(4) Monitoring of ground water through special monitoring wells or existing points of diversion for beneficial use in the zone of influence as determined by the Director; (3-18-22)~~

- (5) A demonstration of the integrity of the casing, tubing or seal of the injection well. (3-18-22)
 - ii. The frequency of required monitoring shall be specified in the permit when issued, except that the Director at any time may, in writing, require additional monitoring and reporting. (3-18-22)
 - iii. All monitoring tests and analysis required by permit conditions shall be performed in a state certified laboratory or other laboratory approved by the Director. (3-18-22)
 - iv. Any field instrumentation used to gather data, when specified as a condition of the permit, shall be required by the Director to be tested and maintained in such a manner as to ensure the accuracy of the data. (3-18-22)
 - v. All samples and measurements taken for the purpose of monitoring shall be representative of the monitoring activity and fluids injected. (3-18-22)
- ~~b.~~ Record Keeping. The permittee shall maintain records of all monitoring activities to include: (3-18-22)
 - i. Date, time and exact place of sampling; (3-18-22)
 - ii. Person or firm performing analysis; (3-18-22)
 - iii. Date of analysis, analytical methods used and results of analysis; (3-18-22)
 - iv. Calibration and maintenance of all monitoring instruments; and (3-18-22)
 - v. All original tapes, strip charts or other data from continuous or automated monitoring instruments. (3-18-22)
- ~~e.~~ Reporting. (3-18-22)
 - i. Monitoring results obtained by the permittee pursuant to the monitoring requirements prescribed by the Director shall be reported to the Director as required by permit conditions. (3-18-22)
 - ii. The Director shall be notified in writing by the permittee within five (5) days after the discovery of violation of the terms and conditions of the permit. If the injection activity endangers human health or a public or domestic water supply, use of the injection well shall be immediately discontinued and the owner or operator shall immediately notify the Director. Notification shall contain the following information: (3-18-22)
 - (1) A description of the violation and its cause; (3-18-22)
 - (2) The duration of the violation, including dates and times; if not corrected or use of the well discontinued, the anticipated time of correction; and (3-18-22)
 - (3) Steps being taken to reduce, eliminate and prevent recurrence of the injection. (3-18-22)
 - iii. Where the owner or operator becomes aware of failure to submit any relevant facts in any permit application or report to the Director, that person shall promptly submit such facts or information. (3-18-22)
 - iv. The permittee shall furnish the Director, within a time specified by the Director, any information which the Director may request to determine compliance with the permit. (3-18-22)
 - v. All applications for permits, notices and reports submitted to the Director shall be signed and certified. (3-18-22)
 - vi. The Director shall be notified in writing of planned physical alterations or additions to any facility related to the permitted injection well operation. (3-18-22)

- vii. ~~Additional information to be reported to the Director in writing; (3-18-22)~~
- (1) ~~Transfer of ownership; (3-18-22)~~
- (2) ~~Any change in operational status not previously reported; (3-18-22)~~
- (3) ~~Any anticipated noncompliance; and (3-18-22)~~
- (4) ~~Reports of progress toward meeting the requirements of any compliance schedule attached or assigned to this permit. (3-18-22)~~

~~**07. Permit Assignable.** Permits may be assignable to a new owner or operator of an injection well if the new owner or operator, within thirty (30) days of the change, notifies the Director of such change. The new owner or operator shall be responsible for complying with the terms and conditions of the permit from the time that such change takes place. (3-18-22)~~

071. -- 999. (RESERVED)

IDAPA 37 – IDAHO DEPARTMENT OF WATER RESOURCES

37.03.09 – WELL CONSTRUCTION STANDARDS RULES

DOCKET NO. 37-0309-2401 (ZBR CHAPTER REWRITE)

NOTICE OF RULEMAKING – PROPOSED RULE

AUTHORITY: In compliance with Section 67-5221(1), Idaho Code, notice is hereby given that this agency has initiated proposed rulemaking procedures. The action is authorized pursuant to Section 42-1805(8), Idaho Code.

PUBLIC HEARING SCHEDULE: Public hearing(s) concerning this rulemaking will be scheduled if requested in writing by twenty-five (25) persons, a political subdivision, or an agency, not later than October 16, 2024.

The hearing site(s) will be accessible to persons with disabilities. Requests for accommodation must be made not later than five (5) days prior to the hearing, to the agency address below.

DESCRIPTIVE SUMMARY: The following is a nontechnical explanation of the substance and purpose of the proposed rulemaking:

The Idaho Department of Water Resources (IDWR) initiated this rulemaking in compliance with [Executive Order No. 2020-01, Zero-Based Regulation \(ZBR\)](#) (EO 2020-01), issued by Governor Little on January 16, 2020. Pursuant to EO 2020-01, each rule chapter effective on June 30, 2020, must be reviewed by the promulgating agency over a five-year period. This review is being conducted according to a schedule established by the Division of Financial Management, Office of the Governor (DFM), posted at https://adminrules.idaho.gov/forms_menu.html. This rule chapter was scheduled for review in 2023.

With this Notice, IDWR proposes a new chapter of well construction standards rules. The new chapter is approximately 5.8% shorter than the existing well construction standards rule chapter due to both internal agency analysis and external stakeholder negotiation, commentary, and editing. Changes to the rule come through a combination of (a) removal of obsolete, (b) removal of unnecessary provisions (such as the prescriptive casing and sealing requirements for low temperature geothermal (LTG) resource wells), and (c) modifications to existing rules regulating improving its effectiveness.

The development of the proposed rule text through two publicly-released preliminary rule draft iterations may be viewed at: <https://idwr.idaho.gov/legal-actions/rules/idwr-rulemaking-2024-2025/well-construction-rules/>. On the same website, IDWR also developed and published rulemaking support documents, which provide IDWR's recommendations on rulemaking, rulemaking analysis, and responses to substantive comments received through the negotiated rulemaking process.

After consideration of public comments received in response to this Proposed Rule, IDWR will present the final rule text during the 2025 Legislative Session.

FEE SUMMARY: The following is a specific description of the fee or charge imposed or increased:

IDAPA 37.03.09 sets the procedures for drilling and constructing wells to prevent waste and contamination of Idaho's ground water resources. The rule also establishes the collection of fees to file an application for drilling permit set forth in Idaho Code § 42-235.

FISCAL IMPACT: The following is a specific description, if applicable, of any negative fiscal impact on the state General Fund greater than ten thousand dollars (\$10,000) during the fiscal year resulting from this rulemaking: N/A.

NEGOTIATED RULEMAKING: Pursuant to Section 67-5220(1), Idaho Code, negotiated rulemaking was conducted. The Notice of Intent to Promulgate Rules - Negotiated Rulemaking was published in the April 3, 2024 Idaho [Administrative Bulletin, Vol. 24-4, page 54](#).

INCORPORATION BY REFERENCE: Pursuant to Section 67-5229(2)(a), Idaho Code, the following is a brief synopsis of why the materials cited are being incorporated by reference into this rule: N/A.

ASSISTANCE ON TECHNICAL QUESTIONS, SUBMISSION OF WRITTEN COMMENTS: For assistance on technical questions concerning the proposed rule, contact Erik Boe at Erik.Boe@idwr.idaho.gov, (208) 287-4800.

Anyone may submit written comments regarding this proposed rulemaking by mail to the address below or by email sent to rulesinfo@idwr.idaho.gov. All written comments must be directed to the undersigned and must be delivered on or before October 23, 2024.

DATED this 30th day of August 2024.

Erik Boe, Water Compliance Bureau Chief, Rules Regulation Officer
Idaho Department of Water Resources
322 E. Front Street
PO Box 83720 Boise, ID 83720-0098
Phone: (208) 287-4800

THE FOLLOWING IS THE PROPOSED TEXT OF DOCKET NO. 37-0309-2401
(ZBR Chapter Rewrite)

37.03.09 – WELL CONSTRUCTION STANDARDS RULES

000. LEGAL AUTHORITY (RULE 0).

~~The Idaho Water Resource Board adopts these administrative rules with the authority provided by Section 42-238(12), Idaho Code.~~ (3-18-22)()

001. ~~TITLE AND SCOPE (RULE 1).~~

~~01. Title.~~ These rules are cited as IDAPA 37.03.09, “Well Construction Standards Rules.” (3-18-22)

~~02. Scope.~~ The Department of Water Resources has statutory responsibility for the statewide administration of the rules governing well construction. These rules establish minimum standards for the construction of all new wells and the modification and decommissioning (~~abandonment~~) of existing wells. The intent of the rules is to protect the ground water resources of the state against waste and contamination. These rules are applicable to all water wells, monitoring wells, low temperature geothermal wells, injection wells, cathodic protection wells, closed loop heat exchange wells, and other artificial openings and excavations in the ground that are more than eighteen (18) feet in vertical depth below land surface as described in these rules pursuant to Section 42-230 Idaho Code. ~~Some artificial openings and excavations do not constitute a well. For the purposes of these rules, artificial openings and excavations not defined as wells are described in Subsection 045.03 of these rules. Any time that such an artificial opening or excavation is constructed, modified, or decommissioned (abandoned) the intent of these rules must be observed. If waste or contamination is attributable to this type of artificial opening or excavation, the artificial opening or excavation must be modified, or decommissioned (abandoned) as determined by the Director.~~ (3-18-22)()

002. -- 009. (RESERVED)

010. DEFINITIONS (RULE 10).

~~Unless the context otherwise requires, the following definitions apply to these rules.~~ (3-18-22)

01. Approved Seal or Seal Material. Seal material must consist of bentonite chips, pellets, or granules, bentonite grout, neat cement, or neat cement grout as defined by these rules. ~~No other materials may be used~~

~~unless specifically authorized by the Director~~

~~(3-18-22)()~~

02. Annular Space. The space, measured as one-half (1/2) the difference in diameter between two (2) concentric cylindrical objects, one of which surrounds the other, such as the space between the walls of a drilled hole (borehole) and a casing or the space between two (2) strings of casing. (3-18-22)

03. Aquifer. Any geologic formation(s) that will yield water to a well in sufficient quantities to make the production of water from the formation feasible for beneficial use. (3-18-22)

04. Area of Drilling Concern. An area designated by the Director in which drillers must comply with additional standards to prevent waste or contamination of ground or surface water due to such factors as aquifer pressure, vertical depth of the aquifer, warm or hot ground water, or contaminated ground or surface waters, in accordance with Section 42-238(715), Idaho Code. (3-18-22)()

05. Artesian Water. Any water that is confined in an aquifer under pressure so that the water will rise in the well casing or drilled hole above the elevation where it was first encountered. This term includes water of flowing and non-flowing wells. (3-18-22)

06. Artificial Filter Pack. Clean, rounded, smooth, uniform, sand or gravel placed in the annular space around a perforated well casing or well screen. A filter pack is frequently used to prevent the movement of finer material into the well casing and to increase well efficiency. (3-18-22)

07. Bentonite. A commercially processed and packaged, low permeability, sodium montmorillonite clay certified by the NSF International for use in well construction, sealing, plugging, and decommissioning (~~abandonment~~). All bentonite products used in the construction or decommissioning (~~abandoning~~) of wells must have a permeability rating not greater than 10^{-7} (ten to the minus seven) cm/sec. (3-18-22)()

a. Chips. Bentonite composed of pieces ranging in size from one-quarter (1/4)-inch to one (1) inch on their greatest dimension. (3-18-22)

b. Granules (also Granular). Bentonite composed of pieces ranging in size from one thirty-seconds (1/32) inch (#20 standard mesh) to seven thirty-seconds (7/32) inch (#3 standard mesh) on their greatest dimension. (3-18-22)

c. Bentonite Grout. A mixture of bentonite specifically manufactured for use as a well sealing or plugging material and potable water to produce a grout with an active solids content not less than twenty-five percent (25%) by weight e.g., (twenty-five percent (25%) solids content by weight = fifty (50) pounds bentonite per eighteen (18) gallons of water). (3-18-22)

d. Pellets (~~also Tablets~~). ~~Bentonite manufactured for a specific purpose and composed of uniform sized, one quarter (1/4) inch, three eighths (3/8) inch, or one half (1/2) inch pieces on their greatest dimension~~ High swelling sodium bentonite compressed into pellet form, including pellets coated with a time release biodegradable coating. (3-18-22)()

08. Board. The Idaho Water Resource Board. (3-18-22)

09. Bore Diameter. The diameter of the hole in the formation made by the drill bit or reamer. (3-18-22)

10. Borehole (also Well Bore and Boring). The subsurface hole created during the drilling process. (3-18-22)()

11. Bottom Hole Temperature ~~of an Existing or Proposed Well~~. The temperature of the ground water encountered in the bottom of a well or borehole. (3-18-22)()

12. Casing. The permanent ~~conduit~~ steel or thermoplastic pipe installed in a well to ~~provide physical stabilization, prevent caving or collapse of the borehole,~~ maintain the well opening and serve as a solid inner barrier

to allow for the installation of an annular seal. ~~Casing does not include temporary surface casing, well screens, liners, or perforated casing as otherwise defined by these rules.~~ (3-18-22)()

13. Cathodic Protection Well. Any artificial excavation ~~in excess of~~ more than eighteen (18) feet in vertical depth constructed for the purpose of protecting certain metallic equipment in contact with the ground. Commonly referred to as cathodic protection. (3-18-22)()

14. Closed Loop Heat Exchange Well. A ~~ground source thermal exchange well constructed for the purpose of installing any underground system~~ through which thermal exchange fluids are circulated but remain isolated from direct contact with the subsurface or ground water. (3-18-22)()

15. Conductor Pipe. The first and largest diameter string of permanent casing ~~to be~~ installed in a ~~low temperature geothermal resource~~ well when multiple casing strings are necessary. (3-18-22)()

16. Confining Layer. A subsurface zone of low-permeability earth material that naturally acts to restrict or retard the movement of water or contaminants from one zone to another. ~~The term does not include topsoil.~~ (3-18-22)()

17. Consolidated Formations. Naturally-occurring geologic formations that have been lithified (turned to stone) such as sandstone and limestone, or igneous rocks such as basalt and rhyolite, and metamorphic rocks such as gneiss and slate. (3-18-22)

18. Contaminant. ~~Any physical, chemical, ion, radionuclide, synthetic organic compound, microorganism, waste, or other substance that does not occur naturally in ground water or that naturally occurs at a lower concentration.~~ Any physical, chemical, biological, or radiological substance or matter. (3-18-22)()

19. Contamination. The introduction into the natural ground water of any physical, chemical, biological or radioactive material that may: (3-18-22)

a. ~~Cause a violation of Idaho Ground Water Quality Standards; or~~ Cause a violation of Standards found in IDAPA 58.01.11, "Ground Water Quality Rule," or primary federal drinking water regulation found in 40 CFR Parts 141 and 142 whichever is more stringent.; or (3-18-22)()

b. Adversely affect the health of the public; or (3-18-22)

c. Adversely affect a designated or beneficial use of the State's ground water. Contamination includes the introduction of heated or cooled water into the subsurface that will alter the ground water temperature and render the local ground water less suitable for beneficial use, ~~or the introduction of any contaminant that may cause a violation of IDAPA 58.01.11, "Ground Water Quality Rule."~~ (3-18-22)()

20. Decommissioned (Abandoned) Well. Any well that has been permanently removed from service and filled or plugged in accordance with these rules ~~so as~~ to meet the intent of these rules. A properly decommissioned well will not: (3-18-22)()

a. Produce or accept fluids; (3-18-22)

b. Serve as a conduit for the movement of contaminants inside or outside the well casing; or (3-18-22)

c. Allow the movement of surface or ground water into unsaturated zones, into another aquifer, or between aquifers. (3-18-22)

21. Decontamination. The process of cleaning removing contaminants from equipment intended for use in a well ~~in order to prevent the introduction of contaminants into the subsurface and contamination of natural ground water.~~ (3-18-22)()

22. Department. The Idaho Department of Water Resources. (3-18-22)

- 23. Dewatering Well.** A well constructed for the purpose of improving slope stability, drying up ~~borrow pits~~ land, or intercepting seepage that would otherwise enter an excavation. (3-18-22)()
- 24. Director.** The Director of the Idaho Department of Water Resources ~~or his duly authorized representatives.~~ (3-18-22)()
- 25. Disinfection.** The introduction of chlorine or other agent or process approved by the Director in sufficient concentration and for the time required to inactivate or kill fecal and Coliform bacteria, indicator organisms, and other ~~potentially harmful~~ pathogens. (3-18-22)()
- 26. Draw Down.** The difference in vertical distance between the static water level and the pumping water level. (3-18-22)
- 27. Drive Point (also known as a Sand Point).** A conduit ~~pipe or casing~~ through which ground water of any temperature is sought or encountered; created by joining a “drive point unit” to a length of pipe and driving the assembly into the ground. (3-18-22)()
- ~~**28. Exploratory Well.** A well drilled for the purpose of discovering or locating new resources in unproven areas. They are used to extract geological, hydrological, or geophysical information about an area. (3-18-22)~~
- ~~**29. Global Positioning System (GPS).** A global navigational receiver unit and satellite system used to triangulate a geographic position. (3-18-22)~~
- ~~**30. Hydraulic Conductivity.** A measurement of permeability. (3-18-22)~~
- 28. Geotechnical Borings.** Borings drilled for the sole purpose of obtaining soil samples or other data to determine subsurface geologic properties. ()
- ~~**31.29. Hydraulic Fracturing.** A process whereby water or other fluid is pumped under high pressure into a well to further fracture the reservoir rock or aquifer surrounding the production zone of a well to increase well yield. (3-18-22)~~
- ~~**32.0. Injection Well.** Any excavation or artificial opening into the ground which meets the following three (3) criteria Any feature that is operated to allow the subsurface emplacement of fluids that also meets at least one (1) of the following criteria: (3-18-22)()~~
- ~~**a.** It is a bored, drilled or dug hole, or is a driven mine shaft or driven well point; and (3-18-22)~~
- ~~**b.** It is deeper than its largest straight line surface dimension; and (3-18-22)~~
- ~~**c.** It is used for or intended to be used for subsurface placement of fluids. (3-18-22)~~
- a.** A bored, or driven shaft whose depth is greater than the largest surface dimension; ()
- b.** A dug hole whose depth is greater than the largest surface dimension; ()
- c.** An improved sinkhole; or ()
- d.** A subsurface fluid distribution system. ()
- 33.1. Intermediate String or Casing.** ~~The e~~ Casing installed and sealed below the surface casing within a low temperature geothermal resource well to isolate undesirable water or zones below the bottom of the surface first string of permanent casing. Such strings may either be lapped into the ~~surface~~ casing above it or extend to land surface. (3-18-22)()

- 342. Liner.** (3-18-22)
- a.** A conduit removable steel or thermoplastic pipe ~~that can be removed from the borehole or well that is used to serve~~ as access and protective housing for pumping equipment and provide a pathway for the upward flow of water within the well. (3-18-22)()
- b.** ~~Liner does not include casing required to prevent caving or collapse, or both, of the borehole or serve as a solid inner barrier to allow for the installation of an annular seal.~~ (3-18-22)
- 35. Mineralized Water.** ~~Any naturally occurring ground water that has an unusually high amount of chemical constituents dissolved within the water. Water with five thousand (5000) mg/L or greater total dissolved solids is considered mineralized.~~ (3-18-22)
- 363. Modify.** To deepen a well, increase or decrease the diameter of the casing or the well bore, install a liner, place a screen, perforate existing casing or liner, alter the seal between the casing and well bore, or alter the well to not meet well construction standards. (3-18-22)
- 374. Monitoring Well.** Any well ~~more than eighteen (18) feet in vertical depth constructed~~ used to evaluate, observe or determine the quality, quantity, temperature, pressure or other characteristics of the ground water or aquifer. (3-18-22)()
- 385. Neat Cement.** A mixture of water and cement in the ratio of not more than six (6) gallons of water to ninety-four (94) pounds of Portland cement ~~(neat cement)~~. Other neat cement ~~grout~~ mixes may be used if specifically approved by the Director. (3-18-22)()
- 396. Neat Cement Grout.** Up to five percent (5%) bentonite by dry weight may be added per sack of cement ~~(neat cement grout)~~ and the water increased to not more than six and one-half (6.5) gallons per sack of cement. Other neat cement grout mixes may be used if specifically approved by the Director. These grouts must be mixed and installed in accordance with the American Petroleum Institute Standards - API Class A through H. As found in API RP10B, "Recommended Practice for Testing Oil Well Cements and Cement Additives," current edition or other approved standards. (3-18-22)()
- 4037. Oxidized Sediments.** Sediments, characterized by distinct coloration, typically shades of brown, red, or tan, caused by the alteration of certain minerals in an environment with a relative abundance of oxygen. (3-18-22)
- 4138. Perforated Well Casing.** Well casing that has been modified by the addition of openings created by drilling, torch cutting, saw cutting, mechanical down-hole perforator, or other method. (3-18-22)
- 4239. Pitless Adaptor or Pitless Unit.** ~~An assembly of parts designed for attachment to a well casing which allows buried pipe to convey water from the well or pump and allows access to the interior of the well casing for installation or removal of the pump or pump appurtenances, while maintaining a water tight connection through the well casing and preventing contaminants from entering the well. An assembly that provides a watertight connection between the pump installed inside the well casing and buried pipe outside the well casing.~~ (3-18-22)()
- 430. Potable Water.** Water of adequate quality for human consumption. (3-18-22)
- 441. Pressure Grouting (Grouting).** The process of pumping and placing an approved grout mixture into the required annular space, well bore, casing or screens by positive displacement from bottom to top using a tremie pipe, Halliburton method, float shoe, or other method approved by the Director. (3-18-22)()
- 452. Production Casing.** The final string of casing or tubing ~~through which a low temperature geothermal resource is produced. This string extends~~ extending from the producing zone to land surface. (3-18-22)()
- 46. Public Water System.** ~~A system for the provision to the public of water for human consumption~~

~~through pipes or, after August 5, 1998, other constructed conveyances, if such system has at least fifteen (15) service connections, regardless of the number of water sources or configuration of the distribution system, or regularly serves an average of at least twenty-five (25) individuals daily at least sixty (60) days out of the year. Such term includes:~~ (3-18-22)

~~a. Any collection, treatment, storage, and distribution facilities under the control of the operator of such system and used primarily in connection with such system; and~~ (3-18-22)

~~b. Any collection or pretreatment storage facilities not under such control that are used primarily in connection with such system.~~ (3-18-22)

~~c. Such term does not include any "special irrigation district."~~ (3-18-22)

~~d. A public water system is either a "community water system" or a "non-community water system."~~ (3-18-22)

43. Public Drinking Water System. A system for the provision to the public of water for human consumption through pipes or, after August 5, 1998, other constructed conveyances, if such system has at least fifteen (15) service connections, regardless of the number of water sources or configuration of the distribution system, or regularly serves an average of at least twenty-five (25) individuals daily at least sixty (60) days out of the year. Such term includes: any collection, treatment, storage, and distribution facilities under the control of the operator of such system and used primarily in connection with such system; and any collection or pretreatment storage facilities not under such control which are used primarily in connection with such system. Such term does not include any "special irrigation district." A public drinking water system is either a "community water system" or a "noncommunity water system" as further defined as: ()

a. Community water system. A public drinking water system which serves at least fifteen (15) service connections used by year-round residents or regularly serves at least twenty-five (25) year-round residents. ()

b. Noncommunity water system. A public drinking water system that is not a community water system. A non-community water system is either a transient noncommunity water system or a non-transient noncommunity water system. ()

c. Nontransient noncommunity water system. A public drinking water system that is not a community water system and that regularly serves at least twenty-five (25) of the same persons over six (6) months per year. ()

d. Transient noncommunity public drinking water system. A noncommunity water system which does not regularly serve at least twenty-five (25) of the same persons over six (6) months per year. ()

474. Reduced Sediments. Sediments, characterized by distinct coloration, typically shades of blue, black, gray, or green, caused by the alteration of certain minerals in an oxygen poor environment. (3-18-22)

485. Remediation Well. A well used to inject or withdraw fluids, vapor, or other solutions approved by the Director for the purposes of remediating, enhancing quality, or controlling potential or known contamination. Remediation wells include those used for air sparging, vapor extraction, or injection of chemicals for remediation or in-situ treatment of contaminated sites. (3-18-22)

496. Sand. Any sediment particle retained on a U.S. standard sieve #200 (Seventy-five hundredths (0.075) mm to two (2) mm). (3-18-22)

507. Screen (Well Screen). A commercially produced structural tubular retainer with standard sized openings to facilitate production of sand free water. (3-18-22)

518. Seal or Sealing. The placement of approved seal material in the required annular space between a borehole and casing, between casing strings, or as otherwise required to create a low permeability barrier and prevent movement or exchange of fluids. ~~Seals are required in the construction of new wells, repair of existing wells, and in~~

~~the decommissioning (abandonment) of wells. Seals are essential to the prevention of waste and contamination of ground water.~~ (3-18-22)()

5249. Start Card. An expedited drilling permit process for the construction of cold water, single-family residential wells. (3-18-22)

530. Static Water Level. The ~~height at which~~ depth to water ~~will rise~~ in a well under non-pumping conditions. (3-18-22)()

541. Surface Casing. The first string of casing in a low temperature geothermal resource well which is set and sealed after the conductor pipe to anchor blow out prevention equipment and to case and seal out all existing cold ground water zones. (3-18-22)

552. Temporary—Surface Casing. Steel pipe used to support the borehole within unstable or unconsolidated formations during construction of a well that will be removed following the installation of the permanent well casing and prior to or during placement of an annular seal. (3-18-22)()

563. Thermoplastic/PVC Casing. Plastic piping material meeting the requirements of ASTM F 480 and NSF-WC and specifically designed for use as well casing. (3-18-22)()

574. Transmissivity. The capacity of an aquifer to transmit water through its entire saturated thickness. (3-18-22)

585. Tremie Pipe. A small-diameter pipe used to convey grout, dry bentonite products, or filter pack materials into the annular space, borehole, or well from the bottom to the top of a borehole or well. (3-18-22)

596. Unconfined Aquifer. An aquifer in which the water table is in contact with and influenced by atmospheric pressure through pore spaces in the overlying formation(s). (3-18-22)

~~6057.~~ **Unconsolidated Formation.** A naturally-occurring earth formation that has not been lithified. Alluvium, soil, sand, gravel, clay, and overburden are some of the terms used to describe this type of formation. (3-18-22)

~~6158.~~ **Unstable Unit.** Unconsolidated formations, and those portions of consolidated formations, that are not sufficiently hard or durable enough to sustain an open borehole without caving or producing obstructions without the aid of fluid hydraulics or other means of chemical or physical stabilization. (3-18-22)

~~6259.~~ **Unusable Well.** Any well that can not be used for its intended purpose or other beneficial use authorized by law. (3-18-22)

630. Waiver. Approval in writing by the Director of a written request from the well driller and the well owner proposing specific variance from the minimum well construction standards. (3-18-22)

641. Waste. The loss, transfer, or subsurface exchange of a ground water resource, thermal characteristic, or natural artesian pressure from any aquifer caused by improper construction, misuse, or failure to properly maintain a well. Waste includes: (3-18-22)

a. The flow of water from an aquifer into an unsaturated subsurface zone; (3-18-22)

b. The transfer or mixing, or both, of waters from one aquifer to another (aquifer commingling); or (3-18-22)

c. The release of ground water to the land surface whenever such release does not comply with an authorized beneficial use. (3-18-22)

652. Water Table. ~~The height at which water will rise in a well; also t~~ IThe upper surface of the zone of saturation in an unconfined aquifer. This level will change over time due to changes in water supply and aquifer

impacts. (3-18-22)()

663. Well. (3-18-22)

~~a.~~ An artificial excavation or opening in the ground more than eighteen (18) feet in vertical depth below land surface by which ground water of any temperature is sought or obtained. ~~The depth of a well is determined by measuring the maximum vertical distance between the land surface and the deepest portion of the well.~~ Any water encountered in the well is considered to be obtained for the purpose of these rules; ~~or.~~ (3-18-22)()

~~b.~~ Any waste disposal and injection well, as defined in Section 42-3902, Idaho Code. (3-18-22)

~~e.~~ Well does not mean: (3-18-22)

~~i.~~ A hole drilled for mineral exploration; ~~or~~ (3-18-22)

~~ii.~~ Holes drilled for oil and gas exploration which are subject to the requirements of Section 47-320, Idaho Code; ~~or~~ (3-18-22)

~~iii.~~ Holes drilled for the purpose of collecting soil samples above the water table. (3-18-22)

674. Well Development. The act of bailing, jetting, pumping, or surging water in a well to remove drilling fluids, fines, and suspended materials from within a completed well and production zone ~~in order~~ to establish the optimal hydraulic connection between the well and the aquifer. (3-18-22)()

685. Well Driller or Driller. Any person who operates drilling equipment, or who controls or supervises the construction of a well, and is licensed under Section 42-238, Idaho Code (3-18-22)

696. Well Drilling or Drilling. The act of constructing a new well or modifying ~~or changing~~ the construction of an existing well. (3-18-22)()

~~7067.~~ **Well Owner.** Any person, firm, partnership, co-partnership, corporation, association, or other entity, or any combination of these, who owns the property on which the well is or will be located or has secured ownership of the well by means of a deed, covenant, contract, easement, or other enforceable legal instrument for the purpose of benefiting from the well. (3-18-22)

~~7168.~~ **Well Rig (Drill Rig).** Any power driven percussion, rotary, boring, digging, jetting, ~~or~~ auguring, ~~machine used in the construction or any other power-driven mechanical equipment used in the drilling~~ of a well. (3-18-22)()

011. -- 024. (RESERVED)

025. CONSTRUCTION OF ~~COLD GROUND~~ WATER WELLS (RULE 25).

All persons constructing wells must comply with the requirements of Section 42-238, Idaho Code, and IDAPA 37.03.10, "Well Driller Licensing Rules." The standards specified in Rule 25 apply to all wells, including waste disposal and injection wells as defined in Section 42-3902, Idaho Code, with a bottom hole temperature of eighty-five (85) degrees Fahrenheit or less than two hundred twelve (212) degrees Fahrenheit. Wells with a bottom hole temperature greater than eighty-five (85) degrees Fahrenheit, but less than two hundred twelve (212) degrees Fahrenheit, must meet also the requirements of Rule 30 in addition to meeting the requirements of Rule 25. These standards also apply to any waste disposal and injection well as defined in Section 42-3902, Idaho Code. (3-18-22)()

01. General. The well driller must construct each well as follows: (3-18-22)

a. In accordance with these rules and with the conditions of approval of any drilling permit issued pursuant to Section 42-235, Idaho Code, and in a manner that will prevent waste and contamination of the ground water resources of the state of Idaho. The adopted standards are minimum standards which must be adhered to in the construction of all new wells, and in the modification or decommissioning ~~(abandonment)~~ of existing wells. The well

driller is charged with the responsibility of preventing waste ~~or~~ and contamination of the ground water resources during the construction, modification or abandonment of a well. The Director may add conditions of approval to a drilling permit issued pursuant to Rule 45 of these rules to require that a well be constructed, modified, maintained or decommissioned ~~(abandoned)~~ in accordance with additional standards when necessary to protect ground water resources and the public health and safety from ~~existing~~ contamination and waste ~~or contamination~~ during the construction, modification or decommissioning ~~(abandonment)~~ of a well. (3-18-22)()

b. In consideration of the geologic and ground water conditions known to exist or anticipated at the well site. (3-18-22)

c. Such that it is capable of producing, where obtainable, the quantity of water to support the allowed or approved beneficial use of the well, subject to law. (3-18-22)()

d. Meet the siting and separation distance requirements in the table in this Subsection (025.01.d.). Additional siting and separation distance requirements are set forth by the governing district health department and the Idaho Department of Environmental Quality rules at IDAPA 58.01.03, "Individual/Subsurface Sewage Disposal Rules," and IDAPA 58.01.08, "Idaho Rules for Public Drinking Water Systems".

Separation of Well from:	Minimum Separation Distance (feet)
Existing Public Water Supply well, separate ownership	- 50
Other existing well, separate ownership	- 25
Septic drain field	- 100
Septic tank	- 50
Drainfield of system with more than 2,500 GPD of sewage inflow	- 300*
Sewer line - main line or sub-main, pressurized, from multiple sources	- 100
Sewer line - main line or sub-main, gravity, from multiple sources	- 50
Sewer line - secondary, pressure tested, from a single residence or building	- 25
Effluent pipe	- 50
Property line	- 5
Permanent buildings, other than those to house the well or plumbing apparatus, or both	- 10
Above ground chemical storage tanks	- 20
Permanent (more than six months) or intermittent (more than two months) surface water	- 50
Canals, irrigation ditches or laterals, & other temporary (less than two months) surface water	- 25
*This distance may be less if data from a site investigation demonstrates compliance with IDAPA 58.01.03, "Individual/Subsurface Sewage Disposal Rules," separation distances.	

(3-18-22)

02. Waivers. In unique cases where the Director concludes that the ground water resources will be protected against waste and contamination and the public health and safety are not compromised, a waiver of specific standards required by these rules may be approved prior to constructing, decommissioning, or modifying a well. The Director may request comments from IDEQ or local Health Districts when considering waivers seeking a variance of separation distances established by IDEQ Rules, which includes separation distances between wells and septic tanks, wells and septic drain fields, wells and sewer lines, or wells and effluent pipes. (3-18-22)()

- a. To request a waiver the well driller and well owner must: (3-18-22)
- i. Jointly submit a detailed plan and written request identifying a specific Rule or Rules proposed to be waived. Additionally, the plan must detail the well construction process that will be employed in lieu of complete Rule compliance: (3-18-22)
- ii. Prior to submittal, the well driller and the well owner must sign the plan and written request acknowledging concurrence with the request; and (3-18-22)
- iii. Submit the plan and request by facsimile, e-mail, or letter. (3-18-22)
- b. The Director will evaluate and respond to the request within ten (10) business days of receiving the request. (3-18-22)
- i. If the request for waiver is approved, the intent of the rules will be served, and all standards not waived will apply. Waivers approved by the Director will not supersede the requirements of other regulatory agencies without specific concurrence from that agency. Work activity related to a waiver request will not proceed until a written or verbal approval is granted by the Director. (3-18-22)()
- ii. Any verbal approval will be followed by a written approval. (3-18-22)

03. Records. ~~In order to~~ To enable a comprehensive survey of the extent and occurrence of the state's ground water resource, the coordinates of every newly constructed, modified or decommissioned ~~(abandoned)~~ well location must be identified by latitude and longitude with a global positioning system (GPS) and recorded on the driller's report in degrees and decimal minutes and within the nearest 40 acre parcel using the Public Land Survey System. Every well driller must maintain records as described in IDAPA 37.03.10 "Well Driller Licensing Rules," pursuant to Section 42-238(11), Idaho Code, and provide the well owner with a copy of the approved well drilling permit and a copy of the well driller's report when submitted to the Director. (3-18-22)()

04. Casing. The well driller must install casing in every well. Steel ~~or thermoplastic~~ casing may be installed in any well, thermoplastic casing may be installed in a well with a bottom hole temperature of eighty-five (85) degrees Fahrenheit or less if drilling of the borehole confirms its suitability for use. ~~Thermoplastic pipe must not be installed in a well with a bottom hole temperature greater than eighty-five (85) degrees Fahrenheit.~~ All casing to be installed must be new or in like-new condition, free of defects, and clearly marked by the manufacturer with all specifications required by these rules. For all wells the casing must extend at least twelve (12) inches above land surface and finished grade and to a minimum depth below land surface as required by these rules. Concrete slabs around a well casing will be considered finished grade (Figure 01, Appendix A). The well driller must install casing of sufficient strength to withstand calculated and anticipated subsurface forces and corrosive effects. The well driller must install casings sufficiently plumb and straight to allow the installation or removal of screens, liners, pumps and pump columns without causing adverse effects on the operation of the installed pumping equipment. (3-18-22)()

- a. Steel Casing. When steel casing lengths are joined together, they joints must be joined by welded joints or screw-couple joints and be watertight. ~~All connection must be water tight. If steel casing Welded joints are welded, the weld~~ must be at least as thick as the well casing and fully penetrating. Welding rods or flux core wire of at least equal quality to the casing metal must be used. Casing ends to be joined by welding must be properly prepared, beveled and gapped to allow full penetration of the weld. All stick welded joints must have a minimum of two (2) passes including a "root" pass and have minimal undercut when complete. (3-18-22)()
- i. In addition to meeting these standards, all wells that are constructed for public drinking water systems must meet ~~all of the~~ casing wall thickness requirements set forth by the Idaho Department of Environmental Quality Rules, IDAPA 58.01.08, "Idaho Rules for Public Drinking Water Systems." (3-18-22)()
- ii. The well driller must install steel casing that meets or exceeds the American Society of Testing and Materials (ASTM) standard A53, Grade B or American Petroleum Institute (API) 5L Grade B, and that meets the following specifications for wall thickness:

Minimum Single-Wall Steel Well Casing Thickness ¹ for Selected Diameters (inches)													
Nominal Diameter (in.) ³	6 ²	8	10	12	14	16	18	20	22	24	26	28	30
Depth (ft.)	Nominal Wall Thickness (in.) ¹												
<100	0.250	0.250	0.250	0.250	0.250	0.250	0.250	0.250	0.250	0.250	0.250	0.250	0.250
100-200	0.250	0.250	0.250	0.250	0.250	0.250	0.250	0.250	0.250	0.250	0.250	0.250	0.250
200-300	0.250	0.250	0.250	0.250	0.250	0.250	0.250	0.250	0.250	0.250	0.250	0.250	0.250
300-400	0.250	0.250	0.250	0.250	0.250	0.250	0.250	0.250	0.250	0.375	0.375	0.375	0.375
400-600	0.250	0.250	0.250	0.250	0.250	0.250	0.250	0.250	0.375	0.375	0.375	0.375	0.375
600-800	0.250	0.250	0.250	0.250	0.250	0.250	0.375	0.375	0.375	0.375	0.375	0.375	0.375
800-1000	0.250	0.250	0.250	0.250	0.375	0.375	0.375	0.375	0.375	0.375	0.375	0.375	0.375
1000-1500	0.280	0.322	0.365	0.375	0.375	0.375	0.375	0.375	0.375	0.375	0.375	0.375	0.375
1500-2000	0.280	0.322	0.365	0.375	0.375	0.375	0.375	0.375	0.375	0.375	0.375	0.375	0.375
<p>1 Compliance with the minimum nominal wall thicknesses listed is required for any depth or location where casing is used to prevent caving or collapse, or both, of the borehole or serves as a solid inner barrier to allow for the installation of an annular seal.</p> <p>2 For nominal casing diameters less than six (6) inches, the minimum nominal wall thickness must be equivalent to ASTM Schedule 40.</p> <p>3 For any other casing diameter not addressed herein, prior approval by the Director is required.</p>													

(3-18-22)

b. Thermoplastic Casing. ~~Thermoplastic casing may be used in monitoring wells and cold water wells if drilling of the borehole confirms its suitability for use.~~ (3-18-22)

i. ~~Thermoplastic casing must conform to ASTM F 480 and NSF-WC, have a minimum rating of SDR-21 or a minimum rating of Schedule 40 for nominal diameters of four (4) inches or less.~~ The well driller must not use thermoplastic casing under any condition where the manufacturer's resistance to hydraulic collapse pressure (RHCP) or total depth specifications are exceeded. Thermoplastic casing extending above-ground must be protected from physical and ultraviolet light damage by enclosing it within steel casing extending at least twelve (12) inches above land surface and finished grade and to a minimum depth of eighteen (18) feet below land surface or five (5) feet below land surface for monitoring wells. (3-18-22)()

ii. ~~Thermoplastic pipe used in wells as casing or liner must have a minimum rating of SDR-21. For nominal diameters of four (4) inches or less, a minimum rating of Schedule 40 is required.~~ If used as casing within unconsolidated or unstable consolidated formations, thermoplastic pipe must be centralized and fully supported throughout the unstable zone(s) with filter pack or seal material as required by these rules. (3-18-22)()

iii. All thermoplastic casing ~~and liner~~ must be installed in accordance with the manufacturer's recommendations and specifications, and as required by these rules. The well driller will not treat thermoplastic pipe in any manner that would adversely affect its structural integrity. The well driller must: (3-18-22)()

(1) Ensure that the weight of the pump assembly, if secured to the thermoplastic pipe, does not exceed the weight limitations per manufacturer's recommendations or cause damage to the pipe resulting in breaks or leaks. (3-18-22)

(2) Not use Type III (high-early strength) Portland cement-based seal materials in direct contact with thermoplastic pipe unless approved by the Director. (3-18-22)

(3) Not drive, drop, force, or jack thermoplastic pipe into place. Thermoplastic pipe must be lowered or floated into an oversized, obstruction-free borehole. (3-18-22)

c. Perforated Well Casing. Perforated well casing may be used in the construction or decommissioning of a well when such application does not violate any standards required by these rules. (3-18-22)

05 Liner. ~~In addition to well casing, liners may be installed in wells +~~ To prevent damage to pumping equipment, ~~Steel or thermoplastic pipe~~ meeting the specifications and conditions for use as casing may be installed as liner ~~in a well with a bottom hole temperature of eighty five (85) degrees Fahrenheit or less. Thermoplastic liner must conform to ASTM F 480 and NSF WC.~~ Thermoplastic liners must not be used in unconsolidated formations or unstable units. (3-18-22)()

06. Screen. Well screens must be used in constructing a well when necessary to avoid sand production (see sand production, Rule 25, Subsection 025.24). Well screens must be commercially manufactured, be slotted, louvered or wire wrapped, and be installed ~~according to~~ the manufacturers specifications. (3-18-22)()

a. Screens may require a filter pack consisting of sand or gravel to further reduce the quantity of sand produced from the well. (3-18-22)

b. The well driller will not install well screens, perforated casing or filter pack across a confining layer(s) separating aquifers of different pressure, temperature, or quality. (3-18-22)

07. Use of Approved Sealing Materials and Required Annular Space. Well casings must be sealed in the required annular space with approved material to prevent the possible downward movement of ~~contaminated~~ surface waters or other fluids in any annular space around the well casing (Figure 02, Appendix A). Proper sealing is also required to prevent the movement of groundwater either upward or downward from zones of different pressure, temperature or quality within the well or outside the casing. The well driller must notify by phone the Department's appropriate Region Office at least four (4) hours in advance of placing any annular seal to provide Department staff the opportunity to observe seal placement. (3-18-22)()

a. All casing to be sealed must be adequately centralized to ensure uniform seal thickness around the well casing. Surface seals must extend to not less than thirty-eight (38) feet below land surface for well depths greater than thirty-eight (38) feet. For well depths less than thirty-eight (38) feet, seals must extend to depths as hereafter required. (3-18-22)

b. Seals are required at depths greater than thirty-eight (38) feet in artesian wells or to seal through confining layers separating aquifers of differing pressure, temperature, or quality in any well. (3-18-22)

c. When a well is modified and the existing casing is moved or the original seal is damaged, or a well driller discovers that a seal was not installed or has been damaged, the well driller must repair, replace, or install a seal around the permanent casing that is equal to or better than required when the well was originally constructed. (3-18-22)

d. Manufactured packers ~~and~~ shale traps, and cementing baskets may be used as devices to retain approved seal material when installing a required annular seal. Whenever these devices are used to retain seal material, the well driller must comply with the manufacturer's recommendations for installation. (3-18-22)()

e. If a temporary casing has been installed, upon completion of the drilling, the annular space must be filled with approved seal material and kept full while withdrawing the temporary casing. Bentonite chips should be used with caution when the annular space between a temporary casing and permanent casing is filled with water. (3-18-22)

i. When attempts at removing a temporary casing are unsuccessful, the casing must be sealed in place by a method approved by the department. (3-18-22)

ii. The well driller must notify the department whenever a temporary casing can not be removed and propose a plan to adequately seal the casing to prevent waste and contamination of the ground water. The plan must detail how the casing will be sealed on the outside to a sufficient depth below land surface in addition to placement of any required formation seals through the interval at which the casing will remain. (3-18-22)

f. For mixed grout seals the minimum annular space required must provide for a uniform seal thickness not less than one (1) inch on all sides of the casing or a borehole at least two (2) inches larger than the outside diameter (OD) of the casing to be sealed (Figure 02, Appendix A). (Note: a seven and seven-eighths (7 7/8) inch diameter (eight (8) inch nominal) borehole around a six and five-eighths (6 5/8) inch OD (six (6) inch nominal casing does not satisfy the minimum annular space requirements). (3-18-22)

i. When placing grout seals with a removable tremie pipe between casing strings or between a borehole and casing, the required annular space must be ~~at least~~ one (1) inch or equal to the OD of the tremie pipe, whichever is greater. Permanent tremie pipes will be considered as a casing string and subject to minimum annular space requirements in addition to the annular space requirements around the well casing (Figure 03, Appendix A). (3-18-22)()

ii. All grout seals must be placed from the bottom up, by using an approved method. Bentonite grout must not be used above the water table unless specifically designed and manufactured for such use and approved by the Director in advance. (3-18-22)

iii. If cement-based grout (neat cement or neat cement grout) is used to create a seal, the casing string sealed must not be moved or driven after the initial set. Construction must not resume for a minimum of twenty-four (24) hours following seal placement; (3-18-22)

g. For dry bentonite seals the minimum annular space required must provide for a uniform seal thickness not less than one and five-eighths (1 5/8) inches on all sides of the casing or a borehole at least four (4) inches larger than the “nominal diameter” of the casing to be sealed. e.g., (six and five-eighths (6 5/8) inch OD (six (6) inch nominal) casing requires a ten and three fourths (10 3/4) inch OD (ten (10) inch nominal) temporary casing or a nine and seven-eighths (9 7/8) inch (ten (10) inch nominal) minimum borehole). Listed below are additional annular space requirements and limitations for placement of dry bentonite seals: (3-18-22)

i. All dry bentonite seals must be tagged during placement and consider volumetric calculations to verify placement. (3-18-22)

ii. Installation of dry bentonite seals must be consistent with the manufacturers’ recommendations and specifications for application and placement. (3-18-22)

iii. Granular bentonite must not be placed through water. (3-18-22)

iv. If a granular bentonite seal is placed deeper than two hundred (200) feet, the minimum annular space must be increased by at least one (1) inch e.g., (six and five-eighths (6 5/8) inch OD (six (6) inch nominal) casing requires a twelve and three fourths (12 3/4) inch OD (twelve (12) inch nominal) temporary casing or an eleven and seven eighths (11 7/8) inch (twelve (12) inch nominal) minimum borehole). (3-18-22)

v. Bentonite chips and pellets may be placed through water or drilling fluid of appropriate viscosity. Bentonite chip seals placed through more than fifty (50) feet of water or drilling fluid will require the minimum annular space to be increased by at least one (1) inch e.g., (six and five-eighths (6 5/8) inch OD (six (6) inch nominal) casing requires a twelve and three fourths (12 3/4) inch OD (twelve (12) inch nominal) temporary casing or an eleven and seven eighths (11 7/8) inch (twelve (12) inch nominal) minimum borehole). (3-18-22)()

08. Sealing of Wells. Sealing requirements described herein are minimum standards that apply to all wells. The Director may establish alternate minimum sealing requirements in specific areas when it can be determined through detailed studies of the local hydrogeology that a specific alternate minimum will provide protection of the ground water from waste and contamination. (3-18-22)

a. Consolidated Formations. When a ~~water~~ well encounters consolidated formations above the water table and is drilled into and constructed to acquire water from an unconfined aquifer ~~that consists of in the consolidated formations that are above the water table~~, casing must be installed so that it extends and is sealed to a depth not less than thirty-eight (38) feet (Figure 04, Appendix A). If the well depth is less than thirty-eight (38) feet from land surface, well casing must be installed and sealed five (5) feet into the consolidated formation or to a depth of eighteen (18) feet, whichever is greater. (3-18-22)()

b. Unconsolidated Formations without Confining Layers of Clay. When a ~~water~~ well encounters unconsolidated formations above the water table and is drilled into and constructed to acquire water from an unconfined aquifer ~~that is overlain with in the unconsolidated formations, such as sand and gravel without confining layers of clay, well~~ casing must extend to at least five (5) feet below the water table and be sealed to a depth not less than thirty-eight (38) feet (Figure 05, Appendix A). If the well depth is less than thirty-eight (38) feet well casing must extend to at least five (5) feet below the water table or eighteen (18) feet, whichever is greater, and be sealed to a depth of at least eighteen (18) feet. (3-18-22)()

i. The extensive (for example, one hundred fifty (150) feet thick or more) unconsolidated, non-stratified, sand and gravel of the Rathdrum Prairie are characterized by extremely high transmissivity and hydraulic conductivity. Under these conditions, sealing wells to depths greater than eighteen (18) feet may not be additionally protective. When a water well is drilled within the boundaries of the Rathdrum Prairie, (shown in Figure 06, Appendix A of these rules), ~~well~~ casing must extend to at least five (5) feet below the water table and be sealed to a depth not less than eighteen (18) feet (Figure 07, Appendix A). (3-18-22)()

c. Unconsolidated Formations with Confining Layers of Clay. When a well is drilled into and acquires water from an aquifer that is overlain by unconsolidated deposits such as sand and gravel, and there are confining layers ~~of clay~~ above the water table, well casing must be installed from the land surface to the confining layer immediately above and in contact with the production zone and sealed to a depth not less than thirty-eight (38) feet (Figure 08, Appendix A). If the well depth is less than thirty-eight (38) feet from land surface, well casing must extend and be sealed into the first confining layer or to a depth of eighteen (18) feet, whichever is greater. (3-18-22)()

09. Sealing Artesian Wells. (3-18-22)

a. Unconsolidated Formations. When artesian water is encountered in unconsolidated formations, the production zone or open interval must be limited to zones of like pressure, temperature, and quality. Water encountered in oxidized sediments must not be comingled with water encountered in reduced sediments. Well casing must extend from land surface into the lower most confining layer above the production zone, and must be sealed: (3-18-22)

i. From land surface to a depth of at least thirty-eight (38) feet; and (3-18-22)

ii. Through all confining layer(s); and (3-18-22)

(1) A minimum of five (5) feet of seal material must be placed into or through the lower most confining layer above the production zone (Figure 09, Appendix A); or (3-18-22)

(2) Five (5) feet into or through the lowermost confining layer above the production zone and continuously to land surface (Figure 09, Appendix A). (3-18-22)

iii. If the well depth is less than thirty-eight (38) feet, the well must be cased and sealed from land surface to the confining layer in direct contact with the production zone or to a depth of eighteen (18) feet, whichever is greater. (3-18-22)

b. Consolidated Formations. When artesian water is encountered in a consolidated formation, well casing must be installed and sealed from land surface to a depth of at least thirty-eight (38) feet; and (3-18-22)

i. If the consolidated formation is overlain by a permeable formation(s) and water will rise above the consolidated formation, well casing must extend and be sealed at least five (5) feet into the confining portion of the

consolidated formation (Figure 10, Appendix A). (3-18-22)

ii. If the well depth is less than thirty-eight (38) feet, the well must be cased and sealed from land surface five (5) feet into the confining consolidated formation or to a depth of eighteen (18) feet, whichever is greater. (3-18-22)

c. Control Device. Pursuant to Section 42-1603, Idaho Code, if the well flows at land surface, it must be equipped with a control device approved by the Director, so that the flow can be completely stopped. If leaks occur around the well casing or adjacent to the well, the well leakage must be ~~completed~~ **eliminated to the extent possible** with **approved** seals, casing, or ~~cement grout to eliminate the leakage~~ **other means approved by the Director.** (3-18-22)()

i. Flowing artesian wells must be equipped with an approved pressure gage fitting that will allow access for measurement of shut-in pressure of a flowing well. All pressure gage fittings must include control valves such that the pressure gage can be removed without resulting in artesian flow from the well. (3-18-22)

ii. The well driller must not move his well drilling rig from the site until all requirements have been satisfied. Some mixing of water may be allowed to develop an adequate water well; however, the mixing must be restricted to water zones of similar pressure, temperature and quality. The driller must take precautions to case and seal out zones which may lead to waste or contamination. (3-18-22)

10. Alternative Methods for Sealing Wells. To accommodate ~~for~~ new technology, and in consideration of the wide variety of drilling equipment used to construct wells, other methods of sealing wells not specifically addressed in these rules may be allowed. The Director may consider specific proposals for alternative methods of sealing on a case by case basis. Director approval or acceptance of such procedures will not constitute a “waiver” of any requirements of these rules. In such cases, the well driller must provide sufficient information for the Director to determine that the full intent of the sealing requirements will be satisfied if an alternative method is employed. If it is determined that a specific alternate method will provide protection of the ground water from waste and contamination, the Director may issue a statement of acceptance qualifying the use and implementation of such methods. (3-18-22)()

11. Injection Wells. In addition to meeting the requirements of Rule 25 of these rules, the construction, modification, or decommissioning ~~(abandonment)~~ of all injection wells over eighteen (18) feet in vertical depth must also comply with the IDAPA 37.03.03, “Rules for the Construction and Use of Injection Wells,” and the injection well permit. Drillers must obtain from the Director a certified copy of the permit authorizing construction or modification of an injection well before beginning work. (3-18-22)()

12. Cathodic Protection Wells. All cathodic protection wells must be constructed by a licensed well driller in compliance with these rules. A detailed construction plan must be included with the drilling permit application. (3-18-22)

13. Monitoring and Remediation Wells. All monitoring wells and remediation wells must be constructed and maintained in a manner that will prevent waste or contamination and as otherwise required by these rules. When a monitoring well or a remediation well is no longer useful or needed, the owner or operator of the well must decommission ~~(abandon)~~ the well in accordance with Rule 25, Subsection 025.16 of these rules. No person may divert ground water from a monitoring well or a remediation well for any purpose not authorized by the Director. The application for a permit for all monitoring wells and all remediation wells must include a design proposal prepared by a licensed engineer or registered geologist pursuant to Section 42-235, Idaho Code. Blanket permits for monitoring well and remediation well networks may be approved for site-specific monitoring and remediation programs. The designs and specification for monitoring wells and remediation wells must demonstrate that: (3-18-22)()

a. The ground water resources are protected against waste and contamination; (3-18-22)

b. The well(s) will inject or withdraw only fluids, gases or solutions approved by the Director; (3-18-22)

c. The well(s) will be constructed ~~so as~~ to prevent aquifer commingling; and (3-18-22)()

d. The well(s) will be properly decommissioned—~~(abandoned)~~ upon project completion and in accordance with these rules. (3-18-22)()

14. Closed Loop Heat Exchange Wells. The well driller must construct closed loop heat exchange wells consistent with these rules. The well driller is not required to install steel casing in such wells. When constructing a closed loop heat exchange well, the well driller must: (3-18-22)

- a. Construct each borehole of sufficient size to provide the annular space required by these rules. (3-18-22)
- b. Seal the annular space of each borehole with approved seal material in accordance with these rules; (3-18-22)
- c. Install fluid-tight circulating pipe, composed of high-density polyethylene, grade PE3408, minimum cell classifications PE355434C or PE345434C conforming to ASTM Standard D3350, or another Director-approved pipe; (3-18-22)()
- d. Join pipe using thermal fusion techniques according to ASTM Standards D-3261 or D-2683. All personnel creating such system joints must be trained in the appropriate thermal fusion technologies; (3-18-22)
- e. Use only propylene glycol, or other circulating fluid approved by the Director; (3-18-22)
- f. Ensure that any other system additive is NSF approved and has prior approval from the Director; (3-18-22)
- g. Pressure test each loop with potable water prior to grout installation; (3-18-22)
- h. Pressure test the system with potable water prior to installation of the circulating fluid at one hundred percent (100%) of the designed system operating pressure for a minimum duration of twenty-four (24) hours; and (3-18-22)
- i. Properly repair or decommission—~~(abandon)~~ all loops failing the test by pressure pumping approved seal material through the entire length of each failed loop. After grouting, loop ends must be fused together or capped. (3-18-22)()

15. Access Port or Pressure Gage. Upon completion—~~of a well and before removal of the well rig from the site,~~ the well must be equipped with an access port that will allow for measurement of the depth to water or an approved pressure gage fitting that will allow access for measurement of shut-in pressure of an artesian flowing well. All pressure gage fittings must include control valves such that the pressure gage can be removed. Approved access ports are illustrated in Figures 1 and 11, APPENDIX A, together with approved locations for pressure gage fittings. Air lines are not a satisfactory substitution for an access port. Nonflowing domestic and stock water wells that are to be equipped with a sanitary seal with a built-in access port are exempt from this requirement. (3-18-22)()

16. Decommissioning—~~(Abandoning)~~ of Wells. (3-18-22)

a. The well owner is charged with maintaining and properly decommissioning—~~(abandoning)~~ a well in a manner that will prevent waste or contamination, or both, of the ground water. No person is allowed to decommission a well in Idaho without first obtaining a driller's license or receiving a waiver of the license requirement from the Director of the Department of Water Resources. Authorization is required from the Director prior to decommissioning any well. Upon decommissioning, the person who decommissioned the well must submit to the Director a report describing the procedure. (3-18-22)()

b. The Director may require decommissioning of a well in compliance with the provisions of these rules, if the well: (3-18-22)

- i. Does not meet minimum well construction standards; (3-18-22)

- ii. Meets the definition of an unusable well; (3-18-22)
 - iii. Poses a threat to human health and safety; (3-18-22)
 - iv. Is in violation of IDAPA 58.01.11, “Ground Water Quality Rule”; or (3-18-22)
 - v. Has no valid water right or other authorization acceptable to the Director for use of the well. (3-18-22)
 - c. When required by the Director, decommissioning must be done in accordance with the following: (3-18-22)
 - i. Cased wells and boreholes without a continuous seal from the top of the intakes or screen to the surface. The well driller must use one (1) of the following methods as applicable: (3-18-22)
 - (1) The Director may require that well casing be perforated every five (5) feet from the bottom of the casing to within five (5) feet of the surface. Perforations made must be adequate to allow the free flow of seal material into any voids outside the well casing. There must be at least four equally spaced perforations per section circumference. Approved grout must be pressure pumped to fill any voids outside of the casing. A sufficient volume must be used to completely fill the well and annular space; or (3-18-22)
 - (2) Fill the borehole with approved seal material as the casing is being removed. (3-18-22)
 - ii. Cased wells and boreholes with full-depth seals. If the well is cased and sealed from the top of the screen or production zone to the land surface, the well must be ~~completely~~ filled with approved seal material. (3-18-22)()
 - iii. Uncased wells must be ~~completely~~ filled with approved seal material. (3-18-22)()
 - iv. Dry hole wells or wells from which the quantity of water to meet a beneficial use cannot be obtained must be decommissioned with ~~cement grout, concrete or other~~ approved seal material in accordance with these rules. (3-18-22)()
- 17. Completion of a Well.** The Director will consider that every well is completed when the well drilling equipment has been removed, unless written notice has been given to the Director by the well driller that he intends to return and do additional work on the well within a specified period ~~of time~~. Upon completion of the well, the well must meet all ~~of the~~ required standards. (3-18-22)()
- a. Upon completion of drilling and prior to removal of well drilling equipment from a water well site, the top of the casing must be completely covered with: (3-18-22)
 - i. A one-fourth inch (1/4”) thick solid, new or like-new steel plate with a three-fourths inch (3/4) threaded and plugged access port, welded to and completely covering the casing (Figure 12, Appendix A); or (3-18-22)
 - ii. A threaded cap, or a commercially manufactured watertight sanitary well cap (Figure 12, Appendix A); or (3-18-22)
 - iii. A commercially manufactured water-tight, snorkel-vented or non-vented well cap on any well susceptible to submergence; or (3-18-22)
 - iv. A control device approved by the Director per Section 42-1603, Idaho Code, on any well that flows at land surface (Figure 11, Appendix A). (3-18-22)
 - b. Upon the completion of every well, the well driller must permanently affix the stainless steel well tag to the steel ~~surface~~ casing in a manner and location that maintains tag legibility. For closed loop heat exchange

wells, the well driller must obtain approval for the well tag placement and method of attachment. The well driller must secure each tag by: (3-18-22)()

- i. A full-length weld across the top and down each side of the tag; or (3-18-22)
- ii. Using one (1) stainless steel, closed-end domed rivet near each of the four (4) corners of the tag. (3-18-22)
- iii. Prior to welding or riveting, the tag must be pre-shaped to fit the casing such that both sides to be welded or riveted touch the casing and no gaps exist between the tag and casing. (3-18-22)

18. Pitless Adapters. When a pitless adaptor is used (Figure 12, Appendix A), the adaptor should be of the type approved by the NSF International testing laboratory or the approval code adopted by the Pitless Adaptor Division of the Water Systems Council. The pitless adaptor, including the cap or cover, casing extension, and other attachments, must be so designed and constructed to be water tight and to prevent contamination of the potable water supply from external sources. If a permanent surface or outer casing is installed and is cut off or breached to install the pitless adapter on an inner well casing or liner, the space between the permanent outer casing and the liner or inner casing must be sealed. The well owner or person installing the pitless adaptor must then seal the excavation surrounding the pitless adaptor using an approved seal material. (3-18-22)

19. Pump Installation. No person is allowed to install a pump into any well that would cause a violation of ~~Rule 25~~, of these rules or other applicable rules or state law. (3-18-22)()

20. Explosives. Explosives used in well construction must never be detonated inside the required well casing. Approved explosive casing perforators may be exempted by the Director. (3-18-22)

21. Hydraulic Fracturing. Hydraulic fracturing must be performed only by well drillers licensed in Idaho. The pressure must be transmitted through a drill string and must not be transmitted to the well casing. The driller must provide a report to the Director of the fracturing work which must include well location, fracturing depth, fracturing pressures and other data as requested by the Director. (3-18-22)

22. Drilling Fluids or Drilling Additives. The well driller must use only potable water and drilling fluids or drilling additives that are manufactured for use in water wells, are NSF International, American Petroleum Institute (API), or ASTM/ANSI approved; and do not contain a concentration of any substance in excess of Primary Drinking Water Standards, as set forth in IDAPA 58.01.08, “Rules for Public Drinking Water Systems,” according to manufacturer’s specifications. The well driller may seek approval from the Director to use specific, non-certified products on a case-by-case basis. In addition, the well driller must ensure the containment of all drilling fluids and materials used or produced to the immediate drilling site, and will not dispose of such fluids or materials into any streams, canals, boreholes, wells, or other subsurface pathways. (3-18-22)

23. Disinfection and Decontamination. Upon completion of a well, the driller is responsible for adding the appropriate amount of disinfecting chemical compound and distributing it throughout the well to achieve a uniform concentration for “in place” disinfection of the well. Chlorine compounds used in accordance with the table listed below will satisfy this requirement. Other methods may be used if approved by the Director in advance.

Amount of Chlorine Needed Per 100 Feet of Water in Well			
Casing Diameter (in.)	Gallons of water in casing per 100 ft. of water depth	Amount of 5.25% Sodium Hypochlorite (Unscented Laundry Bleach)	Amount of 65% Calcium Hypochlorite (Chlorine Granules)
6	147	2 ¼ cups	3 tbsp
8	261	4 cups	5 tbsp
10	408	6 ¼ cups	½ cup
12	588	9 cups	¾ cup

Amount of Chlorine Needed Per 100 Feet of Water in Well			
16	1044	1 gal	1 ¼ cup
Note: 1 gal = 4 qt = 8 pt = 16 cups; 1 cup = 16 tbsp			
Chlorine granules or tablets must be dissolved and placed into the well as a solution.			
If another concentration of hypochlorite solution is used, the following equation should be used for calculating amounts.			
(Volume of water in gallons) X (0.08) / % Hypochlorite (e.g. 50% = 50) = cups of hypochlorite			
Example: To treat 147 gallons of water using a 50% concentration of hypochlorite solution: (147 gallons water) X (0.08) / 50 = .23 (or approximately 1/4) cup of 50% Hypochlorite solution			

(3-18-22)

24. Sand Production. The maximum sand content produced from a well after initial well development must not exceed fifteen (15) ppm. ~~For the purpose of this rule, sand is considered to be~~ This rule applies to any sediment particle retained on a U.S. standard sieve #200 (seventy-five hundredths (0.075) mm to two (2) mm). (3-18-22)()

- a. When necessary to mitigate sand production the well driller must: (3-18-22)
 - i. Construct each well with properly sized casing, screen(s) or perforated intake(s); and (3-18-22)
 - ii. Install properly sized filter pack(s); or (3-18-22)
 - iii. Install pre-packed well screens; or (3-18-22)
 - iv. Employ other methods approved by the Director. (3-18-22)

b. The Director may grant a waiver exempting a well producing water that exceeds the maximum sand content only if the well driller has met the requirements of Rule 25, Subsection 025.24.a. (3-18-22)

c. Sand production in public drinking water system wells. Wells used in connection with a public drinking water system have more stringent requirements. See IDAPA 58.01.08, “Idaho Rules for Public Water Systems.” (3-18-22)()

25. Well Development and Testing. For each well the well driller must measure and record the static (non-pumping) water level and the pumping water level, and the production rate. The production rate will be determined by a pump, bailer, air-lift, or other industry approved test of sufficient duration to establish production from the well. For wells with no returns the driller must report no returns and the static water level. ~~This information must be documented on the well driller’s report~~ The well driller’s report must document this information. (3-18-22)()

026. -- 029. (RESERVED)

030. CONSTRUCTION OF LOW TEMPERATURE GEOTHERMAL RESOURCE WELLS AND BONDING (RULE 30).

01. General. Drillers constructing low temperature geothermal resource wells (bottom hole temperature more than eighty-five (85) degrees Fahrenheit and less than two hundred twelve (212) degrees Fahrenheit) must be qualified under the Well Driller Licensing Rules. All low temperature geothermal resource wells must be constructed in such a manner that the resource will be protected from waste due to lost artesian pressure and temperature. The owner or well driller is required to provide bottom hole temperature data, but the Director may

make the final determination of bottom hole temperature, based upon information available to him. (3-18-22)

a. All standards and guidelines for construction and decommissioning ~~(abandonment)~~ of cold water wells apply to low temperature geothermal resource wells except as modified by Rule 30, Subsections 030.03, 030.04, and 030.06. (3-18-22)()

b. ~~A~~ When low temperature geothermal resources are known or anticipated, a drilling prospectus must be submitted to and approved by the Director prior to the construction, modification, deepening or decommissioning ~~(abandonment)~~ of any low temperature geothermal resource well. The well owner and the well driller are responsible for the prospectus and subsequent well construction. (3-18-22)()

02. Well Owner Bonding. The owner of any low temperature geothermal resource well must file a surety bond or cash bond as required by Section 42-233, Idaho Code, with the Director in an amount not less than five thousand dollars (\$5,000) nor more than twenty thousand dollars (\$20,000) payable to the Director prior to constructing, modifying or deepening the well after July 1, 1987. The bond amount will be determined by the Director within the following guidelines. The bond will be kept in force for one (1) year following completion of the well or until released in writing by the Director, whichever occurs first. (3-18-22)

a. ~~Any well less than three hundred (300) feet deep with a bottom hole temperature of less than one hundred twenty (120) degrees Fahrenheit and a shut in pressure of less than ten (10) pounds per square inch gage (psig) at land surface~~ The owner of an artesian low temperature geothermal resource well must maintain a bond of five thousand dollars (\$5,000). (3-18-22)()

b. The owner of ~~any well three hundred (300) feet to one thousand (1,000) feet deep with a bottom hole temperature of less than one hundred fifty (150) degrees Fahrenheit and a shut in pressure of less than fifty (50) psig~~ a low temperature geothermal resource well which flows at land surface must maintain a bond of ten thousand dollars (\$10,000). (3-18-22)()

c. The owner of ~~any~~ a flowing low temperature geothermal resource well ~~not covered by Rule 30, Subsections 030.02.a. and 030.02.b.~~ with a bottom hole temperature of 140 degrees Fahrenheit or more must maintain a bond of twenty thousand dollars (\$20,000). (3-18-22)()

d. The Director may decrease or increase the bonds required if it is shown to his satisfaction that well construction or other conditions merit an increase or decrease. (3-18-22)

e. The bond requirements of Section 42-233, Idaho Code, are applicable to wells authorized by water right permits or licenses having a priority date earlier than July 1, 1987, if the well authorized by the permit or license was not constructed prior to July 1, 1987, or if an existing well constructed within the terms of the permit or license is modified, deepened or enlarged on or after July 1, 1987. (3-18-22)()

03. Casing. Low temperature geothermal resource wells must be properly cased and sealed to protect from cooling by preventing intermingling with cold water aquifers. Casing may consist of several different casing strings (i.e. conductor pipe, surface casing, intermediate casing, production casing) provided drilling depth does not exceed ten times the depth of the last cemented casing. (3-18-22)()

a. Steel casing which meets or exceeds the minimum specifications for permanent steel casing of Rule 25, Subsection 025.04 must be installed in every well. The Director may require a more rigid standard for collapse and burst strength as depths or pressures may dictate. ~~Every~~ Low temperature geothermal resource wells ~~which drilled in areas where existing wells are known to~~ flows at land surface must have a minimum of forty (40) feet of conductor pipe set and ~~cemented~~ sealed its entire length to provide anchorage for well head control devices. (3-18-22)()

b. If artesian pressure is encountered, ~~C~~ casing must be installed from twelve (12) inches above land surface and be sealed with approved seal material into the overlying confining strata of the thermal aquifer. The casing schedule may consist of several different casing strings ~~(i.e. conductor pipe, surface casing, intermediate casing, production casing)~~ which may all extend to land surface or may be overlapped and sealed or packed to prevent fluid migration out of the casing at any depth (Figure 13, Appendix A). (3-18-22)()

i. ~~Low temperature geothermal resource wells less than one thousand (1,000) feet deep and which encounter a shut-in pressure of less than fifty (50) psig at land surface must have two (2) strings of casing set and cemented to land surface. Conductor pipe must be a minimum of forty (40) feet in length or ten percent (10%) of the total depth of the well whichever is greater. Surface casing must extend into the confining stratum overlying the aquifer.~~ (3-18-22)

ii. ~~Low temperature geothermal resource wells one thousand (1,000) feet or more in depth or which will likely encounter a shut-in pressure of fifty (50) psig or more at land surface require prior approval of the drilling plan by the Director and must have three strings of casing cemented their total length to land surface. Conductor pipe must be a minimum length of forty (40) feet. Surface casing must be a minimum of two hundred (200) feet in length or ten percent (10%) of the total depth of the well, whichever is greater. Intermediate casing must extend into the confining stratum overlying the aquifer.~~ (3-18-22)

e. ~~Subsection 030.03.b. may be waived if it can be demonstrated to the Director through the lithology, electrical logs, geophysical logs, injectivity tests or other data that formations encountered below the last casing string set, will neither accept nor yield fluids at anticipated pressure to the borehole.~~ (3-18-22)

~~dc. A nominal borehole size of two (2) inches in diameter larger than the Outside Diameter (O.D.) of the casing or casing coupler (whichever is larger) must be drilled. All casing designations must be by O.D. and wall thickness and must be shown to meet a given specification of the American Petroleum Institute, the American Society for Testing and Materials, the American Water Works Association or the American National Standards Institute. The last string of casing set during drilling operations must, at the Director's option, be flanged and capable of mounting a valve or blow out prevention equipment to control flows at the surface before drilling resumes.~~ (3-18-22)()

04. Sealing of Casing. ~~All casing must be sealed its entire length with e Cement or a cement grout mixture unless waived by the Director~~ is required for wells with a bottom hole temperature of greater than 140 degrees Fahrenheit. The All mixed grout seal material must be placed from the bottom ~~of the casing to land surface up~~ either through the casing or tubing or by use of a tremie pipe. ~~The e Cement or cement grout must be undisturbed for a minimum of twenty-four (24) hours or as needed to allow adequate curing.~~ (3-18-22)()

a. A caliper log may be run for determining the volume of ~~cement seal material~~ to be placed with an additional twenty-five (25%) percent on site ready for mixing. If a caliper log is not run, an additional one hundred (100%) percent of the calculated volume of ~~cement seal material~~ must be on site ready for placement. (3-18-22)()

b. When placing mixed grout seal material ~~If there is no return of cement or cement grout~~ at the surface after circulating all of the ~~cement~~ mixture on site, the Director will determine whether remedial work should be done to ~~insure~~ ensure no migration of fluids around the well bore. (3-18-22)()

c. The use of additives such as bentonite, accelerators, retarders, and lost circulation material must follow manufacturer's specifications. (3-18-22)

05. Blow Out Prevention Equipment. The Director may require the installation of gate valves or annular blow out prevention equipment to prevent the uncontrolled blow out of drilling mud and geothermal fluid. (3-18-22)

06. Repair of Wells. The well driller must submit a drilling prospectus to the Director for review and approval prior to the repair or modification of a low temperature geothermal resource well. (3-18-22)

07. Decommissioning (Abandoning) of Wells. Proper decommissioning ~~(abandonment)~~ of any low temperature geothermal resource well requires the following: (3-18-22)()

a. All ~~cement plugs~~ mixed grout seal material must be pumped into the hole through drill pipe or tubing. (3-18-22)()

b. All open annuli must be ~~completely~~ filled with ~~cement~~ approved seal material. (3-18-22)()

- c. A ~~cement plug~~ **Approved seal material** at least one hundred (100) feet in vertical depth must be placed straddling (fifty (50) feet above and fifty (50) feet below) the zone where the casing or well bore meets the upper boundary of each ground water aquifer. (3-18-22)()
- d. A minimum of one hundred (100) feet of ~~cement~~ **approved seal material** must be placed straddling each drive shoe or guide shoe on all casing including the bottom of the conductor pipe. (3-18-22)()
- e. A surface plug of ~~either cement grout or concrete~~ **approved seal material** must be placed from at least fifty (50) feet below the top of the casing to the top of the casing. (3-18-22)()
- f. A ~~cement plug~~ **Approved seal material** must extend at least fifty (50) feet above and fifty (50) feet below the top of any liner installed in the well. The Director may waive this rule upon a showing of good cause. (3-18-22)()
- g. Other decommissioning (~~abandonment~~) procedures may be approved by the Director if the owner or operator can demonstrate that the low temperature geothermal resource, ground waters, and other natural resources will be protected. (3-18-22)()
- h. Approval for decommissioning (~~abandonment~~) of any low temperature geothermal well must be in writing by the Director prior to the beginning of any decommissioning (~~abandonment~~) procedures. (3-18-22)()

031. -- 034. (RESERVED)

035. HEALTH STANDARDS (RULE 35).

01. Public Drinking Water System Wells. In addition to meeting these standards, all wells that are constructed for public supply of domestic water must meet all ~~of the~~ requirements set forth by the Idaho Department of Environmental Quality Rules, IDAPA 58.01.08, "Idaho Rules for Public Drinking Water Systems." (3-18-22)()

02. Special Standards for Construction of Wells When Mineralized or Contaminated Water Is Encountered. Any time in the construction of a well that mineralized or contaminated water is encountered, the well driller must take the appropriate steps necessary to prevent the poor quality waters from entering the well or moving up or down the annular space around the well casing. The method employed to case and seal out this water will be determined by the well driller, provided all other minimum standards are met. The well driller will take special precautions in the case of filter-packed wells to prevent water of inferior quality from moving vertically in the filter packed portions of the well. All actions taken will be clearly documented on the well driller's report. (3-18-22)

03. Distances From Contaminant Sources. All water wells constructed for domestic use must comply with minimum distances from septic tanks, drain fields, drainfield replacement area and other siting requirements as set forth in Rule 25, Subsection 025.01.d. (3-18-22)

036. OWNERS RESPONSIBILITIES FOR WELL USE AND MAINTENANCE (RULE 36).

After a well is completed the well owner is responsible for water quality testing, properly maintaining the well, and reporting problems with a well to the Director. All wells must be capped, covered and sealed such that debris cannot enter the well, persons or animals cannot fall into the well, and water cannot enter the well around the outside of the casing. Pursuant to Section 42-1603, Idaho Code, the owner of any artesian well that will flow at land surface is required to apply to the Director for approval of a flow control device. (3-18-22)

01. Use. The well owner must not operate any well in a manner that causes waste or contamination of the ground water resource. Failure to operate, maintain, knowingly allow the construction of any well in a manner that violates these rules, or failure to repair or properly decommission (~~abandon~~) any well as herein required will subject the well owner to civil penalties as provided by statute. (3-18-22)()

02. Maintenance. The well owner must: (3-18-22)

a. Not allow modification to wells under their control without first obtaining an approved Idaho Department of Water Resources (IDWR) permit, pursuant to Section 42-235, Idaho Code; (3-18-22)

b. Maintain the minimum casing height of twelve (12) inches above land surface and finished grade; (3-18-22)

c. Maintain the appropriate well cap, and control device if required, according to these Rules; and (3-18-22)

d. Not install or allow the installation of any well pump that would cause a violation of the sand production requirements in accordance with these Rules or allow the well to pump ~~in excess of~~ more than that allowed by a valid water right or domestic exemption. (3-18-22)()

e. Maintain the well to prevent waste or contamination of ground waters through leaky casings, pipes, fittings, valves, pumps, seals or through leakage around the outside of the casings, whether the leakage is above or below the land surface. Any person owning or controlling a non-compliant well must have the well repaired by a licensed well driller under a permit issued by the Director in accordance with these Rules. (3-18-22)

03. New Construction. The well owner must not construct or allow construction of any permanent building, except for buildings to house a well or plumbing apparatus, or both, closer than ten (10) feet from an existing well. (3-18-22)

04. Maintain All Other Separation Distances. The well owner must not construct or install, or allow the construction or installation of any object listed in a location closer than that allowed by the table of Rule 25, Subsection 025.01.d. (3-18-22)

05. Unusable Wells. The well owner must have any unusable well repaired or decommissioned (~~abandoned~~) by a licensed well driller under a permit issued by the Director in accordance with these Rules. (3-18-22)()

06. Wells Posing a Threat to Human Health and Safety or Causing Contamination of the Ground Water Resource. The well owner must have any well shown to pose a threat to human health and safety or cause contamination of the ground water resource immediately repaired or decommissioned (~~abandoned~~) by a licensed well driller under a permit issued by the Director in accordance with these Rules. (3-18-22)()

037. -- 039. (RESERVED)

040. AREAS OF DRILLING CONCERN (RULE 40).

01. General. (3-18-22)

a. The Director may designate an “area of drilling concern” to protect public health, or to prevent waste and contamination of ground or surface water, or both, because of factors such as aquifer pressure, vertical depth to the aquifer, warm or hot ground water, or contaminated ground or surface waters. (3-18-22)

b. The designation of an area of drilling concern does not supersede or preclude designation of part or all of an area as a Critical Ground Water Area (Section 42-233a, Idaho Code), Ground Water Management Area (Section 42-233b, Idaho Code), or Geothermal Resource Area (Sections 42-4002 and 42-4003, Idaho Code). (3-18-22)

c. The designation of an area of drilling concern can include certain aquifers or portions thereof while excluding others. The area of drilling concern may include low temperature geothermal resources while not including the shallower cold ground water systems. (3-18-22)

02. Bond Requirement. (3-18-22)

a. The minimum bond to be filed by the well driller with the Director for the construction or

modification of any well in an area of drilling concern is ten thousand dollars (\$10,000) unless it can be shown to the satisfaction of the Director that a smaller bond is sufficient. (3-18-22)

b. The Director may determine on a case-by-case basis if a larger bond is required based on the estimated cost to repair, complete or properly decommission ~~(abandon)~~ a well. (3-18-22)()

03. Additional Requirements. (3-18-22)

a. A driller must demonstrate to the satisfaction of the Director that he has the experience and knowledge to adequately construct or decommission ~~(abandon)~~ a well which encounters warm water or pressurized aquifers. (3-18-22)()

b. A driller must demonstrate to the satisfaction of the Director that he has, or has immediate access to, specialized equipment or resources needed to adequately construct or decommission ~~(abandon)~~ a well. (3-18-22)()

041. -- 044. (RESERVED)

045. DRILLING PERMIT REQUIREMENTS (RULE 45).

01. General Provisions. (3-18-22)

a. Drilling permits are required pursuant to Section 42-235, Idaho Code, prior to construction or modification of any well. (3-18-22)

b. Drilling permits will not be issued for construction of a well which requires another separate approval from the department, such as a water right permit, transfer, amendment or injection well permit, until the other separate permitting requirements have been satisfied. (3-18-22)

c. The Director may allow the use of a start card permit or give verbal approval to a well driller for the construction of cold water single family domestic wells. Start cards must be received by the Department at least two office hours prior to commencing construction of the well. (3-18-22)

d. The Director may give verbal approval to a well driller for the construction of a well for which other permitting requirements have been met, provided that the driller or owner has filed the drilling permit application and appropriate fee. (3-18-22)

e. ~~The Director will not give a v~~Verbal approval ~~or allow~~ and the use of a start card permits for wells constructed in a designated Area of Drilling Concern, Critical Ground Water Area, ~~or~~ Ground Water Management Area and Areas of Contamination are not allowed unless otherwise authorized by the Director. (3-18-22)()

f. A well driller will not construct, drill or modify any well until a drilling permit has been issued, or verbal approval granted. (3-18-22)

02. Effect of a Permit. (3-18-22)

a. A drilling permit authorizes the construction or modification of a well in compliance with these rules and the conditions of approval on the permit. (3-18-22)

b. A drilling permit does not constitute a water right, injection well permit or other authorization which may be required, authorizing use of water from a well or discharge of fluids into a well. (3-18-22)

c. A drilling permit may not be assigned from one owner to another or from one driller to another. (3-18-22)

d. A drilling permit authorizes the construction of one (1) well, except for blanket monitoring well and blanket remediation well drilling permits. (3-18-22)

03. Exclusions. For the purposes of these Rules, artificial openings and excavations that do not constitute a well and are not subject to the drilling permit requirements must be modified, constructed, or decommissioned ~~(abandoned)~~ in accordance with minimum well construction standards. The Director may require decommissioning ~~(abandonment)~~ of artificial openings and excavations constructed pursuant to Rule 45, Subsection 045.03 of these rules, when the use ceases or if the holes may contribute to waste or contamination of the ground water. The following types of artificial openings and excavations are not considered wells: (3-18-22)()

- a. Artificial openings and excavations with total depth less than eighteen (18) feet. (3-18-22)
- b. Artificial openings and excavations for ~~collecting soil or rock samples, determining geologic properties, or~~ mineral exploration or extraction, including gravel pits. (3-18-22)()
- c. Artificial openings and excavations for oil and gas exploration for which a permit has been issued pursuant to Section 47-320, Idaho Code. (3-18-22)
- d. Artificial openings and excavations constructed for de-watering building or dam foundation excavations. (3-18-22)
- e. Artificial openings and excavations for collecting soil and rock samples and determining geologic properties above and below the water table. Drill rig(s) and support equipment are to remain onsite until the geotechnical boring(s) are decommissioned in accordance with these rules. ()
- f. Horizontal borings for utility installations. ()

~~**04. Converting an Artificial Openings or Excavations Not Constructed as a Well for Use as a Well.** Artificial openings and excavations that were not constructed as a well pursuant to a drilling permit, if subsequently converted to obtain water, monitor water quantity or quality, or to dispose of water or other fluids, must be reconstructed by a licensed driller in compliance with well construction standards and drilling permit requirements. (3-18-22)~~

~~**054. Fees.** (3-18-22)~~

~~a. Drilling permit fees are as prescribed by Section 42-235, Idaho Code. (3-18-22)~~

~~b. The difference between the drilling permit fee required by Section 42-235 Idaho Code as applicable, must be paid when an existing well constructed on or after July 1, 1987, for which the lower drilling permit fee was paid, is authorized by the Director for a use which would require the larger drilling permit fee. (3-18-22)~~

046. -- 049. (RESERVED)

050. PENALTIES (RULE 50).

A person owning or controlling a well that allows waste or contamination of the state's ground water resources or causes a well not to meet the construction standards provided in these Rules is subject to the civil penalties as provided by statute. A driller who violates the foregoing provisions of these well construction standards Rules is subject to enforcement action and the penalties as provided by Statute. (3-18-22)

051. -- 999. (RESERVED)

APPENDIX A
Figure 01. Concrete Slabs and Finished Grade

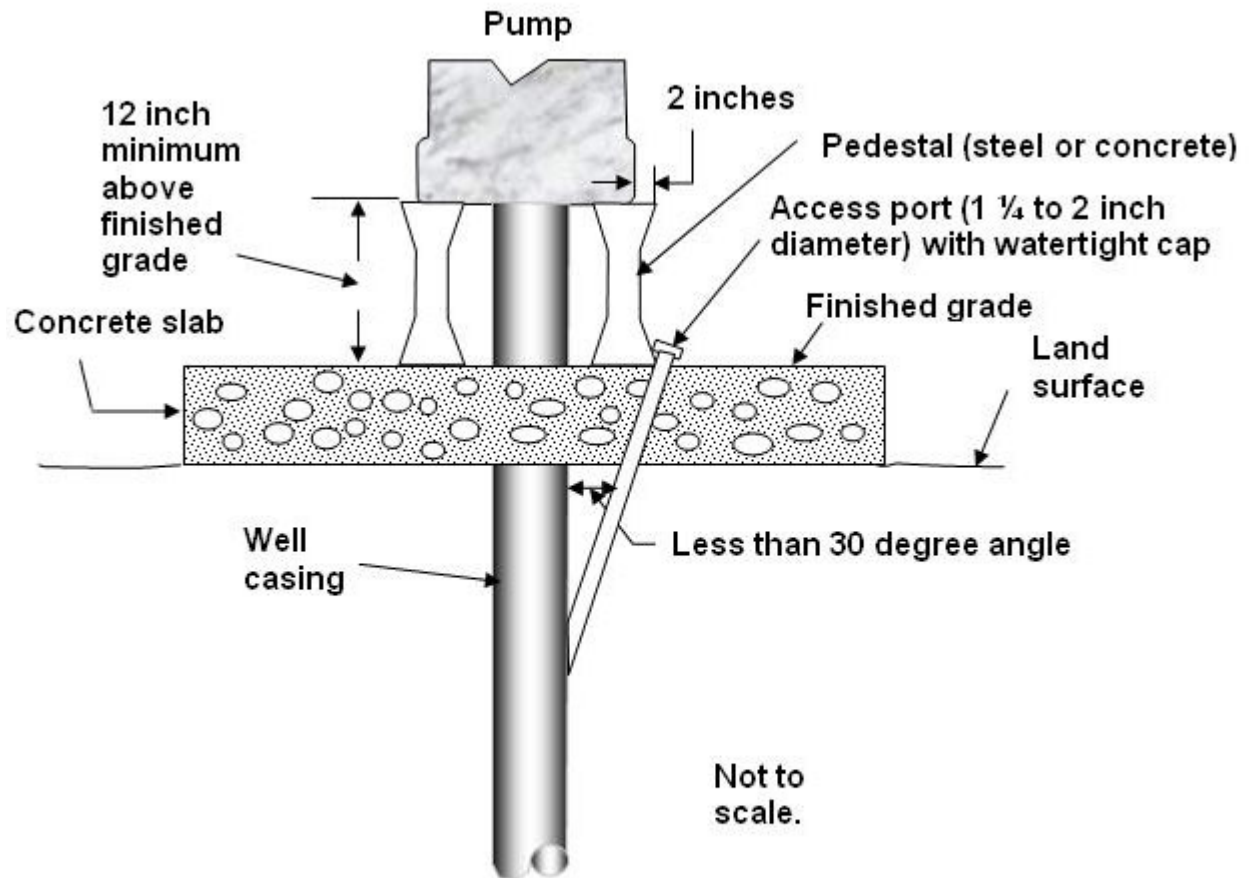

Note. Pedestal shall not extend more than two (2) inches past pump base in horizontal direction.

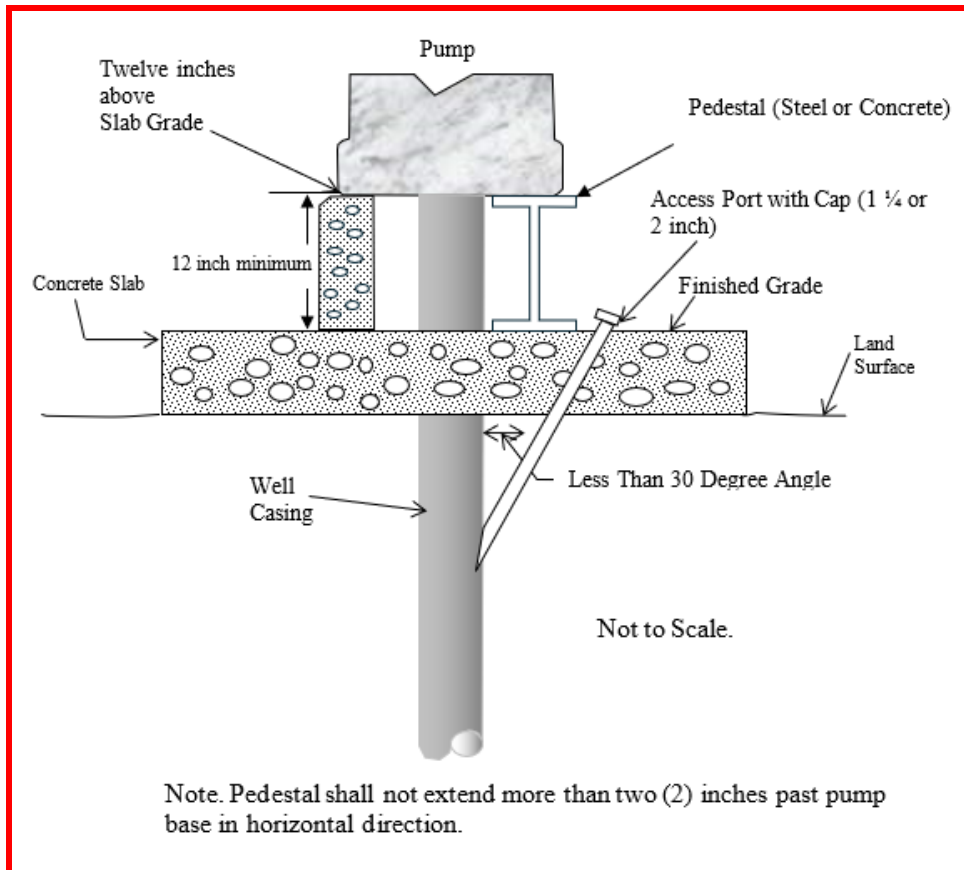

Figure 02. Annular Space and Overbore

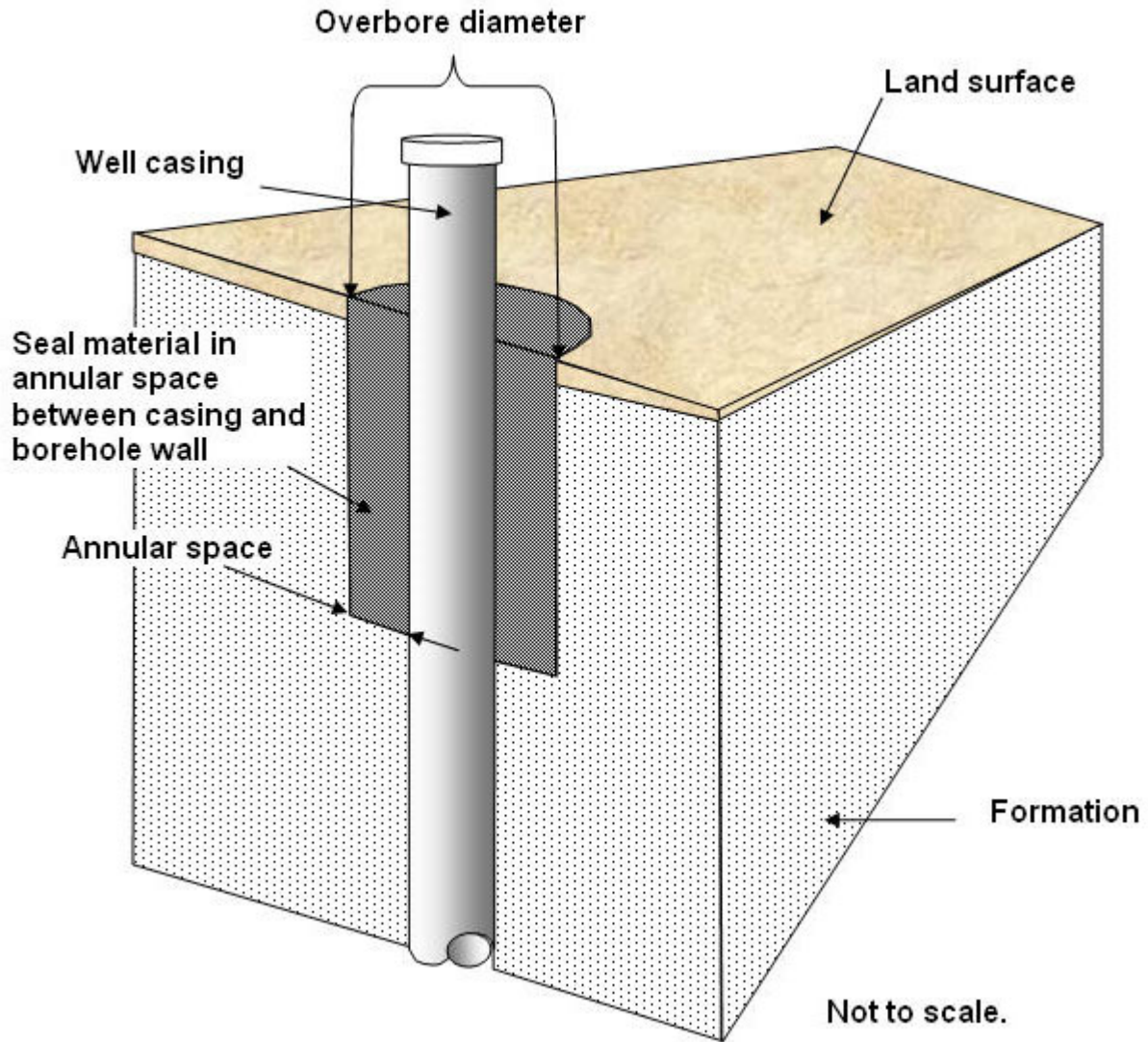

Figure 03. Overbore Requirements When a Tremie Pipe is Left in Place and A Grout Seal Installed

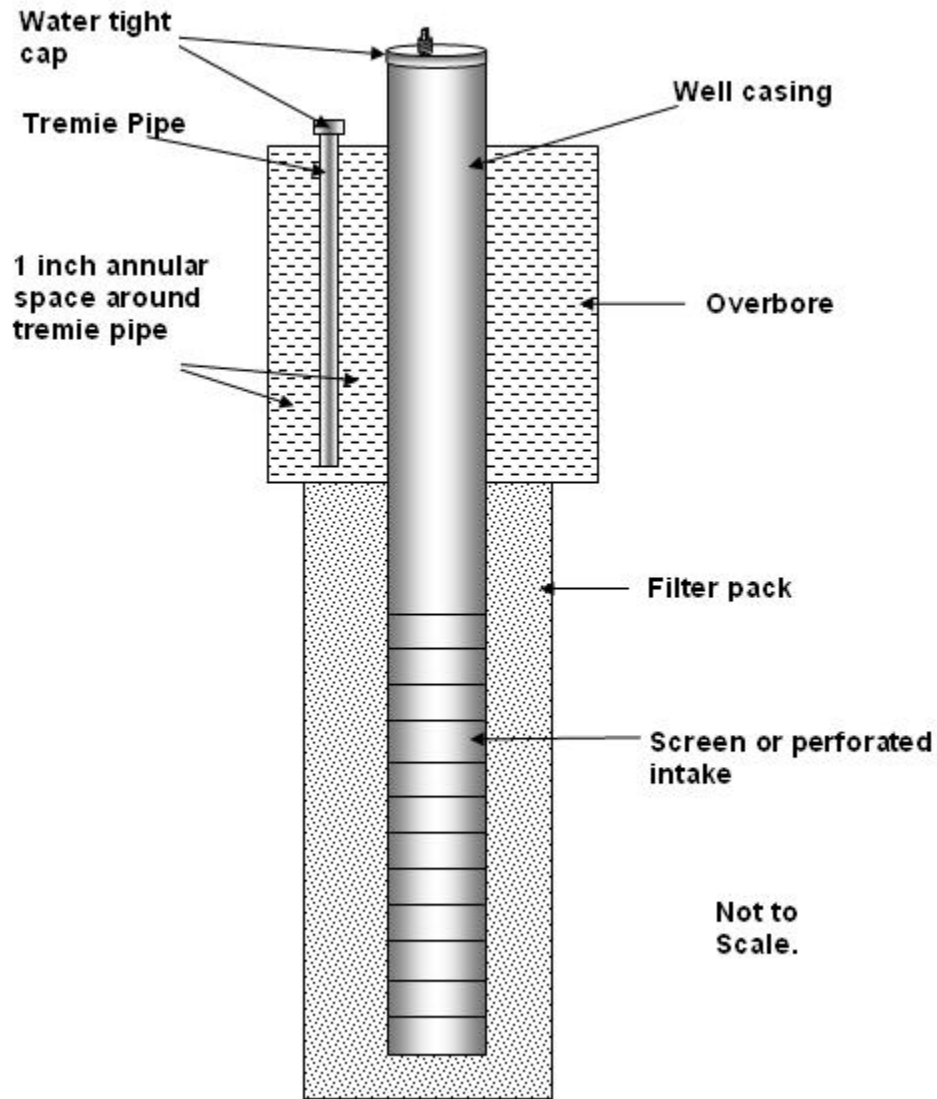

Figure 04. Sealing Requirements in Consolidated Formations

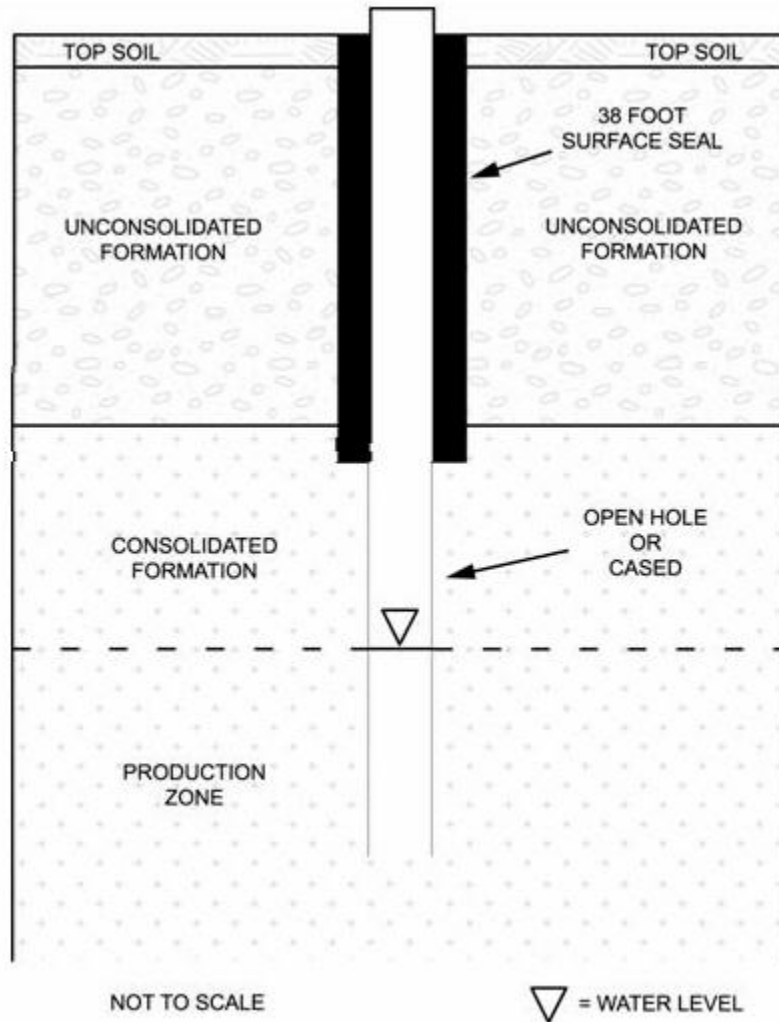

Figure 05. Sealing Requirements in Unconsolidated Formation without Confining Layers

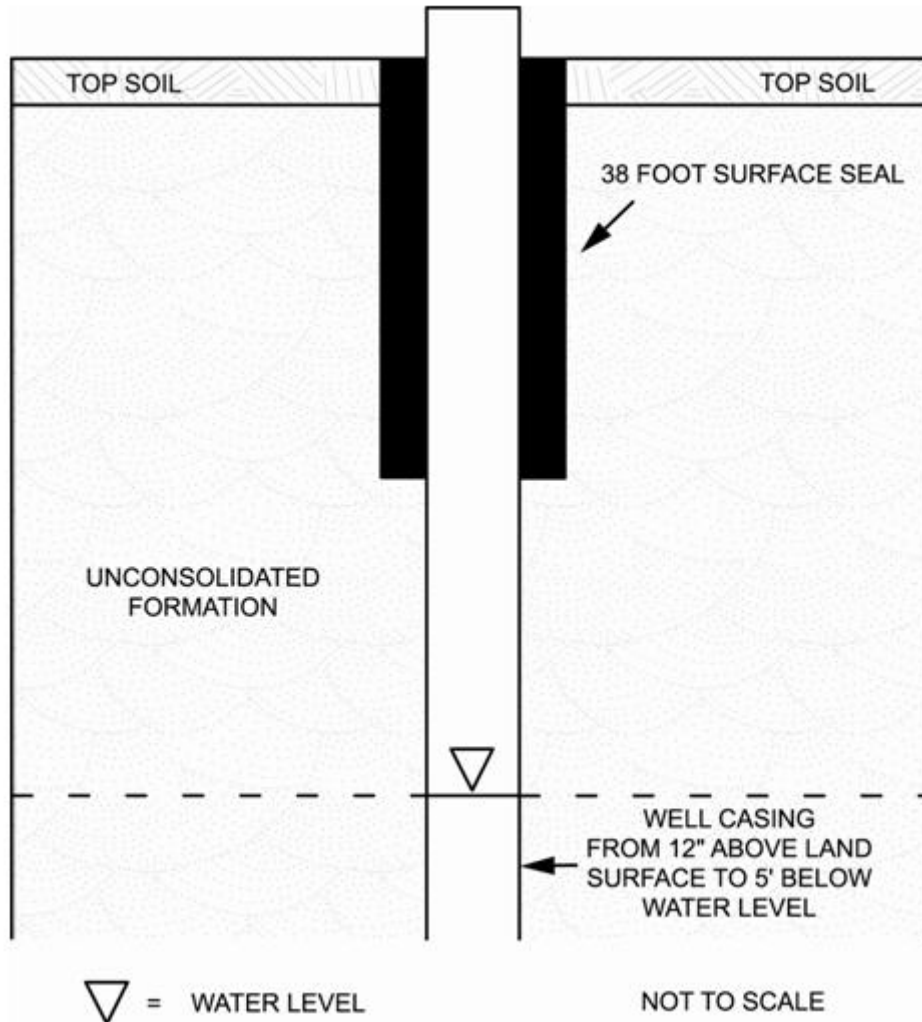

Figure 06. Rathdrum Prairie Boundary

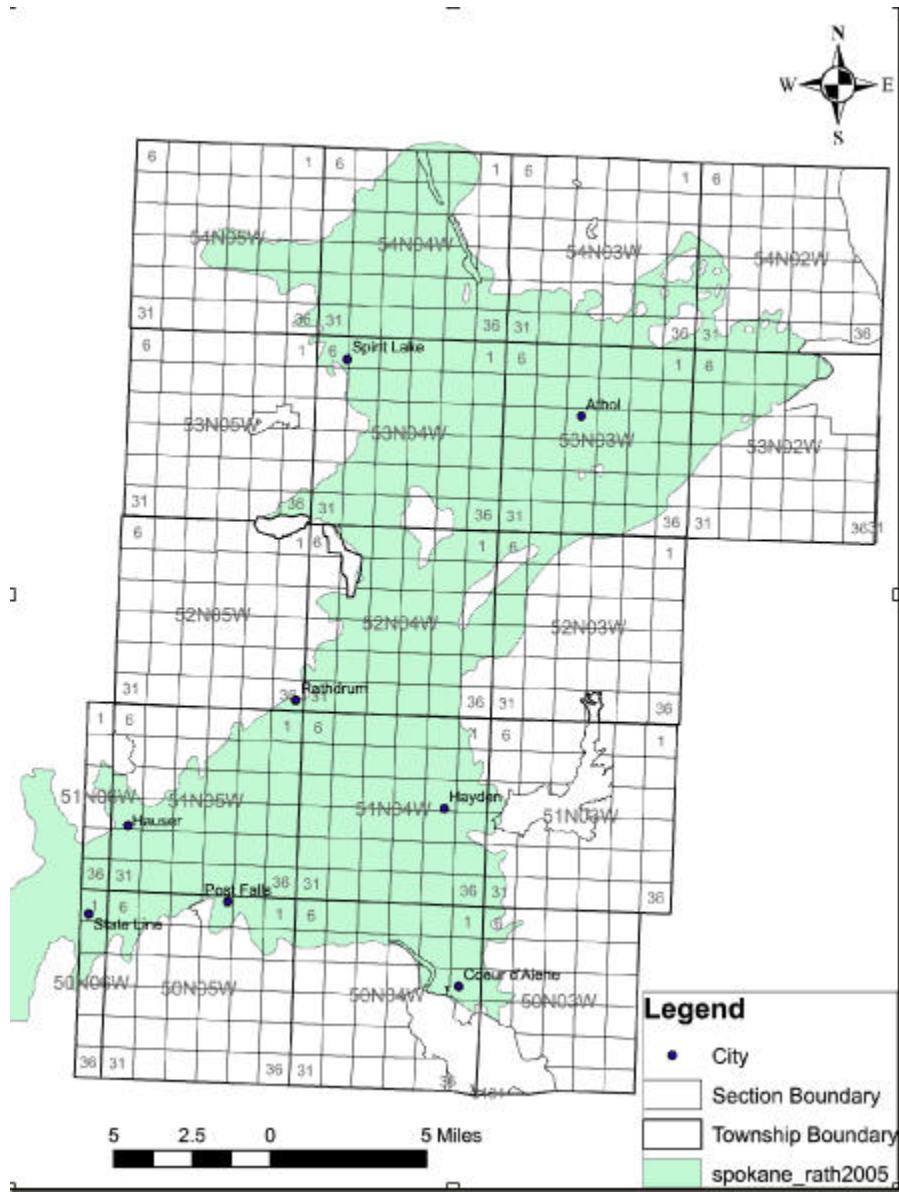

Figure 07. Sealing Requirements in the Rathdrum Prairie

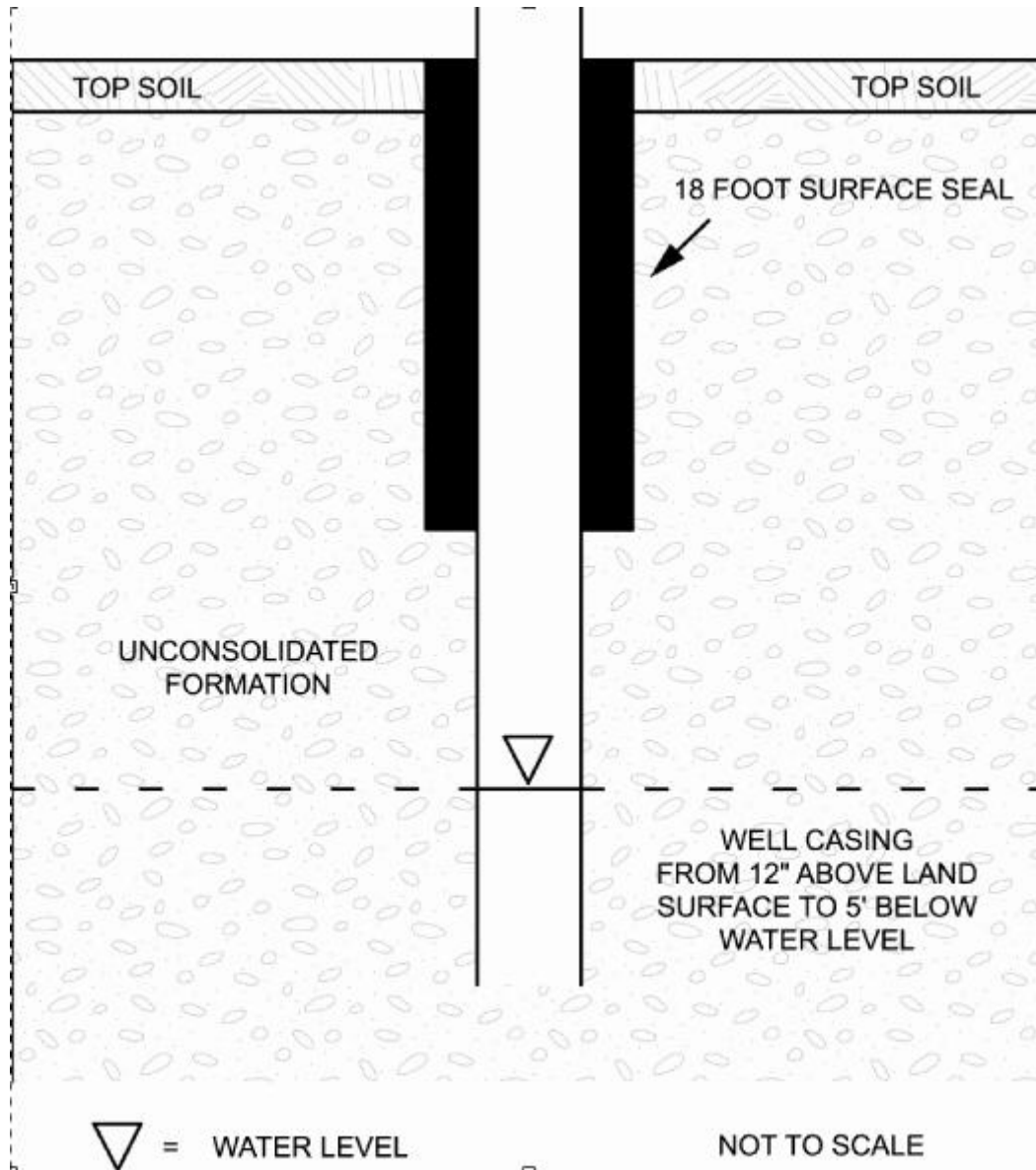

Figure 08. Sealing Requirements in Unconsolidated Formations with Confining Layers

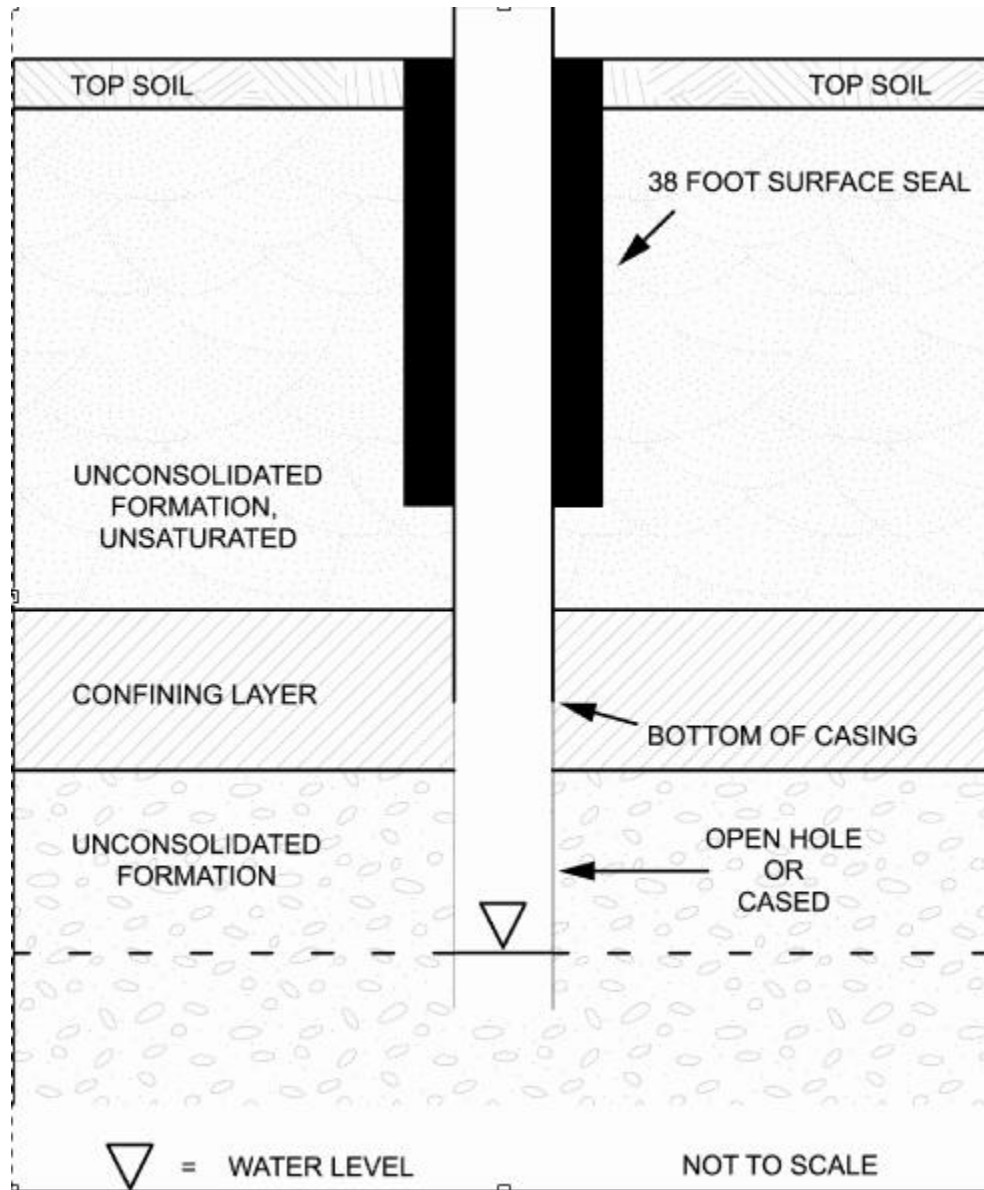

Figure 09. Sealing Requirements for Artesian Wells in Unconsolidated Formations

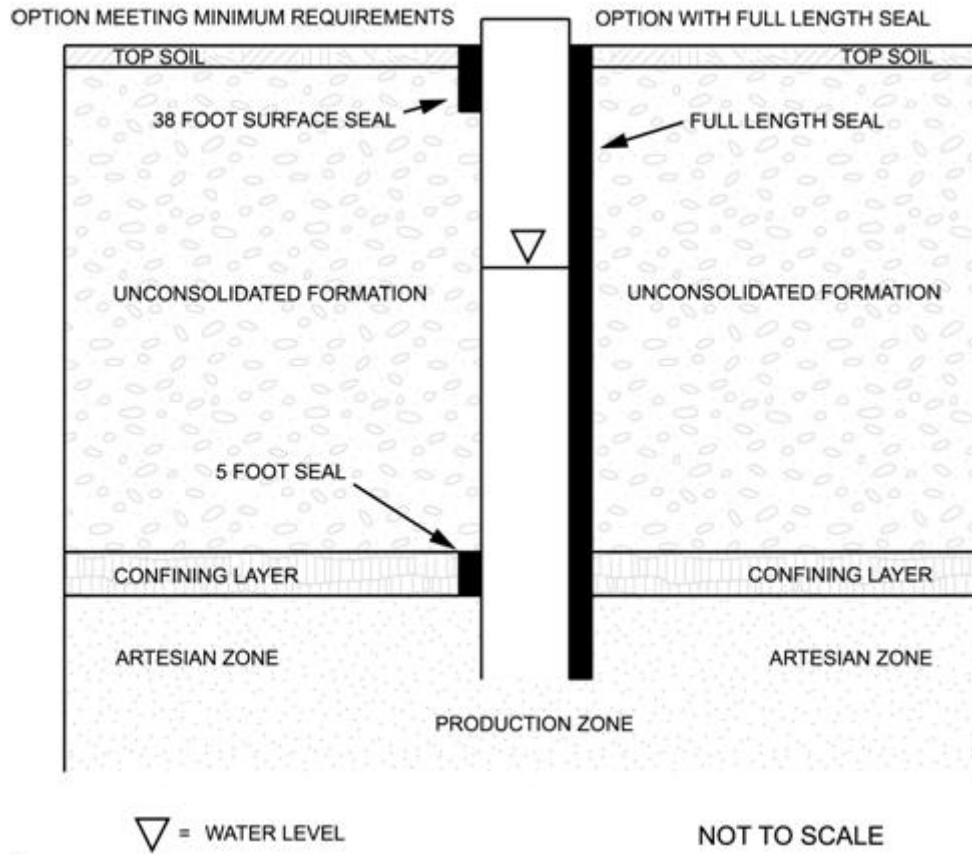

Figure 10. Sealing Requirements for Artesian Wells in Consolidated Formations

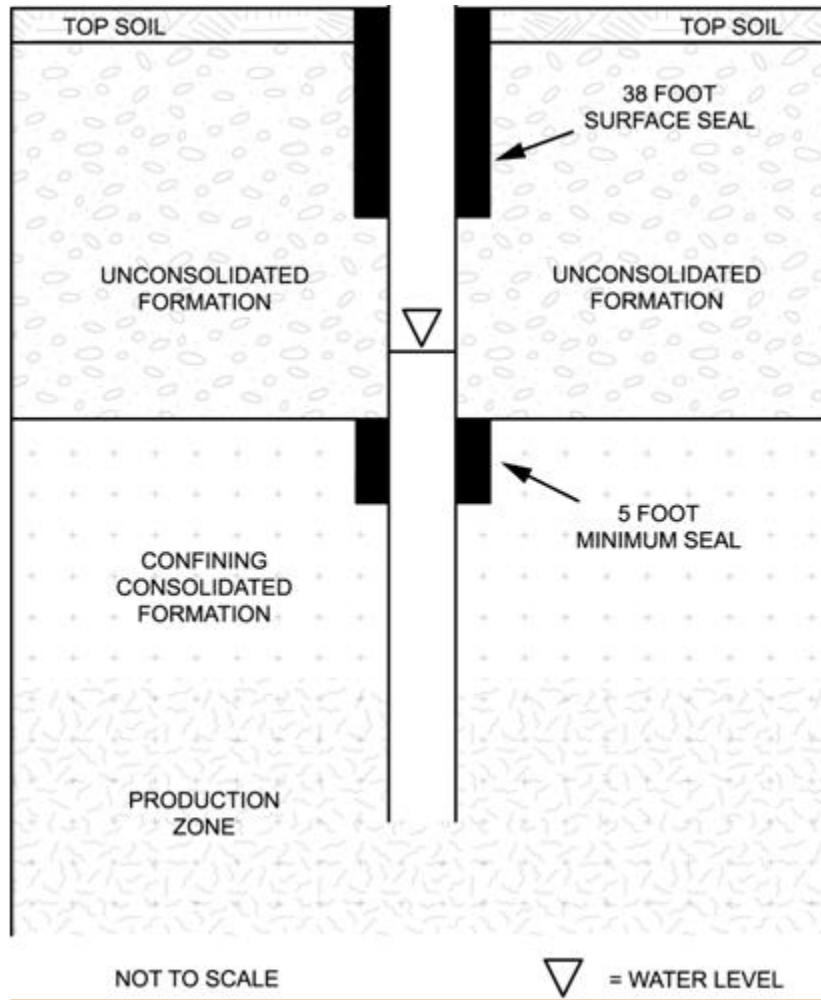
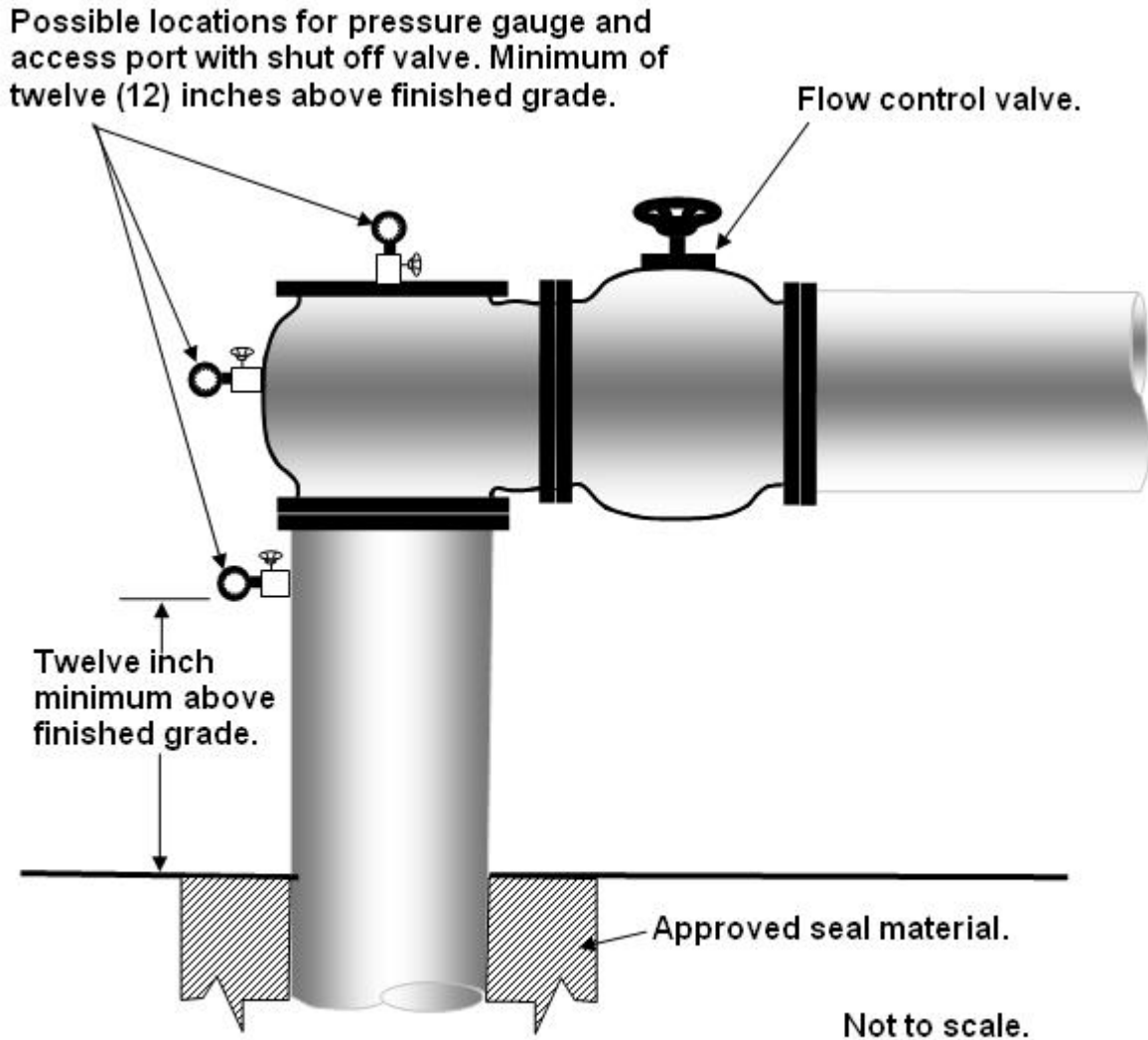

Figure 11. Access Ports, Pressure Gauges, and Control Valves



Note. Application and approval of control device is required on any flowing artesian well per Section 42-1603, Idaho Code.

Figure 12. Well Cap and Access Port

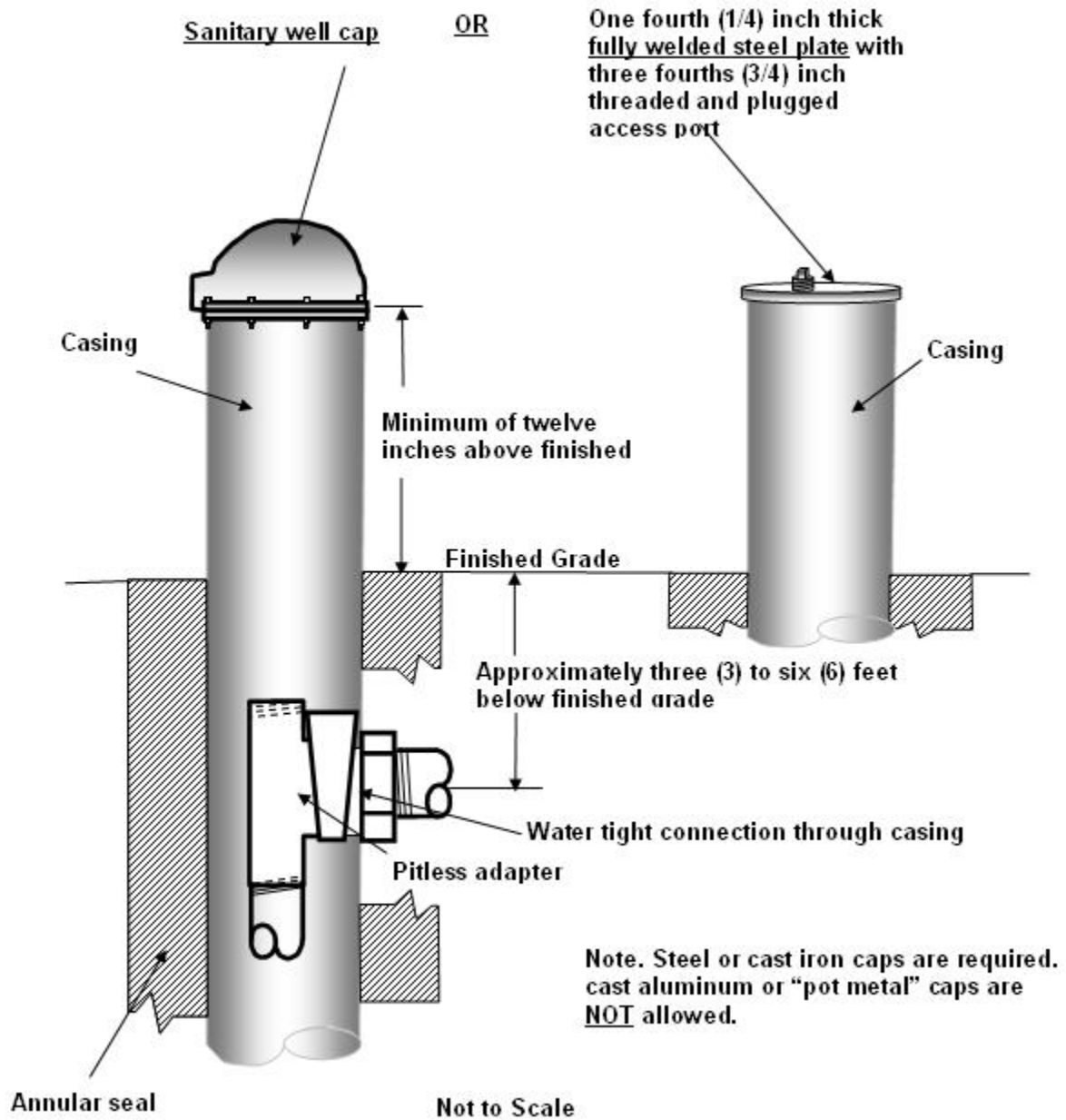
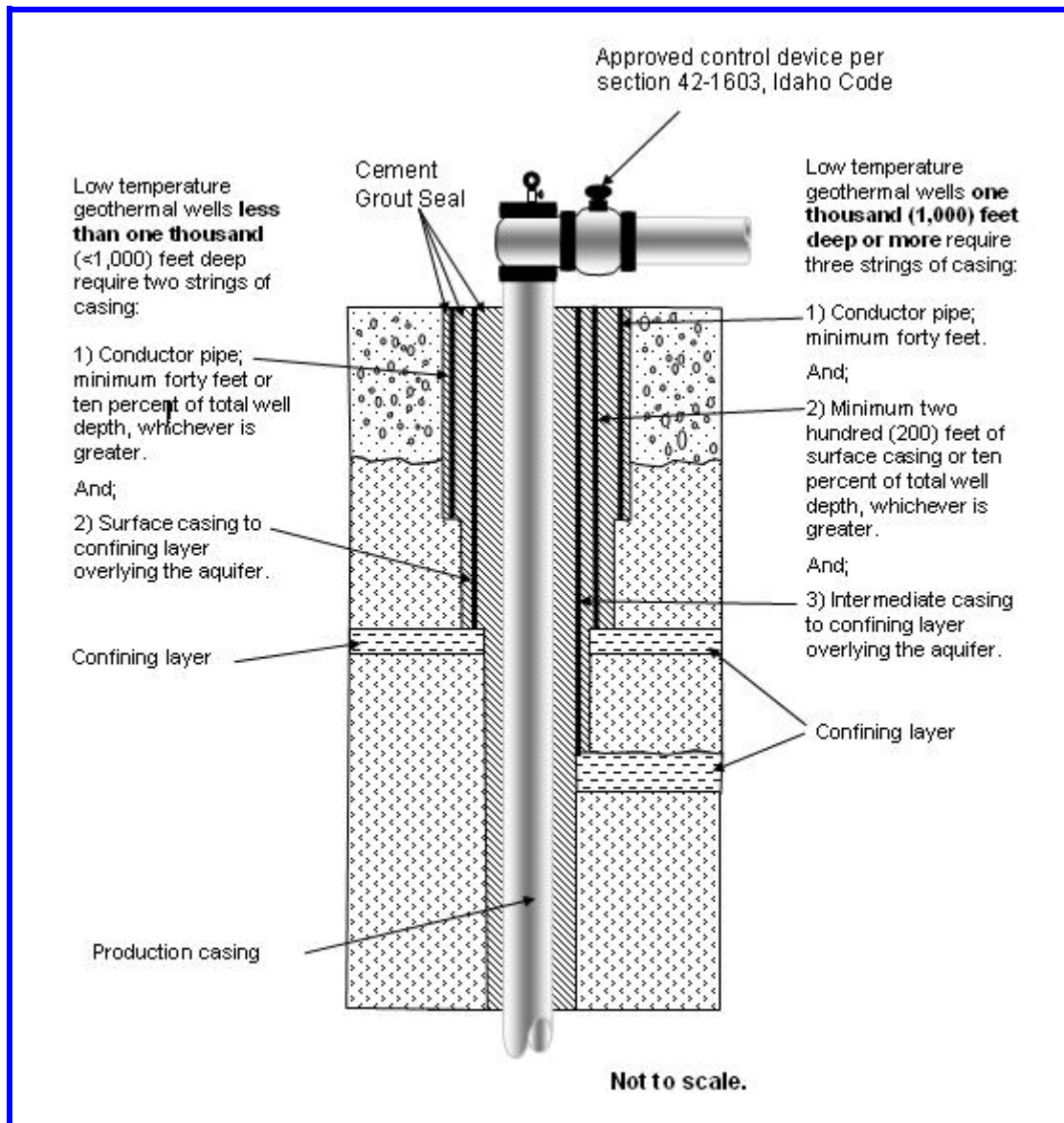
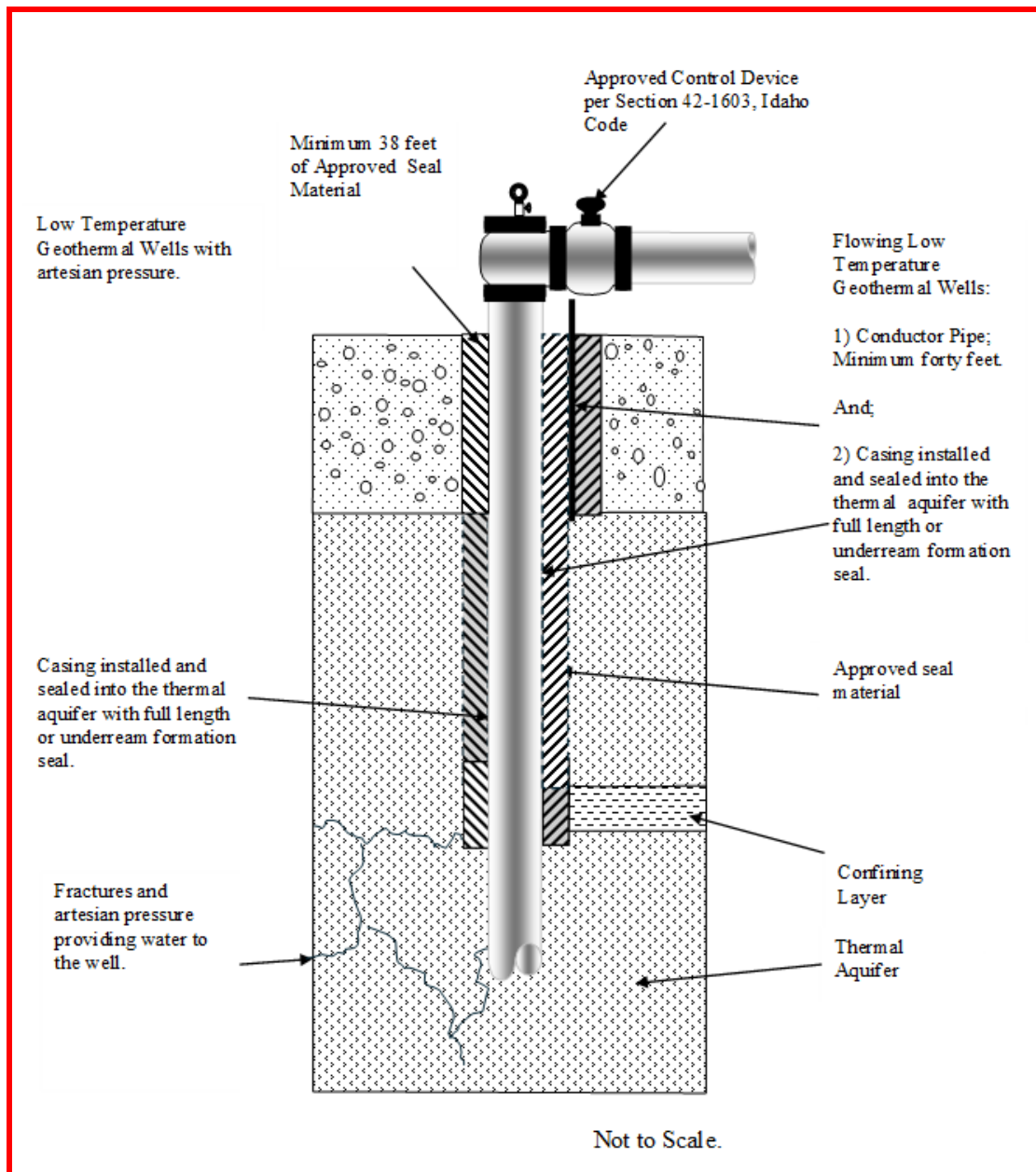

Figure 13. Casing Requirements for Low Temperature Geothermal Wells





IDAPA 37 – IDAHO DEPARTMENT OF WATER RESOURCES

37.03.11 – RULES FOR CONJUNCTIVE MANAGEMENT OF SURFACE AND GROUND WATER RESOURCES

DOCKET NO. 37-0311-2401

NOTICE OF RULEMAKING – PROPOSED RULE

AUTHORITY: In compliance with Section 67-5221(1), Idaho Code, notice is hereby given that this agency has initiated proposed rulemaking procedures. The action is authorized pursuant to Section 42-1805(8), Idaho Code.

PUBLIC HEARING SCHEDULE: Public hearing(s) concerning this rulemaking will be scheduled if requested in writing by twenty-five (25) persons, a political subdivision, or an agency, not later than October 16, 2024.

The hearing site(s) will be accessible to persons with disabilities. Requests for accommodation must be made not later than five (5) days prior to the hearing, to the agency address below.

DESCRIPTIVE SUMMARY: The following is a nontechnical explanation of the substance and purpose of the proposed rulemaking:

The Idaho Department of Water Resources (IDWR) initiated this rulemaking to align IDAPA 37.03.11.050 (Rule 50) with Section 42-233c, Idaho Code. Section 42-233c, Idaho Code, effective on and after July 1, 2024, clarifies the area having a common ground water supply for the Eastern Snake Plain Aquifer (ESPA). This targeted change will ensure continuity between statute and rule.

With this Notice, IDWR proposes an amendment of Rules for Conjunctive Management of Surface and Ground Water Resources.

The proposed rule text may be viewed at: <https://idwr.idaho.gov/legal-actions/rules/idwr-rulemaking-2024-2025/conjunctive-management-rules/>. On the same website, IDWR also published rulemaking support documents, which includes Senate Bill 1341 at: <https://legislature.idaho.gov/sessioninfo/2024/legislation/S1341/>, and Section 42-233c, Idaho Code, at: <https://legislature.idaho.gov/statutesrules/idstat/Title42/T42CH2/SECT42-233c/>.

After consideration of public comments received in response to this Proposed Rule, IDWR will present the final rule text during the 2025 Legislative Session.

FEE SUMMARY: The following is a specific description of the fee or charge imposed or increased: N/A.

FISCAL IMPACT: The following is a specific description, if applicable, of any negative fiscal impact on the state General Fund greater than ten thousand dollars (\$10,000) during the fiscal year resulting from this rulemaking: NA.

NEGOTIATED RULEMAKING: Pursuant to Section 67-5220, Idaho Code, negotiated rulemaking was not conducted because the amendment to Rule 50 is necessary to align the rule with the provisions of Section 42-233c, Idaho Code, that came into effect on July 1, 2024. This amendment ensures consistency and continuity between the statute and the rule.

INCORPORATION BY REFERENCE: Pursuant to Section 67-5229(2)(a), Idaho Code, the following is a brief synopsis of why the materials cited are being incorporated by reference into this rule: NA.

ASSISTANCE ON TECHNICAL QUESTIONS, SUBMISSION OF WRITTEN COMMENTS: For assistance on technical questions concerning the proposed rule, contact Erik Boe at Erik.Boe@idwr.idaho.gov, (208) 287-4800.

Anyone may submit written comments regarding this proposed rulemaking by mail to the address below or by email to rulesinfo@idwr.idaho.gov. All written comments must be directed to the undersigned and must be delivered on or before October 23, 2024.

DATED this 11th day of September, 2024.

Erik Boe, Water Compliance Bureau Chief, Rules Regulation Officer
Idaho Department of Water Resources
322 E. Front Street
PO Box 83720 Boise, ID 83720-0098
Phone: (208) 287-4800

THE FOLLOWING IS THE PROPOSED TEXT OF DOCKET NO. 37-0311-2401
(Only Those Sections With Amendments Are Shown.)

37.03.11 – RULES FOR CONJUNCTIVE MANAGEMENT OF SURFACE
AND GROUND WATER RESOURCES

050. AREAS DETERMINED TO HAVE A COMMON GROUND WATER SUPPLY (RULE 50).

01. Eastern Snake Plain Aquifer. The area of coverage of this rule is the aquifer underlying the Eastern Snake River Plain as ~~the aquifer is defined in the report, Hydrology and Digital Simulation of the Regional Aquifer System, Eastern Snake River Plain, Idaho, USGS Professional Paper 1408-F, 1992 excluding areas south of the Snake River and west of the line separating Sections 34 and 35, Township 10 South, Range 20 East, Boise Meridian defined in Section 42-233c, Idaho Code.~~ (3-31-22)()

~~**a.** The Eastern Snake Plain Aquifer supplies water to and receives water from the Snake River. (3-31-22)~~

~~**b.** The Eastern Snake Plain Aquifer is found to be an area having a common ground water supply. (3-31-22)~~

~~**e.** The reasonably anticipated average rate of future natural recharge of the Eastern Snake Plain Aquifer will be estimated in any order issued pursuant to Rule 30. (3-31-22)~~

~~**d.** The Eastern Snake Plain Aquifer area of common ground water supply will be created as a new water district or incorporated into an existing or expanded water district as provided in Section 42-604, Idaho Code, when the rights to the diversion and use of water from the aquifer have been adjudicated, or will be designated a ground water management area. (3-31-22)~~

IDAPA 38 – DEPARTMENT OF ADMINISTRATION

38.05.01 – RULES OF THE DIVISION OF PURCHASING

DOCKET NO. 38-0501-2401

NOTICE OF INTENT TO PROMULGATE RULES – NEGOTIATED RULEMAKING

AUTHORITY: In compliance with Section 67-5221(1), Idaho Code, notice is hereby given that this agency has initiated proposed rulemaking procedures. The action is authorized pursuant to Sections 67-9204, 67-9205, 67-9206, 67-9215, 67-9219, 67-9226, Idaho Code.

MEETING SCHEDULE: Negotiated meetings have been scheduled and all scheduled meetings shall be posted and made accessible on the following agency website address: Welcome to Department of Administration (adm.idaho.gov).

GENERAL PUBLIC MEETING

Tuesday, October 8, 2024

1:00 P.M. (Mountain Time)

In Person:

**Joe R. Williams Building
First Floor, West Conference Room
700 W. State Street
Boise, Idaho 83702**

Join by Phone:

+1 (208) 985-2810

When prompted, please enter code 139696836

The hearing site(s) will be accessible to persons with disabilities. Requests for accommodation must be made not later than five (5) days prior to the hearing, to the agency address below.

METHOD OF PARTICIPATION: Persons wishing to participate in the negotiated rulemaking must do any of the following:

- Attend the negotiated rulemaking meeting(s), in person or through teleconference, and participate in the negotiation process;
- Submit written comments to the address below.

Upon conclusion of the negotiated rulemaking, any unresolved issues, all key issues considered, and conclusion reached during the negotiated rulemaking will be addressed in a written summary. The summary will be made available to interested persons who contact the agency or, if the agency chooses, the summary may be posted on the agency website.

DESCRIPTIVE SUMMARY: The following is a nontechnical explanation of the substance and purpose of the proposed rulemaking:

This rulemaking removes, as agreed to with the legislature, all references and processes related to the invitation to negotiate. The Department is, pursuant to the Governor’s zero-based regulation initiative, also utilizing this rulemaking to perform another comprehensive review of the purchasing rules to make several updates to the rule chapter, simplify and streamline the rules, and ensure alignment between the rule chapter and the governing statutes.

ASSISTANCE ON TECHNICAL QUESTIONS, SUBMISSION OF WRITTEN COMMENTS: For assistance on technical questions concerning the proposed rule, contact Kim Rau, (208) 332-1824.

Anyone may submit written comments regarding this proposed rulemaking. All written comments must be directed to the undersigned and must be delivered on or before October 16, 2024.

DATED this 2nd day of October, 2024.

Steve Bailey, Director
Department of Administration
650 W. State Street
Room 100
Boise, Idaho 83720
steven.bailey@adm.idaho.gov
(208) 332-1824

IDAPA 39 – IDAHO TRANSPORTATION DEPARTMENT

39.02.03 – RULES GOVERNING VEHICLE DEALER’S PRINCIPAL PLACE OF BUSINESS AND CLAIMS TO THE IDAHO CONSUMER ASSET RECOVERY FUND

DOCKET NO. 39-0203-2401 (ZBR CHAPTER REWRITE)

NOTICE OF RULEMAKING – PROPOSED RULE

AUTHORITY: In compliance with Section 67-5221(1), Idaho Code, notice is hereby given that this agency has initiated proposed rulemaking procedures. The action is authorized pursuant to Sections 49-201(1) and 49-1608F(9), Idaho Code.

PUBLIC HEARING SCHEDULE: Public hearing(s) concerning this rulemaking will be scheduled if requested in writing by twenty-five (25) persons, a political subdivision, or an agency, not later than October 16, 2024.

The hearing site(s) will be accessible to persons with disabilities. Requests for accommodation must be made not later than five (5) days prior to the hearing, to the agency address below.

DESCRIPTIVE SUMMARY: The following is a nontechnical explanation of the substance and purpose of the proposed rulemaking:

This rule clarifies terms used in the statutory definition of “principal place of business” and provides for definitions and processes for payment of claims from the Idaho Consumer Asset Recovery Fund. This rule was reviewed in accordance with the agency’s Zero-Based Regulation review schedule. The proposed edits clarify several provisions and are non-substantive in nature.

FEE SUMMARY: The following is a specific description of the fee or charge imposed or increased: N/A.

FISCAL IMPACT: The following is a specific description, if applicable, of any negative fiscal impact on the state General Fund greater than ten thousand dollars (\$10,000) during the fiscal year resulting from this rulemaking: N/A.

NEGOTIATED RULEMAKING: Pursuant to Section 67-5220(1), Idaho Code, negotiated rulemaking was conducted. The Notice of Intent to Promulgate Rules - Negotiated Rulemaking was published in the May 1, 2024, Idaho Administrative Bulletin, [Vol. 24-5, pages 236-237](#).

INCORPORATION BY REFERENCE: Pursuant to Section 67-5229(2)(a), Idaho Code, the following is a brief synopsis of why the materials cited are being incorporated by reference into this rule: N/A.

ASSISTANCE ON TECHNICAL QUESTIONS, SUBMISSION OF WRITTEN COMMENTS: For assistance on technical questions concerning the proposed rule, contact Brendan Floyd at 208-334-8474.

Anyone may submit written comments regarding this proposed rulemaking. All written comments must be directed to the undersigned and must be delivered on or before October 23, 2024.

DATED this 30th day of August, 2024.

Brendan Floyd
Policy Specialist
Idaho Transportation Department
11331 W. Chinden Blvd.
Boise, ID 83714
208-334-8474
Brendan.floyd@itd.idaho.gov

THE FOLLOWING IS THE PROPOSED TEXT OF DOCKET NO. 39-0203-2401
(ZBR Chapter Rewrite)

39.02.03 – RULES GOVERNING VEHICLE DEALER'S PRINCIPAL PLACE OF BUSINESS
AND CLAIMS TO THE IDAHO CONSUMER ASSET RECOVERY FUND

000. LEGAL AUTHORITY.

This rule is adopted under the authority of Sections 49-201(1), and 49-1608F(9) Idaho Code ~~and the Vehicle Dealer Act, Chapter 16, Title 49, Idaho Code.~~ (3-31-22)()

001. ~~TITLE AND SCOPE~~ PURPOSE.

01. ~~Title.~~ Title. This rule will be titled IDAPA 39.02.03, "Rules Governing Vehicle Dealer's Principal Place of Business and Claims to the Idaho Consumer Asset Recovery Fund." (3-31-22)

02. ~~Scope.~~ Scope. This rule clarifies terms used in the definition of "principal place of business" and ~~provisions regarding these terms and~~ prescribes procedures for the payment of claims from the Idaho Consumer Asset Recovery Fund. (3-31-22)()

002. -- 009. (RESERVED)

010. DEFINITIONS.

01. Vehicle Dealer File System. Books, records and files, necessary to conduct the business of a vehicle dealership. ~~In accordance with the Vehicle Dealer Act, r~~ Records ~~shall~~ will be securely kept by the dealership in such order that they can be readily inspected by a Department Investigator. Such records and files may be kept electronically, as long as such records can be verified by the dealership as true and correct copies of the original records. Physical records or files retained by the dealership may be stored at an off-site location. The dealership ~~must~~ will notify the department 30 days in advance of the address of the off-site location prior to moving such records. Records or files stored off-site ~~must~~ will be made available to the department within 3 business days upon request. The files and records ~~shall~~ will contain but are not limited to: (3-31-22)()

- a. Physical or electronic sales invoices for current and two (2) preceding years; (3-31-22)
- b. Physical or electronic copies of purchase orders for vehicles purchased for current and two (2) preceding years; (3-31-22)
- c. Physical or electronic copies of title application forms accessible in numerical order; (3-31-22)
- d. Written or electronic records of vehicles bearing new or used dealers' number plates and their use by a manufacturer, vehicle dealer, or full-time licensed salespersons searchable by date, time or plate number; (3-31-22)
- e. Written or electronic records for loaner plates searchable by date, time or plate number; (3-31-22)
- f. Copies or electronic records of Wholesale Dealer Forms records showing, all transactions, as applicable searchable by date or name of consignee; (3-31-22)
- g. Physical or electronic odometer disclosure records for non-exempt vehicles; and (3-31-22)
- h. Physical or electronic records of consignment agreements, as specified in Section 49-1636, Idaho Code. (3-31-22)

i. All electronic records ~~must~~ will be created in a secure manner to prevent such records from being altered. Electronic copies of records ~~must~~ will be legible, complete, and an accurate reproduction of the original business record. (3-31-22)()

j. All electronic copies of records ~~shall~~ will be supplemented with a back-up copy of the electronic records, ~~either retained on-site or an off-site location, which permits the business record to be retrieved within three (3) business days.~~ (3-31-22)()

k. Any device, server, network device, or any internal or external storage medium which stores the electronic records ~~must~~ will have security access controls and physical security measures to protect the records from unauthorized access, viewing, or alteration. (3-31-22)()

l. Any dealer storing electronic or physical records that contain personal information ~~shall~~ will ensure that disposal of any records be completed in a secure manner, by shredding, erasing, or otherwise modifying the personal information to make it unreadable or undecipherable through any means. (3-31-22)()

02. Vehicle Dealer Sign Requirements. An exterior sign permanently affixed to the land or building, with clearly visible letters, visible to major avenue of traffic meeting local building or zoning codes with the trade name of the dealership clearly visible ~~is required from fifty (50) feet.~~ Wholesale dealer signs may be painted on the window of the office next to the entrance door of sufficient size to be easily read by prospective customers. A suggested retail sign size is twenty-four (24) square feet, with a minimum of four (4) inch letters. (3-31-22)()

03. Telephone. A ~~business~~ phone that has a publicly published business number ~~and listing in a local telephone directory~~ in the name of the dealership. Business phones ~~shall~~ will be answered during declared business hours, in the name of the licensed dealer. ~~The telephone may be answered in person, by an answering machine, or at a remote location in person.~~ (3-31-22)()

011. -- 099. (RESERVED)

100. GENERAL PROVISIONS.

01. Physical or Electronic Records System Inspection. A vehicle dealer ~~shall~~ will make available all books, records and files maintained at the dealership location for immediate inspection for cause or complaint, or ~~within three (3) business days if records are stored at an approved off-site location~~ for random compliance review by a peace officer or authorized agent of the Department. (3-31-22)()

02. Dealer Title Fee Disclosure. ~~A dealer may reflect the payment of a state required title fee as specified by Section 49-202(2)(b), Idaho Code, however:~~ (3-31-22)()

a. The fee ~~must~~ will be clearly identified as a "TITLE FEE"; (3-31-22)()

b. The fee ~~must~~ will be shown as the exact amount required by law; (3-31-22)()

c. Any documentation fees charged ~~must~~ will be clearly listed separately from other fees and identified to the customer as dealer document preparation fees that are subject to sales tax as part of the purchase price of the vehicle. (3-31-22)()

~~**03. Surety Bond.** A valid bond in the amount required by Section 49-1608D, Idaho Code, for three (3) years after initially licensed, unless otherwise provided by code;~~ (3-31-22)

043. Idaho Consumer Asset Recovery (ICAR) Fund. (3-31-22)

a. All licensed dealers will pay the annual fee as set by the Idaho Consumer Asset Recovery (ICAR) Board as required by Section 49-1608C, Idaho Code, unless otherwise provided by code. (3-31-22)

b. The ICAR fund fee will be set by the ICAR Board annually to be effective the following January 1.

Such fee ~~shall~~ will be posted on the Department web site and all applicable forms for dealer licensing. (3-31-22)

~~05. Liability Insurance. A valid liability insurance policy as required by Section 49-1608A, Idaho Code.~~ (3-31-22)

~~064. Declared Business Hours. All licensed dealers shall declare in writing to the Department the regular business hours that their dealerships are open and when they are available to be contacted by the Department or their customers. All wholesale dealers shall declare in writing to the department the regular hours that their dealerships are open and when they are available to be contacted by the department or their customers.~~ (3-31-22)()

~~075. Vehicle Dealer License Suspension. Any dealer not meeting the requirements of the Vehicle Dealer Act Title 49, Idaho Code shall will~~ be subject to suspension of an existing dealer license or refusal by the Department to issue a new dealer license. (3-31-22)()

- a. The Department's agent will give written notice of deficiencies to the dealer or applicant. (3-31-22)
- b. At its discretion the Department may give the licensed dealership a reasonable amount of time to comply. (3-31-22)
- c. Upon compliance, the license will be reinstated or issued. (3-31-22)

101. -- 199. (RESERVED)

200. IDAHO CONSUMER ASSET RECOVERY FUND CONTROL BOARD ADMINISTRATION.

01. Quorum. A majority of the members of the Idaho Consumer Asset Recovery Control (ICAR) Board established pursuant to Section 49-1608C, Idaho Code, constitutes a quorum. A quorum is required for voting on any ICAR claims. The ICAR Board chairman presides over ICAR Board meetings. The ICAR Board operates in compliance with Idaho open meeting laws. (3-31-22)

02. Voting. All members of the ICAR Board constituting the quorum are entitled to vote in consideration of any payment of a claim pursuant to Section 49-1608F, Idaho Code. (3-31-22)

03. Actual Loss or Damages. As provided for in Section 49-1608E, Idaho Code, "actual loss or damages", means: The total cost to the purchaser, as set forth in a final judgement, of the loss directly resulting in a violation, by a dealer, of the provisions of Title 48, Chapter ~~5~~ 6 or Title 49, Chapter 5 or Section 49-1418, Idaho Code; including such things as repairs, inspections and loss of resale value. The term includes the attorney fees and costs in bringing suit against the dealer, and includes pre-judgement, but not post-judgement interest. "Actual Loss or Damages" ~~shall will~~ not include such things as treble damages, expectation damages nor consequential damages resulting from dealer fraud. (3-31-22)()

04. Complete and Complaint Claims. All ICAR claims will be initiated by filing the complete claim with the Idaho Transportation Department DMV Administrator. When a proper ICAR claim has been received, staff will review the claim for completeness and compliance with these rules and the provisions of Title 49, Chapter 16, Idaho Code. If the claim is complete and in compliance with statute and these rules, the ICAR Board will send notification per Section 49-1608F(5), Idaho Code, to the subject vehicle dealer with a demand that the dealer satisfy the judgement within thirty (30) days. (3-31-22)

a. Should the dealer fail to satisfy the judgment within thirty (30) days of notice from the ICAR Board, staff will provide the ICAR Board and the claimant a staff-recommended amount of the claim. If the claimant agrees with the staff-recommended payment amount, the ICAR Board will issue a final order either adopting or rejecting the staff recommended claim payment amount. (3-31-22)

b. Should the claimant disagree with the proposed amount to be paid on the claim, the claimant may request an administrative hearing under the provisions of Title 67, Chapter 52, Idaho Code, within 10 business days

of receipt of notification. The department will appoint a qualified hearing officer to hear the claim, take testimony and review evidence; and issue findings of fact, conclusions of law and provide a recommended order. (3-31-22)

c. Upon receipt of the recommended order from the hearing officer, the ICAR Board will issue a final order either adopting or rejecting the hearing officer's recommendation of the claim payment amount. (3-31-22)

d. Final orders of the ICAR Board may be subject to judicial review under the provision of Title 67, Chapter 52, Idaho Code. (3-31-22)

201. -- 299. (RESERVED)

~~300. PENALTIES:~~

~~A dealer violating this rule is subject to license suspension for a period not to exceed six (6) months. (3-31-22)~~

~~301. -- 999. (RESERVED)~~

IDAHA 39 – IDAHO TRANSPORTATION DEPARTMENT

39.02.75 – RULES GOVERNING NAMES ON DRIVERS' LICENSES AND IDENTIFICATION CARDS

DOCKET NO. 39-0275-2401

NOTICE OF RULEMAKING – PROPOSED RULE

AUTHORITY: In compliance with Section 67-5221(1), Idaho Code, notice is hereby given that this agency has initiated proposed rulemaking procedures. The action is authorized pursuant to Sections 49-201(1), 49-319(5), and 49-2444(15), Idaho Code.

PUBLIC HEARING SCHEDULE: Public hearing(s) concerning this rulemaking will be scheduled if requested in writing by twenty-five (25) persons, a political subdivision, or an agency, not later than October 16, 2024.

The hearing site(s) will be accessible to persons with disabilities. Requests for accommodation must be made not later than five (5) days prior to the hearing, to the agency address below.

DESCRIPTIVE SUMMARY: The following is a nontechnical explanation of the substance and purpose of the proposed rulemaking:

This rule provides standardization to record and format names for credentials. The proposed changes align the recording of an individual's name with their verified identity documentation and remove unnecessary and prohibitive language.

FEE SUMMARY: The following is a specific description of the fee or charge imposed or increased: N/A.

FISCAL IMPACT: The following is a specific description, if applicable, of any negative fiscal impact on the state General Fund greater than ten thousand dollars (\$10,000) during the fiscal year resulting from this rulemaking: N/A.

NEGOTIATED RULEMAKING: Pursuant to Section 67-5220(1), Idaho Code, negotiated rulemaking was conducted. The Notice of Intent to Promulgate Rules - Negotiated Rulemaking was published in the May 1, 2024, Idaho Administrative Bulletin, [Vol. 24-5, pages 236-237](#).

INCORPORATION BY REFERENCE: Pursuant to Section 67-5229(2)(a), Idaho Code, the following is a brief synopsis of why the materials cited are being incorporated by reference into this rule: N/A.

ASSISTANCE ON TECHNICAL QUESTIONS, SUBMISSION OF WRITTEN COMMENTS: For assistance on technical questions concerning the proposed rule, contact Brendan Floyd at 208-334-8474.

Anyone may submit written comments regarding this proposed rulemaking. All written comments must be directed to the undersigned and must be delivered on or before October 23, 2024.

DATED this 30th day of August, 2024.

Brendan Floyd
Policy Specialist
Idaho Transportation Department
11331 W. Chinden Blvd.
Boise, ID 83714
208-334-8474
Brendan.floyd@itd.idaho.gov

THE FOLLOWING IS THE PROPOSED TEXT OF DOCKET NO. 39-0275-2401
(Only Those Sections With Amendments Are Shown.)

39.02.75 – RULES GOVERNING NAMES ON DRIVERS' LICENSES AND IDENTIFICATION CARDS

001. ~~TITLE AND SCOPE~~ **PURPOSE.**

~~01. Title. This rule is titled IDAPA 39.02.75 "Rules Governing Names on Drivers' Licenses and Identification Cards," IDAPA 39, Title 02, Chapter 75.~~ (3-31-22)

~~02. Scope. The purpose of t~~ This rule ~~is to~~ provides procedures and criteria for County Sheriffs and the Idaho Transportation Department to record and format names, ~~and to allow surnames and hyphenated names~~ on drivers' licenses and identification cards. (3-31-22)()

002. -- 099. (RESERVED)

100. GENERAL PROVISIONS.

01. **Punctuation Marks.** The only punctuation marks which may be used in a name are ~~the comma (,); apostrophe ('); and the hyphen (-). A hyphen is allowed in the last name only, and may occur once. A comma can only be used between the last name and the first name~~ those allowed by the North American Card Design Standard. (3-31-22)()

02. **Full Name Requirements.** If a full name has more characters than the department automated system allows, the last name and first name must be written out fully. ~~The, and the~~ middle name can be initialized ~~and then the full middle name entered on the comment line of the application.~~ If there is a designator, it will follow the middle initial. If the name still has more characters than the department automated system allows, the first and middle names can be initialized ~~and the full first and middle names entered on the comment line of the application.~~ (3-31-22)()

101. -- 199. (RESERVED)

200. CRITERIA.

01. **Legal Name.** The name on the certified original birth certificate will be used unless a name changes due to: (3-31-22)

- a. Marriage; (3-31-22)
- b. Divorce; or (3-31-22)
- c. Court Order. (3-31-22)

~~02. Stepparents' Name. An applicant is not allowed to use a stepparent's last name, except by court order or other documents may be accepted to change a name, on approval by the Idaho Transportation Department.~~ (3-31-22)

~~03.~~ **Driver's License and Identification Card Names.** The name printed on the driver's license or identification card will be maintained in the Idaho Transportation Department records in the following order: (1) Last name, (2) First name, (3) Middle name, (4) Designator ~~(if applicable (see Subsection 200.04)).~~ An applicant may not have a driver's license and an identification card in different names. An applicant may add a middle name by providing a certified original copy of the applicant's: (3-31-22)()

- a. Birth Certificate; (3-31-22)
- b. Court Order; or (3-31-22)
- c. Divorce Decree. (3-31-22)

043. Designations of Names. The designations of I, II, III, etc., will become first (1st), second (2nd), third (3rd), etc., and will appear after the middle name. The designators of JR and SR (no periods allowed) will be permitted and will appear after the middle name. The JR and SR designators will be permitted only if there is proof that the other individual exists, by way of an original certified copy of a birth certificate. (3-31-22)

054. Married Applicant's Name. (3-31-22)

a. A married applicant is permitted ~~to use~~ to use either their birth last name or the birth last name of their spouse as the last name or as the middle name, or may hyphenate their current last name with their spouse's last name to form the last name. In no case ~~under any of these stated options shall~~ will any applicant have more than one (1) hyphen in their last name. (3-31-22)()

b. Married applicants may choose to use different hyphenated last names. (3-31-22)

c. Married applicants who choose to have the same hyphenated last name may hyphenate their last names in any order. (3-31-22)

d. Married applicants who already have hyphenated last names may: (3-31-22)

i. Use the hyphenated name of their spouse or retain their own hyphenated name; or (3-31-22)

ii. Combine part of their own hyphenated name and part of the hyphenated name of their spouse. (3-31-22)

e. An applicant who is established in department records with a hyphenated last name due to marriage and wants to drop the first part or the second part of the hyphenated name ~~must~~ will provide, ~~as required by the department,~~ the following: (3-31-22)()

i. A certified copy of a birth certificate; and/or (3-31-22)

ii. A certified copy of a marriage certificate; and/or (3-31-22)

iii. A certified copy of a divorce decree; and/or (3-31-22)

iv. A certified copy of a death certificate. (3-31-22)

065. Divorced Applicant's Name. A divorced applicant who wants to use their original birth last name, or a surname from a previous marriage, but does not have a divorce decree indicating the new name, is allowed to submit the following documents to the County Sheriff or the Idaho Transportation Department: (3-31-22)

a. Original certified copy of the birth certificate showing the original last name; or (3-31-22)

b. Original certified copies of the marriage certificate and the divorce decree, as evidence to change the name. (3-31-22)

076. Applicant's First Name. An applicant is not allowed to change their first name except by court order. (3-31-22)

087. Common Law Marriage. Common law marriages created prior to January 1, 1996 will, for the purposes of this rule, be treated as a valid marriage. An affidavit of agreement is required, which includes: (3-31-22)

- a. The signatures of both the husband and the wife; (3-31-22)
- b. The date they became married under common law; and (3-31-22)
- c. Other documents verifying the marriage (subject to the approval of the Idaho Transportation Department). (3-31-22)

098. Change of Name on Record. Once a name is established in the Idaho Transportation Department records, a court order, marriage license, or divorce decree will be required to change the name and record. (3-31-22)

409. Titles or Nicknames. An applicant is not allowed to use titles or nicknames. (3-31-22)

201. -- 299. (RESERVED)

300. PROCEDURES.

01. Verification of Name. First-time applicants for a driver's license or identification card ~~must~~ will provide the County Sheriff's issuing office with one (1) of the following in order to verify their name: (3-31-22)()

- a. Original certified copy of the birth certificate; (3-31-22)
- b. Court order; (3-31-22)
- c. Original certified copy of the marriage license; (3-31-22)
- d. Divorce decree (if applicable); (3-31-22)
- e. Driver's license from another state or country that is current or if expired, has been expired for less than five (5) years; or (3-31-22)
- f. A valid, unexpired passport. (3-31-22)

02. Surrendering Driver's License or Identification Card. Applicants for license or identification card renewals ~~must~~ or duplicates will surrender the previous driver's license or identification card. Name changes are allowed if the criteria in Section 200 are met. (3-31-22)()

~~**03. Surrendering Duplicate Driver's License or Identification Cards.** Applicants for duplicate drivers' licenses or identification cards must surrender the previous driver's license or identification card (if applicable). Name changes are allowed if the criteria in Section 200 are met. (3-31-22)~~

043. Document Approval by the Department. Other documents may be accepted to change a name, on approval by the Idaho Transportation Department. (3-31-22)

301. -- 999. (RESERVED)

IDAPA 39 – IDAHO TRANSPORTATION DEPARTMENT

39.03.41 – RULES GOVERNING TRAFFIC CONTROL DEVICES

DOCKET NO. 39-0341-2401

NOTICE OF RULEMAKING – PROPOSED RULE

AUTHORITY: In compliance with Section 67-5221(1), Idaho Code, notice is hereby given that this agency has initiated proposed rulemaking procedures. The action is authorized pursuant to Sections 40-312(1), 40-313(2), and 49-201(3), Idaho Code.

PUBLIC HEARING SCHEDULE: Public hearing(s) concerning this rulemaking will be scheduled if requested in writing by twenty-five (25) persons, a political subdivision, or an agency, not later than October 16, 2024.

The hearing site(s) will be accessible to persons with disabilities. Requests for accommodation must be made not later than five (5) days prior to the hearing, to the agency address below.

DESCRIPTIVE SUMMARY: The following is a nontechnical explanation of the substance and purpose of the proposed rulemaking:

Pursuant to 23 CFR § 655.603(a)(1) and (3), states are required to be in substantial conformance with the federal Manual on Uniform Traffic Control Devices (MUTCD) within two years of the effective date of the final rule (December 2023). This rule articulates the portions of the MUTCD that Idaho does not comply with.

FEE SUMMARY: The following is a specific description of the fee or charge imposed or increased: N/A.

FISCAL IMPACT: The following is a specific description, if applicable, of any negative fiscal impact on the state General Fund greater than ten thousand dollars (\$10,000) during the fiscal year resulting from this rulemaking: N/A.

NEGOTIATED RULEMAKING: Pursuant to Section 67-5220(1), Idaho Code, negotiated rulemaking was conducted. The Notice of Intent to Promulgate Rules - Negotiated Rulemaking was published in the July 3, 2024, Idaho Administrative Bulletin, [Vol. 24-7, pages 273-274](#).

INCORPORATION BY REFERENCE: Pursuant to Section 67-5229(2)(a), Idaho Code, the following is a brief synopsis of why the materials cited are being incorporated by reference into this rule:

Pursuant to the federal statute cited under the “Descriptive Summary,” all states must substantially conform to the federal Manual on Uniform Traffic Control Devices (MUTCD). Idaho Code 49-201(3) requires the Transportation Board to adopt a manual for a system of traffic control devices that conforms, so far as possible, with the specifications set forth in the MUTCD. This rule incorporates the MUTCD by reference and articulates the instances where Idaho does not fully comply with the manual, which is permissible under the “substantial conformance” provisions in CFR. Providing this material through administrative rule allows for stakeholder engagement and feedback throughout the review process.

ASSISTANCE ON TECHNICAL QUESTIONS, SUBMISSION OF WRITTEN COMMENTS: For assistance on technical questions concerning the proposed rule, contact Brendan Floyd at 208-334-8474.

Anyone may submit written comments regarding this proposed rulemaking. All written comments must be directed to the undersigned and must be delivered on or before October 23, 2024.

DATED this 30th day of August, 2024.

Brendan Floyd
Policy Specialist
Idaho Transportation Department
11331 W. Chinden Blvd.
Boise, ID 83714
208-334-8474
Brendan.floyd@itd.idaho.gov

THE FOLLOWING IS THE PROPOSED TEXT OF DOCKET NO. 39-0341-2401
(Only Those Sections With Amendments Are Shown.)

39.03.41 – RULES GOVERNING TRAFFIC CONTROL DEVICES

000. LEGAL AUTHORITY.

The Idaho Transportation Board adopts this rule under the authority of Section 40-312(1), Idaho Code, to meet the provisions of Sections 40-313(1) and 49-201(3), Idaho Code. (3-31-22)

001. ~~TITLE AND SCOPE~~**PURPOSE.**

~~01. Title. This rule is titled IDAPA 39.03.41, “Rules Governing Traffic Control Devices,” IDAPA 39, Title 03, Chapter 41.~~ (3-31-22)

~~02. Scope. It is the purpose of t~~This rule ~~to~~ establish~~s~~ standards, guidance, options, and supporting information for the design, construction, and implementation of traffic control devices. (3-31-22)()

002. – 003. (RESERVED)

004. INCORPORATION BY REFERENCE.

The “Manual on Uniform Traffic Control Devices for Streets and Highways” is published by the Federal Highway Administration of the U.S. Department of Transportation. The ~~2009 11th~~ edition ~~including revisions 1 and 2~~ of the Manual with an effective date of ~~June 13, 2012~~ **January 18, 2024**, is hereby incorporated by reference and made a part of the Rules of the Idaho Transportation Department. The following conforming additions to the Manual are adopted by the Idaho Transportation Board: (3-31-22)()

~~01. Section 1A.10, Interpretations, Experimentations, Changes, and Interim Approvals. On page 7, delete paragraphs 19 and 20.~~ (3-31-22)

~~021. Section 1A.1105, Relation to Other Documents.~~ (3-31-22)()

a. On page ~~73~~, replace paragraph 01 as follows:

01 To the extent that they are incorporated by specific reference, the latest editions of the following publications, ~~or those editions specifically noted~~, shall be a part of this Manual: “Standard Highway Signs ~~and Markings” book publication~~, the Idaho Transportation Department Supplement to the “Standard Highway Signs ~~and Markings” book publication~~; and “Color Specifications for Retroreflective Sign and Pavement Marking Materials” (appendix to subpart F of Part 655 of Title 23 of the Code of Federal Regulations).

(3-31-22)()

~~b. Add the following to the end of paragraph 04:~~

~~43. “Standards and Procedures for Specific Service Signs,” 20XX Edition (ITD)
44. “Standards and Procedures for Tourist Oriented Directional Signs (TODS) for Motorist Services Facilities Along the State Highway System Except Fully Controlled Access Highways,” 20XX Edition (ITD)~~

(3-31-22)

~~03:~~ **02. Section 1B.02 State Adoption and Conformance.** On page 4, insert the following after paragraph

04: Photo enforcement is not used in Idaho. All signs, pavement markings, signals, and other traffic control devices pertaining exclusively to photo enforcement in this manual are not applicable in Idaho and shall not be used.

05: High-occupancy vehicle lanes are not used in Idaho. All signs, pavement markings, signals, and other traffic control devices pertaining exclusively to high-occupancy vehicle lanes in this manual are not applicable in Idaho and shall not be used.

06: Light rail transit is not used in Idaho. All signs, pavement markings, signals, and other traffic control devices pertaining exclusively to light rail transit in this manual are not applicable in Idaho and shall not be used.

07: Toll facilities and priced managed lanes are not used in Idaho. All signs, pavement markings, signals, and other traffic control devices pertaining exclusively to toll facilities and/or priced managed lanes are not applicable in Idaho and shall not be used.

()

03. Section 1B.06 Changes to the MUTCD. On page 9, paragraph 04, replace the phrase “future for consideration in the next rulemaking” with “future rulemaking.” ()

04. Section 1B.07 Interim Approvals. On page 11, delete paragraph 11. ()

05. Section 1C.02 Definitions of Words and Phrases Used in this Manual. On page 17, add the following to definition 77:

Where used in Idaho Code, the terms “traffic engineering study,” “traffic study,” “engineering and traffic investigation,” “engineering or traffic investigation,” and “engineering and traffic study” shall mean the same as “engineering study.”

()

~~036. Table 2B-1. Regulatory Sign and Plaque Sizes.~~ On page 46, remove R1-5b, “Stop Here for Peds,” R1-5c, “Stop Here for Pedestrians,” R1-6a, and R1-9a. (3-31-22)()

a. On page 68, delete line 8. ()

b. On page 68, line 9, delete “(Stop Here for)” from the first column and delete “.5e” from the second column. ()

c. On page 68, line 10, delete “(Stop)” from the first column and delete “.6a” from the second column. ()

d. On page 68, line 11, delete “(Stop)” from the first column and delete “.6e” from the second column. ()

e. On page 68, line 12, delete “(Stop)” from the first column and delete “.9a” from the second column. ()

f. On page 68, line 16, add “.201P” after “2P.” ()

g. On page 68, delete lines 17, 18 and 28. ()

h. On page 72, line 7, replace “All-Terrian” with “All-Terrain.” ()

i. On page 73, line 18, replace “R13-1” with “R13-101;” replace both instances of “72 x 54” with “108 x 48;” replace “96 x 72” with “144 x 60;” and replace “132 x 90” with “180 x 84.” ()

j. On page 73, after the “Weight Limit” (R12-5) sign, insert a “Trailer Length Limit” sign with “R12-501” in the Sign Designation column, “2B.64” in the Section column, and “60 x 42” in each of the Conventional Road columns. ()

k. On page 73, to the bottom of the table, add a “Chains Required on Non-Exempt Commercial Vehicles” sign with “R16-201” in the Sign Designation column, “2B.69a” in the Section column, “132 x 72” in both Conventional Road columns and the Freeway column. ()

07. **Section 2B.10 Yield Control.** On page 77, replace paragraph 02 as follows:

02 Yield control should be considered when engineering judgment indicates that all of the following conditions exist:

A. Intersection sight distance is adequate on the approaches to be controlled by YIELD signs.

B. All approaches to the intersection are a single lane and there are no separate turn lanes.

C. One of the following crash-related criteria applies:

1. For changing from no intersection control to yield control, there have been two or more reported crashes in the previous 12 months that are susceptible to correction by the installation of a YIELD sign.

2. For changing from minor road stop control to yield control, there have been two or fewer reported crashes in the previous 12 months.

D. The combined motor vehicle, bicycle, and pedestrian volume entering the intersection averages less than 1,800 units per day or 140 units in the peak hour.

E. The angle of intersection is between 90 and 75 degrees.

F. The functional classification of the intersecting streets is either the intersection of two local streets or the intersection of a local street with a collector street.

()

048. **Section 2B.149. Yield Here To Pedestrians Signs and Stop Here For Pedestrian Signs (R1-5 Series).** On page 5481 delete “and Stop Here For Pedestrian” from the title. Replace the Section with the following:

Section 2B.19 Yield Here To Pedestrians Signs (R1-5 Series)

Support:

01 The R1-5 series signs are intended to mitigate the scenario that can place pedestrians at risk by blocking other drivers' view of pedestrians and by blocking the pedestrians' view of the vehicles approaching in the adjacent lanes.

02 State law requires drivers to yield to a pedestrian in an uncontrolled crosswalk.

Standard:

043 Yield Here To Pedestrians (R1-5, R1-5a, and R1-5d) signs (see Figures 2B-2 and 7B-1) shall be used if yield lines are used in advance of a marked crosswalk that crosses an uncontrolled multi-lane approach. The legend Stop Here For Pedestrians shall not be used. **The legend STATE LAW shall not be displayed on the R1-5 series signs.**

Support:

02 Idaho law requires drivers to yield to a pedestrian in an uncontrolled crosswalk.

Guidance:

034 If yield lines and Yield Here To Pedestrian signs are used in advance of a crosswalk that crosses an uncontrolled multi-lane approach, they should be placed 20 to 50 feet in advance of the nearest crosswalk line (see Section 3B.169 and Figure 3B-176), and parking should be prohibited in the area between the yield line and the crosswalk.

04 Yield lines and Yield Here To Pedestrian signs should not be used in advance of crosswalks that cross an approach to or departure from a roundabout.

Standard:

05 When used with a School Crossing assembly within school zones (see Part 7), the R1-5a sign shall be used in place of the R1-5 sign in accordance with Paragraph 03 of this Section.

06 When used with a Trail Crossing assembly (see Section 2C.54), the R1-5d sign shall be used in place of the R1-5 sign in accordance with Paragraph 03 of this Section.

Guidance:

07 When Yield Here to Pedestrians signs are provided in advance of a crosswalk across a multi-lane approach, parking should be prohibited in the area between the yield line and the crosswalk.

08 Yield lines and Yield Here To Pedestrian signs should not be used in advance of crosswalks that cross an approach to or departure from a roundabout.

Option:

059 Yield Here To Pedestrian signs may be used in advance of a crosswalk that crosses an uncontrolled multi-lane approach to indicate to road users where to yield **accordance with Paragraphs 03 through 05 of this Section** even if yield lines are not used.

0610 A Pedestrian Crossing (W11-2) warning sign may be placed overhead or may be post-mounted with a diagonal downward pointing arrow (W16-7P) plaque at the crosswalk location where Yield Here To Pedestrian signs have been installed in advance of the crosswalk.

07 ~~The legend STATE LAW may be displayed at the top of the R1-5 and R1-5a signs.~~

Standard:

0811 If a W11-2 sign has been post-mounted at the crosswalk location where a Yield Here To Pedestrians sign is used on the approach, the Yield Here To Pedestrian sign shall not be placed on the same post as or block the road user's view of the W11-2 sign.

Section 2B.19 Yield Here To Pedestrians Signs (R1-5 Series)

Option:
~~0912~~ An advance Pedestrian Crossing (W11-2) warning sign with an AHEAD or a distance supplemental plaque may be used in conjunction with a Yield Here To Pedestrians sign on the approach to the same crosswalk.
~~1013~~ In-Street Pedestrian Crossing signs and Yield Here To Pedestrian signs may be used together at the same crosswalk.

(3-31-22)()

~~059.~~ Section 2B.~~120~~, In-Street and Overhead Pedestrian and Trail Crossing Signs (R1-6, ~~R1-6a~~, ~~R1-9~~, and R1-9a Series).

(3-31-22)()

a. On page ~~5581~~ delete R1-6a and R1-9a from the title. R replace paragraph 01 as follows:

Option:
01 The In-Street Pedestrian Crossing (R1-6) sign (see Figure 2B-2) ~~or, In-Street Trail Crossing (R1-6d) sign (see Figure 2B-2), the Overhead Pedestrian Crossing (R1-9) sign (see Figure 2B-2), or the Overhead Trail Crossing (R1-9d) sign (see Figure 2B-2)~~ may be used to remind road users of laws regarding right-of-way at an unsignalized pedestrian crosswalk. The legend STATE LAW may be displayed at the top of the R1-6 and R1-9 signs. On the R1-6 sign, the legend YIELD may be used instead of the appropriate YIELD sign symbol.

(3-31-22)()

b. On page ~~5683~~, replace paragraphs ~~08 and 09~~ and add paragraph ~~09a~~ 03 as follows:

~~Standard:~~
~~08 The In-Street Pedestrian Crossing sign and the Overhead Pedestrian Crossing sign shall not be used at crosswalks on approaches controlled by a traffic control signal, pedestrian hybrid beacon, or an emergency vehicle hybrid beacon.~~
~~093 The legend STOP FOR PEDESTRIANS legend shall not be used on In-Street Pedestrian Crossing signs or Overhead Pedestrian Crossing signs.~~
~~Support:~~
~~09a Idaho law requires drivers to yield to a pedestrian in an uncontrolled crosswalk.~~

(3-31-22)()

c. On page ~~5683~~, add paragraph ~~H~~06a as follows:

~~11a The In-Street Pedestrian Crossing sign or the Overhead Pedestrian Crossing sign may be used at intersections or midblock pedestrian crossings with flashing beacons.~~
~~Support:~~
~~06a State law requires drivers to yield to a pedestrian in an uncontrolled crosswalk.~~

(3-31-22)()

~~d.~~ On page 56, replace paragraph 15 as follows:

~~15 In-Street Pedestrian Crossing signs, Overhead Pedestrian Crossing signs, and Yield Here To Pedestrian signs may be used together at the same crosswalk.~~

(3-31-22)

0610. **Figure 2B-2. Unsignalized Pedestrian Crosswalk Signs.** On page ~~55~~82, delete signs R1-5b, R1-5Ce, R1-6a, ~~R1-6e,~~ and R1-9a, ~~and R1-9e.~~ (3-31-22)()

07. ~~Section 2B-69, SLOW AND MOVE OVER FOR STOPPED VEHICLES WITH FLASHING LIGHTS (R16-101) sign.~~ On page 102, add the following section:

<p>Support: 01 State law requires drivers approaching stationary police, emergency, tow truck, or highway incident response vehicles to slow on two-lane highways and to slow and move over on multi-lane highways.</p> <p>Option: 02 The SLOW AND MOVE OVER FOR STOPPED VEHICLES WITH FLASHING LIGHTS (R16-101) sign (see Figure 2B-33) may be used to inform road users of the state law on multi-lane highways.</p> <p>Standard: 03 If used, the SLOW AND MOVE OVER FOR STOPPED VEHICLES WITH FLASHING LIGHTS sign shall only be used on highways with two or more lanes in each direction.</p> <p>Option: 04 The legend STATE LAW may be displayed at the top of the SLOW AND MOVE OVER FOR STOPPED VEHICLES WITH FLASHING LIGHTS sign.</p> <p>Standard: 05 If used, the legend STATE LAW shall be black with a black border on a yellow background.</p>

(3-31-22)

08. **Figure 2B-33. Slow and Move Over for Stopped Vehicles with Flashing Lights Sign.** On page 102, add the following figure:

Figure 2B-33. Slow And Move Over For Stopped Vehicles With Flashing Lights Sign

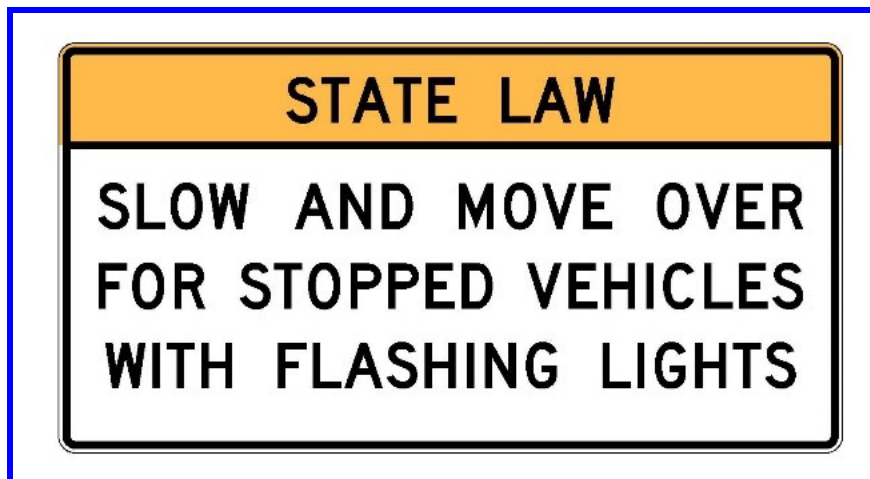

(3-31-22)

11. **Section 2B.21 Speed Limit Sign (R2-1).** On page 85, paragraph 18, replace the phrase “Traffic Control Device Handbook” with “ITE Traffic Control Device Handbook – 2nd Edition, 2013.” ()

12. **Figure 2B-3. Speed Limit Signs and Plaques.** On page 86, delete signs R2-2aP, R2-2bP, R2-2cP, R2-6aP, and R2-10 and add the following sign:



R2-201P

()

13. Section 2B.22 Vehicle Speed Limit Plaques (R2-2P Series). On page 87:

()

a. Replace paragraph 01 with the following:

01 Where a special speed limit applies to trucks, the Truck Speed Limit (R2-2P) plaque shall be displayed below the Speed Limit (R2-1) sign, except as provided in Paragraph 2 of this Section.

()

b. Replace paragraph 03 with the following:

03 A 5 AXLES OR MORE OVER 13 TONS (R2-201P) plaque (see Figure 2B-3) may be used beneath the Truck Speed Limit Plaque (R2-2P) to reiterate the statutory definition of trucks.

()

14. Section 2B.25 Higher Fines Signs and Plaque (R2-6P, R2-10, and R2-11). On pages 87-88, replace the section with the following:

Section 2B.25 Higher Fines Sign and Plaque (R2-6P and R2-11)

Standard:

01 Except as provided in Paragraph 3 of this Section, if increased fines are imposed for traffic violations within a designated zone of a roadway, a FINES HIGHER (R2-6P) plaque (see Figure 2B-3) shall be used to provide notice to road users.

02 If an R2-6P plaque is posted to provide notice of increased fines for traffic violations, an END HIGHER FINES ZONE (R2-11) sign (see Figure 2B-3) shall be installed at the downstream end of the zone to provide notice to road users of the termination of the increased fines zone.

Guidance:

03 The FINES HIGHER plaque should be located at the beginning of the temporary traffic control zone and just beyond any interchanges, major intersections, or other major traffic generators.

Section 2B.25 Higher Fines Sign and Plaque (R2-6P and R2-11)

Standard:

04 The Higher Fines signs and plaque shall have a black legend and border on a white rectangular background. All supplemental plaques mounted below the Higher Fines signs and plaque shall have a black legend and border on a white rectangular background.

05 The FINES HIGHER plaque shall be mounted below an applicable regulatory or warning sign in a temporary traffic control zone (see Section 6G.08), a school zone (see Section 7B.06), or other applicable designated zone.

Option:

06 The legend FINES HIGHER on the R2-6P plaque may be replaced by \$XX FINE (R2-6bP), or another legend appropriate to the specific regulation (see Figure 2B-3).

07 The following, listed in order of preference, may be mounted below an R2-6P plaque:

A. A WHEN FLASHING (S4-4P) plaque (see Figure 7B-1) if used in conjunction with a Speed Limit Sign Beacon (see Section 4S.04), or

B. A TIME OF DAY (S4-1P) plaque (see Figure 7B-1) specifying the times that the higher fines are in effect, if supplemented by an S4-6P plaque indicating the days of the week the higher fines are in effect, or

C. A WHEN CHILDREN ARE PRESENT (S4-2P) plaque (see Figure 7B-1), if supplemented by an S4-6P plaque indicating the days of the week the speed limit is in effect.

()

15. **Road Closed, Weight Limit, and Trailer Length Limit Signs.** On page 136, change the heading at the top of the page to “**ROAD CLOSED, WEIGHT LIMIT AND TRAILER LENGTH LIMIT SIGNS.**”

()

16. **Figure 2B-30. Road Closed and Weight Limit Signs.** On page 136, change the figure title to “**Figure 2B-30. Road Closed, Weight Limit and Trailer Length Limit Signs**” and add the following sign:

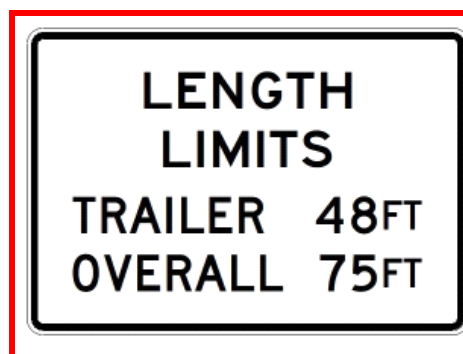

R12-501

()

17. **Section 2B.64 Weight Limit Signs (R12-1 through R12-7).** On page 137, change the section title to “**Section 2B.64 Weight Limit and Trailer Length Limit Signs (R12-1 through R12-7 and R12-501)**” and add paragraph 07a as follows:

07a A TRAILER LENGTH LIMIT (R12-501) sign (see Figure 2B-30) may be used in advance of highways with length restrictions.

()

18. Section 2B.65 Weigh Station Sign (R13-1). On page 138, change the sign designation in the section title to “R13-101” and replace paragraphs 01 and 02 with the following:

Guidance:

01 An R13-101 sign with the legend COMMERCIAL – FARM TRUCKS OVER 13 TONS HAZMAT OVER 5 TONS NEXT RIGHT (LEFT) (see Figure 2B-31) should be used to direct appropriate traffic into an inspection station.

02 The R13-101 sign should be supplemented by the D8 series of guide signs (see Section 2D.51).

()

19. Figure 2B-31. Truck Signs. On page 139, replace the R13-1 sign with the following:

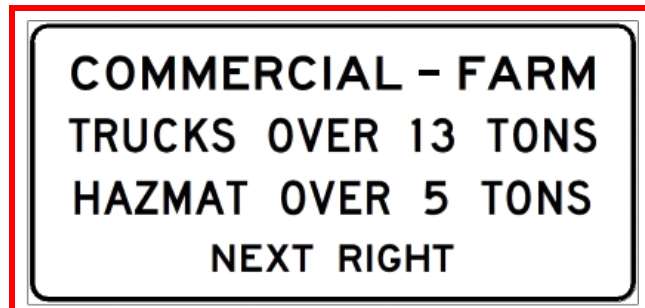

R13-101

()

20. Succeeding Section 2B.69. On page 140, after Section 2B.69, add a new section as follows:()

09- Section 2B.70, CHAINS REQUIRED ON NON-EXEMPT COMMERCIAL VEHICLES (R16-201) sign. On page 102, add the following section:

Section 2B.69a. CHAINS REQUIRED ON NON-EXEMPT COMMERCIAL VEHICLES (R16-201) sign

Standard:

01 When required by state law, CHAINS REQUIRED ON NON-EXEMPT COMMERCIAL VEHICLES (R16-201) signs (see Figure 2B-34) shall be installed ~~when mountain passes are determined to be unsafe by the Idaho Transportation Department. If used,~~ two or more CHAINS REQUIRED ON NON-EXEMPT COMMERCIAL VEHICLES signs shall be installed in advance of an area that has been provided for drivers to pull off of the highway to install chains on their tires (see Section 2I.07).

Section 2B.69a. CHAINS REQUIRED ON NON-EXEMPT COMMERCIAL VEHICLES (R16-201) sign

Support:

- 02 Commercial vehicles required to use chains include:
- Vehicles with a combined weight in excess of 26,000 pounds including a trailer with a rating of more than 10,000 pounds
 - Vehicles with weight in excess of 26,000 pounds
- 03 Commercial vehicles exempt from chain requirements include:
- Idaho Transportation Department vehicles used in the maintenance of the highway
 - School busses or other vehicles used to transport school children and teachers
 - Vehicles used by farmers to transport agricultural products, supplies, or farm equipment
 - Mail carrier vehicles
 - Motor carriers transporting forest products or chips
 - Motor carriers transporting mining products including sand, gravel, and aggregates, but not petroleum products
 - Tow trucks

Standard:

04 The CHAINS REQUIRED ON NON-EXEMPT COMMERCIAL VEHICLES signs shall be removed or covered when the condition no longer applies.

05 The CHAINS REQUIRED ON NON-EXEMPT COMMERCIAL VEHICLES sign shall have a black legend and border on a white background.

Option:

06 The legend STATE LAW may be displayed at the top of the CHAINS REQUIRED ON NON-EXEMPT COMMERCIAL VEHICLES sign.

Standard:

07 If used, the legend STATE LAW shall be black with a black border on a yellow background.

(3-31-22)

~~10. Figure 2B-34. Chains Required on Non-Exempt Commercial Vehicles Sign.~~ On page 102, add the following figure:

Figure 2B-34~~2~~. Chains Required On Non-Exempt Commercial Vehicles Sign



R16-201

(3-31-22)()

11. Section 2D-43, Street Name Signs (D3-1 or D3-1a). (3-31-22)

a. On page 162, change the fifteenth paragraph under the Option statement to read as follows: The border may be omitted from a Street Name sign except on State Highways. (3-31-22)

12. Table 2E-1, Freeway or Expressway Guide Sign and Plaque Sizes. On page 186, replace the first 16 lines of the table with the following:

Sign or Plaque	Sign Designation	Section	Minimum Size
Exit Number (plaque)			
1-, 2-Digit Exit Number	E1-5P	2E-31	414 x 36
3-Digit Exit Number	E1-5P	2E-31	432 x 36
1-, 2-Digit Exit Number (with single letter suffix)	E1-5P	2E-31	438 x 36
3-Digit Exit Number (with single letter suffix)	E1-5P	2E-31	456 x 36
1-, 2-Digit Exit Number (with dual letter suffix)	E1-5P	2E-31	468 x 36
3-Digit Exit Number (with dual letter suffix)	E1-5P	2E-31	486 x 36
Left (plaque)	E1-5aP	2E-33	72x36
Left Exit Number (plaque)			
1-, 2-Digit Exit Number	E1-5bP	2E-31	414 x 60
3-Digit Exit Number	E1-5bP	2E-31	432 x 60
1-, 2-Digit Exit Number (with single letter suffix)	E1-5bP	2E-31	438 x 60
3-Digit Exit Number (with single letter suffix)	E1-5bP	2E-31	456 x 60
1-, 2-Digit Exit Number (with dual letter suffix)	E1-5bP	2E-31	468 x 60
3-Digit Exit Number (with dual letter suffix)	E1-5bP	2E-31	486 x 60

(3-31-22)

13. Section 2E-31, Interchange Exit Numbering. On page 212, substitute the following for the fourth sentence of paragraph 04: “The exit number plaque (E1-5P) (see Figure 2E-22) shall be thirty-six (36) inches in height and shall include the word “EXIT” along with the appropriate exit number.” (3-31-22)

21. Table 2C-1, Warning Sign and Plaque Sizes. ()

a. On page 149, after the “Bridge Ices Before Road” (W8-13) sign, insert a “Chains Recommended When Icy” sign with “W8-1301” in the Sign Designation column, “2C.30” in the Section column, “30 x 30” in the Conventional Road Single Lane column, “36 x 36” in the Conventional Road Multi-Lane column, and “48 x 48” in the Expressway and Freeway columns. ()

b. On page 150, after the “Ahead (plaque)” (W16-9P) plaque, insert an “Open Range” plaque with “W16-901P” in the Sign Designation column, “2C.57” in the Section column, and “30 x 24” in all road type columns. ()

22. Figure 2C-2, Examples of Warning Signs for Changes in Horizontal Alignment (Sheet 1 of 2). On page 156: ()

a. Replace the “30 MPH” legends for signs W13-1P and W13-1aP with “35 MPH.” ()

b. Replace “30-mph” in Note 4 with “35-mph.” ()

23. Section 2C.12 Advisory Exit and Ramp Speed Signs (W13-2 and W13-3) and Combination Horizontal Alignment/Advisory Exit and Ramp Speed Signs (W13-6 through W13-13). On page 160, add the word “Speed” after the words “Alignment/Advisory Exit” in the second sentence of paragraph 09. ()

24. Section 2C.57 Use of Supplemental Warning Plaques. On page 195, add the following after paragraph 03:

<p><u>Option:</u></p> <p>04 <u>The OPEN RANGE (W16-901P) plaque (see Figure 2C-16) may be used with the Cattle (W11-4) or Sheep (W11-17) Non-Vehicular Warning signs.</u></p> <p><u>Support:</u></p> <p>05 <u>Open range is defined as “all unenclosed lands outside of cities, villages and herd districts, upon which by custom, license, lease, or permit are grazed or permitted to roam.”</u></p> <p><u>Guidance:</u></p> <p>06 <u>Use of the OPEN RANGE plaque should be limited to areas defined in paragraph 05 of this section.</u></p>
--

25. Figure 2C-16. Supplemental Warning Plaques. On page 195, add the following sign:



26. Section 2D.03 Size of Signs. On page 206, add “The dimensions of signs on extruded aluminum substrate may be increased to the nearest increment of 12 inches.” to the end of paragraph 03. ()

27. Table 2D-1. Conventional Road Guide Sign and Plaque Sizes. On page 208, add a Slow Vehicle Turn Out sign with “D17-701” in the Sign Designation column, “2D.54” in the Section column, “72 x 36” in the Conventional Road column, and “96 x 60” in the Oversized column to the bottom of the table. ()

28. Table 2D-2. Recommended Minimum Letter and Numeral Sizes for Conventional Road Guide Signs According to Speed* (Sheet 2 of 2) B - Overhead-Mounted Signs. On page 211, replace the text “Interstate, U.S., State, or Off-Interstate Business Route Signs” with the text “Interstate or Off-Interstate.” ()

29. Figure 2D-2. Examples of Uses of Abbreviations on Guide Signs. On page 212, change the sentence that reads ““South” is a cardinal direction and may be abbreviated.” to ““South” is a pre-directional designation and may be abbreviated.” ()

30. Section 2D.08 Arrows. On page 215, replace the reference to “Section 2D.41” in paragraph 25

with “Section 2E.41.” ()

31. Section 2D.25 Temporary Detour Signs and Auxiliary Plaques. On page 221, replace paragraph 01 with the following:

01 Chapters 6H and 6I contain information regarding Temporary Detour signs and auxiliary plaques.

32. Section 2D.51 WEIGH STATION Signing (D8 Series). On page 261: ()

a. Replace the “D8-1” sign references in paragraph 07 with the words “D8-1 Series.” ()

b. Replace paragraph 05 with the following:

05 A Weigh Station (R13-101) regulatory sign (see Section 2B.65) may be located following the Advance Weigh Station Ahead sign (see Figure 2D-23).

33. Figure 2D-23. Example of Weigh Station Signing – Conventional Road. On page 262, replace the R13-1 sign with an R13-101 sign and delete the double asterisk and associated note. ()

34. Section 2D.54 Emergency and Slow Vehicle Turn-Out Signs (D17-5 through D17-7). On page 266, add a new paragraph 02a as follows:

02a In addition to the SLOW VEHICLE TURN-OUT (D17-7) sign, a SLOW VEHICLE TURN-OUT (D17-701) sign with a directional arrow (see Figure 2D-28) may be used immediately before the turn-out.

35. Figure 2D-28. Emergency and Slow Vehicle Turn-Out Signs. On page 266, add the following sign:



36. Section 2E.12 Size of Signs and Letters. On page 293, add “The dimensions of signs on extruded aluminum substrate may be increased to the nearest increment of 12 inches.” to the end of paragraph 03. ()

37. Section 2E.54 Weigh Station Signing. On page 370, replace paragraph 05 with the following:

~~05 A Weigh Station (R13-101) regulatory sign (see Section 2B.65) may be added to the sign sequence as shown in Figure 2E-59.~~

()

~~38. Figure 2E-59. Example of Weigh Station Signing on Freeways. On page 372, replace the R13-1 sign with an R13-101 sign and delete the associated note.~~

()

~~39. Section 2I.03 General Service Signs for Freeways and Expressways. On page 482, remove the bold font from paragraph 26 to indicate an Option statement.~~

()

~~1440. Section 2M.10, Memorial or Dedication Signing. On page 339, replace the section with the following:~~

Support:

~~01 Legislative bodies will occasionally adopt an act or resolution memorializing or dedicating a highway, bridge, or other component of the highway. State law identifies the following as memorial highways or bridges in Idaho:~~

- ~~• Bennett Bay Bridge on I-90 as the “Veterans Memorial Centennial Bridge.”~~
- ~~• US-93 bridge over the Snake River as the “I.B. Perrine Bridge.”~~
- ~~• US-95 between Midvale and Cambridge as the “Stu Dopf Memorial Highway.”~~
- ~~• I-90 as the Purple Heart Trail~~
- ~~• SH-3 as the “North Idaho Medal of Honor Highway.”~~
- ~~• I-84 as the “Vietnam Veterans Memorial Highway.”~~
- ~~• US-20 as the “Idaho Medal of Honor Highway.”~~
- ~~• US-26 as the “POW/MIA Memorial Highway.”~~
- ~~• SH-6 between US-95 and the western city limits of the city of Potlatch as the “Bobby Chambers Memorial Highway.”~~

Guidance:

~~02 Except as provided in Paragraphs 03 and 04, memorial or dedication names should not appear on or along a highway, or be placed on bridges or other highway components. If a route, bridge, or highway component is officially designated as a memorial or dedication, and if notification of the memorial or dedication is to be made on the highway right-of-way, such notification should consist of installing a memorial or dedication marker in a rest area, scenic overlook, recreational area, or other appropriate location where parking is provided with the signing inconspicuously located relative to vehicle operations along the highway.~~

Option:

~~03 If the installation of a memorial or dedication marker off the main roadway is not practical, memorial or dedication signs may be installed on the mainline.~~

Guidance:

~~04 Except as provided in paragraphs 06 and 07, freeways and expressways should not be signed as memorial or dedicated highways.~~

Standard:

~~05 Where memorial or dedication signs are installed on the mainline, (1) memorial or dedication names shall not appear on directional guide signs, (2) memorial or dedication signs shall not interfere with the placement of any other necessary signing, and (3) memorial or dedication signs shall not compromise the safety or efficiency of traffic flow. Except as provided in paragraph 07, the memorial or dedication signing shall be limited to one sign at an appropriate location in each route direction, each as an independent sign installation. Sign location shall be determined by engineering judgement.~~

~~06 Memorial or dedication signs shall be installed for the Veterans Memorial Centennial Bridge, I-B Perrine Bridge, and North Idaho Medal of Honor Highway.~~

~~07 The Purple Heart Trail, Vietnam Veterans Memorial Highway, and Idaho Medal of Honor Highway shall have memorial or dedication signs installed at each end of the highway and at intermediate locations along the highway.~~

Guidance:

~~08 Memorial or dedication signs should have a white legend and border on a brown background.~~

Standard:

~~09 Memorial or dedication signs shall be rectangular in shape. The legend displayed on memorial or dedication signs shall be limited to the name of the person or entity being recognized and a simple message preceding or following the name, such as "Dedicated to" or "Memorial Parkway." Additional legend, such as biographical information, shall not be displayed on memorial or dedication signs. Except as provided in paragraph 10, decorative or graphical elements, pictographs, logos, or symbols shall not be displayed on memorial or dedication signs. All letters and numerals displayed on memorial or dedication signs shall be as provided in the "Standard Highway Signs and Markings" book (see Section 1A.11). The route number or officially mapped name of the highway shall not be displayed on the memorial or dedication sign~~

~~10 The design of the Idaho Medal of Honor Highway sign shall include three different designs of the medal of honor.~~

Option:

~~11 The lettering for the name of the person or entity being recognized may be composed of a combination of lower case letters with initial upper case letters.~~

Standard:

~~12 Memorial or dedication names shall not appear on supplemental signs or on any other information sign on or along the highway or its intersecting routes.~~

Support:

~~13 Named highways are officially designated and shown on official maps and serve the purpose of providing route guidance, primarily on unnumbered highways. A highway designated as a memorial or dedication is not considered to be a named highway. Section 2D-53 contains provisions for the signing of named highways.~~

(3-31-22)()

~~15. Section 2J.11, Signing Policy. On page 319, add the following after paragraph 01:~~

Support:

~~01a The Idaho Transportation Department's specific service signs policy can be found in "Standards and Procedures for Specific Service Signs" (see Section 1A.11).(X XX 19)~~

(3-31-22)

~~16. Section 2K.07, State Policy. On page 324, add the following after paragraph 02:~~

Support:

03 The Idaho Transportation Department's tourist-oriented directional signing policy can be found in "Standards and Procedures for Tourist-Oriented Directional Signs (TODS) for Motorist Services Facilities Along the State Highway System Except Fully Controlled Access Highways" (see Section 1A.11).

(3-31-22)

~~17. Section 4D.04, Meaning of Vehicular Signal Indications.~~ On page 451 in the second paragraph of Item C.1, substitute the following for the first sentence: "Except when a traffic control device is in place prohibiting a turn on red or a steady RED ARROW signal indication is displayed, vehicular traffic facing a steady CIRCULAR RED signal indication is permitted to enter the intersection to turn right or turn left from a one-way or two-way street into a one-way street, after stopping." (3-31-22)

~~18. Table 6F-1, Temporary Traffic Control Zone Sign and Plaque Sizes.~~ On page 578, remove R2-6aP, "Begin Higher Fines Zone," R2-6bP, "Fines Double (plaque)," and R2-10, "\$XX Fine (plaque)." (3-31-22)

41. Section 3B.01 Yellow Center Line Pavement Markings. On page 540: ()

a. Change the word "Guidance" between paragraphs 06 and 07 to "Support." ()

b. Remove the italics from paragraph 07 to indicate a Support statement. ()

c. Insert the header "Guidance" between paragraphs 07 and 08. ()

42. Section 3B.05 Pavement Markings for Two-Way Left-Turn Lanes. On page 546, change paragraph 06 to read: "Two-way left-turn lane markings should not extend to intersections (see definition in Section 1C.02) controlled by a highway traffic signal." ()

43. Section 3B.17 Raised Pavement Markers Substituting for Pavement Markings. On page 572, change "Section 6J.02" in paragraph 04 to "Section 6J.03." ()

44. Figure 4C-7, Warrant 4, Pedestrian Four-Hour Volume (70% Factor). On page 659, change the subheading below the figure title to "(COMMUNITY LESS THAN 10,000 POPULATION OR ABOVE 35 MPH ON MAJOR STREET)." ()

45. Figure 4C-8, Warrant 4, Pedestrian Peak Hour (70% Factor). On page 659, change the subheading below the figure title to "(COMMUNITY LESS THAN 10,000 POPULATION OR ABOVE 35 MPH ON MAJOR STREET)." ()

46. Section 4F.02 Signal Indications for Left-Turn Movements – General. On page 684, delete paragraph 09. ()

47. Section 4F.09 Signal Indications for Right-Turn Movements – General. On page 693, delete paragraph 07. ()

48. Section 4F.16 Signal Indications for Approaches with No Through Movement. On page 707, delete item B of paragraph 11. ()

49. Section 4J.02 Design of Pedestrian Hybrid Beacons. On page 729, remove the word "STEADY" from paragraph 08. ()

50. Section 4U.02 In-Roadway Warning Lights at Crosswalks. On page 757, insert paragraph number 02a at the beginning of the line following paragraph 02. ()

~~49~~51. Figure 6FG-31, Regulatory Signs and Plaques in Temporary Traffic Control Zones. ()

a. On page ~~587~~794, ~~remove figures delete plaque~~ R2-6aP, ~~R2-6bP~~, and ~~signs~~ R2-10 and R2-12. ~~(3-31-22)~~()

b. On page 795, add the following sign:

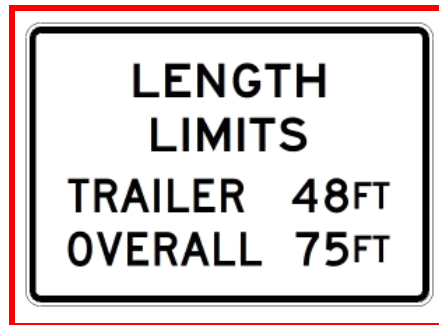

R12-501

()

52. Section 6G.06 Weight Limit Signs (R12-1, R12-2, and R12-5). On page 795, change the section title to “Section 6G.06 Weight Limit and Trailer Length Limit Signs (R12-1, R12-2, R12-5, and R12-501)” and add the following after paragraph 02:

Option:
03 A TRAILER LENGTH LIMIT (R12-501) sign (see Figure 6G-1) may be used in advance of highways with length restrictions.

()

2053. Section 6B.G.1208, Work Zone and Higher Fines Signs and Plaques. On pages ~~586~~ 795 and 797, replace the section with the following:

Standard:
01 Where increased fines are imposed for exceeding a reduced speed limit, a FINES HIGHER (R2-6P) plaque (see Figure ~~6F-3~~ 6F-31) shall be installed as a supplement to a Speed Limit (R2-1) sign to identify the beginning point of the higher fines zone.

Support:
02 Law enforcement can assess higher fines if signs indicate the TTC zone, the reduced speed limit, and notice of the enhanced penalty for exceeding the reduced speed limit.

Guidance:
03 If a FINES HIGHER plaque is used with a Speed Limit sign, an END HIGHER FINES ZONE (R2-11) sign (see Figure 6F-3) should be installed at the downstream end of the zone to notify road users of the termination of the increased fines zone.

Option:
04 ~~Individual signs and plaques for TTC zone speed limits and higher fines may be combined into a single sign or may be displayed as an assembly of signs and plaques.~~ A WORK ZONE (G20-5aP) plaque (see Figure 6G-1) may be installed above a Speed Limit sign to emphasize the speed limit in a TTC zone.
05 ~~An END WORK ZONE SPEED LIMIT (R2-12) sign (see Figure 6F-3) may be installed at the downstream end of the reduced speed limit zone.~~ Individual signs and plaques for TTC zone speed limits and higher fines may be combined into a single sign or may be displayed as an assembly of signs and plaques.
06 ~~A WORK ZONE (G20-5aP) plaque (see Figure 6F-3) may be installed above a Speed Limit sign to emphasize the speed limit in a TTC zone.~~

(3-31-22)()

54. Table 6G-1. Temporary Traffic Control Zone Regulatory Sign and Plaque Sizes. On page 796, delete lines 10, 12 and 14 of the table and, after the R12-5 sign, insert a “Trailer Length Limit” sign with “R12-501” in the Sign Designation column, “6G.06” in the Section column, and “36 x 48” in both Conventional Road columns. ()

55. Section 6H.12 EXIT OPEN and EXIT CLOSED Signs (E5-2 and E5-2a). On page 806, replace “see Figure 6H-1” with “see Figure 6I-1” in paragraph 01. ()

56. Section 6H.13 EXIT ONLY Sign (E5-3). On page 806, replace “see Figure 6H-1” with “see Figure 6I-1” in paragraph 01. ()

57. Section 6L.01 Guide Signs – General. On page 811, insert the word “Standard” between paragraphs 06 and 07, and make the text for paragraph 07 bold to indicate a **Standard** statement. ()

58. Section 6L.05 Portable Changeable Message Signs. On pages 830-831: ()

a. In the second sentence of paragraph 01, insert the word “permanent” between the words “for” and “changeable.” ()

b. Insert a new paragraph 12a as follows:

Option:
12a A portable changeable message sign combined with radar detection may be used to convey the speeds of approaching drivers as a message.

()

59. Section 6M.02 Positive Protection and Temporary Traffic Barriers. On page 837, delete the words “Long-term stationary” in Item B of paragraph 03 and capitalize the word “Work.” ()

60. Section 6N.04 Work Affecting Pedestrian and Bicycle Facilities. On page 843, change the first sentence of paragraph 06 to read “*Except for short-term and mobile operations, when a highway shoulder is occupied, a SHOULDER WORK (W21-5) sign should be placed in advance of the activity area.*” ()

61. Section 6N.19 Late Merge. On page 852, replace “R9-4a” with “R4-9a” in paragraph 03. ()

62. Figure 6N-1. Late Merge. On page 853, replace “R9-4a” with “R4-9a.” ()

63. Figure 6P-5. Shoulder Closure on a Freeway (TA-5). On page 869: ()

a. Change the “C” dimension to “A” and the “A” dimension to “C.” ()

b. Replace “W16-2P” with “W16-2aP.” ()

64. Notes for Figure 6P-27-Typical Application 27 Closure at the Side of an Intersection. On page 912, replace item 9 with the following:

9. Turns can be prohibited as required by vehicular traffic conditions, such as where the streets are so narrow that it might be physically impossible to make certain turns, especially for large vehicles.

()

65. Notes for Figure 6P-39—Typical Application 39 Median Crossover on a Freeway. On page 936, delete the last “Option” statement. ()

2166. Table 7B-1. School Area Sign and Plaque Sizes. On page 733971, ~~remove delete references to R1-6a, “In-Street Ped Crossing,” R1-6c, “In-Street Schoolchildren Crossing,” and S4-2PR1-9c; “When Children Are Present.” delete lines 7, 12 and 13 of the “Sign” part of the table; and delete line 8 of the “Plaque” part of the table.~~ (3-31-22)()

2267. Figure 7B-1. Signs in School Areas—Signs and at School Crossings. On page 735973, ~~remove figure S4-2P delete signs S5-3, R2-10, R2-11, and the R2-6aP plaque; on page 974, delete signs R1-5c, R1-6a, R1-6c, and R1-9c.~~ (3-31-22)()

23. ~~Section 7B-11. School Advance Crossing assembly.~~ On page 736, delete “or R1-6a” from the first sentence of paragraph 05. (3-31-22)

24. ~~Figure 7B-6. In-Street Signs in School Areas.~~ On page 741, delete signs R1-6a and R1-6c and remove “and R1-6a” from note 2. (3-31-22)

25. ~~Section 7B-12. School Crossing Assembly.~~ (3-31-22)

a. On page 741, replace paragraph 04 with the following:

~~Option:
04 The In-Street Pedestrian Crossing (R1-6) sign (see Section 2B.12 and Figure 7B-6) or the In-Street Schoolchildren Crossing (R1-6b) sign (see Figure 7B-6) may be used at unsignalized school crossings. If used at a school crossing, a 12 x 4 inch SCHOOL (S4-3P) plaque (See Figure 7B-6) may be mounted above the sign. The STATE LAW legend on the R1-6 series signs may be omitted.~~

(3-31-22)

b. On page 742, replace paragraphs 06 and 07 with the following:

~~06 A 12 inch reduced size in street School (S1-1) sign (See Figure 7B-6) may be used at an unsignalized school crossing instead of the In-Street Pedestrian Crossing (R1-6) or the In-Street Schoolchildren Crossing (R1-6b) sign. A 12 x 6 inch reduced size diagonal downward pointing arrow (W16-7P) plaque may be mounted below the reduced size in street School (S1-1) sign.~~

~~Standard:~~

~~07 If an In-Street Pedestrian Crossing sign, an In-Street Schoolchildren Crossing sign, or a reduced size in street School (S1-1) sign is placed in the roadway, the sign support shall comply with the mounting height and special mounting support requirements for In-Street Pedestrian Crossing (R1-6) signs (see Section 2B.12).~~

(3-31-22)

~~26. Section 7B.15. School Speed Limit Assembly (S4-1P, S4-2P, S4-3P, S4-4P, S4-6P, S5-1).~~ (3-31-22)

~~a. On page 742, remove S4-2P in the title; and~~ (3-31-22)

~~b. On page 743, in paragraph 09, remove the S4-2P.~~ (3-31-22)

68. Figure 7B-2. Example of Signing for a School Zone with a School Speed Limit and a School Crossing. On page 975, delete the two sign assemblies that include the S5-3 sign. ()

69. Section 7B.03 School Crossing Signs. On pages 976 and 978: ()

a. In paragraph 11, delete “(Stop Here For),” delete the reference to the R1-5c sign, and change “Figure 7B-4” to “Figure 7B-1.” ()

b. In paragraphs 12, 13, and 16, delete the references to R1-6a and R1-6c signs. ()

c. In paragraph 14, delete the reference to the R1-9c sign, and replace “R1 series signs” in the last sentence with “R1-9b sign.” ()

d. In paragraph 17, delete the reference to the R1-6a sign. ()

70. Section 7B.05 School Speed Limit Signs and Plaques. ()

a. On page 978, insert a new Option statement between paragraphs 02 and 03 as follows:

Option:
02a At locations where there is no school zone speed limit reduction, a School Speed Limit Assembly (see Figure 7B-1) with a HIGHER FINES (R2-6P) or \$XX FINE (R2-6bP) plaque (see Section 7B.06) may be added following the School (S1-1) sign to remind road users of the posted speed limit and associated increased penalty.

b. On page 978, insert the word “Standard:” between paragraph 02a and paragraph 03. ()

c. On page 978, replace paragraphs 03 and 04 with the following:

03 The downstream end of an authorized school zone shall be identified with an END SCHOOL ZONE (S5-2) sign (see Figures 7B-1, 7B-2, and 7B-4).
Option:
04 A standard Speed Limit (R2-1) sign showing the speed limit for the section of highway that is downstream from the authorized school zone may be mounted on the same post above the End School Zone (S5-2) sign.

d. On page 980, replace paragraph 07 with the following:

07. The static School Speed Limit assembly shall consist of a top plaque (S4-3P) with the legend SCHOOL, a Speed Limit (R2-1) sign, and a bottom plaque (S4-1P, S4-2P, or S4-4P) indicating the specific periods of the day that the special school speed limit is in effect (see Figure 7B-1). When the S4-1P or S4-2P plaque is used, it shall be supplemented by the S4-6P plaque indicating the days of the week that the special school speed limit is in effect.

()

71. Figure 7B-4. Example of Signing for a School Zone with a School Speed Limit and Higher Fines Only for Speeding. On page 979, delete the two (2) sign assemblies that include the S5-3 sign and delete the R2-6aP plaques.

()

72. Section 7B.06 Higher Fines Zone Signs and Plaques in School Areas. On pages 980 and 983:

()

a. Delete paragraphs 02, 04, and 05.

()

b. Replace paragraph 03 with the following:

03. A FINES HIGHER (R2-6P) or \$XX FINE (R2-6bP) plaque shall be posted with either the School Speed Limit (S5-1) sign or School Speed Limit Assembly and shall not be posted beneath the School Zone (S1-1) sign (see Section 7B.05).

()

c. Replace paragraph 06 with the following:

06. Where appropriate, one of the following plaques, listed in order of preference, may be mounted below the sign that identifies the beginning point of the higher fines zone:

A. A WHEN FLASHING (S4-4P) plaque (see Figure 7B-1) if used in conjunction with a yellow flashing beacon, or

B. A TIME OF DAY (S4-1P) plaque (see Figure 7B-1) specifying the times that the higher fines are in effect, if supplemented by an S4-6P plaque indicating the days of the week the higher fines are in effect, or

C. A WHEN CHILDREN ARE PRESENT (S4-2P) plaque (see Figure 7B-1), if supplemented by an S4-6P plaque indicating the days of the week the school speed limit is in effect.

()

d. Delete paragraphs 07-09.

()

73. Figure 7B-5. Example of Signing for a School Zone with Higher Fines for All Traffic Violations. On pages 981 and 982, delete this figure.

()

74. Section 9A.01 General. On page 1047, insert the following two paragraphs between paragraphs 03 and 04:

03a State law allows a person operating a bicycle, human-powered vehicle, or electric-assisted bicycle approaching a STOP sign to slow down and, if required for safety, stop before entering the intersection, and after yielding the right of way to all other traffic, to cautiously make a turn or proceed through the intersection without stopping. (See Section 2B.06)

03b State law allows a person operating a bicycle or human-powered vehicle approaching a steady red signal indication to stop before entering the intersection; and, after yielding the right of way to all other traffic, to enter the intersection to make a turn or proceed straight ahead. (see Section 4A.03)

()

75. Section 9B.01 STOP and YIELD Signs (R1-1, R1-2). On page 1052, change paragraph 01 to read “STOP (R1-1) signs (see Figure 9B-1) shall be installed on bicycle facilities at points where bicyclists are required to slow down and stop, if required for safety, before proceeding.”

()

76. Section 9C.04 Bicycle Warning and Trail Crossing Signs (W11-1 and W11-15). On page 1067, change the word “should” in paragraph 04 to “may.”

()

77. Section 9D.08 Bicycle Route Sign and Auxiliary Plaques. On page 1078, insert the header “Support” between paragraphs 12 and 13.

()

78. Section 9D.13 Two-Stage Bicycle Turn Box Guide Signs (D11-20 Series). On page 1084, insert the header “Support” between paragraphs 08 and 09.

()

005. AVAILABILITY OF THE “MANUAL ON UNIFORM TRAFFIC CONTROL DEVICES FOR STREETS AND HIGHWAYS AND OTHER REFERENCED DOCUMENTS.”

01. Review of Documents. The Manual with an effective date of ~~June 13, 2012~~ January 18, 2024, may be viewed and printed from the Federal Highway Administration website at <http://mutcd.fhwa.dot.gov>. Other referenced documents may be reviewed at the Idaho Transportation Department central office or district offices. Office locations can be found at <https://itd.idaho.gov>. ~~(3-31-22)~~()

006. -- 999. (RESERVED)

IDAPA 39 – IDAHO TRANSPORTATION DEPARTMENT

39.03.60 – RULES GOVERNING OUTDOOR ADVERTISING, ACCIDENT MEMORIALS, AND OTHER OFFICIAL SIGNS

DOCKET NO. 39-0360-2401 (ZBR CHAPTER REWRITE)

NOTICE OF RULEMAKING – PROPOSED RULE

AUTHORITY: In compliance with Section 67-5221(1), Idaho Code, notice is hereby given that this agency has initiated proposed rulemaking procedures. The action is authorized pursuant to Chapters 1, 3, and 19, Title 40, Idaho Code.

PUBLIC HEARING SCHEDULE: Public hearing(s) concerning this rulemaking will be scheduled if requested in writing by twenty-five (25) persons, a political subdivision, or an agency, not later than October 16, 2024.

The hearing site(s) will be accessible to persons with disabilities. Requests for accommodation must be made not later than five (5) days prior to the hearing, to the agency address below.

DESCRIPTIVE SUMMARY: The following is a nontechnical explanation of the substance and purpose of the proposed rulemaking:

This rule establishes provisions concerning the control of outdoor advertising signs, structures or displays along the interstate, primary system of highways, and National Highway System roads of the state of Idaho. This rule was reviewed in accordance with the agency's Zero-Based Regulation review schedule. The proposed edits remove several definitions that are already established through Idaho Code.

FEE SUMMARY: The following is a specific description of the fee or charge imposed or increased: N/A.

FISCAL IMPACT: The following is a specific description, if applicable, of any negative fiscal impact on the state General Fund greater than ten thousand dollars (\$10,000) during the fiscal year resulting from this rulemaking: N/A.

NEGOTIATED RULEMAKING: Pursuant to Section 67-5220(1), Idaho Code, negotiated rulemaking was conducted. The Notice of Intent to Promulgate Rules - Negotiated Rulemaking was published in the July 3, 2024, Idaho Administrative Bulletin, [Vol. 24-7, pages 273-274](#).

INCORPORATION BY REFERENCE: Pursuant to Section 67-5229(2)(a), Idaho Code, the following is a brief synopsis of why the materials cited are being incorporated by reference into this rule: N/A.

ASSISTANCE ON TECHNICAL QUESTIONS, SUBMISSION OF WRITTEN COMMENTS: For assistance on technical questions concerning the proposed rule, contact Brendan Floyd at 208-334-8474.

Anyone may submit written comments regarding this proposed rulemaking. All written comments must be directed to the undersigned and must be delivered on or before October 23, 2024.

DATED this 30th day of August, 2024.

Brendan Floyd
Policy Specialist
Idaho Transportation Department
11331 W. Chinden Blvd.
Boise, ID 83714
208-334-8474
Brendan.floyd@itd.idaho.gov

THE FOLLOWING IS THE PROPOSED TEXT OF DOCKET NO. 39-0360-2401
(ZBR Chapter Rewrite)

39.03.60 – RULES GOVERNING OUTDOOR ADVERTISING,
ACCIDENT MEMORIALS, AND OTHER OFFICIAL SIGNS

000. LEGAL AUTHORITY.

The Idaho Transportation Board adopts this rule under the authority of Section 40-312, Idaho Code. (3-31-22)

001. ~~TITLE AND SCOPE~~ PURPOSE.

~~01. Title. This rule is titled IDAPA 39.03.60 “Rules Governing Outdoor Advertising, Accident Memorials, and Other Official Signs,” IDAPA 39, TITLE 03, Chapter 60. (3-31-22)~~

~~02. Scope. This rule contains guidelines for the control of outdoor advertising signs, structures or displays along the interstate, primary system of highways, and National Highway System roads of the state of Idaho pursuant to Chapters 1, 3, and 19, Title 40, Idaho Code. (3-31-22)()~~

002. -- 009. (RESERVED)

010. DEFINITIONS.

~~The Idaho Transportation Department adopts the definitions set forth in Sections 40-101 through 40-127, Idaho Code. In addition, as used in this chapter: (3-31-22)~~

~~01. Advertising Structure(s) or Sign(s), or Advertising Display(s). Any outdoor structure, display, light device, figure, painting, drawing, message, plaque, poster, billboard, or other thing which is designed, intended, or used to advertise or inform. These do not include: (3-31-22)()~~

~~a. Official notices issued by any court or public body or officer. (3-31-22)~~

~~b. Notices posted by any public officer in performance of a public duty or by any person giving legal notice. (3-31-22)~~

~~c. Directional, warning, or informational structures required by or authorized by law, informational or directional signs regarding telephone service, emergency telephone signs, buried or underground cable markers and above cable closures. (3-31-22)~~

~~d. An official or public structure erected near a city or county, and within its territorial or zoning jurisdiction, which contains the name of such city or county, provided the same is maintained wholly at public expense. (3-31-22)~~

~~02. Bypassed Community Signs. A form of community official sign erected when a city has been bypassed, but remains within five (5) miles of an interstate highway or primary freeway. Such communities have the right to erect and maintain, at city expense, a billboard displaying the name of the city at a location not to exceed one (1) mile from an interchange primarily serving that city. (3-31-22)~~

~~03. Commercial or Industrial Activities. Those activities generally recognized as commercial or industrial by zoning authorities in this State, except that none of the following activities are considered commercial or industrial: (3-31-22)~~

~~a. Agricultural, forestry, grazing, farming, and related activities, including but not limited to, wayside fresh produce stands. (3-31-22)~~

- b. Transient or temporary activities. (3-31-22)
- c. Activities not visible from the main traveled way. (3-31-22)
- d. Activities conducted in a building principally used as a residence. (3-31-22)
- e. Railroad tracks and minor sidings. (3-31-22)
- f. Outdoor advertising displays. (3-31-22)

04. Commercial or Industrial Zones. The provisions of Section 40-1911, Idaho Code, do not apply to those segments of the interstate and primary system of highways which traverse and abut on commercial, business, or industrial zones within the boundaries of incorporated municipalities, wherein the use of real property adjacent to and abutting on the interstate and primary system of highways is subject to municipal or county regulation or control, or which traverse and abut on other areas where the land use is clearly established by State law or county zoning regulation, as industrial, business, or commercial, or which are located within areas adjacent to the interstate and primary system of highways which are in unzoned commercial or industrial areas as determined by the Department from actual land uses; provided, however, that the Department will determine the size, lighting, and spacing of signs in such zoned and unzoned industrial, business, or commercial areas. For the purpose of this rule, areas abutting interstate and primary highways of this State which are zoned commercial or industrial by counties and municipalities are to be valid as commercial or industrial zones only as to the portions actually used for commerce or industrial purposes and the land along the highway in urban areas for a distance of six hundred (600) feet immediately abutting to the area of the use, and does not include areas so zoned in anticipation of such uses at some uncertain future date nor does it include areas so zoned for the primary purpose of allowing advertising structures. (3-31-22)

05. Community Official Signs. Signs approved by a city, erected within its territorial or zoning jurisdiction and maintained wholly at city expense. These signs will display only the name of the city and driver directional information. Specific advertising is not allowed. (3-31-22)

06. Customary Maintenance. Repainting the structure, trim, or sign face, changing poster paper, replacing existing electrical components after failure and replacing damaged structural parts. It does not include the installation of a new sign face nor the initial installation of lighting. Substantial replacement begins when repair and other costs exceed fifty percent (50%) of the sign's reproduction cost. (3-31-22)

~~**07. Department.** The Idaho Transportation Department, acting through the Idaho Transportation Board. (3-31-22)~~

~~**087. Directional Signs.** Signs containing directional information about public places owned or operated by federal, state, or local governments or their agencies; publicly or privately owned natural phenomena, historic, cultural, scientific, educational and religious sites; and areas of natural scenic beauty or naturally suited for outdoor recreation, deemed to be in the interest of the traveling public. (3-31-22)~~

~~**098. Erect.** To construct, build, raise, assemble, place, affix, create, paint, draw, or in any other way bring into being or establish, but does not include any of the foregoing activities when performed incident to the change of an advertising message or customary maintenance of a sign. (3-31-22)~~

~~**10. Federal or State Law.** A federal or state constitutional provision or statute, or an ordinance, rule, or regulation enacted or adopted by this state or a federal agency or a political subdivision of this state pursuant to a federal or state constitution or statutes. (3-31-22)~~

~~**109. Freeway.** A divided highway with four (4) or more lanes for through traffic and full control of access. (3-31-22)~~

~~**120. Grandfather Sign.** One which was lawfully in existence in a zoned or unzoned commercial or industrial area on the effective date of the State law and which may remain even though it may not comply with the size, lighting, or spacing criteria within this rule. This clause only allows an individual sign at its particular location for the duration of its normal life subject to customary maintenance. (3-31-22)~~

- ~~131.~~ **Illegal Sign.** One which was erected and/or maintained in violation of State law. (3-31-22)
- ~~14.~~ **Interstate System or Interstate Highway.** Any portion of the national system of interstate and defense highways located within the state, as officially designated, or as may hereinafter be so designated, by the Idaho Transportation Board, and approved by the Secretary of Transportation, pursuant to the provisions of Title 23, U.S. Code, "Highways." (3-31-22)
- ~~15.~~ **Maintain or Place.** To allow to exist, subject to the provision of Chapter 19, Title 40, Idaho Code. (3-31-22)
- ~~16.~~ **Maintenance.** To preserve from failure or decline, or repair, refurbish, repaint or otherwise keep an existing highway or structure in a suitable state for use. (3-31-22)
- ~~172.~~ **Main Traveled Way.** The portion of a roadway for the movement of vehicles, exclusive of shoulders. (3-31-22)
- ~~183.~~ **Multiple Message Sign (MMS).** A sign, display, or device that changes the message or image on the sign electronically by movement or rotation of panels or slats, or electronic billboards that have a programmable display of variable text or symbolic imagery. (3-31-22)
- ~~194.~~ **Nonconforming Sign.** One which was lawfully erected, but does not comply with the provisions of State law or State regulation passed at a later date or which later fails to comply with State law or State regulation due to changed conditions. Illegally erected and/or maintained signs are not nonconforming signs. All signs located within an unzoned area are nonconforming if the commercial or industrial activity used in defining the area ceases for a continuous period of six (6) months. (3-31-22)
- ~~2015.~~ **Official Signs and Notices.** Signs and notices erected and maintained by public officers or public agencies within their territorial or zoning jurisdiction and pursuant to and in accordance with direction or authorization contained in federal, state, or local law for the purposes of carrying out an official duty or responsibility. Historical markers authorized by state law and erected by state or local government agencies or nonprofit historical societies may be considered official signs. (3-31-22)
- ~~216.~~ **Parkland.** Any publicly owned land which is designated or used as a public park, recreation area, wildlife or water fowl refuge or historical site. (3-31-22)
- ~~2217.~~ **Permit.** A written approval by the department covering location, size, lighting, spacing, number and message content requirements of permissible directional signs. (3-31-22)
- ~~23.~~ **Permit Application.** The form or format of information and data supplied by an individual, agency, or organization to obtain approval for erection and maintenance of a directional sign. (3-31-22)
- ~~24.~~ **Primary System or Primary Highway.** Any portion of the highways of the state, as officially designated, or as may hereafter be so designated, by the Idaho Transportation Board, and approved by the Secretary of Transportation, pursuant to the provisions of Title 23, U.S. Code, "Highways." (3-31-22)
- ~~2518.~~ **Public Service Signs.** Signs located on school bus or other bus stop bench or shelter, which: (3-31-22)
- a. Identify the donor, sponsor, or contributor of said shelters; (3-31-22)
 - b. Contain public service messages, which will ~~not~~ occupy not less than fifty percent (50%) of the area of the sign; (3-31-22)()
 - c. Contain no other message; (3-31-22)
 - d. Are located on school bus or other bench or shelter authorized or approved by city, county, or state

law, regulation, or ordinance, and at places approved by the city, county, or state agency controlling the highway involved; and (3-31-22)

e. May not exceed thirty-two (32) square feet in area. Not more than one (1) sign on each bench or shelter ~~shall will~~ face in any one (1) direction. (3-31-22)()

2619. Public Utility Signs. Warning signs, informational signs, notices, or markers which are customarily erected and maintained by publicly or privately owned public utilities, as essential to their operations. (3-31-22)

270. Regionally Known. The attraction or activity must be known statewide and in one (1) or more adjoining states. (3-31-22)

281. Rest Area. Any area of particular scenic beauty or historical significance as determined by the federal, state, or local officials having jurisdiction thereof, and includes interests in land which have been acquired for the restoration, preservation, and enhancement of scenic beauty. (3-31-22)

292. Service Club and Religious Notices. Signs and notices, whose erection is authorized by law, relating to meeting of nonprofit service clubs or charitable associations, or religious services, which do not exceed eight (8) square feet in area. (3-31-22)

3023. Sign. An outdoor sign, light, display, device, figure, painting, drawing, message, placard, poster, billboard, or other thing which is designed, intended, or used to advertise or inform, any part of the advertising or informative contents of which is visible from any place on the main traveled way of the interstate or primary highway. (3-31-22)

3124. Sign Face. The overall dimensions or area of that portion or side of an individual sign structure that is designed, intended, and capable of displaying messages. It includes border and trim, but excludes the base or apron, supports and other structural members. (3-31-22)

3225. Sign Structure. A construction including the sign face, base or apron, and other structural members. (3-31-22)

~~33. State. State of Idaho.~~ (3-31-22)

3426. Territorial or Zoning Jurisdiction. The geographical area located outside of any city or county limits for a distance of three (3) miles. (3-31-22)

3527. Transient or Temporary Activity. An activity is transient or temporary for the purposes of Chapter 19, Title 40, Idaho Code when: (3-31-22)

a. The activity lacks any business or privilege license required by the city, county or state. (3-31-22)

b. The activity on the property has not been conducted for at least six (6) months at the time of application for a sign permit. (3-31-22)

c. The activity lacks utilities (water, power, telephone, etc.) and which are normally utilized by similar commercial activities. (3-31-22)

d. The activity is not carried on in a permanent building designed, built or modified for its current commercial or industrial use, located within six hundred sixty (660) feet of the nearest edge of the right-of-way. (3-31-22)

e. The property upon which the activity is conducted lacks direct or indirect vehicular access or does not generate vehicular traffic. (3-31-22)

f. The activity does not have employees on-site during normal business hours which is considered

normal, usual, and customary. (3-31-22)

g. The activity lacks a frequency of operations which are considered usual, normal and customary for that type of commercial or industrial operation and the activity is visible and recognizable as a commercial or industrial activity. (3-31-22)

~~**36. Unzoned Commercial or Industrial Area.** Any area not zoned by State or local law, regulation or ordinance which is occupied by one (1) or more industrial or commercial activities, other than outdoor advertising signs, and the land along the highway for a distance of six hundred (600) feet immediately abutting to the area of the activities. All measurements need to be from the outer edge of the regularly used buildings, parking lots, storage, or processing areas of the activities, and shall be along or parallel to the edge of pavement of the highway. (3-31-22)~~

~~**3728. Urban Areas.** Any geographical area within the city limits of any incorporated city having a population of five thousand (5,000) or more inhabitants. Population numbers referred to in this Subsection shall will be determined by the latest United States census. (3-31-22)()~~

~~**38. Visible.** Capable of being seen (whether or not legible) without visual aid by a person of normal visual acuity. (3-31-22)~~

011. -- 099. (RESERVED)

100. GENERAL.

01. Visible Informative Content. This rule applies only to advertising displays whose informative content is visible from the main traveled way of interstate or primary highways. (3-31-22)

02. Responsibilities. Both the owner of a sign and the landowner upon whose property the sign is located will be held responsible for violations of this rule. (3-31-22)

03. Nonconforming Signs. Signs which stand without advertising copy, obsolete advertising matter, or continued need for repairs beyond customary maintenance constitute discontinuance and abandonment after a period of six (6) months and will be subject to removal. (3-31-22)

04. Signs Visible from the Main Travel-Way. Signs beyond six hundred and sixty (660) feet from the right-of-way will be considered to have been erected with the purpose of their message being read from the main traveled way when: (3-31-22)

a. The sign angle and size is such that the message content is readily visible from the main traveled way; or (3-31-22)

b. The exposure time is long enough at the maximum speed limit for the sign message to be readable and comprehensible. (3-31-22)

05. Permit or License Revocation. The erection or maintenance of signs from the highway right-of-way; or the destruction of trees or shrubs within the highway right-of-way will be cause for permit or license revocation. (3-31-22)

06. Multiple Sign Faces. Criteria which permit multiple sign faces to be considered as one (1) sign structure for spacing purposes are limited to signs which are physically contiguous, or connected by the same structure or cross-bracing. (3-31-22)

07. Edge of Right-of-Way. Distance from the edge of the right-of-way is measured horizontally along a line normal or perpendicular to the centerline of the highway. (3-31-22)

08. Control Requirement. Where a sign is erected with the purpose of its message being read from two (2) or more highways, one (1) or more of which is a controlled highway, the more stringent of applicable control requirements will apply. (3-31-22)

101. -- 109. (RESERVED)

110. EXEMPTIONS AUTHORIZED BY SECTION 40-1904, IDAHO CODE.

01. Signs Erected by Public Officers or Agencies. Directional and other official signs and notices erected by public officers or agencies will be issued permits at no cost to the owners, as described more fully elsewhere in this rule. (3-31-22)

02. Advertising Sale or Lease of Property. Signs advertising the sale or lease of property upon which they are located. These signs ~~shall~~ will not advertise any products, services, or anything unrelated to the selling or leasing of the property. (3-31-22)()

03. On-Premise Signs. Signs (on-premise) advertising activities conducted on the property upon which they are located are allowed, subject to the following: Not more than one (1) such sign, visible to traffic proceeding in any one (1) direction and advertising activities being conducted upon the real property where the sign is located may be permitted more than fifty (50) feet from the advertised activity. The criteria for determining the limits of the area of the advertised activity from which the fifty (50) feet measurement can be taken are as follows: (3-31-22)

a. When the advertised activity is a business, commercial, or industrial land use, the distance ~~shall~~ will be measured from the regularly used buildings, parking lots, storage, or processing areas, or other structures which are essential and customary to the conduct of the business and within its limits of the real property. It is not be measured from driveways, fences, or similar facilities. (3-31-22)()

b. When the advertised activity is a noncommercial or nonindustrial land use such as a residence, farm, or orchard, the distance is measured from the major structures on the property. (3-31-22)

c. In no event will a sign site be considered part of the premises on which the advertised activity is conducted if it is located upon a narrow strip of land which is nonbuildable land, such as, but not limited to, swampland, marshland, or other wetland, or which is a common or private roadway, or held by easement or other lesser interest than the premises where the advertised activity is located. (3-31-22)

111. -- 119. (RESERVED)

120. DISPLAYS LOCATED WITHIN ZONED OR UNZONED INDUSTRIAL, BUSINESS OR COMMERCIAL AREAS.

01. Size of Signs. Within zoned and unzoned commercial, business, or industrial areas, and pursuant to the directive of Section 40-312, Idaho Code, the face of an advertising display ~~shall~~ will not exceed the following size limits: (3-31-22)()

a. Maximum area - one thousand (1000) square feet; (3-31-22)

b. Maximum height - thirty (30) feet; (3-31-22)

c. Maximum length - fifty (50) feet. (3-31-22)

02. Dimensions. The area of a sign face will include all of the border, trim, cutouts, and extensions. (3-31-22)

03. Spacing of Advertising Displays. Within zoned and unzoned commercial, business, or industrial areas, as defined in Section 010 herein and pursuant to directive of Section 40-1912, Idaho Code, the following spacing regulations apply: (3-31-22)

a. Advertising displays on interstate and primary highways may not be located in such a manner as to obscure or otherwise interfere with the effectiveness of an official traffic sign, signal, or device, or to obstruct or

interfere with the driver's view of approaching, merging, or intersecting traffic. (3-31-22)

b. Advertising displays on interstate and primary highways may not be located within five hundred (500) feet of any of the following which are adjacent to the highway: public parks; public forests; public playgrounds; scenic areas designated as such by the Department or other State agencies having and exercising such authority. (3-31-22)

c. In a case where the highway passes beneath a railroad overpass or beneath a highway grade separation structure where no traffic connection between the crossing highways is provided, no advertising display may be located on the road passing beneath the structure within a distance of five hundred (500) feet from the nearest edge of the overhead route. (3-31-22)

d. Measurement between signs or from a sign to another feature ~~shall~~ will be made horizontally along the pavement edge nearest the signs, between points directly opposite the signs or other features. The point of the sign nearest to the highway is used to determine the measurement point. (3-31-22)()

e. Two (2) sign faces will be permitted at a single location, arranged back to back, or in a V-type configuration, but ~~shall~~ will only have one (1) sign face visible to one (1) direction of travel and will be considered as one (1) sign for spacing regulation. (3-31-22)()

f. Signs erected by public agencies or officers and on-premise signs, as defined in Section 010 of this rule, ~~shall~~ will not be counted nor ~~shall~~ will measurements be made from them for determining compliance with spacing requirements. (3-31-22)()

g. Spacing on interstate highways between advertising displays along each side of the highway ~~shall~~ will be a minimum of five hundred (500) feet. The spacing between multiple message signs ~~shall~~ will be a minimum of five thousand (5,000) feet. (3-31-22)()

h. No advertising display on interstate highways ~~shall~~ will be erected or maintained within one thousand (1000) feet of an interchange or rest area with the exception of permitted, existing displays which ~~shall~~ will have grandfather rights. The minimum spacing between displays as set forth herein for interstate highways ~~shall~~ will govern the actual location of any sign display permitted and existing within this zone. No advertising display subject to this regulation ~~shall~~ will be permitted along any interstate highways within the actual "interchange area," defined as commencing or ending at the beginning or ending of pavement widening at the exit or entrance to the main traveled way of the interstate freeway. (3-31-22)()

i. The spacing of signs on primary highways between advertising displays along each side of the highway ~~must~~ will be a minimum of one hundred (100) feet in urban areas and a minimum of two hundred and fifty (250) feet outside of urban areas. The spacing between multiple message signs ~~shall~~ will be a minimum of one thousand (1,000) feet in urban areas and a minimum of five thousand (5,000) feet outside urban areas. (3-31-22)()

j. Where intersections are more than five hundred (500) feet apart, no off-premise advertising display will be permitted within one hundred (100) feet from the right-of-way line of the intersecting road unless buildings or structures control cross vision; then advertising displays may be permitted up to and on top of the intervening structures. (3-31-22)

k. When intersections are five hundred (500) feet or less apart, off-premise advertising displays will be permitted a minimum of fifty (50) feet from the right-of-way line of the intersecting road; however, all advertising displays between fifty (50) feet and one hundred (100) feet from the right-of-way line of the intersecting road ~~must~~ will have the lower extremities of the advertising display (excluding posts) not less than fourteen (14) feet above the traveled way of the roads affected by the intersection for visibility under the signs by road users. Advertising displays may be permitted within one hundred (100) feet of the intersecting road's right-of-way when buildings or structures control cross vision; but such displays ~~must~~ will not be located so as to cause greater restriction to vision than the existing buildings or structures. (3-31-22)()

l. Alleys, undeveloped rights-of-way, private roads and driveways ~~shall~~ will not be regarded as

intersecting streets, roads or highways. (3-31-22)()

m. Advertising structures may not be located within five hundred (500) feet of the point of pavement widening at the entrance or exit to a rest area, weight checking station, port of entry or other State-operated facility for the use of motorists. (3-31-22)

04. Lighting. (3-31-22)

a. No sign will be allowed if it is so illuminated that it interferes with the effectiveness of, or obscures an official traffic sign, device, or signal. (3-31-22)

b. Section 40-1910, Idaho Code, prohibits advertising structures which are visible from any interstate or primary highway and display any red or blinking intermittent light likely to be mistaken for a warning or danger signal. (3-31-22)

c. Section 40-1910, Idaho Code, prohibits advertising displays which include any illumination of such brilliance and so positioned as to blind or dazzle the vision of travelers on adjacent interstate and primary highways. (3-31-22)

05. Variable or Multiple Message Signs. (3-31-22)

a. Multiple message signs ~~shall will~~ not include any illumination or image which moves continuously, appears to be in motion or has any moving or animated parts or video displays or broadcasts. No multiple message sign may include any illumination which is flashing or moving, except those giving public service information such as date, time, temperature, weather, or other similar information. (3-31-22)()

b. If illuminated with beams or rays of such intensity or brilliance that it would cause glare or impair the vision of the driver or interfere with the operation of a motor vehicle, effective shielding ~~must will~~ be in place so as to prevent beams or rays of light from being directed at any portion of the traveled way. (3-31-22)()

c. If illuminated, illumination ~~must will~~ not obscure or interfere with the effectiveness of official traffic sign, device, or signal. (3-31-22)()

d. Multiple message signs ~~must will~~ not emit or utilize any sound capable of being detected. (3-31-22)()

e. The message or image on a multiple message sign must remain static for a minimum of eight (8) seconds. (3-31-22)

f. An automated change of message or image on a multiple message sign must be accomplished within two (2) seconds or less and contain a default design that will freeze the sign face in one (1) position should a malfunction occur. (3-31-22)

g. If a multiple message sign is in violation of any of the conditions listed in Subsection 300.05.a. through 300.05.g., the permit will be revoked. (3-31-22)

121. -- 129. (RESERVED)

130. LICENSES.

~~Pursuant to Sections 40-1905, 40-1906 and 40-1907, Idaho Code, no person will be allowed to engage in the business of outdoor advertising without first having secured an outdoor advertising license and paid the required license fee. Licenses ~~must will~~ be renewed annually; the Department cannot renew licenses for a period longer than one (1) year at a time. License application forms may be secured at the Idaho Transportation Department District Offices, as listed in Section 005 of this rule.~~ (3-31-22)()

131. -- 139. (RESERVED)

140. OUTDOOR ADVERTISING PERMITS.

No person may place any advertising display within the areas affected by the provisions of Section 40-1907, Idaho Code, without first having secured a written permit from the Department. (3-31-22)

01. Application Forms. Permit application forms may be secured at the Idaho Transportation Department District Offices. (3-31-22)

02. Expiration of Annual Permits. Annual permits will expire December 31 each year, but a multi-year permit may be issued as a convenience to the outdoor advertiser. An original annual permit fee of ten dollars (\$10) ~~shall~~ will accompany each original permit application. An annual renewal fee of three dollars (\$3) will be assessed for each permit, and the Department will mail a bill to each sign owner annually. Payment for the renewal of a permit must be received at least thirty (30) days prior to the expiration date. Permit fees will not be prorated for a fraction of a year. (3-31-22)()

03. Modified Advertising Structures. Whenever an advertising structure is relocated or undergoes substantial replacement beyond customary maintenance, the modified structure will be considered to be a new sign. ~~Therefore, p~~ Pursuant to Section 40-1906, Idaho Code, an application for a new display ~~must~~ will be submitted before such reconstruction is begun. A permit fee of ten dollars (\$10) must accompany the application. Conversion of a sign face to a multiple message sign face will be considered substantial replacement beyond customary maintenance and considered a new sign. (3-31-22)()

a. Nonconforming signs which are allowed to be maintained until the State requires their removal cannot be modified so as to increase the reproduction cost. They must remain substantially the same as they were on the effective date of the state law and any subsequent amendments. (3-31-22)

b. The categories of nonconforming signs which may be maintained until they are removed, and nonconforming signs which have been “grandfathered” in commercial and industrial areas cannot include new signs erected in their place or any changes to the existing sign which would be beyond customary maintenance. (3-31-22)

04. Space Requirement Violations. In the event that two (2) or more lawfully erected signs along the interstate and primary highways are in violation of the spacing requirements and the regulations promulgated by the Department, the Department ~~shall~~ will accord the interested parties a full opportunity to be heard and ~~shall~~ will thereafter make a finding as to the date of erection of each of the signs and award the permit or permits to the applicants whose signs were first erected. (3-31-22)()

05. Application. All applications received during the Department’s normal office hours during the same mail pickup will be construed to have been received simultaneously. In the case of a tie between applicants and upon notification thereof by the Department, it ~~shall~~ will determine by lot which will receive the permit. (3-31-22)()

06. Permit Denial. No permit will be issued for a new sign having two (2) or more faces in any one (1) direction. (3-31-22)

07. Physically Connected Signs. Two (2) sign structures which are physically connected will be considered as a single sign for permit purposes. (3-31-22)

08. Standard Permit Application. Owners of displays defined under Sections 40-102(4) and 40-1904, Idaho Code, will be requested to submit a standard permit application for each such display. Identification tags will be issued for such displays at no cost to the owners. No applications will be requested for minor signs, or emergency telephone signs, nor will tags be issued for them. (3-31-22)

09. Lost or Destroyed Identification Tags. Identification tags, except those issued under Subsection 401.08, which are lost or destroyed either before or after being attached to signs will be replaced only upon payment of a three dollar (\$3) fee. Tags issued under Subsection 401.08 will be replaced at no cost if lost or destroyed. (3-31-22)

10. Invalid Permit. A permit will only be issued for a sign that is lawfully erected within one hundred

and eighty (180) days of the permit issuance date. The identification tag is to be affixed only to the sign for which it was issued and ~~must will~~ be so affixed within one hundred and eighty (180) days after being received; otherwise, the permit automatically becomes invalid. (3-31-22)()

11. Cancellation of Permit. If the sign for which a permit has been issued is removed, destroyed, or for any reason becomes unusable prior to the expiration date of permit, the permit may be canceled. (3-31-22)

12. Advertising Illegal Activities. Signs advertising activities illegal under Federal, State, or local law are not eligible for permits. (3-31-22)

13. Revoked Permits. When the Department determines a false or misleading statement has been made in the application for a license or permit, said license or permit ~~shall will~~ be revoked. (3-31-22)()

14. Appeal Process. In the event a permit is denied or revoked, the applicant may obtain instructions for the appeal process at any of the Idaho Transportation Department District Office ~~locations listed in Section 005s.~~ (3-31-22)()

141. -- 149. (RESERVED)

150. BONDS OF OUT-OF-STATE PERMITTEES AND LICENSEES.

As authorized by Section 40-1908, Idaho Code, a bond in the penal sum of one thousand dollars (\$1000) ~~shall will~~ be paid by all non-resident or foreign corporation permittees and licensees. (3-31-22)()

151. -- 199. (RESERVED)

200. GENERAL: TRAFFIC ACCIDENT MEMORIALS.

In accordance with Section 49-1316, Idaho Code, relatives or friends of a person killed in a traffic accident upon a state highway may apply for a permit to erect a memorial in memory of the decedent. Only one (1) memorial may be placed per fatal accident. Memorials placed before January 1, 2003 may be retained if they meet all of the requirements of Section 202 and Subsections 215.01 through 215.03, of this rule. (3-31-22)

201. TRAFFIC ACCIDENT MEMORIAL PERMIT.

After January 1, 2003, relatives or friends of a person killed in a traffic accident upon a state highway may obtain an approved encroachment permit from the Department prior to installing, maintaining or removing a memorial within the state highway right-of-way. As a condition of permit approval, the individual(s) wishing to install a memorial needs to provide the Department with the following: (3-31-22)

01. Written Approval from the Next of Kin. Written approval from the decedent's next of kin, who are related by blood, marriage or adoption; and (3-31-22)

02. Written Approval from the Property Owner. Written approval from all property owners whose property is within a five hundred foot (500') radius of the proposed memorial location. (3-31-22)

202. PHYSICAL REQUIREMENTS.

The maximum dimensions of a memorial ~~shall will~~ be thirty-six (36) inches high, sixteen (16) inches wide and ~~shall will~~ weigh no more than seven (7) pounds. The height requirement is measured from the ground level to the highest point on the memorial, the width ~~shall will~~ be measured horizontally at the memorial's widest point and the weight is based on the portion above the ground. (3-31-22)()

01. Shape and Color. Memorials ~~shall will~~ not be shaped or colored to portray, resemble or conflict with any traffic control device. The memorial ~~shall will~~ not be reflectorized. (3-31-22)()

02. Memorial Site. Planting or landscaping at a memorial is not allowed. (3-31-22)

203. -- 214. (RESERVED)

215. LOCATION.

Memorials ~~must~~ will be erected as near as practical to the milepost location where the accident occurred. The person installing the memorial is responsible for contacting a utility locating service to identify the location of any utilities in the area prior to placement of the memorial. See call-before-you-dig requirements in Sections 55-2201 through 55-2210 of Idaho Code. The applicant is required to meet on site with the Department highway maintenance supervisor assigned to the area where a memorial is to be erected to review the proposed installation. The Department highway maintenance supervisor will be responsible for final approval of the memorial location. (3-31-22)()

01. Shoulder. Memorials ~~shall~~ will be placed as far as practical from the edge of roadway, but must be placed a minimum of twenty (20) feet from the roadway shoulder where highway right-of-way width permits. (3-31-22)()

02. Medians. Placement of an accident memorial in the median of any interstate or non-interstate highway is ~~prohibited~~ not allowed. (3-31-22)()

03. Incorporated Cities. Memorials are not allowed within the boundaries of incorporated cities. (3-31-22)

216. -- 219. (RESERVED)

220. SAFETY.

01. Parking. Those participating in the installation, maintenance, or removal of the memorial ~~shall~~ will park their vehicle(s) as far as practical from the travel lanes and in an area where there is adequate sight distance on the highway in both directions. (3-31-22)()

02. Participants and Motorists. Those participating in the installation, maintenance, or removal of a memorial ~~must~~ will wear proper safety attire and obey all safety procedures approved by the Department at the time of permit issuance. A high degree of safety must be maintained for the traveling public and the participants during the installation, maintenance, or removal of a memorial. (3-31-22)()

221. -- 239. (RESERVED)

240. MAINTENANCE.

The Department is not responsible for maintenance, vandalism, damage, or theft of a memorial. The permittee is responsible for maintenance of the memorial. All memorials need to be maintained in good condition at all times and in a manner that complies with this rule. (3-31-22)

241. COMPLIANCE.

01. Improper Installation. Memorials not installed in compliance with this rule are subject to removal by the Department. (3-31-22)

02. Maintenance. Memorials not maintained in good condition are subject to removal by the Department. (3-31-22)

03. Traffic Hazard. Memorials that have been installed or maintained in such a manner that either the memorial or the participants create a traffic hazard are subject to removal by the Department. (3-31-22)

242. -- 299. (RESERVED)

300. GENERAL: STANDARDS FOR COMMUNITY OFFICIAL SIGNS.

01. Direction of Sign. Only one (1) community sign may face the same direction of travel along a single route approaching the community. (3-31-22)

02. Location of Sign. A community sign may not be located within two thousand (2,000) feet of an interchange, along the interstate system or other freeways (measured along the interstate or freeway from the nearest

point of the beginning or ending of pavement widening at the exit from or entrance to the main traveled way) or located within one thousand (1,000) feet of an intersection of a primary route with another designated federal-aid route. Community signs may not be located within two thousand (2,000) feet of a rest area, park land or scenic area. (3-31-22)

03. Size of Sign. Community signs ~~shall~~ **will** not exceed the following limits: (3-31-22)()

a. Maximum area -- Three hundred (300) square feet. (3-31-22)

b. Maximum height -- Thirty (30) feet. (3-31-22)

c. Maximum length -- Thirty (30) feet. (3-31-22)

301. STANDARDS FOR DIRECTIONAL SIGNS.

01. Prohibited Directional Signs. ~~The following directional signs are prohibited:~~ (3-31-22)()

a. Signs advertising activities that are illegal under federal or state laws or regulations in effect at the location of those signs or at the location of those activities. (3-31-22)

b. Signs located in such a manner as to obscure or otherwise interfere with the effectiveness of an official traffic sign, signal, or device, or obstruct or interfere with the driver's view of approaching, merging, or intersecting traffic. (3-31-22)

c. Signs which are erected or maintained upon trees or painted or drawn upon rocks or other natural features. (3-31-22)

d. Signs which are structurally unsafe or in disrepair. (3-31-22)

e. Signs which move or have any animated or moving parts. (3-31-22)

f. Signs located in rest areas, parklands, or scenic areas. (3-31-22)

g. Signs that advertise or call attention to an activity or attraction no longer in existence and/or abandoned or obsolete signs. (3-31-22)

h. Signs not maintained in a neat, clean, and attractive condition or in good repair. (3-31-22)

i. Signs not designed to withstand a wind pressure of thirty (30) pounds per square foot of exposed surface. (3-31-22)

j. A sign installation that has not been issued an annual permit. (3-31-22)

02. Size of Directional Signs. (3-31-22)

a. Signs ~~shall~~ **will** not exceed the following limits: Maximum area, one hundred and fifty (150) square feet; maximum height twenty (20) feet; maximum length, twenty (20) feet. (3-31-22)()

b. All dimensions include border and trim, but exclude supports. (3-31-22)

03. Spacing of Directional Signs. (3-31-22)

a. Each location of a sign ~~must~~ **will** be approved by the department and the property owner on whose property the sign is installed. (3-31-22)()

b. A sign may not be located within two thousand (2,000) feet of an interchange, along the interstate system or other freeways (measured along the interstate or freeway from the nearest point of the beginning or ending

of pavement widening at the exit from or entrance to the main traveled way), or located within one thousand (1,000) feet of an intersection of a primary route with another designated federal-aid route. (3-31-22)

- c. A sign may not be located within two thousand (2,000) feet of a rest area, park land, or scenic area. (3-31-22)
 - d. A sign ~~shall~~ will not be located within one (1) mile of any other directional sign facing the same direction of travel. (3-31-22)()
 - e. Not more than three (3) signs pertaining to the same activity and facing the same direction of travel may be erected along a single route approaching the activity. (3-31-22)
 - f. Signs located adjacent to the interstate system ~~shall~~ will be within seventy-five (75) air miles of the activity. (3-31-22)()
 - g. Signs located adjacent to the primary system ~~shall~~ will be within fifty (50) air miles of the activity. (3-31-22)()
- 04. Message Content.** The message on directional signs ~~shall~~ will be limited to the identification of the attraction or activity and directional information useful to the traveler in locating the attraction, such as mileage, route numbers, or exit numbers. Descriptive words or phrases and pictorial or photographic representations of the activity or its environs are ~~prohibited~~ not allowed. (3-31-22)()

302. -- 319. (RESERVED)

320. LIGHTING, SIGNS MAY BE ILLUMINATED, SUBJECT TO THE FOLLOWING.

- 01. Flashing or Moving Lights.** Signs which contain, include, or are illuminated by any flashing, intermittent, or moving light or lights are ~~prohibited~~ not allowed. (3-31-22)()
- 02. Lights Which Impair Driver Vision.** Signs which are not effectively shielded so as to prevent beams or rays of light from being directed toward any portion of the traveled way of a highway or which are of such intensity or brilliance as to cause glare or to impair the vision of the driver of any motor vehicle, or which otherwise interfere with any driver's operation of a motor vehicle are ~~prohibited~~ not allowed. (3-31-22)()
- 03. Interference With Traffic Sign, Device, or Signal.** A sign may not be so illuminated as to interfere with the effectiveness of, or obscure an official traffic sign, device, or signal. (3-31-22)

321. -- 339. (RESERVED)

340. ADMINISTRATION.

- 01. Selection Methods and Criteria.** (3-31-22)
 - a. Application for permits to erect and maintain directional and official signs under this regulation ~~shall~~ will be filed with the Idaho Transportation Department, Division of Highways. (3-31-22)()
 - b. The approval of applications of directional signs is to be based on the following criteria: Nationally or regionally known activity of outstanding interest to the traveling public; location of activity relative to highway and proposed signing plan; dominant attraction must be for edification and enjoyment of motorist, not tourist-oriented business or for generation of activity income; and Attraction or Activity ~~shall~~ will have drinking water and toilet facilities meeting the Idaho Department of Health and Welfare standards. (3-31-22)()
 - c. The applicant of directional signs will furnish to the department the following data: Proposed sign plans including sign details, color, construction, shape, legend, lighting and location; letter of property owner approval of directional sign installation; department of Health and Welfare certification that water and toilet facilities meet Idaho standards; and documentation and explanation by applicant if it is a regionally known attraction or

activity of outstanding interest to the traveling public. (3-31-22)

d. Applicants for directional signing will furnish to the department, on request, information relating to the limits of their advertising program, need of directional signing for the traveling public, number of public visits, and such other information as deemed appropriate to assure compliance with federal regulations and state law. The applicant or other representatives may appear before the Idaho Transportation Board in case of controversy. (3-31-22)

e. The applicant of community or bypassed community official signs will furnish the department the same information required in Subsection 340.01.c of this rule. (3-31-22)

02. Permits. (3-31-22)

a. Permit application forms may be secured at any ~~office of the~~ Idaho Transportation Department, ~~Division of Highways~~ District Office. (3-31-22)()

b. Permits will be issued annually expiring on December 31 each year, but can be issued for a period greater than one (1) year as a matter of convenience. (3-31-22)

c. The initial permit application fee is ten dollars (\$10) with an annual renewal fee of three dollars (\$3). The initial application fee is nonrefundable. A fee ~~shall~~ will not be prorated ~~for a fraction of a year~~ or be refunded for the balance of a permit period if the sign is removed. (3-31-22)()

d. A permit ~~shall~~ will not be issued until the sign has been approved by the department. A valid permit may be transferred to another person or jurisdiction upon written notice to the department. (3-31-22)()

e. A permit ~~shall~~ will not be issued for a sign located adjacent to a fully-controlled access highway or freeway unless it has been determined that access to the sign can be obtained without violating the access control provisions of the highway. The department will cancel a permit and require removal of the sign if it is found that the sign has been erected, maintained or serviced from the highway right-of-way at those locations where the department has acquired rights of access to the highway or rights of access have not accrued to the abutting property. In addition, the department may recover from the sign owner or person erecting, maintaining or servicing the sign, the amount of damage of landscaping, sodding, fencing, ditching or other highway appurtenances resulting from such acts. (3-31-22)()

f. The permit can be revoked by the state if the department determines that the applicant has knowingly supplied false or misleading information in his application for a permit or permit renewal. (3-31-22)

g. Service club, religious notice, and community official signs will require a permit but the fees will be waived. For permit purposes, service club and religious notice structures may have more than one (1) face but not more than six (6) faces. (3-31-22)()

341. -- 999. (RESERVED)

IDAPA 39 – IDAHO TRANSPORTATION DEPARTMENT

39.03.65 – RULES GOVERNING TRAFFIC MINUTE ENTRIES

DOCKET NO. 39-0365-2401 (ZBR CHAPTER REWRITE)

NOTICE OF RULEMAKING – PROPOSED RULE

AUTHORITY: In compliance with Section 67-5221(1), Idaho Code, notice is hereby given that this agency has initiated proposed rulemaking procedures. The action is authorized pursuant to Sections 49-201(1) and 49-202(22), Idaho Code.

PUBLIC HEARING SCHEDULE: Public hearing(s) concerning this rulemaking will be scheduled if requested in writing by twenty-five (25) persons, a political subdivision, or an agency, not later than October 16, 2024.

The hearing site(s) will be accessible to persons with disabilities. Requests for accommodation must be made not later than five (5) days prior to the hearing, to the agency address below.

DESCRIPTIVE SUMMARY: The following is a nontechnical explanation of the substance and purpose of the proposed rulemaking:

This rule establishes the procedures for making traffic minute entries regulating speed zoning, parking, traffic control devices, and the selective exclusion of traffic on the State Highway System. This rule was reviewed in accordance with the agency's Zero-Based Regulation review schedule. The proposed edits remove minor provisions that are no longer applicable.

FEE SUMMARY: The following is a specific description of the fee or charge imposed or increased: N/A.

FISCAL IMPACT: The following is a specific description, if applicable, of any negative fiscal impact on the state general fund greater than ten thousand dollars (\$10,000) during the fiscal year resulting from this rulemaking: N/A.

NEGOTIATED RULEMAKING: Pursuant to Section 67-5220(1), Idaho Code, negotiated rulemaking was conducted. The Notice of Intent to Promulgate Rules - Negotiated Rulemaking was published in the July 3, 2024, Idaho Administrative Bulletin, [Vol. 24-7, pages 273-274](#).

INCORPORATION BY REFERENCE: Pursuant to Section 67-5229(2)(a), Idaho Code, the following is a brief synopsis of why the materials cited are being incorporated by reference into this rule: N/A.

ASSISTANCE ON TECHNICAL QUESTIONS, SUBMISSION OF WRITTEN COMMENTS: For assistance on technical questions concerning the proposed rule, contact Brendan Floyd at 208-334-8474.

Anyone may submit written comments regarding this proposed rulemaking. All written comments must be directed to the undersigned and must be delivered on or before October 23, 2024.

DATED this 30th day of August, 2024.

Brendan Floyd
Policy Specialist
Idaho Transportation Department
11331 W. Chinden Blvd.
Boise, ID 83714
208-334-8474
Brendan.floyd@itd.idaho.gov

THE FOLLOWING IS THE PROPOSED TEXT OF DOCKET NO. 39-0365-2401
(ZBR Chapter Rewrite)

39.03.65 – RULES GOVERNING TRAFFIC MINUTE ENTRIES

000. LEGAL AUTHORITY.

This rule adopted under the authority of Sections 49-201 and 49-202, Idaho Code. (3-31-22)

001. ~~TITLE AND SCOPE~~PURPOSE.

This rule ~~is titled IDAPA 39.03.65, "Rules Governing Traffic Minute Entries," and~~ establishes the procedures for making Traffic Minute Entries regulating speed zoning, parking, traffic control devices, and the selective exclusion of traffic on the State Highway System. (3-31-22)()

002. -- 009. (RESERVED)

010. DEFINITIONS.

01. Traffic Minute Entries. Official entries made to Department records regulating traffic on the State Highway System. (3-31-22)

011. -- 099. (RESERVED)

100. GENERAL PROVISIONS.

01. Preparation. Traffic Minute Entries (except for temporary speed zones ~~and flashing beacons with warning signs~~) ~~shall~~ will be prepared by the Traffic Section for approval by the Department Director, State Highway Administrator, or the Chief of Highway Operations. (3-31-22)()

02. Requests. Each request for a Traffic Minute Entry ~~shall~~ will indicate: (3-31-22)()

a. The location regulated by the Traffic Minute Entry; (3-31-22)

b. The basis for the request; and (3-31-22)

c. Traffic and engineering study of operational characteristics and observations that support the Traffic Minute Entry. (3-31-22)

03. Temporary Regulations. Temporary traffic regulations for construction or maintenance zones ~~and flashing beacons with warning signs~~ ~~shall~~ will be initiated, monitored, corrected, and deleted by written approval of the appropriate District Engineer. (3-31-22)()

04. Unresolved Differences. Traffic Minute Entry worksheets regulating traffic on the State Highway System within incorporated cities should have the concurrence of the appropriate local officials. Unresolved differences regarding Traffic Minute Entries ~~shall~~ will be documented by the Traffic Section and presented to the Transportation Board for resolution. (3-31-22)()

101. -- 199. (RESERVED)

200. REQUIRED ENTRIES.

Traffic Minute Entries ~~shall~~ will be made for the following types of traffic regulations on the State Highway System: (3-31-22)()

- 01. Limits.** (3-31-22)
 - a. Permanent speed limits. (3-31-22)
 - b. Bridge limits (allowable gross loads). (3-31-22)
- 02. Parking.** (3-31-22)
 - a. Rural parking restrictions. (3-31-22)
 - b. Approval of angle parking on state highways through cities. (3-31-22)
- 03. Traffic Control.** (3-31-22)
 - ~~a. Traffic control signals and flashing intersection beacons at locations where there are no cooperative agreements between ITD and local authorities. (3-31-22)~~
 - ~~b. Flashing beacons with warning signs approved by District Engineer. (3-31-22)~~
 - ~~c. Exceptions to placing stop signs at passively protected railroad crossings. (3-31-22)~~
 - ~~d. Selective exclusion of vehicles on controlled-access highways. (3-31-22)~~
- 04. Other Entries.** Temporary construction, maintenance, and emergency regulations approved by the District Engineer. (3-31-22)

201. -- 299. (RESERVED)

300. PARKING ON STATE HIGHWAYS WITHIN CITIES.

Parking prohibitions and regulations on the State Highway System within incorporated cities ~~shall~~ will be approved by the city and the ITD Traffic Section and ~~shall~~ will be covered by a local ordinance unless provided for by a cooperative maintenance or construction agreement. Unresolved differences between incorporated cities and ITD ~~shall~~ will be presented to the Transportation Board for final resolution. (3-31-22)()

301. -- 999. (RESERVED)

IDAPA 43 – IDAHO OILSEED COMMISSION
43.01.01 – RULES GOVERNING THE IDAHO OILSEED COMMISSION
DOCKET NO. 43-0101-2401 (ZBR CHAPTER REWRITE)
NOTICE OF RULEMAKING – PROPOSED RULE

AUTHORITY: In compliance with Section 67-5221(1), Idaho Code, notice is hereby given that this agency has initiated proposed rulemaking procedures. The action is authorized pursuant to Section 22-4710, 22-4717, and 22-4718 Idaho Code.

PUBLIC HEARING SCHEDULE: A public hearing concerning this rulemaking will be held as follows:

43.01.01 – Rules Governing the Idaho Oilseed Commission
Thursday, October 3, 2024 – 10:00 a.m. - 11:30 a.m. (MT) Idaho Oilseed Commission Office 55 SW 5th Ave, Suite 100 Meridian, ID 83642

Additionally, the meeting will be held virtually. For virtual meeting links please contact Patxi Larrocea-Phillips at patxi@amgidaho.com.

The hearing site will be accessible to persons with disabilities. Requests for accommodation must be made not later than five (5) days prior to the hearing, to the agency address below.

DESCRIPTIVE SUMMARY: The following is a nontechnical explanation of the substance and purpose of the proposed rulemaking:

These rules are being presented for authorization as part of the Idaho Oilseed Commission’s plan to review its rules every 5 years. There are no specific rulemaking changes planned by the Idaho Oilseed Commission at this time except for evaluation and amendment consistent with the Governor’s [Zero-Based Regulation Executive Order](#). It is anticipated that rulemaking stakeholders will propose and advocate for rulemaking changes as part of the negotiated rulemaking process. The Idaho Oilseed Commission intends to carefully consider all changes presented by the public and may propose certain changes so long as they are consistent with the rules’ statutory authority and the Governor’s Executive Order.

FEE SUMMARY: The following is a specific description of the fee or charge imposed or increased: There is not a fee associated with this rulemaking.

FISCAL IMPACT: The following is a specific description, if applicable, of any negative fiscal impact on the state General Fund greater than ten thousand dollars (\$10,000) during the fiscal year as a result of this rulemaking: There is no fiscal impact associated with this rulemaking.

NEGOTIATED RULEMAKING: Pursuant to Section 67-5220(1), Idaho Code, negotiated rulemaking was conducted. The Notice of Intent to Promulgate Rules - Negotiated Rulemaking was published in the August 7, 2024 Idaho Administrative Bulletin, [Vol. 24-8, pg. 191](#).

INCORPORATION BY REFERENCE: Pursuant to Section 67-5229(2)(a), Idaho Code, the following is a brief synopsis of why the materials cited are being incorporated by reference into this rule: There are no materials incorporated by reference associated with this rulemaking.

ASSISTANCE ON TECHNICAL QUESTIONS, SUBMISSION OF WRITTEN COMMENTS: For assistance

on technical questions concerning the proposed rule, contact Patxi Larrocea-Phillips at patxi@amgidaho.com.

Anyone may submit written comments regarding this proposed rulemaking. All written comments must be directed to the undersigned and must be delivered on or before November 1, 2024.

DATED this 30th day of August, 2024.

Patxi Larrocea-Phillips
Administrator
55 SW 5th Ave, Suite 100
Meridian, ID 83642
Phone: 208-888-0988
Email: patxi@amgidaho.com

THE FOLLOWING IS THE PROPOSED TEXT OF DOCKET NO. 43-0101-2401
(ZBR Chapter Rewrite)

43.01.01 – RULES GOVERNING THE IDAHO OILSEED COMMISSION

000. LEGAL AUTHORITY.

~~The Idaho Oilseed Commission (hereinafter “Commission”) promulgates these rules implementing the provisions of Title 22, Chapter 47, Idaho Code~~ Section 22-4710, Idaho Code. (3-15-22)()

002. -- 009. (RESERVED)

010. FIRST PURCHASER RULES.

01. Designated Quarters. ~~In accordance with Section 22-4716, Idaho Code, the Commission has designated the quarters (three (3) month periods) for the purpose of collecting the tax imposed by such statute as follows~~ All tax payments and completed documents are due on or before the fifteenth of the first month of each quarter ~~The quarters for payment of tax are:~~ (3-15-22)()

a. ~~The Commission’s first quarter will begin on the first day of July and end the thirtieth day of September. The first quarter tax is due on or before the fifteenth day of October~~ First Quarter: July 1 through September 30. (3-15-22)()

b. ~~The Commission’s second quarter will begin on the first day of October and end the thirty first day of December. The second quarter tax is due on or before the fifteenth day of January~~ Second Quarter: October 1 through December 31. (3-15-22)()

c. ~~The Commission’s third quarter will begin on the first day of January and end the thirty first day of March. The third quarter tax is due on or before the fifteenth day of April~~ Third Quarter: January 1 through March 31. (3-15-22)()

d. ~~The Commission’s fourth quarter will begin on the first day of April and end the thirtieth day of June. The fourth quarter tax is due on or before the fifteenth day of July~~ Fourth Quarter: April 1 through June 30. (3-15-22)()

02. Oilseed Tax Invoice (Form Number 1). Pursuant to Section 22-4719, Idaho Code, the first purchaser of oilseed is required to complete and send the Oilseed Tax Invoice (Form Number 1) to the Commission

~~office each and every quarter on or before the dates specified in these rules. Form Number 1 shall be on official forms as prescribed by the Commission and be provided to the first purchaser by the Commission and, at a minimum, require the following legible information: (3-15-22)~~

- ~~a. The date of purchases and tax reporting period. (3-15-22)~~
- ~~b. The name and address of the oilseed seller and purchaser. (3-15-22)~~
- ~~c. The net weight of the oilseed sold in pounds or hundredweights. (3-15-22)~~
- ~~d. The total amount of tax deducted from Idaho oilseed producers by the purchaser. (3-15-22)~~
- ~~e. The total amount of tax due the Commission. (3-15-22)~~

032. Late Payment Penalty. Per Section 22-4716(4), Idaho Code, any person or firm who makes payment to the Commission at a date later than prescribed by law, is subject to a late payment penalty of twelve percent (12%) per annum on the amount due. (3-15-22)

~~011.—499. (RESERVED)~~

500. REFUND APPLICATIONS.

~~01. Assessment Refund.~~ In accordance with Section 22-4717, Idaho Code, any seller may request from the Commission in writing, within thirty (30) days after payment thereof, a refund of all or any portion of an assessment levied on oilseed and paid by such seller. Sellers requesting an oilseed assessment refund, as specified in Section 22-4717, Idaho Code, are required to complete and return a refund application form (Form Number 2) to the Commission office no later than thirty (30) days after payment of the assessment. Form Number 2 will be available through the Commission office. Written requests for refund application forms must be sent to the Commission office. (3-15-22)

~~02. Refund Application Form Number 2.~~ Form Number 2 shall, at a minimum, require the following information from the applicant: (3-15-22)

- ~~a. The applicant's name and address. (3-15-22)~~
- ~~b. The applicant's federal tax identification number. (3-15-22)~~
- ~~c. The first purchaser or lender who deducted the assessment from the applicant's settlement. (3-15-22)~~
- ~~d. The applicant's date of settlement. (3-15-22)~~
- ~~e. The hundredweight of oilseed sold by the applicant. (3-15-22)~~
- ~~f. The dollar amount of oilseed assessment deducted from the applicant's settlement. (3-15-22)~~

~~g. The applicant shall enclose evidence with the application proving the oilseed assessment was deducted by providing a copy of the invoice (Form Number 1) for which the refund is claimed. In the absence of a copy of the invoice, the Commission may, but is not bound to, accept other satisfactory evidence of payment. (3-15-22)~~

~~501-011. -- 999. (RESERVED)~~

IDAPA 47 – DIVISION OF VOCATIONAL REHABILITATION
47.01.01 – RULES GOVERNING VOCATIONAL REHABILITATION SERVICES
DOCKET NO. 47-0101-2401
NOTICE OF RULEMAKING – PROPOSED RULE

AUTHORITY: In compliance with Section 67-5221(1), Idaho Code, notice is hereby given that this agency has initiated proposed rulemaking procedures. The action is authorized pursuant to Sections 33-2303 and 33-6306, Idaho Code.

PUBLIC HEARING SCHEDULE: Public hearing(s) concerning this rulemaking will be scheduled if requested in writing by twenty-five (25) persons, a political subdivision, or an agency, not later than October 16, 2024.

The hearing site(s) will be accessible to persons with disabilities. Requests for accommodation must be made not later than five (5) days prior to the hearing, to the agency address below.

DESCRIPTIVE SUMMARY: The following is a nontechnical explanation of the substance and purpose of the proposed rulemaking:

During the spring and summer of 2024, the Division of Vocational Rehabilitation has been engaged in a federal compliance review. As part of this review, it was identified that IDAPA 47.01.01 is in need of minor revisions.

The proposed removal of language specifying that services must be related to a primary individual plan in subsections 203.01.c and 203.02.c and removal of Subsection 206.04, regarding employment maintenance, serve to ensure that the rule is again compliant with federal regulations. Section 33-2303, Idaho Code and the Rehabilitation Act of 1973, as amended by the Workforce Innovation and Opportunity Act (WIOA). (Public Law 113-128).

FEE SUMMARY: The following is a specific description of the fee or charge imposed or increased: NA.

FISCAL IMPACT: The following is a specific description, if applicable, of any negative fiscal impact on the state General Fund greater than ten thousand dollars (\$10,000) during the fiscal year resulting from this rulemaking: NA.

NEGOTIATED RULEMAKING: Pursuant to Section 67-5220(2), Idaho Code, negotiated rulemaking was not conducted because the rulemaking was due to necessary realignment to federal regulations that are required regardless of negotiated rulemaking.

INCORPORATION BY REFERENCE: Pursuant to Section 67-5229(2)(a), Idaho Code, the following is a brief synopsis of why the materials cited are being incorporated by reference into this rule: NA

ASSISTANCE ON TECHNICAL QUESTIONS, SUBMISSION OF WRITTEN COMMENTS: For assistance on technical questions concerning the proposed rule, contact Nicholas Wagner at rules@edu.idaho.gov or (208)-488-7586.

Anyone may submit written comments regarding this proposed rulemaking. All written comments must be directed to the undersigned and must be delivered on or before October 23, 2024.

DATED this 16th day of August, 2024.

Nicholas Wagner
Administrative Rules Coordinator
Idaho State Board of Education
650 W State St.
PO Box 83720
Boise, Idaho 83720-0037
Phone: (208)488-7586, fax: (208)334-2632

47.01.01 – RULES GOVERNING VOCATIONAL REHABILITATION SERVICES

203. SEVERITY OF DISABILITY.

At the time a customer is determined eligible for vocational rehabilitation services, a determination of the severity of disability, as it relates to employment, will also be determined. A priority category assignment will be determined for all eligible individuals, in one (1) of the following categories: (4-6-23)

01. Priority Category 1 - Eligible Individuals with the Most Significant Disabilities (MSD). (4-6-23)

- a. Meets criteria established for a customer with a significant disability; and (4-6-23)
- b. Experiences a severe physical and/or mental impairment that seriously limits three (3) or more functional categories (such as mobility, work skills, self-care, interpersonal skills, communication, self-direction or work tolerance) in terms of an employment outcome; and (4-6-23)
- c. Requires multiple ~~primary Individualized Plan for Employment (IPE)~~ services over an extended period of time. (4-6-23)()

02. Priority Category 2 - Eligible Individuals with Significant Disabilities (SD). (4-6-23)

- a. Meets the criteria for a customer with no significant disability; and (4-6-23)
- b. Experiences a severe physical and/or mental impairment that seriously limits one (1) or more functional categories (such as mobility, work skills, self-care, interpersonal skills, communication, self-direction or work tolerance) in terms of an employment outcome; and (4-6-23)
- c. Requires multiple ~~primary IPE~~ services over an extended period of time. (4-6-23)()

03. Priority Category 3 - All other Eligible Individuals with Disabilities (D). (4-6-23)

- a. Has a physical or mental impairment; and (4-6-23)
- b. Impairment constitutes or results in a substantial impediment to employment; and (4-6-23)
- c. Who can benefit in terms of an employment outcome from the provision of vocational rehabilitation services. (4-6-23)

(BREAK IN CONTINUITY OF SECTIONS)

206. ORDER OF SELECTION.

01. Order of Selection. When the Division cannot provide the full range of vocational rehabilitation services to all eligible customers because of fiscal or personnel capacity constraints, the agency will enter an order of selection. The order of selection will be based on the following requirements: (4-6-23)

- a. Students with disabilities, as defined by 34 CFR 361.5(c)(51), who received pre-employment transition services prior to eligibility determination and assignment to a disability priority category will continue to receive such services. (4-6-23)
- b. All customers who have an Individualized Plan for Employment will continue to be served.

(4-6-23)

02. Priority Status. Priority will be given to eligible individuals with the most significant disabilities, followed by those with significant disabilities, and finally those eligible individuals with disabilities. All eligible customers will be assigned to one (1) of the priority categories as outlined in Section 203 of these rules. (4-6-23)

03. When Unable to Serve Eligible Individuals. If the Division cannot serve all eligible individuals within a given priority category, individuals will be released from the statewide waitlist based on disability priority category and date of application. (4-6-23)

~~**04. Employment Maintenance.** The Division will serve individuals who are in immediate jeopardy of losing their employment and who require specific services or equipment to maintain employment, regardless of severity of disability category assignment, in accordance with 34 CFR 361.36.a(3)(v). (4-6-23)~~

IDAPA 50 – COMMISSION OF PARDONS AND PAROLE
50.01.01 – RULES OF THE COMMISSION OF PARDONS AND PAROLE
DOCKET NO. 50-0101-2401
NOTICE OF RULEMAKING – TEMPORARY AND PROPOSED RULE

EFFECTIVE DATE: The effective date of the temporary rule is July 1, 2024.

AUTHORITY: In compliance with Sections 67-5221(1) and 67-5226, Idaho Code, notice is hereby given that this agency has adopted a temporary rule, and proposed rulemaking procedures have been initiated. The action is authorized pursuant to Section(s) 20-1004 Idaho Code.

PUBLIC HEARING SCHEDULE: Public hearing(s) concerning this rulemaking will be scheduled if requested in writing by twenty-five (25) persons, a political subdivision, or an agency, not later than October 16, 2024.

The hearing site(s) will be accessible to persons with disabilities. Requests for accommodation must be made not later than five (5) days prior to the hearing, to the agency address below.

DESCRIPTIVE SUMMARY: The following is the required finding and concise statement of its supporting reasons for adopting a temporary rule and a nontechnical explanation of the substance and purpose of the proposed rulemaking:

This rule is being adopted due to the change in law and the passing of H.B. 600. This changes the time frame in which a person convicted of Assault and Battery and Attempted Strangulation can apply for a pardon.

TEMPORARY RULE JUSTIFICATION: Pursuant to Section(s) 67-5226(1)(b), Idaho Code, the Governor has found that temporary adoption of the rule is appropriate for the following reasons:

This rule is being adopted due to the change in the law during the 2023-2024 legislative session.

FEE SUMMARY: The following is a specific description of the fee or charge imposed or increased: N/A.

FISCAL IMPACT: The following is a specific description, if applicable, of any negative fiscal impact on the state General Fund greater than ten thousand dollars (\$10,000) during the fiscal year:

There will be no negative impact on the state General Fund.

NEGOTIATED RULEMAKING: Pursuant to Section 67-5220(2), Idaho Code, negotiated rulemaking was not conducted because of the change in the law.

INCORPORATION BY REFERENCE: Pursuant to Section 67-5229(2)(a), Idaho Code, the following is a brief synopsis of why the materials cited are being incorporated by reference into this rule: N/A.

ASSISTANCE ON TECHNICAL QUESTIONS, SUBMISSION OF WRITTEN COMMENTS: For assistance on technical questions concerning the temporary and proposed rule, contact Mary Schoeler (208) 334-2520.

Anyone may submit written comments regarding the proposed rulemaking. All written comments must be directed to the undersigned and must be delivered on or before October 23, 2024.

DATED this 1st day of July, 2024.

Ashley Dowell
Executive Director
Idaho Commission of Pardons and Parole
3056 Elder St.
Boise, ID 83705
(208)-334-2520

**THE FOLLOWING IS THE TEMPORARY RULE AND THE PROPOSED TEXT
OF DOCKET NO. 50-0101-2401
(Only Those Sections With Amendments Are Shown.)**

50.01.01 – RULES OF THE COMMISSION OF PARDONS AND PAROLE

550. PARDON.

A pardon may be considered for a person convicted of any misdemeanor or felony crime. A pardon does not expunge or remove the crime from the applicant's criminal history. (7-1-24)

01. General. An application for a pardon may not be considered until a period of time has elapsed since the applicant's discharge from custody as defined below. (7-1-24)

a. Applications for pardon for non-violent and non-sex crimes may be submitted for consideration no sooner than five (5) years after the satisfaction of the sentence on the crime for which they are requesting a pardon. (7-1-24)

b. Applications for pardon for violent or sex crimes or other crimes against a person may be submitted for consideration no sooner than ten (10) years after the satisfaction of the sentence on the crime for which they are requesting a pardon. (7-1-24)

c. In addition to the provisions of (a) and (b), applications for pardon for vehicular manslaughter pursuant to Section 18-4006(3)(b), Idaho Code, felony Domestic Violence, pursuant to Section 18-918 Idaho Code, Attempted Strangulation pursuant to Section 18-923 Idaho Code or driving under the influence, including any violation of Sections 18-8004, 18-8004C, 18-8005 or 18-8006, Idaho Code, may be submitted for consideration no sooner than fifteen (15) years after that date which the applicant pled guilty to or was found guilty of such a crime. (7-1-24)(7-1-24)T

d. A pardon application will not be considered while an offender is incarcerated or on supervision. (7-1-24)

e. The Commission will determine whether a hearing will be granted and the applicant will be notified of the decision in writing. (7-1-24)

02. Application. A pardon application can be obtained from the Commission office or on the Commission website. (7-1-24)

a. The application must be completed and returned to the Commission office. (7-1-24)

i. The completed application must include the reasons why the pardon is requested. (7-1-24)

ii. The applicant may attach letters of recommendation or other documents to support the request. (7-1-24)

iii. The applicant must include copies of all court judgments and conviction documents, as well as police reports for each crime for which a pardon is requested. (7-1-24)

iv. A pardon may be requested only once during a twelve-month (12) period from the date of denial unless otherwise stated by the Commission. (7-1-24)

v. An application may not be considered if there is significant law enforcement contact since sentence or discharge. (7-1-24)

b. Upon receipt of the completed application and required documentation, eligible applications will be reviewed by the Commission. The Commission may request an investigation of the applicant by Commission staff. The report will contain the following: (7-1-24)

i. A criminal records check will be conducted to include any law enforcement contact since the release from supervision or incarceration. (7-1-24)

ii. The applicant's employment history since discharge from supervision or incarceration. (7-1-24)

iii. The applicant's willingness to fulfill the obligations of a law-abiding citizen, including family information, community involvement, volunteer service, hobbies, and related interests. (7-1-24)

iv. The applicant's employment and education status, including any professional or vocational achievements, training, and any additional information as deemed necessary or appropriate. (7-1-24)

v. Confirmation that all restitution and fines as ordered by the sentencing court are paid. (7-1-24)

vi. An interview with the applicant may be conducted and a summary of the interview provided. Said interview may be conducted in person or by electronic means. (7-1-24)

03. Hearing. The scheduling of a hearing is at the complete discretion of the Commission. If a pardon hearing is scheduled, the Commission will determine the date of the hearing. (7-1-24)

a. Notice of a pardon hearing shall be published in a newspaper of general circulation at least once a week for four (4) consecutive weeks immediately prior to the hearing. (7-1-24)

b. A copy of the publication will be mailed to the prosecuting attorney of the county from which the petitioner was sentenced. (7-1-24)

c. Victims of the offender will be notified in writing when a hearing is scheduled. (7-1-24)

d. Written notice of the hearing date, time, and location will be sent to the applicant at the address given on the application or as otherwise requested. (7-1-24)

i. The Commission shall make such appearance mandatory, or may deny the pardon. (7-1-24)

e. The applicant will be given written notice of the decision and such notice will be sent to the last known address. (7-1-24)

f. The decision and supporting documents regarding a pardon will be filed with the Secretary of State consistent with Section 20-1018, Idaho Code. (7-1-24)

Sections Affected Index

IDAPA 02 – IDAHO STATE DEPARTMENT OF AGRICULTURE

02.02.12 – Bonded Warehouse Rules

Docket No. 02-0212-2401 (ZBR Chapter Rewrite)

000. Legal Authority	16
001. Title And Scope	16
002. -- 009. (Reserved)	16
010. Definitions	16
011. (Reserved)	17
012. Licensing	17
013. -- 049. (Reserved)	17
050. Receipting	17
051. -- 079. (Reserved)	19
080. Forwarding Agricultural Commodities	19
081. -- 099. (Reserved)	19
100. Office Records	19
101. -- 129. (Reserved)	19
130. License Application And Conditions Of Issuance	20
131. Amount Of Bond, Irrevocable Letter Of Credit, Certificate Of Deposit, Or Single Bond	20
132. -- 149. (Reserved)	20
150. Warehouses To Be Kept Clean	20
151. -- 179. (Reserved)	21
180. Warehouseman Responsibilities	21
181. -- 199. (Reserved)	22
200. Insurance Settlement	22
201. -- 229. (Reserved)	22
230. Agricultural Commodities -- Warehouse Obligations	22
231. -- 299. (Reserved)	22
300. Financial Statements	22
301. -- 329. (Reserved)	23
330. Amending Tariff	23
331. -- 379. (Reserved)	23
380. License -- Duration	23
381. -- 399. (Reserved)	23
400. Insurance Deductible	23
401. -- 429. (Reserved)	23
430. Additional Bonding Requirements	23
431. -- 479. (Reserved)	23
480. Commodity Indemnity Fund	23
481. How Assessments Are To Be Calculated	24
482. Recordkeeping And Payment Schedule	24
483. Trust Funds	24
484. Penalties For Failure To Collect, Account For, Or Remit Assessments	25
485. Return Of Commodity Due To Failure	25
486. -- 500. (Reserved)	25
501. No Price Established (NPE) Contract Claims On The Fund	25
502. -- 999. (Reserved)	25
<i>02.02.14 – Rules for Weights and Measures</i>	
Docket No. 02-0214-2401	
004. Incorporation By Reference	27
005. Diesel, Biodiesel, And Gasoline Standards	28
0056. -- 009. (Reserved)	28

02.03.01 – Rules Governing Pesticide Management Plans for Ground Water Protection

Docket No. 02-0301-2401 (ZBR Chapter Rewrite)

000. Legal Authority.....	30
001. Title And Scope.....	30
002. Written Interpretations.....	30
003. Administrative Appeals.....	30
002. -- 003. (Reserved).....	30
004. Incorporation By Reference.....	30
005. Address, Office Hours, Telephone, Fax Numbers, Web Address.....	31
006. Public Records Act Compliance.....	31
0075. -- 009. (Reserved).....	31
010. Definitions.....	31
011. Abbreviations.....	32
0121. -- 049. (Reserved).....	32
050. Chemical Specific Pesticide Management Plans PMPs.....	32
051. -- 099100. (Reserved).....	33
100. Contents Of A Chemical Specific PMP.....	33
101. Management Plans Adopted By Rulemaking And Review.....	33
102. -- 149. (Reserved).....	34
150. Ground Water Quality Reference Points.....	34
151. -- 199. (Reserved).....	34
200. Response To A Pesticide Detection.....	34
201. -- 299. (Reserved).....	36
300. Ground Water Monitoring Programs.....	36
3010. -- 399. (Reserved).....	36
400. Determining Pesticide Area Boundaries.....	36
401. -- 409. (Reserved).....	37
410. Repealing Specific Pesticide Areas.....	37
411. -- 419. (Reserved).....	38
420. Advisory Committee.....	38
421. Pesticide Use And Record Keeping Requirements.....	39
42211. -- 999. (Reserved).....	39

02.04.03 – Rules Governing Animal Industry

Docket No. 02-0403-2401 (ZBR Chapter Rewrite)

000. Legal Authority.....	41
001. Title And Scope.....	41
002. -- 010. (Reserved).....	41
011. Abbreviations.....	41
012. -- 103. (Reserved).....	42
104. Incorporation By Reference.....	42
105. -- 109. (Reserved).....	42
110. Definitions.....	42
111. Abbreviations.....	44
112. -- 113. (Reserved).....	44
114. Samples For Official Regulatory Tests.....	45
115. Quarantine.....	45
1165. -- 119. (Reserved).....	45
120. Disinfection Of Premises, Buildings And Vehicles.....	45
121. -- 124. (Reserved).....	45
125. Transit Inspection.....	45
126. -- 129. (Reserved).....	46
130. Slaughtering Of Diseased Animals.....	46

131. -- 139. (Reserved).....	46
140. Inspection Of Animals.....	46
141. -- 144. (Reserved).....	46
145. Certificates Of Veterinary Inspection.....	46
146. -- 149. (Reserved).....	46
150. State And Federal Seals.....	46
151. Notification Of Broken Seals.....	46
152. Livestock Identification Removal.....	46
153. -- 199. (Reserved).....	47
200. Artificial Insemination.....	47
201. -- 209. (Reserved).....	47
210. Cancer Eye - Epithelioma.....	47
211. Epithelioma -- Public Livestock Markets.....	47
212. -- 219. (Reserved).....	48
220. Rabies.....	48
221. -- 229. (Reserved).....	48
230. Biologicals.....	48
231. -- 239. (Reserved).....	48
240. Poultry And Ratites.....	48
241. Record Requirements.....	48
242. Inspections.....	48
243. NPIP Certificates Of Participation.....	49
244. -- 249. (Reserved).....	49
250. Equidae -- Equine Infectious Anemia.....	49
251. EIA Is A Reportable Disease.....	49
252. EIA Infected Animals.....	49
253. Disposition Of EIA Reactors.....	49
254. Isolation Of EIA Reactors.....	50
255. Identification Of EIA Reactors.....	50
256. Exposed Equidae.....	50
257. Extended Validity Equine Certificates.....	50
258. -- 299. (Reserved).....	50
300. Foreign Animal And Reportable Diseases.....	50
301. Foreign Animal And Reportable Diseases: Multiple Species.....	50
302. Foreign Animal And Reportable Diseases: Avian Diseases.....	51
303. Foreign Animal And Reportable Diseases: Bovine Diseases.....	51
304. Foreign Animal And Reportable Diseases: Cervidae Diseases.....	51
305. Foreign Animal And Reportable Diseases: Equine Diseases.....	52
306. Foreign Animal And Reportable Diseases: Fish Diseases.....	52
307. Foreign Animal And Reportable Diseases: Lagomorph Diseases.....	52
308. Foreign Animal And Reportable Diseases: Sheep And Goat Diseases.....	52
309. Foreign Animal And Reportable Diseases: Swine Diseases.....	52
310. -- 329. (Reserved).....	53
330. Notifiable Diseases.....	53
331. Notifiable Diseases: Mixed Species Diseases.....	53
332. Notifiable Diseases: Avian Diseases.....	53
333. Notifiable Diseases: Bovine Diseases.....	53
334. Notifiable Diseases: Equine Diseases.....	53
335. Notifiable Diseases: Fish Diseases.....	53
336. Notifiable Diseases: Lagomorph Diseases.....	53
337. Notifiable Diseases: Sheep And Goat Diseases.....	53
338. Notifiable Diseases: Swine Diseases.....	54

339. -- 359. (Reserved).....	54
360. Actinomycosis (Lump Jaw).....	54
361. -- 399. (Reserved).....	54
400. Garbage Feeding.....	54
4010. Pseudorabies -- Procedures For Control And Eradication.....	54
403. Vaccinated Swine.....	55
404. -- 419. (Reserved).....	55
420. Eradication Methods.....	55
421. -- 429. (Reserved).....	55
431. Identification Of Exposed Swine.....	55
432. -- 449. (Reserved).....	55
450. Qualified Pseudorabies-Negative Herds.....	55
451. -- 459. (Reserved).....	55
460. Cleaning And Disinfection.....	55
4601. -- 503. (Reserved).....	55
504. Incorporation By Reference.....	56
5054. -- 509. (Reserved).....	56
510. Definitions.....	56
511. -- 5201. (Reserved).....	57
521. Circumstances Of An Animal Health Emergency.....	57
522. Declaration Of An Animal Health Emergency.....	57
523. Quarantine Authority.....	57
5243. Utilization Of Vaccination In Animal Health Emergencies.....	57
5254. -- 52931. (Reserved).....	57
530. Quarantine Procedures For An Animal Health Emergency.....	57
531. Quarantine Area.....	58
532. Quarantine Area Security.....	58
533. Quarantine Area Bio-Security.....	58
534. Animal Movement In Quarantine Area.....	58
535. Sale Of Diseased Or Exposed Animals Not Allowed.....	58
5364. Exposure Of Another's Animals Not Allowed.....	58
5375. Movement Or Sale Of Animal Products.....	58
5386. -- 53940. (Reserved).....	58
540. Restrictions On Animals From Areas Or States Affected By Emergency Diseases.....	58
541. Animals In Transit At Time Of Declared Emergency.....	58
542. -- 549. (Reserved).....	58
550. Condemnation Of Infected, Exposed, Or Susceptible Animals.....	58
551. -- 559. (Reserved).....	59
560. Depopulation Of Animals.....	59
561. Method Of Depopulation.....	59
562. Time Limit For Depopulation.....	59
563. -- 569. (Reserved).....	59
570. Compensation For Appraised Animals.....	59
571. Compensation For Animals Destroyed.....	59
572. Appraisal Procedure For Animals Depopulated.....	59
573. Time Limit For Appraisal.....	59
5743. -- 579. (Reserved).....	59
580. Compensation For Labor Employed.....	59
581. Compensation For Property Destroyed.....	60
582. -- 589. (Reserved).....	60
590. Cleaning And Disinfection Of Premises.....	60
591. Cleaning And Disinfection Of Animal Conveyance.....	60

592. -- 999. (Reserved)..... 60

02.04.05 – Rules Governing Grade A Milk and Manufacture Grade Milk

Docket No. 02-0405-2401

104. Incorporation By Reference..... 63

02.04.15 – Rules Governing Beef Cattle Animal Feeding Operations

Docket No. 02-0415-2401

001. Scope..... 65

002. Incorporation By Reference..... 65

003. Definitions..... 66

004. Abbreviations..... 67

020. Wastewater Storage And Containment Facilities..... 67

032. Nutrient Management Records..... 68

0332. -- 039. (Reserved)..... 68

041. -- 049. (Reserved)..... 68

050. Administration Of IPDES Program..... 68

051. Compliance With Idaho Pollutant Discharge Elimination System Rules..... 68

052. -- 999. (Reserved)..... 68

02.04.19 – Rules Governing Domestic Cervidae

Docket No. 02-0419-2401

010. Definitions..... 70

500. Surveillance For CWD..... 73

501. Collection Of Samples For CWD Testing..... 74

504. Investigation Of CWD..... 74

505. Duration Of CWD Quarantine..... 74

02.05.01 – Rules Governing Produce Safety

Docket No. 02-0501-2401 (ZBR Chapter Rewrite)

000. Legal Authority..... 77

001. Title And Scope..... 77

002. Incorporation By Reference..... 77

003. – 00911. (Reserved)..... 77

010. Definitions..... 77

011. Abbreviations..... 78

012. Variance..... 78

013. – 999. (Reserved)..... 79

02.06.02 – Rules Governing Registrations and Licenses

Docket No. 02-0602-2401

104. Incorporation By Reference..... 81

404. Incorporation By Reference..... 82

504. Incorporation By Reference..... 82

02.06.09 – Rules Governing Invasive Species and Noxious Weeds

Docket No. 02-0609-2402

220. Noxious Weeds - Designations..... 84

Docket No. 02-0609-2404

135. Snake River Quarantine..... 90

02.06.33 – Organic Food Products Rules

Docket No. 02-0633-2401

004. Incorporation By Reference..... 92

IDAPA 02.08 – IDAHO SHEEP AND GOAT HEALTH BOARD*02.08.01 – Sheep and Goat Rules of the Idaho Sheep and Goat Health Board***Docket No. 02-0801-2401 (ZBR Chapter Rewrite)**

000. Legal Authority	94
001. Title And Scope	94
002. – 003. (Reserved)	94
004. Incorporation By Reference	94
005. -- 009. (Reserved)	95
010. Definitions	95
011. Abbreviations	97
012. Applicability	98
013. Additional Import Requirements	98
014. -- 099. (Reserved)	98
100. Sheep And Goat State Entrance Requirements	98
101. Permits	98
102. Scabies	99
103. Animals In Transit	99
104. Dairy Goats	99
105. Importation Of Scrapie Exposed, Suspect And High Risk Animals	99
106. Idaho Origin Sheep Interstate Grazing Permit	99
107. Interstate Shipments	100
108. -- 199. (Reserved)	100
200. Scrapie Program Standards, Scrapie Flock Certification, Scrapie Control And Eradication	100
2010. Identification Of Breeding Sheep and Goats	100
2021. Quarantine	101
2032. Restriction Of High-Risk Animals	101
2043. Movement Of Restricted Animals	101
2054. -- 399. (Reserved)	102
400. Condemnation And Destruction Of Diseased Animals Or Flocks	102
401. -- 499. (Reserved)	102
500. Indemnification	102
501. -- 599. (Reserved)	103
600. Cleaning And Disinfection	103
601. -- 699. (Reserved)	103
700. Sheep Assessments	103
701. Goat Assessments	103
702. -- 899. (Reserved)	103
900. Violations	103
901702. -- 999. (Reserved)	104

IDAPA 08 – STATE BOARD OF EDUCATION*08.01.13 – Rules Governing the Opportunity Scholarship Program***Docket No. 08-0113-2401**

101. Eligibility	106
102. -- 201. (Reserved)	107
202. Application Process	107
203. -- 299. (Reserved)	107
300. Selection Of Scholarship Recipients	107
301. Opportunity Scholarship Award	108
302. Continuing Eligibility	108
303. -- 399. (Reserved)	109
400. Responsibilities Of Eligible Idaho Postsecondary Educational Institutions	109

08.02.02 – Rules Governing Uniformity

Docket No. 08-0202-2401

007. Definitions.....	111
008. -- 011. (Reserved).....	113
012. Accredited Institution.....	113
008. -- 012. (Reserved).....	113
013. Certification Of Teachers Trained In Foreign Institutions.....	113
014. Certificates Issued To Applicants From Regionally Accredited Institutions.....	113
015. Idaho Educator Credential.....	113
016. Idaho Interim Certificate.....	121
021. Endorsements.....	122
042. Alternative Authorization.....	123
100. Official Vehicle For Approving Educator Preparation Programs.....	125

08.02.03 – Rules Governing Thoroughness

Docket No. 08-0203-2401

004. Incorporation By Reference.....	127
005. -- 006. (Reserved).....	128
007. Definitions.....	128
105. High School Graduation Requirements.....	130
109. Special Education.....	133
109. (Reserved).....	137

Docket No. 08-0203-2403

004. Incorporation By Reference.....	139
109. Special Education.....	140
109. (Reserved).....	144

08.04.01 – Rules of the Idaho Digital Learning Academy

Docket No. 08-0401-2401

102. Accountability.....	146
--------------------------	-----

IDAPA 09 – IDAHO DEPARTMENT OF LABOR

09.01.01 – Rules of Administrative Procedure of the Department of Labor

Docket No. 09-0101-2401 (ZBR Chapter Rewrite)

000. Legal Authority.....	148
001. Scope.....	148
002. (Reserved).....	148
003. Administrative Appeals.....	148
002. – 003. (Reserved).....	148
004. Payments To The Department.....	148
005. – 009. (Reserved).....	148
010. Definitions.....	148
011. – 014. (Reserved).....	148
015. Exemption From Attorney General Administrative Procedure Rules For Contested Cases.....	148
016. Reasons For Exemption From Attorney General's Administrative Procedure Rules.....	149
017. (Reserved).....	149
011. – 017. (Reserved).....	149
018. Declaratory Ruling Procedures.....	149
019. – 0245. (Reserved).....	149
025. Wage Claims Procedures.....	149
026. Dismissal Of Wage Claims For Lack Of Prosecution.....	149
027. Wage Claim And Employment Security Law Determinations.....	150
028. – 034. (Reserved).....	150
035. Appeals To Appeals Examiner – Form And Manner Of Filing Of Notices Of Appeal.....	150

036. Date Of Service Of Determinations.....	150
036. (Reserved)	150
037. Effect Of Delay or Error of Postal Service or Department.....	150
038. Dismissal If Filing Is Late.	151
039. – 044. (Reserved)	151
045. Conduct Of Appeals Hearing.	151
046. Communication With Appeals Staff.....	152
047. – 059. (Reserved)	153
060. Industrial Commission Review Of Appeals Examiner Decisions.....	153
061. – 064. (Reserved)	153
065. Judicial Review Of Wage Claim Decisions.....	153
0665. – 999. (Reserved)	153
09.01.30 – Unemployment Insurance Benefits Administration Rules	
Docket No. 09-0130-2401 (ZBR Chapter Rewrite)	
000. Legal Authority.	155
001. Scope.	155
002. Administrative Appeals.....	155
003. -- 009. (Reserved).....	155
010. Definitions.	155
011. -- 099. (Reserved).....	156
100. Able To Work.	156
101. -- 124. (Reserved).....	157
125. Alien Eligibility.	157
126. -- 149. (Reserved).....	157
150. Claimants With Disabilities.	157
151. -- 174. (Reserved).....	158
175. Available For Work.....	158
176. -- 199. (Reserved).....	161
200. Canceling Claims.	161
201. -- 224. (Reserved).....	161
225. Deceased Claimants.	161
226. -- 249. (Reserved).....	161
250. Determinations/Appellate Processes.	161
251. -- 274. (Reserved).....	161
275. Discharge.	161
276. -- 324. (Reserved).....	162
325. Employees Of Educational Institutions.....	162
326. -- 349. (Reserved).....	162
350. Extended Benefits.....	163
351. -- 374. (Reserved).....	163
375. Fully Employed/Not Unemployed.....	163
376. -- 399. (Reserved).....	163
400. Labor Dispute/Union Rules.	163
401. -- 424. (Reserved).....	164
425. New Claims/Additional Claims.	164
426. -- 449. (Reserved).....	166
450. Quit.....	166
451. -- 459. (Reserved).....	167
460. Professional Athletes Between Seasons.	167
461. -- 474. (Reserved).....	167
475. Refusal Of Work/Failure To Apply.....	167
476. -- 499. (Reserved).....	168

500. Reissuing Benefit Payments.....	168
501476. -- 524. (Reserved).....	169
525. Reportable Income.....	169
526. -- 549. (Reserved).....	170
550. Reporting Requirements.....	170
551. -- 574. (Reserved).....	171
575. Seeking Work.....	171
576. -- 599. (Reserved).....	173
600. Self-Employment.....	173
601. -- 649. (Reserved).....	173
650. Signatures Of Illiterates And Witnesses.....	173
65101. -- 674. (Reserved).....	173
675. Total Temporary Disability Alternate Base Period (TTD).....	173
676. -- 699. (Reserved).....	173
700. Partial Payments Of Amounts Owed The Department.....	173
701. -- 724. (Reserved).....	173
725. Recoveries.....	173
726. -- 749. (Reserved).....	174
750. Waiver Of Repayment.....	174
751. -- 999. (Reserved).....	174
09.01.35 – Unemployment Insurance Tax Administration Rules	
Docket No. 09-0135-2401 (ZBR Chapter Rewrite)	
000. Legal Authority.....	176
001. Scope.....	176
002. Administrative Appeals.....	176
003. -- 010. (Reserved).....	176
011. General Provisions.....	176
012. -- 039. (Reserved).....	177
040. Compromise Of Penalty And Civil Penalty.....	177
041. -- 050. (Reserved).....	178
051. Rounding Wages Reported On Contribution Report To Next Lower Dollar Amount.....	178
052. -- 055. (Reserved).....	178
056. Application Of Payments On Delinquent Accounts.....	178
057. -- 060. (Reserved).....	178
061. Definitions.....	178
062. Substance VS. Form.....	180
063. -- 080. (Reserved).....	180
081. Employer Records.....	180
082. -- 095. (Reserved).....	181
096. Employer Status Report.....	181
097. -- 105. (Reserved).....	181
106. Claims Of Exemption.....	181
107. Remuneration Paid Constitutes Both Taxable Wages And Excluded Amounts.....	181
108. Election To Exempt Corporate Officers.....	182
109. -- 110. (Reserved).....	183
111. Services Performed Part In Covered Employment And Part In Excluded Employment.....	183
112. Determining Status Of Worker.....	183
113. -- 130. (Reserved).....	186
131. Farm Commodity Ownership.....	186
132. Status.....	186
133. (Reserved).....	186
134. Professional Employer Organizations.....	186

135. -- 165. (Reserved)..... 187
 166. Field Operations Control..... 187
 167. -- 185. (Reserved)..... 188
 186. Accounting And Delinquency Control..... 188
 187. -- 220. (Reserved)..... 188
 221. Transfer Of Experience Rating..... 188
 222. -- 230. (Reserved)..... 189
 231. Experience Rating -- Qualifying Period..... 189
 232. -- 240. (Reserved)..... 189
 241. Board, Lodging, Meals..... 189
 242. -- 255. (Reserved)..... 190
 256. Determination Of Fair Value Of Remuneration For Personal Services..... 190
 257. -- 261. (Reserved)..... 190
 262. Determination Of Proper Quarter In Which To Assign And Report Wages..... 190
 263. Determination Of Reportable Quarters..... 190
 264. -- 999. (Reserved)..... 190

IDAPA 11 – IDAHO STATE POLICE / STATE FORENSIC LABORATORY

11.03.01 – Rules Governing Alcohol Testing

Docket No. 11-0301-2401 (ZBR Chapter Rewrite)

000. Legal Authority..... 192
 001. Scope..... 192
 002. Incorporation by Reference..... 192
 003. -- 009. (Reserved)..... 192
 010. Definitions And Abbreviations..... 192
 011. -- 012. (Reserved)..... 194
 013. Requirements For Laboratory Alcohol Analysis..... 194
 014. Requirements For Performing Breath Alcohol Testing..... 195
 015. -- 999. (Reserved)..... 199

IDAPA 13 – IDAHO DEPARTMENT OF FISH AND GAME

13.01.02 – Rules Governing Mandatory Education, Mentored Hunting, and Shooting Ranges

Docket No. 13-0102-2401

221. Bear Identification..... 202
 2212. – 249. (Reserved)..... 202

13.01.07 – Rules Governing Taking of Wildlife

Docket No. 13-0107-2401

250. Game Management Zone Descriptions..... 204
 501. – 9899. (Reserved)..... 205
 900. Federally Protected Wildlife..... 205
 901. – 999. (Reserved)..... 205

13.01.11 – Rules Governing Fish

Docket No. 13-0111-2401

011. Definitions – Conduct Of Fishing..... 207
 200. Fishing Methods And Gear..... 207

13.01.17 – Rules Governing Use of Bait for Hunting Big Game Animals

Docket No. 13-0117-2402

201. -- 9299. (Reserved)..... 210
 300. Use of Bait by a Grizzly Bear..... 210
 301. -- 999. (Reserved)..... 210

IDAPA 17 – INDUSTRIAL COMMISSION

17.01.01 – Administrative Rules Under the Worker's Compensation Law

Docket No. 17-0101-2301 (ZBR Chapter Rewrite)

000. Legal Authority.....	213
001. Title and Scope.....	213
001. (Reserved).....	214
002. Written Interpretations Incorporation By Reference.....	214
003 -- 009. (Reserved).....	214
010. Definitions.....	214
011. Abbreviations.....	217
012. Liberal Construction.....	218
0131. -- 200. (Reserved).....	218
201. Rule Governing 72-212(5) Exemptions.....	218
202. -- 300. (Reserved).....	219
301. Rules Governing Qualifications To Write Insurance Or Self-Insure.....	219
302. Rules Governing Continuing Requirements To Underwrite Insurance Or Self-insure.....	221
303. Rule Governing The Collection Of Premium Tax On Worker's Compensation Insurance Policies.....	225
304. Rule Governing Premium Tax Computation For Self-insured Employers.....	225
305. Requirements For Maintaining Idaho Worker's Compensation Claims Files.....	226
306. Rule Prohibiting Use Of Sick Leave Or Other Alternative Compensation.....	231
307. Rule Governing Reporting Indemnity And Medical Payments And Making Payment Of Industrial Special Indemnity Fund (ISIF) Assessment.....	232
308. -- 400. (Reserved).....	232
401. Rule Governing Computation Of Average Weekly Wage.....	232
402. Rule Governing Conversion Of Average of Multiple Impairment Ratings To "Whole Man" Standard.....	233
403. Rule Governing Compensation For Disability Due To Loss Of Teeth.....	233
404. Submission Of Medical Reports From Providers.....	233
405. Rule Governing Reimbursement For Travel Expenses.....	234
406. -- 500. (Reserved).....	234
501. Rule Governing Protection And Disclosure Of Rehabilitation Division Records.....	234
502. Rule Governing Reports Of Attorney Costs And Fees In Litigated Cases.....	235
503. -- 600. (Reserved).....	235
601. Submission Of FROI And SROI.....	235
602. Final reports.....	236
603. -- 800. (Reserved).....	236
801. Rule Governing Change Of Status Notice To Claimants.....	236
802. Rule Governing Approval Of Attorneys Fees.....	237
803. Medical Fees.....	238
804. -- 999. (Reserved).....	244

IDAPA 24 – DIVISION OF OCCUPATIONAL AND PROFESSIONAL LICENSES

24.03.01 – Rules of the State Board of Chiropractic Physicians

Docket No. 24-0301-2401 (ZBR Chapter Rewrite)

71003. -- 999. (Reserved).....	250
--------------------------------	-----

24.04.01 – Rules of the Board of Registration for Professional Geologists

Docket No. 24-0401-2401 (ZBR Chapter Rewrite, Fee Rule)

000. Legal Authority.....	253
001. Scope.....	253
002. -- 009. (Reserved).....	253
01002. Definitions.....	253

01103. -- 099. (Reserved) 254

100. Licensure 254

101. -- 199. (Reserved) 254

100200.General ProvisionsPractice Standards. 254

101201. -- 149399. (Reserved) 255

150400.Fees. 255

151. -- 199. (Reserved) 255

200. Application Procedures 255

201. -- 299. (Reserved) 256

300. Examinations. 256

301. -- 399. (Reserved) 257

400. Geologist In Training. 257

401. -- 999. (Reserved) 257

24.21.01 – Rules of the Idaho State Contractors Board

Docket No. 24-2101-2401 (ZBR Chapter Rewrite)

000. Legal Authority. 262

001. Scope. 262

002. -- 149099. (Reserved) 262

150100.ApplicationRegistration. 262

151. -- 164. (Reserved) 262

165. Additional Qualifications For Registration. 262

16601. -- 174399. (Reserved) 263

175400.Fees. 263

176401. -- 999. (Reserved) 263

24.39.10 – Rules of the Idaho Electrical Board

Docket No. 24-3910-2402

100. Licensure And Registration. 273

101. – 199. (Reserved) 274

200. Practice Standards. 274

501. – 999599. (Reserved) 277

600. Idaho Electrical Code. 277

601. – 999. (Reserved) 280

IDAPA 31 – IDAHO PUBLIC UTILITIES COMMISSION

31.41.01 – Customer Relations Rules for Telephone Corporations Providing Services in Idaho Subject to Customer Service Regulation by the Idaho Public Utilities Commission (The Telephone Customer Relations Rules)

Docket No. 31-4101-2401 (ZBR Chapter Rewrite)

000. Legal Authority (Rule 0). 284

001. Title And Scope (Rule 1). 284

002. Written Interpretations – Agency Guidelines (Rule 2). 284

003. Administrative Appeals (Rule 3). 284

002. -- 003. (Reserved) 284

004. (Reserved)Incorporation By Reference (Rule 4). 284

005. Definitions (Rule 5). 285

006. -- 007. (Reserved) 285

008. Exercise Of Rights By Customer (Rule 8). 285

009. Informal Complaints And Interpretation Of Rules (Rule 9). 286

009. (Reserved) 286

010. Conflict With Telephone Tariffs Or Price Lists (Rule 10). 286

011. Incorporation By Reference -- Code Of Federal Regulations (Rule 11). 286

0121. -- 099. (Reserved) 286

100.	Deposit Requirements -- LECS (Rule 100).	286
101.	Other Deposit Standards Prohibited (Rule 101).	287
102.	Explanation For Denial Of Service Or Requirement Of Deposit -- LECS (Rule 102).	287
103.	Amount Of Deposit -- LECS (Rule 103).	287
104.	Interest On Deposits (Rule 104).	287
105.	Return Of Deposit -- LECS (Rule 105).	287
106.	Transfer Of Deposit and Outstanding Balance (Rule 106).	288
107.	Records Of Deposits (Rule 107).	288
108.	Unclaimed Deposits And Advance Payments (Rule 108).	288
1098. -- 199.	(Reserved)	288
200.	Further Definition (Rule 200).	288
201.	Issuance Of Billing Statements -- Contents Of Bills -- Residential And Small Business Service (Rule 201).	289
202.	Due Date Of Bills -- Delinquent Bills (Rule 202).	290
203.	Billing Errors, Billing Under Incorrect Rates, Or Failure To Bill (Rule 203).	290
204.	Billing Prohibited -- Billing Disputes (Rule 204).	290
205.	Responsibility For Payment Of Residential Service Bills (Rule 205).	291
206. -- 299.	(Reserved)	292
300.	Explanation For Denial Of A Service To A Customer (Rule 300).	292
301.	Grounds For Denial Or Termination Of Local Exchange Service With Prior Notice (Rule 301).	292
302.	Grounds For Denial Or Termination Of A Service, Without Prior Notice (Rule 302).	292
303.	Requirements For Notice Before Termination Of Local Exchange Service (Rule 303).	293
304.	Contents Of Notice Of Intent To Terminate Local Exchange Service (Rule 304).	293
305.	Serious Illness Or Medical Emergency (Rule 305).	294
306.	Medical Facilities -- Shelter Care (Rule 306).	294
307.	Insufficient Grounds For Termination Of Local Exchange Service (Rule 307).	294
308.	Restrictions On Termination Of Local Exchange Service -- Opportunity To Avoid Termination Of Local Exchange Service (Rule 308).	295
309.	Payment Arrangements (Rule 309).	295
310.	Denial, Restriction, Modification, Or Termination Of Long-Distance Service Or Other Services (Rule 310).	296
311.	Cessation Of Service In A Service Area (Rule 311).	296
312. -- 399.	(Reserved)	297
400.	Complaint To Telephone Company (Rule 400).	297
401.	Complaint To Commission (Rule 401).	297
402.	Record Of Complaints (Rule 402).	298
403.	Telephone Company Response To Informal Complaints (Rule 403).	298
404. -- 499.	(Reserved)	298
500.	Quality Of Service (Rule 500).	298
501.	Response To Service Outage (Rule 501).	298
502.	Repair Service Standards (Rule 502).	299
503.	Paytelephone Emergency Access Required (Rule 503).	299
504.	Paytelephone Approved Instruments -- Operation Of Instruments (Rule 504).	299
505.	Paytelephone Emergency Numbers (Rule 505).	300
506.	Connection Of Pay Telephones (Rule 506).	300
507. -- 599.	(Reserved)	300
600.	Information To Customers (Rule 600).	300
601.	Access To Emergency Services (Rule 601).	301
602.	Request For Telephone Company Records (Rule 602).	301
603.	Automatic Recording (Rule 603).	301
603.	(Reserved)	301
604.	Public Notice (Rule 604).	301

605. Telephone Solicitations (Rule 605).....	301
605. (Reserved).....	301
606. Information, Price Lists Or Tariffs For Non-Local Exchange Service (Rule 606).....	301
607. Price Lists Or Tariff Filings (Rule 607).....	302
608. Form And Number Of Copies Of Price List Or Tariff (Rule 608).....	303
609. -- 699701. (Reserved).....	303
700. The Unauthorized Change Of A Customer's Telephone Company (Rule 700).....	303
701. Adoption Of Federal Slamming Regulations (Rule 701).....	303
702. State Procedures (Rule 702).....	303
703. -- 999. (Reserved).....	304

IDAPA 37 – IDAHO DEPARTMENT OF WATER RESOURCES**37.03.01 – Adjudication Rules****Docket No. 37-0301-2401 (ZBR Chapter Rewrite)**

000. Legal Authority.....	306
001. Title And Scope.....	306
002. -- 009. (Reserved).....	306
010. Definitions.....	306
011. Abbreviations.....	307
012. -- 024. (Reserved).....	308
025. General.....	308
026. -- 029. (Reserved).....	308
030. Flat Fees.....	308
031. -- 034. (Reserved).....	308
035. Variable Fees.....	308
036. -- 044. (Reserved).....	310
045. Amendment Fees.....	310
046. -- 049. (Reserved).....	310
050. Late Fees.....	310
051. -- 054. (Reserved).....	310
055. Refunds.....	310
056. -- 059. (Reserved).....	310
060. Sufficiency Of Claims.....	310
061. -- 064. (Reserved).....	316
065. Rejected And Returned Claims.....	316
066. -- 999. (Reserved).....	316

37.03.02 – Beneficial Use Examination Rules**Docket No. 37-0302-2401 (ZBR Chapter Rewrite)**

000. Legal Authority (Rule 0).....	318
001. Title And Scope (Rule 1).....	318
002. -- 008. (Reserved).....	318
009. Applicability (Rule 9).....	318
010. Definitions (Rule 10).....	319
011. Abbreviations.....	321
0121. -- 024. (Reserved).....	321
025. Authority Of Representative (Rule 25).....	321
026. -- 029. (Reserved).....	321
030. Qualification, Examination And Appointment Of Certified Water Right Examiner (Rule 30).....	321
031. -- 034. (Reserved).....	322
035. Examination For Beneficial Use (Rule 35).....	322
036. -- 039. (Reserved).....	326
040. Water Measurement (Rule 40).....	326

041. -- 044. (Reserved).....	327
045. Drawings, Map, And Schematic Diagram (Rule 45).....	327
046. -- 049. (Reserved).....	327
050. License Examination Fee (Rule 50).....	327
051. -- 054. (Reserved).....	328
055. Penalty (Rule 55).....	328
056. -- 999. (Reserved).....	328
37.03.03 – Rules and Minimum Standards for the Construction and Use of Injection Wells	
Docket No. 37-0303-2301 (ZBR Chapter Rewrite)	
000. Legal Authority.....	331
001. Title And Scope.....	331
002. Incorporation By Reference.....	332
0032. -- 009. (Reserved).....	332
010. Definitions.....	332
011. -- 014. (Reserved).....	338
015. Violations, Formal Notification And Enforcement.....	338
016. -- 019. (Reserved).....	339
020. Hearing Before The Water Resource Board.....	339
02111. -- 03419. (Reserved).....	339
03520. Classification Of Injection Wells.....	339
03621. -- 03924. (Reserved).....	342
04025. Authorizations, Prohibitions and Exemptions.....	342
04126. -- 06929. (Reserved).....	344
030. Class V Shallow Injection Well Requirements.....	344
031. -- 034. (Reserved).....	344
035. Class V Injection Well Requirements.....	344
036. -- 049. (Reserved).....	346
050. Class V Injection Well Requirements – Application Processing.....	346
051. (Reserved).....	348
052. Class V Injection Well Construction And Operation Requirements.....	348
053 - 054. (Reserved).....	350
055. Standards For the Quality of Fluids Injected into Class V Wells.....	350
056. (Reserved).....	351
057. Criteria for Location and Use of Class V Wells Requiring Permits.....	351
058. Monitoring, Record Keeping, and Reporting Requirements.....	352
058. -- 059. (Reserved).....	354
060. Hearing Before The IDAHO Water Resource Board.....	354
061. -- 069. (Reserved).....	354
070. Violations, Formal Notification And Enforcement.....	354
070. Class V: Criteria And Standards.....	354
071. -- 999. (Reserved).....	365
37.03.09 – Well Construction Standards Rules	
Docket No. 37-0309-2401 (ZBR Chapter Rewrite)	
000. Legal Authority (Rule 0).....	367
001. Title And Scope (Rule 1).....	367
002. -- 009. (Reserved).....	367
010. Definitions (Rule 10).....	367
011. -- 024. (Reserved).....	374
025. Construction Of Cold Ground Water Wells (Rule 25).....	374
026. -- 029. (Reserved).....	385
030. Construction Of Low Temperature Geothermal Resource Wells And Bonding (Rule 30).....	385
031. -- 034. (Reserved).....	388

035. Health Standards (Rule 35)..... 388

036. Owners Responsibilities For Well Use And Maintenance (Rule 36). 388

037. -- 039. (Reserved)..... 389

040. Areas Of Drilling Concern (Rule 40)..... 389

041. -- 044. (Reserved)..... 390

045. Drilling Permit Requirements (Rule 45)..... 390

046. -- 049. (Reserved)..... 391

050. Penalties (Rule 50)..... 391

051. -- 999. (Reserved)..... 391

37.03.11 – Rules for Conjunctive Management of Surface and Ground Water Resources

Docket No. 37-0311-2401

050. Areas Determined To Have A Common Ground Water Supply (Rule 50). 408

IDAPA 39 – IDAHO TRANSPORTATION DEPARTMENT

39.02.03 – Rules Governing Vehicle Dealer’s Principal Place of Business and Claims to the Idaho Consumer Asset Recovery Fund

Docket No. 39-0203-2401 (ZBR Chapter Rewrite)

000. Legal Authority. 412

001. Title And ScopePurpose. 412

002. -- 009. (Reserved)..... 412

010. Definitions. 412

011. -- 099. (Reserved)..... 413

100. General Provisions. 413

101. -- 199. (Reserved)..... 414

200. Idaho Consumer Asset Recovery Fund Control Board Administration. 414

201. -- 299. (Reserved)..... 415

300. Penalties. 415

3010. -- 999. (Reserved)..... 415

39.02.75 – Rules Governing Names on Drivers' Licenses and Identification Cards

Docket No. 39-0275-2401

001. Title And ScopePurpose. 417

002. -- 099. (Reserved)..... 417

100. General Provisions. 417

101. -- 199. (Reserved)..... 417

200. Criteria..... 417

201. -- 299. (Reserved)..... 419

300. Procedures..... 419

301. -- 999. (Reserved)..... 419

39.03.41 – Rules Governing Traffic Control Devices

Docket No. 39-0341-2401

000. Legal Authority. 421

001. Title And ScopePurpose. 421

002. -- 003. (Reserved)..... 421

004. Incorporation By Reference. 421

005. Availability Of The “Manual On Uniform Traffic Control Devices For Streets And Highways And Other Referenced Documents.” 442

006. -- 999. (Reserved)..... 442

39.03.60 – Rules Governing Outdoor Advertising, Accident Memorials, and Other Official Signs

Docket No. 39-0360-2401 (ZBR Chapter Rewrite)

000. Legal Authority. 444

001. Title And ScopePurpose. 444

002. -- 009. (Reserved).....	444
010. Definitions.....	444
011. -- 099. (Reserved).....	448
100. General.....	448
101. -- 109. (Reserved).....	449
110. Exemptions Authorized By Section 40-1904, Idaho Code.....	449
111. -- 119. (Reserved).....	449
120. Displays Located Within Zoned Or Unzoned Industrial, Business Or Commercial Areas.....	449
121. -- 129. (Reserved).....	451
130. Licenses.....	451
131. -- 139. (Reserved).....	451
140. Outdoor Advertising Permits.....	452
141. -- 149. (Reserved).....	453
150. Bonds Of Out-Of-State Permittees And Licensees.....	453
151. -- 199. (Reserved).....	453
200. General: Traffic Accident Memorials.....	453
201. Traffic Accident Memorial Permit.....	453
202. Physical Requirements.....	453
203. -- 214. (Reserved).....	453
215. Location.....	453
216. -- 219. (Reserved).....	454
220. Safety.....	454
221. -- 239. (Reserved).....	454
240. Maintenance.....	454
241. Compliance.....	454
242. -- 299. (Reserved).....	454
300. General: Standards For Community Official Signs.....	454
301. Standards For Directional Signs.....	455
302. -- 319. (Reserved).....	456
320. Lighting, Signs May Be Illuminated, Subject To The Following.....	456
321. -- 339. (Reserved).....	456
340. Administration.....	456
341. -- 999. (Reserved).....	457
39.03.65 – Rules Governing Traffic Minute Entries	
Docket No. 39-0365-2401 (ZBR Chapter Rewrite)	
000. Legal Authority.....	459
001. Title And Scope Purpose.....	459
002. -- 009. (Reserved).....	459
010. Definitions.....	459
011. -- 099. (Reserved).....	459
100. General Provisions.....	459
101. -- 199. (Reserved).....	459
200. Required Entries.....	459
201. -- 299. (Reserved).....	460
300. Parking On State Highways Within Cities.....	460
301. -- 999. (Reserved).....	460
IDAPA 43 – IDAHO OILSEED COMMISSION	
43.01.01 – Rules Governing the Idaho Oilseed Commission	
Docket No. 43-0101-2401 (ZBR Chapter Rewrite)	
000. Legal Authority.....	462
002. -- 009. (Reserved).....	462

010. First Purchaser Rules 462
011. -- 499. (Reserved) 463
500. Refund Applications 463
501011. -- 999. (Reserved) 463

IDAPA 47 – DIVISION OF VOCATIONAL REHABILITATION

47.01.01 – Rules Governing Vocational Rehabilitation Services

Docket No. 47-0101-2401

203. Severity Of Disability 465
206. Order Of Selection 465

IDAPA 50 – COMMISSION OF PARDONS AND PAROLE

50.01.01 – Rules of the Commission of Pardons and Parole

Docket No. 50-0101-2401

550. Pardon 468

LEGAL NOTICE

Summary of Proposed Rulemakings

PUBLIC NOTICE OF INTENT TO PROPOSE OR PROMULGATE NEW OR CHANGED AGENCY RULES

The following agencies of the state of Idaho have published the complete text and all required information concerning their intent to change or make new the following rules in the latest publication of the state Administrative Bulletin.

*The proposed rule public hearing request deadline is October 16, 2024, unless otherwise posted.
The proposed rule written comment submission deadline is October 23, 2024, unless otherwise posted.
(*Temp & Prop) indicates the rulemaking is both Temporary and Proposed.
(*PH) indicates that a public hearing has been scheduled.*

IDAPA 02 – DEPARTMENT OF AGRICULTURE PO Box 7249, Boise, ID 83707

02-0212-2401, Bonded Warehouse Rules. Zero-Based Regulation (ZBR) Rewrite clarifies procedures for licensing, collection and remittance of assessment, determining claim value, maintaining electronic records use of electronic scales, and remedies of the Department for non-compliance.

02-0214-2401, Rules for Weights and Measures. Amendment updates incorporated document that contains the specifications, tolerances, and other technical requirements for commercial weighing and measuring devices.

02-0301-2401, Rules Governing Pesticide Management Plans for Ground Water Protection. ZBR Rewrite clarifies procedure for testing and monitoring groundwater for pesticides and remedies of the Department for non-compliance.

02-0403-2401, Rules Governing Animal Industry. ZBR Rewrite clarifies procedures for: disease control of livestock and other animals into, within, and out of the state; prevention, control, and eradication of diseases among animals in the state; and Departmental remedies for non-compliance.

02-0405-2401, Rules Governing Grade A Milk and Manufacture Grade Milk. Updates include changes in incorporated federal code governing design, construction, production, manufacture, distribution, handling, storage, quality, analysis, and sale of safe and wholesome dairy products.

02-0415-2401, Rules Governing Beef Cattle Animal Feeding Operations. Removes redundant language now included in IDAPA 02.04.30, Rules Governing Environmental and Nutrient Management, for waste systems on beef cattle animal feeding operations.

02-0419-2401, Rules Governing Domestic Cervidae. Rulemaking complies with recent legislation making certain changes to the quarantine process, sampling protocols, and requirements for domestic cervidae operations while under quarantine.

02-0501-2401, Rules Governing Produce Safety. ZBR Rewrite clarifies procedures for administering the Food Safety Modernization Act and remedies for non-compliance for the growing, harvesting, packing, and holding of safe and unadulterated produce for human consumption.

02-0602-2401, Rules Governing Registrations and Licenses. Updates incorporated standardized regulations for Commercial Feed, Commercial Fertilizer, and Soil and Plant Amendments, refining definitions, technical terms, and other standards necessary for product regulation.

02-0609-2402, Rules Governing Invasive Species and Noxious Weeds. Changes reduce categorization of Turkish thistle from EDRR to Control category and add clarifying language for EDRR noxious weed list criteria.

02-0633-2401, Organic Food Products Rules. Updates incorporated CFR document, National Organic Program Regulations, governing the specifications, tolerances, and other technical requirements for maintaining organic accreditation.

IDAPA 02.08 – IDAHO SHEEP AND GOAT HEALTH BOARD 2118 W Airport Way, Boise, ID 83705

02-0801-2401, Sheep and Goat Rules of the Idaho Sheep and Goat Health Board. ZBR Rewrite governs:

prevention, control, and disease eradication procedures; interstate and intrastate movement; and assessment of fees to provide functional resources for sheep and goats in Idaho.

IDAPA 08 – STATE BOARD OF EDUCATION
PO Box 83720, Boise, ID 83720-0037

08-0113-2401, Rules Governing the Opportunity Scholarship Program. Changes reflect recent legislation and include: updating the credit completion minimums for scholarship renewal; new initial eligibility requirement restricting students from receiving simultaneous dual scholarship funds; and reinstating community colleges as eligible recipients of Opportunity Scholarship Funds.

08-0202-2401, Rules Governing Uniformity. Rulemaking comports with governing statute that provides for the development of a board-approved apprenticeship program by defining teacher certifications training requirements and program exit requirements before apprentices become eligible.

08-0203-2401, Rules Governing Thoroughness. Changes aim to modernize the traditional graduation system to better accommodate variable pathways and competency-based graduation plans for high school graduation requirements.

08-0401-2401, Rules of the Idaho Digital Learning Academy. Proposed language allows IDLA in collaboration with the local education agency to determine comprehensive final exam or final project assessment requirements for their students enrolled in IDLA courses.

IDAPA 09 – IDAHO DEPARTMENT OF LABOR
317 W 3rd St, Boise, ID 83702

09-0101-2401, Rules of Administrative Procedure of the Department of Labor. ZBR Rewrite details procedures for rulemaking, petitions for declaratory rulings, and determinations and appeals pursuant to the Employment Security Law, Claims for Wages Act, or other specified program.

09-0130-2401, Unemployment Insurance Benefits Administration Rules. ZBR Rewrite governs claims for unemployment insurance benefits.

09-0135-2401, Unemployment Insurance Tax Administration Rules. ZBR Rewrite specifies Department procedures and the rights and duties of employers under the Unemployment Insurance Program.

IDAPA 11 – IDAHO STATE POLICE \ STATE FORENSIC LABORATORY
700 S Stratford Dr, Meridian, ID 83642

***11-0301-2401, Rules Governing Alcohol Testing.** (*PH) ZBR Rewrite relates to the governance and operation of the Alcohol Testing Program and outlines requirements for laboratory alcohol analysis and for performing breath alcohol testing.

IDAPA 13 – IDAHO DEPARTMENT OF FISH AND GAME
PO Box 25, Boise, ID 83707

13-0102-2401, Rules Governing Mandatory Education, Mentored Hunting, and Shooting Ranges. (Temp & Prop) Rulemaking addresses a United States Fish and Wildlife Service recommendation to adopt a bear identification test to avoid take of grizzly bear by misidentification.

13-0107-2401, Rules Governing Taking of Wildlife. Rulemaking modifies four game management (elk) zones to align with changes presented in the agency's Idaho Elk Management Plan and clarifies that state regulatory actions do not authorize any person to violate federal laws relative to federally protected wildlife when there is not a valid federal take authorization.

13-0111-2401, Rules Governing Fish. Edits expand opportunities for spearfishing in Idaho and provides Commission authority through proclamation to determine seasons, fish species, and take limits for spearfishing.

IDAPA 17 – INDUSTRIAL COMMISSION
PO Box 83720, Boise, ID 83720-0041

***17-0101-2301, Administrative Rules Under the Worker's Compensation Law.** (*PH) ZBR Rewrite covers the administration and regulation of the Idaho Worker's Compensation Act, including, but not limited to: coverage requirements, benefits administration, medical fee schedule and process for medical fee disputes, reporting requirements, and claims administration requirements. Comment by 10/28/2024.

IDAPA 24 – DIVISION OF OCCUPATIONAL AND PROFESSIONAL LICENSES
PO Box 83720, Boise, ID 83720-0063

***24-0401-2401, Rules of the Board of Registration for Professional Geologists.** (*PH) ZBR Rewrite governs the

practice of geology in Idaho, including licensure, practice standards, and applicable fees.

***24-2101-2401, Rules of the Idaho State Contractors Board.** (*PH) ZBR Rewrite governs the practice and registration of construction and contractors in Idaho with associated fees.

***24-3910-2402, Rules of the Idaho Electrical Board.** (*PH) Proposed edits: modify definitions for Residential, Journeyman, and Master Electricians and Contractors; define continuing education criteria; clarify supervision practice standards; and update the Idaho Electrical Code.

IDAPA 26 – DEPARTMENT OF PARKS AND RECREATION

5657 Warm Springs Ave, Boise, ID 83716

26-0137-2401, Rules Governing Test Procedures and Instruments for Noise Abatement of Off Highway Vehicles. ZBR Repeal proposes to rescind rule chapter with the intent of placing regulations in Idaho statute.

IDAPA 31 – IDAHO PUBLIC UTILITIES COMMISSION

PO Box 83720 Boise, ID 83720-0074

31-4101-2401, Customer Relations Rules for Telephone Corporations Providing Services in Idaho Subject to Customer Service Regulation by the Idaho Public Utilities Commission (The Telephone Customer Relations Rules). ZBR Rewrite addresses areas of disagreement between provider companies and customers with regard to: deposits, guarantees, and billing; application for, denial of, and termination of service; complaints to telephone companies; billing for interrupted service; and certain customer information being provided to authorities.

IDAPA 37 – IDAHO DEPARTMENT OF WATER RESOURCES

PO Box 83720 Boise, ID 83720-0098

37-0301-2401, Adjudication Rules. ZBR Rewrite implements governing statutes for the filing of, and the collection of fees for, notices of claims to water rights acquired under state law in general adjudications.

37-0302-2401, Beneficial Use Examination Rules. ZBR Rewrite sets procedures for appointing certified water right examiners and govern beneficial use examinations and the filing of beneficial use examination reports.

37-0303-2301, Rules and Minimum Standards for the Construction and Use of Injection Wells. ZBR Rewrite establishes minimum standards and criteria for the construction and abandonment of, and injection of fluid into, Class V deep and shallow injection wells in the state, except Indian lands, along with prohibiting the construction and use of Class I, III, IV, or VI injection wells.

37-0309-2401, Well Construction Standards Rules. For the protection of ground water resources of the state against waste and contamination, this ZBR Rewrite administers minimum standards for the construction of all new wells and the modification and decommissioning of existing wells.

37-0311-2401, Rules for Conjunctive Management of Surface and Ground Water Resources. Targeted change will ensure continuity between statute and rule when clarifying the area having a common ground water supply for the Eastern Snake Plain Aquifer.

IDAPA 39 – IDAHO TRANSPORTATION DEPARTMENT

PO Box 7129, Boise, ID 83707-1129

39-0203-2401, Rules Governing Vehicle Dealer's Principal Place of Business and Claims to the Idaho Consumer Asset Recovery Fund. ZBR Rewrite clarifies terms used in the statutory definition of "principal place of business" and provides for definitions and processes for payment of claims from the Idaho Consumer Asset Recovery Fund.

39-0275-2401, Rules Governing Names on Drivers' Licenses and Identification Cards. Proposed changes align the standardized recording of an individual's name with their verified identity documentation and remove unnecessary and prohibitive language.

39-0341-2401, Rules Governing Traffic Control Devices. Changes articulate portions of the Manual on Uniform Traffic Control Devices that Idaho does not comply with to remain in substantial conformance with required federal code.

39-0360-2401, Rules Governing Outdoor Advertising, Accident Memorials, and Other Official Signs. ZBR Rewrite provides for the control of outdoor advertising signs, structures, or displays along the interstate, primary system of highways, and National Highway System roads of the state.

39-0365-2401, Rules Governing Traffic Minute Entries. ZBR Rewrite establishes the procedures for making traffic minute entries regulating speed zoning, parking, traffic control devices, and the selective exclusion of traffic on the State Highway System.

IDAPA 43 – IDAHO OILSEED COMMISSION

55 SW 5th Ave, Ste 100, Meridian, ID 83642

**43-0101-2401, Rules Governing the Idaho Oilseed Commission.* (*PH) ZBR Rewrite administers the statutory duties of the Idaho Oilseed Commission to include a quarterly tax payment schedule and late payment penalty. Comment by 11/01/2024.

**IDAPA 47 – DIVISION OF VOCATIONAL REHABILITATION
PO Box 83720, Boise, ID 83720-0037**

47-0101-2401, Rules Governing Vocational Rehabilitation Services. As a result of a federal compliance review, language specific to required services related to a primary individual plan and employment maintenance is being removed to comply with federal regulation.

**IDAPA 50 – COMMISSION OF PARDONS AND PAROLE
3056 Elder St, Boise, ID 83705**

50-0101-2401, Rules of the Commission of Pardons and Parole. (Temp & Prop) Rulemaking comports with governing law the time frame in which a person convicted of Assault and Battery and Attempted Strangulation can apply for a pardon.

NOTICES OF ADOPTION OF TEMPORARY RULE ONLY

IDAPA 02 – DEPARTMENT OF AGRICULTURE

02-0609-2404, Rules Governing Invasive Species and Noxious Weeds

IDAPA 08 – STATE BOARD OF EDUCATION

08-0203-2403, Rules Governing Thoroughness

IDAPA 13 – IDAHO DEPARTMENT OF FISH AND GAME

13-0117-2402, Rules Governing Use of Bait for Hunting Big Game Animals

NOTICES OF INTENT TO PROMULGATE RULES – NEGOTIATED RULEMAKING

(Please see the Administrative Bulletin for dates and times of meetings and other participant information)

IDAPA 38 – DEPARTMENT OF ADMINISTRATION

38-0501-2401, Rules of the Division of Purchasing

Please refer to the Idaho Administrative Bulletin **October 2, 2024, Volume 24-10**, for the notices and text of all rulemakings, proclamations, negotiated rulemaking and public hearing information and schedules, executive orders of the Governor, and agency contact information.

Electronic issues of the Idaho Administrative Bulletin can be viewed at www.adminrules.idaho.gov/

Office of the Administrative Rules Coordinator, Division of Financial Management
P.O. Box 83720, Boise, ID 83720-0032
Phone: 208-334-3900; Email: adminrules@dfm.idaho.gov

CUMULATIVE RULEMAKING INDEX OF IDAHO ADMINISTRATIVE RULES

*Office of the Administrative Rules Coordinator
Division of Financial Management
Office of the Governor*

July 1, 1993 – Present

CUMULATIVE RULEMAKING INDEX OF IDAHO ADMINISTRATIVE RULES

This index provides a history of all agency rulemakings beginning with the first Administrative Bulletin in July 1993 to the most recent Bulletin publication. It tracks all rulemaking activities on each chapter of rules by the rulemaking docket numbers and includes negotiated, temporary, proposed, pending and final rules, public hearing notices, vacated rulemaking notices, notice of legislative actions taken on rules, and executive orders of the Governor.

ABRIDGED RULEMAKING INDEX OF IDAHO ADMINISTRATIVE RULES

(Index of Current and Active Rulemakings)

*Office of the Administrative Rules Coordinator
Division of Financial Management*

April 10, 2024 – October 2, 2024

(PLR 2025) – Final Effective Date Is Pending Legislative Review in 2025

(eff. date)L – Denotes Adoption by Legislative Action

(eff. date)T – Temporary Rule Effective Date

SCR # – denotes the number of a Senate Concurrent Resolution (Legislative Action)

HCR # – denotes the number of a House Concurrent Resolution (Legislative Action)

(This Abridged Index includes all active rulemakings.)

IDAPA 02 – IDAHO DEPARTMENT OF AGRICULTURE

02.02.12, Bonded Warehouse Rules

- 02-0212-2401** Notice of Proposed Rulemaking (ZBR Chapter Rewrite), Bulletin Vol. 24-10
- 02-0212-2401** Notice of Intent to Promulgate Rules – Zero-Based Regulation (ZBR) Negotiated Rulemaking, Bulletin Vol. 24-7

02.02.14, Rules for Weights and Measures

- 02-0214-2401** Notice of Proposed Rulemaking, Bulletin Vol. 24-10

02.03.01, Rules Governing Pesticide Management Plans for Ground Water Protection

- 02-0301-2401** Notice of Proposed Rulemaking (ZBR Chapter Rewrite), Bulletin Vol. 24-10
- 02-0301-2401** Notice of Intent to Promulgate Rules – Zero-Based Regulation (ZBR) Negotiated Rulemaking, Bulletin Vol. 24-7

02.03.03, Rules Governing Pesticide and Chemigation Use and Application

- 02-0303-2402** Notice of Temporary and Proposed Rule, Bulletin Vol. 24-7 (eff. 7-1-24)T
- 02-0303-2401** Adoption of Temporary Rule, Bulletin Vol. 24-5 (eff. 4-22-24)T [expires 7-1-24]

02.04.03, Rules Governing Animal Industry

- 02-0403-2401** Notice of Proposed Rulemaking (ZBR Chapter Rewrite), Bulletin Vol. 24-10
- 02-0403-2401** Notice of Intent to Promulgate Rules – Zero-Based Regulation (ZBR) Negotiated Rulemaking, Bulletin Vol. 24-7

02.04.05, Rules Governing Grade A Milk and Manufacture Grade Milk

- 02-0405-2401** Notice of Proposed Rulemaking, Bulletin Vol. 24-10

02.04.15, Rules Governing Beef Cattle Animal Feeding Operations

- 02-0415-2401** Notice of Proposed Rulemaking, Bulletin Vol. 24-10
- 02-0415-2401** Notice of Intent to Promulgate Rules – Negotiated Rulemaking, Bulletin Vol. 24-7

02.04.19, Rules Governing Domestic Cervidae

- 02-0419-2401** Notice of Proposed Rulemaking, Bulletin Vol. 24-10
- 02-0419-2401** Notice of Intent to Promulgate Rules – Negotiated Rulemaking, Bulletin Vol. 24-7

02.05.01, Rules Governing Produce Safety

- 02-0501-2401** Notice of Proposed Rulemaking (ZBR Chapter Rewrite), Bulletin Vol. 24-10
- 02-0501-2401** Notice of Intent to Promulgate Rules – Zero-Based Regulation (ZBR) Negotiated Rulemaking, Bulletin Vol. 24-7

02.06.02, Rules Governing Registrations and Licenses

- 02-0602-2401** Notice of Proposed Rulemaking, Bulletin Vol. 24-10

02.06.09, Rules Governing Invasive Species and Noxious Weeds

- 02-0609-2404** Adoption of Temporary Rule, Bulletin Vol. 24-10 (eff. 9-26-24)T
- 02-0609-2403** Adoption of Temporary Rule, Bulletin Vol. 24-8 (eff. 6-28-24)T
- 02-0609-2402** Notice of Proposed Rulemaking, Bulletin Vol. 24-10
- 02-0609-2402** Notice of Intent to Promulgate Rules – Negotiated Rulemaking, Bulletin Vol. 24-7
- 02-0609-2401** Adoption of Temporary Rule, Bulletin Vol. 24-4 (eff. *sine die* 2024)T

02.06.33, Organic Food Products Rules

- 02-0633-2401** Notice of Proposed Rulemaking, Bulletin Vol. 24-10

02.08.01, Sheep and Goat Rules of the Idaho Sheep and Goat Health Board

- 02-0801-2401** Notice of Proposed Rulemaking (ZBR Chapter Rewrite), Bulletin Vol. 24-10
- 02-0801-2401** Notice of Intent to Promulgate Rules – Zero-Based Regulation (ZBR) Negotiated Rulemaking, Bulletin Vol. 24-6

IDAPA 04 – OFFICE OF THE ATTORNEY GENERAL

04.11.01, Idaho Rules of Administrative Procedure of the Attorney General

44-0000-2400 Notice of Omnibus Rulemaking – Revocation of Final Rule – Certain provisions rendered null and void pertaining to IDAPA chapter 04.11.01 – Bulletin Vol. 24-7

**IDAPA 08 – IDAHO STATE BOARD OF EDUCATION
AND STATE DEPARTMENT OF EDUCATION**

08.01.11, Registration of Postsecondary Educational Institutions and Proprietary Schools

08-0111-2401 Notice of Temporary and Proposed Rule, Bulletin Vol. 24-7 (eff. 7-1-24)T

08.01.13, Rules Governing the Opportunity Scholarship Program

08-0113-2401 Notice of Proposed Rulemaking, Bulletin Vol. 24-10

08-0113-2401 Notice of Intent to Promulgate Rules – Negotiated Rulemaking, Bulletin Vol. 24-6

08.01.15, Rules Governing the Firearms Safety Grant Program

08-0115-2401 Notice of Intent to Promulgate Rules (New Chapter) – Negotiated Rulemaking, Bulletin Vol. 24-6

08.02.01, Rules Governing Administration

08-0201-2401 Notice of Temporary and Proposed Rule, Bulletin Vol. 24-7 (eff. 7-1-24)T

08.02.02, Rules Governing Uniformity

08-0202-2401 Notice of Proposed Rulemaking, Bulletin Vol. 24-10

08-0202-2401 Notice of Intent to Promulgate Rules – Negotiated Rulemaking, Bulletin Vol. 24-6

08.02.03, Rules Governing Thoroughness

08-0203-2403 Adoption of Temporary Rule, Bulletin Vol. 24-10 (eff. 8-21-24)T

08-0203-2402 Adoption of Temporary Rule, Bulletin Vol. 24-7 (eff. 7-1-24)T

08-0203-2401 Notice of Proposed Rulemaking, Bulletin Vol. 24-10

08-0203-2401 Notice of Intent to Promulgate Rules – Negotiated Rulemaking, Bulletin Vol. 24-6

08.02.04, Rules Governing Public Charter Schools

08-0204-2400 Notice of Revocation of Final Rule, Bulletin Vol. 24-3

08.04.01, Rules of the Idaho Digital Learning Academy

08-0401-2401 Notice of Proposed Rulemaking, Bulletin Vol. 24-10

08-0401-2401 Notice of Intent to Promulgate Rules – Negotiated Rulemaking, Bulletin Vol. 24-6

IDAPA 09 – IDAHO DEPARTMENT OF LABOR

09.01.01, Rules of Administrative Procedure of the Department of Labor

09-0101-2401 Notice of Proposed Rulemaking (ZBR Chapter Rewrite), Bulletin Vol. 24-10

09-0101-2401 Notice of Intent to Promulgate Rules – Zero-Based Regulation (ZBR) Negotiated Rulemaking, Bulletin Vol. 24-7

09.01.08, Rules on Disclosure of Employment Security Information

09-0108-2401 Notice of Intent to Promulgate Rules – Zero-Based Regulation (ZBR) Negotiated Rulemaking, Bulletin Vol. 24-8

09.01.30, Unemployment Insurance Benefits Administration Rules

09-0130-2401 Notice of Proposed Rulemaking (ZBR Chapter Rewrite), Bulletin Vol. 24-10

09-0130-2401 Notice of Intent to Promulgate Rules – Zero-Based Regulation (ZBR) Negotiated Rulemaking, Bulletin Vol. 24-7

09.01.35, Unemployment Insurance Tax Administration Rules

09-0135-2401 Notice of Proposed Rulemaking (ZBR Chapter Rewrite), Bulletin Vol. 24-10

09-0135-2401 Notice of Intent to Promulgate Rules – Zero-Based Regulation (ZBR) Negotiated Rulemaking, Bulletin Vol. 24-7

09.05.03, Rules for Determining Bargaining Representatives

09-0503-2401 Notice of Intent to Promulgate Rules – Zero-Based Regulation (ZBR) Negotiated Rulemaking, Bulletin Vol. 24-8

IDAPA 11 – IDAHO STATE POLICE

Idaho State Brand Board

11.02.01, Rules of the Idaho State Brand Board

11-0201-2401 Notice of Intent to Promulgate Rules – Negotiated Rulemaking, Bulletin Vol. 24-7 (terminated by agency)

Idaho State Police Forensic Services

11.03.01, Rules Governing Alcohol Testing

11-0301-2401 Notice of Proposed Rulemaking (ZBR Chapter Rewrite), Bulletin Vol. 24-10

11-0301-2401 Notice of Intent to Promulgate Rules – Zero-Based Regulation (ZBR) Negotiated Rulemaking, Bulletin Vol. 24-8

Idaho State Racing Commission

11.04.01, Rules Governing the Idaho State Racing Commission

44-0000-2400 Notice of Omnibus Rulemaking – Revocation of Final Rule – Certain provisions rendered null and void pertaining to IDAPA 11.04.01 – Bulletin Vol. 24-7

Alcohol Beverage Control Bureau

11.05.01, Rules Governing Alcohol Beverage Control

11-0501-2403 Notice of Proposed Rulemaking (ZBR Chapter Rewrite), Bulletin Vol. 24-9

11-0501-2403 Notice of Intent to Promulgate Rules – Zero-Based Regulation (ZBR) Negotiated Rulemaking, Bulletin Vol. 24-7

11-0501-2402 Adoption of Temporary Rule, Bulletin Vol. 24-7 (eff. 7-1-24)T

11-0501-2401 Adoption of Temporary Rule, Bulletin Vol. 24-4 (eff. *sine die* 2024)T [*expires 7-1-24*]

Peace Officer Standards and Training (POST) Council

11.11.01, Rules of the Idaho Peace Officer Standards and Training Council

11-1101-2401 Adoption of Pending Rule, Bulletin Vol. 24-10 (PLR 2025)

11-1101-2401 Notice of Temporary and Proposed Rule, Bulletin Vol. 24-7 (eff. 6-7-24)T

Idaho State Police Commercial Vehicle Safety

11.13.01, The Motor Carrier Rules

11-1301-2401 Notice of Temporary and Proposed Rule, Bulletin Vol. 24-8 (eff. 7-1-24)T

IDAPA 13 – IDAHO FISH AND GAME COMMISSION

Establishing Seasons and Limits for Hunting, Fishing, and Trapping in Idaho

13-0000-2400P6 Notice of Adopted / Amended Proclamations for Calendar Year 2024, Bulletin Vol. 24-9

13-0000-2400P5 Notice of Adopted / Amended Proclamations for Calendar Year 2024, Bulletin Vol. 24-8

13-0000-2400P4 Notice of Adopted / Amended Proclamations for Calendar Year 2024, Bulletin Vol. 24-7

13-0000-2400P3 Notice of Adopted / Amended Proclamations for Calendar Year 2024, Bulletin Vol. 24-6

13-0000-2400P2 Notice of Adopted / Amended Proclamations for Calendar Year 2024, Bulletin Vol. 24-5

13-0000-2400P1 Notice of Adoption of Proclamation for Calendar Year 2024, Bulletin Vol. 24-2

13.01.02, Rules Governing Mandatory Education, Mentored Hunting, and Shooting Ranges

13-0102-2401 Notice of Temporary and Proposed Rule, Bulletin Vol. 24-10 (eff. 1-1-25)T

13.01.04, Rules Governing Licensing

13-0104-2401 Notice of Intent to Promulgate Rules – Zero-Based Regulation (ZBR) Negotiated Rulemaking, Bulletin Vol. 24-5

13.01.07, Rules Governing Taking of Wildlife

13-0107-2401 Notice of Proposed Rulemaking, Bulletin Vol. 24-10

13.01.08, Rules Governing Taking of Big Game Animals

13-0108-2401 Notice of Intent to Promulgate Rules – Zero-Based Regulation (ZBR) Negotiated Rulemaking, Bulletin Vol. 24-5

13.01.11, Rules Governing Fish

- 13-0111-2401 Notice of Proposed Rulemaking, Bulletin Vol. 24-10
- 13-0111-2401 Notice of Intent to Promulgate Rules – Negotiated Rulemaking, Bulletin Vol. 24-7

13.01.16, Trapping of Wildlife and Taking of Furbearing Animals

- 13-0116-2401 Notice of Intent to Promulgate Rules – Zero-Based Regulation (ZBR) Negotiated Rulemaking, Bulletin Vol. 24-5

13.01.17, Rules Governing Use of Bait for Hunting Big Game Animals

- 13-0117-2402 Adoption of Temporary Rule, Bulletin Vol. 24-10 (eff. 9-1-24)T

- 13-0117-2401 Notice of Intent to Promulgate Rules – Zero-Based Regulation (ZBR) Negotiated Rulemaking, Bulletin Vol. 24-5

IDAPA 15 – OFFICE OF THE GOVERNOR

Executive Orders of the Governor

- Executive Order No. 2024-08 Defending Women’s Sports Act, Bulletin Vol. 24-9
- Executive Order No. 2024-07 Only Citizens Will Vote Act, Bulletin Vol. 24-8
- Executive Order No. 2024-06 Protecting Idaho Water Sovereignty Act, Bulletin Vol. 24-7
- Executive Order No. 2024-05 Promoting Families and Protecting Children, Bulletin Vol. 24-7
- Executive Order No. 2024-04 Operation Esto Perpetua, Bulletin Vol. 24-5
- Executive Order No. 2024-03 Continuing the Juvenile Justice Commission, Bulletin Vol. 24-5
- Executive Order No. 2024-02 Continuing the Workforce Development Council, Bulletin Vol. 24-5
- Executive Order No. 2024-01 Continuing the Idaho Behavioral Health Council, Bulletin Vol. 24-5

Executive Order Retrospective Spanning Years 1938-1995, Bulletin Vol. 24-3SE

State of the State and Budget Addresses of the Governor

State of the State and Budget Addresses Retrospective Spanning Years 1890-2024, Bulletin Vol. 24-4SE

Idaho Commission for the Blind and Visually Impaired

15.02.30, Business Enterprise Program

- 15-0230-2401 Notice of Intent to Promulgate Rules – Zero-Based Regulation (ZBR) Negotiated Rulemaking, Bulletin Vol. 24-9

Division of Human Resources and Personnel Commission

15.04.01, Rules of the Division of Human Resources and Idaho Personnel Commission

- 44-0000-2401 Notice of Omnibus Rulemaking – Revocation of Final Rule – Certain provisions rendered null and void pertaining to IDAPA 15.04.01 – Bulletin Vol. 24-8

Idaho Military Division

15.06.05, Hazardous Substance Response Rules

- 15-0605-2401 Notice of Intent to Promulgate Rules – Zero-Based Regulation (ZBR) Negotiated Rulemaking, Bulletin Vol. 24-8

IDAPA 16 – DEPARTMENT OF HEALTH AND WELFARE

16.01.01, Emergency Medical Services

- 16-0101-2401 Notice of Proposed Rulemaking (New Chapter), Bulletin Vol. 24-9

16.01.02, Emergency Medical Services (EMS) – Rule Definitions

- 16-0102-2401 Notice of Proposed Rulemaking (Chapter Repeal), Bulletin Vol. 24-9

16.01.03, Emergency Medical Services (EMS) -- Agency Licensing Requirements

- 16-0103-2401 Notice of Proposed Rulemaking (Chapter Repeal), Bulletin Vol. 24-9

16.01.05, Emergency Medical Services (EMS) -- Education, Instructor, & Examination Requirements

- 16-0105-2401 Notice of Proposed Rulemaking (Chapter Repeal), Bulletin Vol. 24-9

16.01.07, Emergency Medical Services (EMS) – Personnel Licensing Requirements

- 16-0107-2401 Notice of Proposed Rulemaking (ZBR Chapter Repeal), Bulletin Vol. 24-9
- 16-0107-2401 Notice of Intent to Promulgate Rules – Zero-Based Regulation (ZBR) Negotiated Rulemaking, Bulletin Vol. 24-4

16.01.12, Emergency Medical Services (EMS) -- Complaints, Investigations, and Disciplinary Actions

- 16-0112-2401 Notice of Proposed Rulemaking (Chapter Repeal), Bulletin Vol. 24-9

16.02.01, Idaho Time Sensitive Emergency System Council

- 16-0201-2401 Notice of Proposed Rulemaking (Chapter Repeal), Bulletin Vol. 24-9

16.02.02, Idaho Emergency Medical Services (EMS) Physician Commission

- 16-0202-2401 Notice of Proposed Rulemaking (Chapter Repeal), Bulletin Vol. 24-9

16.02.12, Newborn Screening

- 16-0212-2401 Notice of Proposed Rulemaking (ZBR Chapter Rewrite), Bulletin Vol. 24-9

16.02.13, State of Idaho Drinking Water Laboratory Certification Program

- 16-0213-2401* Notice of Public Hearing and Extension of Written Comment Period, Bulletin Vol. 24-10
- 16-0213-2401* Notice of Proposed Rulemaking (ZBR Chapter Rewrite, Fee Rule), Bulletin Vol. 24-9
- *Changes chapter name from: "State of Idaho Drinking Water Laboratory Certification Program"
- 16-0213-2401 Notice of Intent to Promulgate Rules – Zero-Based Regulation (ZBR) Negotiated Rulemaking, Bulletin Vol. 24-5

16.03.09, Medicaid Basic Plan Benefits

- 16-0309-2401 Notice of Proposed Rulemaking (ZBR Chapter Rewrite), Bulletin Vol. 24-9
- 16-0309-2401 Notice of Intent to Promulgate Rules – Zero-Based Regulation (ZBR) Negotiated Rulemaking, Bulletin Vol. 24-5

16.03.11, Intermediate Care Facilities for People with Intellectual Disabilities (ICFs/IID)

- 16-0311-2401 Notice of Intent to Promulgate Rules – Zero-Based Regulation (ZBR) Negotiated Rulemaking, Bulletin Vol. 24-5

16.03.13, Consumer-Directed Services

- 16-0313-2401 Notice of Proposed Rulemaking (ZBR Chapter Rewrite), Bulletin Vol. 24-9
- 16-0313-2401 Notice of Intent to Promulgate Rules – Zero-Based Regulation (ZBR) Negotiated Rulemaking, Bulletin Vol. 24-5

16.03.14, Hospitals

- 16-0314-2401 Notice of Proposed Rulemaking (ZBR Chapter Repeal), Bulletin Vol. 24-9
- 16-0314-2401 Notice of Intent to Promulgate Rules – Zero-Based Regulation (ZBR) Negotiated Rulemaking, Bulletin Vol. 24-5

- 16-0314-2301 OARC Corrected Omnibus Notice of Legislative Action – Extension of Temporary Rule, Bulletin Vol. 24-9 (eff. 7-1-24)
- 16-0314-2301 OARC Omnibus Notice of Legislative Action – Extension of Temporary Rule, Bulletin Vol. 24-8 (eff. 11-14-23)T
- 16-0314-2301 Adoption of Temporary Rule, Bulletin Vol. 23-12 (eff. 11-14-23)T

16.04.07, Fees for State Hospital North and State Hospital South

- 16-0407-2401 Notice of Proposed Rulemaking (Chapter Repeal), Bulletin Vol. 24-9

16.04.18, Children’s Agencies and Residential Licensing

- 16-0418-2401 Adoption of Pending Rule, Bulletin Vol. 24-9 (PLR 2025)
- 16-0418-2401 Notice of Temporary and Proposed Rule, Bulletin Vol. 24-7 (eff. 7-1-24)T

16.05.01, Use and Disclosure of Department Records

- 16-0501-2401 Notice of Temporary and Proposed Rule, Bulletin Vol. 24-9 (eff. 8-6-24)T

16.05.03, Contested Cases Proceedings and Declaratory Rulings

- 44-0000-2400 Notice of Omnibus Rulemaking – Revocation of Final Rule – Certain provisions rendered null and void pertaining to IDAPA 16.05.03 – Bulletin Vol. 24-7

(MOVED AND REDESIGNATED) 16.05.04, Domestic Violence Council Grants

- 16-0504-2400 IDAPA 16.05 – IDAHO COUNCIL ON DOMESTIC VIOLENCE AND VICTIM ASSISTANCE – Notice of Assignment of New IDAPA Designation Number – Redesignated from IDAPA 16, Title 05, Chapter 04 to IDAPA 63, Title 05, Chapter 04 – Bulletin Vol. 24-6 (eff. 7-1-24)

16.06.01, Child and Family Services

- 16-0601-2404 Adoption of Temporary Rule, Bulletin Vol. 24-9 (eff. 8-6-24)T

- 16-0601-2403** Adoption of Temporary Rule, Bulletin Vol. 24-7 (eff. 6-5-24)T
- 16-0601-2402** Notice of Vacation of Proposed Rulemaking, Bulletin Vol. 24-9
- 16-0601-2402** Notice of Temporary and Proposed Rule, Bulletin Vol. 24-6 (eff. 4-17-24)T
- 16-0601-2401** Notice of Proposed Rulemaking (ZBR Chapter Rewrite), Bulletin Vol. 24-9
- 16-0601-2401** Notice of Intent to Promulgate Rules – Zero-Based Regulation (ZBR) Negotiated Rulemaking, Bulletin Vol. 24-4

16.06.02, Foster Care Licensing

- 16-0602-2403** Adoption of Temporary Rule, Bulletin Vol. 24-9 (eff. 8-15-24)T
- 16-0602-2402** Adoption of Pending Rule (Chapter Rewrite), Bulletin Vol. 24-9 (PLR 2025)
- 16-0602-2402** Notice of Temporary and Proposed Rule (Chapter Rewrite), Bulletin Vol. 24-7 (eff. 7-1-24)T
- 16-0602-2401** Adoption of Pending Rule (Chapter Repeal), Bulletin Vol. 24-9 (PLR 2025)
- 16-0602-2401** Notice of Temporary and Proposed Rule (Chapter Repeal), Bulletin Vol. 24-7 (eff. 7-1-24)T

16.06.03, Daycare Licensing

- 16-0603-2401** Adoption of Temporary Rule, Bulletin Vol. 24-7 (eff. 7-1-24)T

16.06.05, Alleged Medical Neglect of Handicapped Infants

- 16-0605-2401** Notice of Proposed Rulemaking (Chapter Repeal), Bulletin Vol. 24-9

16.07.37, Children's Mental Health Services

- 16-0737-2401** Notice of Proposed Rulemaking (ZBR Chapter Rewrite), Bulletin Vol. 24-9
- 16-0737-2401** (Second) Notice of Intent to Promulgate Rules – Zero-Based Regulation (ZBR) Negotiated Rulemaking, Bulletin Vol. 24-3
- 16-0737-2401** Notice of Intent to Promulgate Rules – Zero-Based Regulation (ZBR) Negotiated Rulemaking, Bulletin Vol. 24-2

IDAPA 17 – INDUSTRIAL COMMISSION

17.01.01, Administrative Rules Under the Worker's Compensation Law

- 17-0101-2401** Notice of Proposed Rulemaking (ZBR Chapter Rewrite), Bulletin Vol. 24-10
- 17-0101-2301** (Second) Notice of Intent to Promulgate Rules – Zero-Based Regulation (ZBR) Negotiated Rulemaking, Bulletin Vol. 24-5
- 17-0101-2301** Notice of Intent to Promulgate Rules – Zero-Based Regulation (ZBR) Negotiated Rulemaking, Bulletin Vol. 23-11

IDAPA 18 – DEPARTMENT OF INSURANCE

- 18-ZBRR-2401** *Rules of the Idaho Department of Insurance* – Omnibus Notice of Intent to Promulgate Rules – Zero-Based Regulation (ZBR) Negotiated Rulemaking – Negotiates Title 01, Chapter 01; Title 03, Chapters 02-04; Title 04, Chapter 03; Title 05, Chapter 01; Title 06, Chapter 06; and Title 07, Chapters 04, 05 – Bulletin Vol. 24-7

18.01.01, Rule to Implement the Privacy of Consumer Financial Information

- 18-0101-2401** Notice of Proposed Rulemaking (ZBR Chapter Rewrite), Bulletin Vol. 24-9
- 18-ZBRR-2401** *Rules of the Idaho Department of Insurance* – Omnibus Notice of Intent to Promulgate Rules – Zero-Based Regulation (ZBR) Negotiated Rulemaking – Negotiates Title 01, Chapter 01 – Bulletin Vol. 24-7

18.03.02, Life Settlements

- 18-0302-2401** Notice of Proposed Rulemaking (ZBR Chapter Rewrite), Bulletin Vol. 24-9
- 18-ZBRR-2401** *Rules of the Idaho Department of Insurance* – Omnibus Notice of Intent to Promulgate Rules – Zero-Based Regulation (ZBR) Negotiated Rulemaking – Negotiates Title 03, Chapter 02 – Bulletin Vol. 24-7

18.03.03, Variable Contracts

- 18-ZBRR-2401** *Rules of the Idaho Department of Insurance* – Omnibus Notice of Intent to Promulgate Rules – Zero-Based Regulation (ZBR) Negotiated Rulemaking – Negotiates Title 03, Chapter 03 – Bulletin Vol. 24-7

18.03.04, Replacement of Life Insurance and Annuities

- 18-ZBRR-2401** *Rules of the Idaho Department of Insurance* – Omnibus Notice of Intent to Promulgate Rules – Zero-Based Regulation (ZBR) Negotiated Rulemaking – Negotiates Title 03, Chapter 04 – Bulletin Vol. 24-7

18.04.03, Advertisement of Disability (Accident and Sickness) Insurance

18-ZBRR-2401 *Rules of the Idaho Department of Insurance* – Omnibus Notice of Intent to Promulgate Rules – Zero-Based Regulation (ZBR) Negotiated Rulemaking – Negotiates Title 04, Chapter 03 – Bulletin Vol. 24-7

18.04.15, Rules Governing Short-Term Health Insurance Coverage

18-0415-2401 Notice of Intent to Promulgate Rules – Negotiated Rulemaking, Bulletin Vol. 24-7

18.05.01, Rules for Title Insurance Regulation

18-0501-2401 Notice of Proposed Rulemaking (ZBR Chapter Rewrite), Bulletin Vol. 24-9

18-ZBRR-2401 *Rules of the Idaho Department of Insurance* – Omnibus Notice of Intent to Promulgate Rules – Zero-Based Regulation (ZBR) Negotiated Rulemaking – Negotiates Title 05, Chapter 01 – Bulletin Vol. 24-7

18.06.06, Surplus Lines Rules

18-0606-2401 Notice of Proposed Rulemaking (ZBR Chapter Rewrite), Bulletin Vol. 24-9

18-ZBRR-2401 *Rules of the Idaho Department of Insurance* – Omnibus Notice of Intent to Promulgate Rules – Zero-Based Regulation (ZBR) Negotiated Rulemaking – Negotiates Title 06, Chapter 06 – Bulletin Vol. 24-7

18.07.04, Annual Financial Reporting

18-ZBRR-2401 *Rules of the Idaho Department of Insurance* – Omnibus Notice of Intent to Promulgate Rules – Zero-Based Regulation (ZBR) Negotiated Rulemaking – Negotiates Title 07, Chapter 04 – Bulletin Vol. 24-7

18.07.05, Director's Authority for Companies Deemed to be in Hazardous Financial Condition

18-ZBRR-2401 *Rules of the Idaho Department of Insurance* – Omnibus Notice of Intent to Promulgate Rules – Zero-Based Regulation (ZBR) Negotiated Rulemaking – Negotiates Title 07, Chapter 05 – Bulletin Vol. 24-7

18.08.01, Adoption of the International Fire Code

18-0801-2401 Notice of Proposed Rulemaking, Bulletin Vol. 24-9

18-0801-2401 Notice of Intent to Promulgate Rules – Negotiated Rulemaking, Bulletin Vol. 24-7

IDAPA 20 – DEPARTMENT OF LANDS

20.01.01, Rules of Practice and Procedure Before the State Board of Land Commissioners

44-0000-2400 *Notice of Omnibus Rulemaking – Revocation of Final Rule – Certain provisions rendered null and void pertaining to IDAPA 20.01.01* – Bulletin Vol. 24-7

20.03.02, Rules Governing Mined Land Reclamation

20-0302-2401 Notice of Intent to Promulgate Rules – Zero-Based Regulation (ZBR) Negotiated Rulemaking, Bulletin Vol. 24-4

20.03.04, Rules Governing the Regulation of Beds, Waters, and Airspace Over Navigable Lakes in the State of Idaho

20-0304-2401 Notice of Intent to Promulgate Rules – Zero-Based Regulation (ZBR) Negotiated Rulemaking, Bulletin Vol. 24-4

20.03.13, Administration of Cottage Site Leases on State Lands

20-0313-2401 Adoption of Pending Rule (ZBR Chapter Rewrite), Bulletin Vol. 24-10 (PLR 2025)

20-0313-2401 Notice of Proposed Rulemaking (ZBR Chapter Rewrite), Bulletin Vol. 24-7

20-0313-2401 Notice of Intent to Promulgate Rules – Zero-Based Regulation (ZBR) Negotiated Rulemaking, Bulletin Vol. 24-3

20.03.14, Rules Governing Grazing, Farming, and Conservation Leases

20-0314-2401* Adoption of Pending Rule (ZBR Chapter Rewrite), Bulletin Vol. 24-10 (PLR 2025)

**Changes chapter name from: "Rules Governing Grazing, Farming, Conservation, Noncommercial Recreation, and Communication Site Leases"*

20-0314-2401* Notice of Proposed Rulemaking (ZBR Chapter Rewrite), Bulletin Vol. 24-7

20-0314-2401 Notice of Intent to Promulgate Rules – Zero-Based Regulation (ZBR) Negotiated Rulemaking, Bulletin Vol. 24-3

20.03.15, Rules Governing Geothermal Leasing on Idaho State Lands

20-0315-2401 Adoption of Pending Rule (ZBR Chapter Rewrite, Fee Rule), Bulletin Vol. 24-10 (PLR 2025)

20-0315-2401 Notice of Proposed Rulemaking (ZBR Chapter Rewrite, Fee Rule), Bulletin Vol. 24-7

20-0315-2401 Notice of Intent to Promulgate Rules – Zero-Based Regulation (ZBR) Negotiated Rulemaking, Bulletin Vol. 24-3

20.03.16, Rules Governing Oil and Gas Leasing on Idaho State Lands

20-0316-2401 Adoption of Pending Rule (ZBR Chapter Rewrite, Fee Rule), Bulletin Vol. 24-10 (PLR 2025)

20-0316-2401 Notice of Proposed Rulemaking (ZBR Chapter Rewrite, Fee Rule), Bulletin Vol. 24-7

20-0316-2401 Notice of Intent to Promulgate Rules – Zero-Based Regulation (ZBR) Negotiated Rulemaking, Bulletin Vol. 24-3

20.04.01, Rules Pertaining to Forest Fire Protection

- 20-0401-2301 Notice of Proposed Rulemaking (ZBR Chapter Rewrite), Bulletin Vol. 24-7
- 20-0401-2301 Notice of Intent to Promulgate Rules – Zero-Based Regulation (ZBR) Negotiated Rulemaking, Bulletin Vol. 23-10

20.04.02, Rules Pertaining to the Idaho Forestry Act and Fire Hazard Reduction Laws

- 20-0402-2301 Notice of Proposed Rulemaking (ZBR Chapter Rewrite), Bulletin Vol. 24-7
- 20-0402-2301 Notice of Intent to Promulgate Rules – Zero-Based Regulation (ZBR) Negotiated Rulemaking, Bulletin Vol. 23-10

20.07.02, Rules Governing Conservation of Oil and Natural Gas in the State of Idaho

- 20-0702-2401 Notice of Proposed Rulemaking (ZBR Chapter Rewrite), Bulletin Vol. 24-8
- 20-0702-2401 Notice of Intent to Promulgate Rules – Zero-Based Regulation (ZBR) Negotiated Rulemaking, Bulletin Vol. 24-4

IDAPA 21 – DIVISION OF VETERANS SERVICES

21.01.01, Rules Governing Admission, Residency, and Maintenance Charges in Idaho State Veterans Homes and Division of Veterans Services Administrative Procedure

- 44-0000-2400 Notice of Omnibus Rulemaking – Revocation of Final Rule – Certain provisions rendered null and void pertaining to IDAPA 21.01.01 – Bulletin Vol. 24-7

21.01.04, Rules Governing Idaho State Veterans Cemeteries

- 21-0104-2402 Notice of Proposed Rulemaking (Fee Rule), Bulletin Vol. 24-6
- 21-0104-2401 Adoption of Temporary Rule (Fee Rule), Bulletin Vol. 24-5 (eff. 4-10-24)T

IDAPA 24 – DIVISION OF OCCUPATIONAL AND PROFESSIONAL LICENSES

- 24-ZBRR-2401 *Rules of the Division of Occupational and Professional Licenses* – Omnibus Notice of Intent to Promulgate Rules – Zero-Based Regulation (ZBR) Negotiated Rulemaking – Negotiates Title 02, Chapter 01; Title 03, Chapter 01; Title 08, Chapter 01; Title 09, Chapter 01; Title 19, Chapter 01; Title 24, Chapter 01; Title 29, Chapter 01; Title 33, Chapters 01-07; and Title 36, Chapter 01 – Bulletin Vol. 24-4

24.02.01, Rules of the State Athletic Commission

- 24-0201-2402 Notice of Proposed Rulemaking (ZBR New Chapter), Bulletin Vol. 24-8
- 24-ZBRR-2401 *Rules of the Division of Occupational and Professional Licenses* – Omnibus Notice of Intent to Promulgate Rules – Zero-Based Regulation (ZBR) Negotiated Rulemaking – Negotiates Title 02, Chapter 01 – Bulletin Vol. 24-4
- 24-0201-2401 Adoption of Temporary Rule (New Chapter, Fee Rule), Bulletin Vol. 24-6 (eff. 6-1-24)T

24.03.01, Rules of the State Board of Chiropractic Physicians

- 24-0301-2401 Adoption of Pending Rule (ZBR Chapter Rewrite), Bulletin Vol. 24-10 (PLR 2025)
- 24-0301-2401 Notice of Proposed Rulemaking (ZBR Chapter Rewrite), Bulletin Vol. 24-7
- 24-ZBRR-2401 *Rules of the Division of Occupational and Professional Licenses* – Omnibus Notice of Intent to Promulgate Rules – Zero-Based Regulation (ZBR) Negotiated Rulemaking – Negotiates Title 03, Chapter 01 – Bulletin Vol. 24-4

24.04.01, Rules of the Board of Registration for Professionals Geologists

- 24-0401-2401 Notice of Proposed Rulemaking (ZBR Chapter Rewrite, Fee Rule), Bulletin Vol. 24-10
- 24-0401-2401 Notice of Intent to Promulgate Rules – Zero-Based Regulation (ZBR) Negotiated Rulemaking, Bulletin Vol. 24-6

24.08.01, Rules of the State Board of Morticians

- 24-0801-2401 Notice of Proposed Rulemaking (ZBR Chapter Rewrite, Fee Rule), Bulletin Vol. 24-9
- 24-ZBRR-2401 *Rules of the Division of Occupational and Professional Licenses* – Omnibus Notice of Intent to Promulgate Rules – Zero-Based Regulation (ZBR) Negotiated Rulemaking – Negotiates Title 08, Chapter 01 – Bulletin Vol. 24-4

24.09.01, Rules of the Board of Examiners of Nursing Home Administrators

- 24-0901-2401 Adoption of Pending Rule (ZBR Chapter Rewrite), Bulletin Vol. 24-10 (PLR 2025)
- 24-0901-2401 Notice of Proposed Rulemaking (ZBR Chapter Rewrite), Bulletin Vol. 24-7
- 24-ZBRR-2401 *Rules of the Division of Occupational and Professional Licenses* – Omnibus Notice of Intent to Promulgate Rules – Zero-Based Regulation (ZBR) Negotiated Rulemaking – Negotiates Title 09, Chapter 01 – Bulletin Vol. 24-4

24.19.01, Rules of the Board of Examiners of Residential Care Facility Administrators

- 24-1901-2401 Adoption of Pending Rule (ZBR Chapter Rewrite, Fee Rule), Bulletin Vol. 24-10 (PLR 2025)

- 24-1901-2401** Notice of Proposed Rulemaking (ZBR Chapter Rewrite, Fee Rule), Bulletin Vol. 24-7
24-ZBRR-2401 *Rules of the Division of Occupational and Professional Licenses* – Omnibus Notice of Intent to Promulgate Rules – Zero-Based Regulation (ZBR) Negotiated Rulemaking – Negotiates Title 19, Chapter 01 – Bulletin Vol. 24-4

24.21.01, Rules of the Idaho State Contractors Board

- 24-2101-2401** Notice of Proposed Rulemaking (ZBR Chapter Rewrite), Bulletin Vol. 24-10
24-2101-2401 Notice of Intent to Promulgate Rules – Zero-Based Regulation (ZBR) Negotiated Rulemaking, Bulletin Vol. 24-6

24.22.01, Rules of the Idaho State Liquefied Petroleum Gas Safety Board

- 24-2201-2401** Notice of Proposed Rulemaking (ZBR Chapter Rewrite), Bulletin Vol. 24-9
24-2201-2401 Notice of Intent to Promulgate Rules – Zero-Based Regulation (ZBR) Negotiated Rulemaking, Bulletin Vol. 24-7

24.24.01, Rules of the Genetic Counselors Licensing Board

- 24-2401-2401** Adoption of Pending Rule (ZBR Chapter Rewrite), Bulletin Vol. 24-10 (PLR 2025)
24-2401-2401 Notice of Proposed Rulemaking (ZBR Chapter Rewrite), Bulletin Vol. 24-7
24-ZBRR-2401 *Rules of the Division of Occupational and Professional Licenses* – Omnibus Notice of Intent to Promulgate Rules – Zero-Based Regulation (ZBR) Negotiated Rulemaking – Negotiates Title 24, Chapter 01 – Bulletin Vol. 24-4

24.29.01, Rules of Procedure of the Idaho Certified Shorthand Reporters Board

- 24-2901-2401** Notice of Proposed Rulemaking (ZBR Chapter Rewrite), Bulletin Vol. 24-8
24-ZBRR-2401 *Rules of the Division of Occupational and Professional Licenses* – Omnibus Notice of Intent to Promulgate Rules – Zero-Based Regulation (ZBR) Negotiated Rulemaking – Negotiates Title 29, Chapter 01 – Bulletin Vol. 24-4

24.30.01, Idaho Accountancy Rules

- 24-3001-2401** Notice of Proposed Rulemaking, Bulletin Vol. 24-9
24-3001-2401 Notice of Intent to Promulgate Rules – Negotiated Rulemaking, Bulletin Vol. 24-6

24.32.01, Rules of the Idaho Board of Licensure of Professional Engineers and Professional Land Surveyors

- 24-3201-2401** Notice of Proposed Rulemaking (ZBR Chapter Rewrite), Bulletin Vol. 24-9
24-3201-2401 Notice of Intent to Promulgate Rules – Zero-Based Regulation (ZBR) Negotiated Rulemaking, Bulletin Vol. 24-6

24.33.01, Rules of the Board of Medicine for the Practice of Medicine and Osteopathic Medicine in Idaho

- 24-3301-2401*** Adoption of Pending Rule (ZBR Chapter Rewrite, Fee Rule), Bulletin Vol. 24-10 (PLR 2025)
**Changes chapter name from: “Rules of the Board of Medicine for the Licensure to Practice Medicine and Osteopathic Medicine in Idaho”*
24-3301-2401* Notice of Proposed Rulemaking (ZBR Chapter Rewrite, Fee Rule), Bulletin Vol. 24-7
24-ZBRR-2401 *Rules of the Division of Occupational and Professional Licenses* – Omnibus Notice of Intent to Promulgate Rules – Zero-Based Regulation (ZBR) Negotiated Rulemaking – Negotiates Title 33, Chapter 01 – Bulletin Vol. 24-4

24.33.02, Rules for the Licensure of Physician Assistants

- 24-3302-2401** Adoption of Pending Rule (ZBR Chapter Rewrite), Bulletin Vol. 24-10 (PLR 2025)
24-3302-2401 Notice of Proposed Rulemaking (ZBR Chapter Rewrite), Bulletin Vol. 24-7
24-ZBRR-2401 *Rules of the Division of Occupational and Professional Licenses* – Omnibus Notice of Intent to Promulgate Rules – Zero-Based Regulation (ZBR) Negotiated Rulemaking – Negotiates Title 33, Chapter 02 – Bulletin Vol. 24-4

24.33.03, General Provisions of the Board of Medicine

- 24-3303-2401** Adoption of Pending Rule (ZBR Chapter Repeal), Bulletin Vol. 24-10 (PLR 2025)
24-3303-2401 Notice of Proposed Rulemaking (ZBR Chapter Repeal), Bulletin Vol. 24-7
24-ZBRR-2401 *Rules of the Division of Occupational and Professional Licenses* – Omnibus Notice of Intent to Promulgate Rules – Zero-Based Regulation (ZBR) Negotiated Rulemaking – Negotiates Title 33, Chapter 03 – Bulletin Vol. 24-4

24.33.04, Rules for the Licensure of Naturopathic Medical Doctors

- 24-3304-2401** Adoption of Pending Rule (ZBR Chapter Rewrite), Bulletin Vol. 24-10 (PLR 2025)
24-3304-2401 Notice of Proposed Rulemaking (ZBR Chapter Rewrite), Bulletin Vol. 24-7
24-ZBRR-2401 *Rules of the Division of Occupational and Professional Licenses* – Omnibus Notice of Intent to Promulgate Rules – Zero-Based Regulation (ZBR) Negotiated Rulemaking – Negotiates Title 33, Chapter 04 – Bulletin Vol. 24-4

24.33.05, Rules for the Licensure of Athletic Trainers to Practice in Idaho

- 24-3305-2401** Adoption of Pending Rule (ZBR Chapter Rewrite), Bulletin Vol. 24-10 (PLR 2025)
24-3305-2401 Notice of Proposed Rulemaking (ZBR Chapter Rewrite), Bulletin Vol. 24-7

24-ZBRR-2401 *Rules of the Division of Occupational and Professional Licenses* – Omnibus Notice of Intent to Promulgate Rules – Zero-Based Regulation (ZBR) Negotiated Rulemaking – Negotiates Title 33, Chapter 05 – Bulletin Vol. 24-4

24.33.06, Rules for Licensure of Respiratory Therapists and Permitting of Polysomnographers in Idaho

24-3306-2401 Adoption of Pending Rule (ZBR Chapter Rewrite), Bulletin Vol. 24-10 (PLR 2025)

24-3306-2401 Notice of Proposed Rulemaking (ZBR Chapter Rewrite), Bulletin Vol. 24-7

24-ZBRR-2401 *Rules of the Division of Occupational and Professional Licenses* – Omnibus Notice of Intent to Promulgate Rules – Zero-Based Regulation (ZBR) Negotiated Rulemaking – Negotiates Title 33, Chapter 06 – Bulletin Vol. 24-4

24.33.07, Rules for the Licensure of Dietitians

24-3307-2401 Adoption of Pending Rule (ZBR Chapter Rewrite), Bulletin Vol. 24-10 (PLR 2025)

24-3307-2401 Notice of Proposed Rulemaking (ZBR Chapter Rewrite), Bulletin Vol. 24-7

24-ZBRR-2401 *Rules of the Division of Occupational and Professional Licenses* – Omnibus Notice of Intent to Promulgate Rules – Zero-Based Regulation (ZBR) Negotiated Rulemaking – Negotiates Title 33, Chapter 07 – Bulletin Vol. 24-4

24.35.01, Rules of the Outfitters and Guides Licensing Board

24-3501-2401 Notice of Proposed Rulemaking, Bulletin Vol. 24-8

24-3501-2401 Notice of Intent to Promulgate Rules – Negotiated Rulemaking, Bulletin Vol. 24-6

24.36.01, Rules of the Idaho State Board of Pharmacy

24-3601-2402 Notice of Proposed Rulemaking (ZBR Chapter Rewrite), Bulletin Vol. 24-8

24-ZBRR-2401 *Rules of the Division of Occupational and Professional Licenses* – Omnibus Notice of Intent to Promulgate Rules – Zero-Based Regulation (ZBR) Negotiated Rulemaking – Negotiates Title 36, Chapter 01 – Bulletin Vol. 24-4

24-3601-2401 Adoption of Temporary Rule, Bulletin Vol. 24-4 (eff. 7-1-24)T

24.37.01, Rules of the Idaho Real Estate Commission

24-3701-2401 Notice of Proposed Rulemaking (ZBR Chapter Rewrite), Bulletin Vol. 24-9

24-3701-2401 Notice of Intent to Promulgate Rules – Zero-Based Regulation (ZBR) Negotiated Rulemaking, Bulletin Vol. 24-6

24.39.10, Rules of the Idaho Electrical Board

24-3910-2402 Notice of Proposed Rulemaking, Bulletin Vol. 24-10

24-3910-2402 Notice of Intent to Promulgate Rules – Negotiated Rulemaking, Bulletin Vol. 24-7

24-3910-2401 Adoption of Temporary Rule, Bulletin Vol. 24-5 (eff. 4-19-24)T

24.39.40, Safety Rules for Elevators, Escalators, and Moving Walks

24-3940-2401 Notice of Intent to Promulgate Rules – Zero-Based Regulation (ZBR) Negotiated Rulemaking, Bulletin Vol. 24-7

24.39.60, Rules Governing Uniform School Building Safety

24-3960-2401 Notice of Intent to Promulgate Rules – Zero-Based Regulation (ZBR) Negotiated Rulemaking, Bulletin Vol. 24-7

24.39.70, Rules Governing Installation of Heating, Ventilation, and Air Conditioning Systems

24-3970-2401 Adoption of Temporary Rule, Bulletin Vol. 24-8 (eff. 7-10-24)T

24.39.80, Idaho Minimum Safety Standards and Practices for Logging

24-3980-2401 Notice of Intent to Promulgate Rules – Zero-Based Regulation (ZBR) Negotiated Rulemaking, Bulletin Vol. 24-7

24.39.90, Rules Governing the Damage Prevention Board

24-3990-2401 Notice of Proposed Rulemaking (ZBR Chapter Rewrite), Bulletin Vol. 24-8

24-3990-2401 Notice of Intent to Promulgate Rules – Zero-Based Regulation (ZBR) Negotiated Rulemaking, Bulletin Vol. 24-6

IDAPA 26 – DEPARTMENT OF PARKS AND RECREATION

26.01.37, Rules Governing Test Procedures and Instruments for Noise Abatement of Off Highway Vehicles

26-0137-2401 Notice of Proposed Rulemaking (ZBR Chapter Repeal), Bulletin Vol. 24-10

26-0137-2401 Notice of Intent to Promulgate Rules – Zero-Based Regulation (ZBR) Negotiated Rulemaking, Bulletin Vol. 24-8

IDAPA 31 – PUBLIC UTILITIES COMMISSION

31.21.01, Customer Relations Rules for Gas, Electric & Water Public Utilities (The Utility Customer Relations Rules)

- 31-2101-2401 Adoption of Pending Rule, Bulletin Vol. 24-10 (PLR 2025)
- 31-2101-2401 Notice of Proposed Rulemaking, Bulletin Vol. 24-8

31.41.01, Customer Relations Rules for Telephone Corporations Providing Services in Idaho Subject to Customer Service Regulation by the Idaho Public Utilities Commission

- 31-4101-2401 Notice of Proposed Rulemaking (ZBR Chapter Rewrite), Bulletin Vol. 24-10
- 31-4101-2401 Notice of Intent to Promulgate Rules – Zero-Based Regulation (ZBR) Negotiated Rulemaking, Bulletin Vol. 24-8

IDAPA 34 – SECRETARY OF STATE

34.08.01, Rules Governing Paid Signature Gatherers

- 34-0801-2401 Notice of Temporary and Proposed Rule (New Chapter), Bulletin Vol. 24-9 (eff. 7-1-24)T

IDAPA 35 – STATE TAX COMMISSION

35.01.03, Property Tax Administrative Rules

- 35-0103-2402 Notice of Temporary and Proposed Rule, Bulletin Vol. 24-9 (eff. 7-30-24)T

- 35-0103-2401 Notice of Proposed Rulemaking, Bulletin Vol. 24-9

- 35-0103-2401 Notice of Intent to Promulgate Rules – Negotiated Rulemaking, Bulletin Vol. 24-7

35.01.05, Idaho Motor Fuels Tax Administrative Rules

- 35-0105-2401 Notice of Proposed Rulemaking (ZBR Chapter Rewrite), Bulletin Vol. 24-9

- 35-0105-2401 Notice of Intent to Promulgate Rules – Zero-Based Regulation (ZBR) Negotiated Rulemaking, Bulletin Vol. 24-4

35.01.10, Idaho Cigarette and Tobacco Products Tax Administrative Rules

- 35-0110-2401 Notice of Proposed Rulemaking (ZBR Chapter Rewrite), Bulletin Vol. 24-9

- 35-0110-2401 Notice of Intent to Promulgate Rules – Zero-Based Regulation (ZBR) Negotiated Rulemaking, Bulletin Vol. 24-4

35.02.01, Tax Commission Administration and Enforcement Rules

- 35-0201-2401 Notice of Intent to Promulgate Rules – Negotiated Rulemaking, Bulletin Vol. 24-7 (rulemaking terminated by agency)

IDAPA 37 – DEPARTMENT OF WATER RESOURCES

37.03.01, Adjudication Rules

- 37-0301-2401 Notice of Proposed Rulemaking (ZBR Chapter Rewrite), Bulletin Vol. 24-10

- 37-0301-2401 Notice of Intent to Promulgate Rules – Zero-Based Regulation (ZBR) Negotiated Rulemaking, Bulletin Vol. 24-4

37.03.02, Beneficial Use Examination Rules

- 37-0302-2401 Notice of Proposed Rulemaking (ZBR Chapter Rewrite), Bulletin Vol. 24-10

- 37-0302-2401 Notice of Intent to Promulgate Rules – Zero-Based Regulation (ZBR) Negotiated Rulemaking, Bulletin Vol. 24-4

37.03.03, Rules and Minimum Standards for the Construction and Use of Injection Wells

- 37-0303-2401 Notice of Proposed Rulemaking (ZBR Chapter Rewrite), Bulletin Vol. 24-10

- 37-0303-2301 Notice of Intent to Promulgate Rules – Zero-Based Regulation (ZBR) Negotiated Rulemaking, Bulletin Vol. 23-4

37.03.09, Well Construction Standards Rules

- 37-0309-2401 Notice of Proposed Rulemaking (ZBR Chapter Rewrite), Bulletin Vol. 24-10

- 37-0309-2401 Notice of Intent to Promulgate Rules – Zero-Based Regulation (ZBR) Negotiated Rulemaking, Bulletin Vol. 24-4

37.03.11, Rules for Conjunctive Management of Surface and Ground Water Resources

- 37-0311-2401 Notice of Proposed Rulemaking, Bulletin Vol. 24-10

IDAPA 38 – IDAHO DEPARTMENT OF ADMINISTRATION

38.05.01, Rules of the Division of Purchasing

- 38-0501-2401 Notice of Intent to Promulgate Rules – Negotiated Rulemaking, Bulletin Vol. 24-10

44-0000-2400 Notice of Omnibus Rulemaking – Revocation of Final Rule – Certain provisions rendered null and void pertaining to IDAPA chapter 38.05.01– Bulletin Vol. 24-7

IDAPA 39 – IDAHO TRANSPORTATION DEPARTMENT

39-ZBRR-2402 *Rules of the Idaho Transportation Department* – Omnibus Notice of Intent to Promulgate Rules – Zero-Based Regulation (ZBR) Negotiated Rulemaking – Negotiates Title 03, Chapters 41, 60, 65 – Bulletin Vol. 24-7

39-ZBRR-2401 *Rules of the Idaho Transportation Department* – Omnibus Notice of Intent to Promulgate Rules – Zero-Based Regulation (ZBR) Negotiated Rulemaking – Negotiates Title 02, Chapters 03, 72, 75 – Bulletin Vol. 24-5

39.02.03, Rules Governing Vehicle Dealer's Principle Place of Business and Claims to the Idaho Consumer Asset Recovery Fund

39-0203-2401 Notice of Proposed Rulemaking (ZBR Chapter Rewrite), Bulletin Vol. 24-10

39-ZBRR-2401 *Rules of the Idaho Transportation Department* – Omnibus Notice of Intent to Promulgate Rules – Zero-Based Regulation (ZBR) Negotiated Rulemaking – Negotiates Title 02, Chapter 03 – Bulletin Vol. 24-5

39.02.72, Rules Governing Administrative License Suspensions

44-0000-2400 Notice of Omnibus Rulemaking – Revocation of Final Rule – Certain provisions rendered null and void pertaining to IDAPA chapter 39.02.72 – Bulletin Vol. 24-7

39-ZBRR-2401 *Rules of the Idaho Transportation Department* – Omnibus Notice of Intent to Promulgate Rules – Zero-Based Regulation (ZBR) Negotiated Rulemaking – Negotiates Title 02, Chapter 72 – Bulletin Vol. 24-5 (rulemaking terminated)

39.02.75, Rules Governing Names on Driver's Licenses and Identification Cards

39-0275-2401 Notice of Proposed Rulemaking, Bulletin Vol. 24-10

39-ZBRR-2401 *Rules of the Idaho Transportation Department* – Omnibus Notice of Intent to Promulgate Rules – Zero-Based Regulation (ZBR) Negotiated Rulemaking – Negotiates Title 02, Chapter 75 – Bulletin Vol. 24-5

39.03.41, Rules Governing Traffic Control Devices

39-0341-2401 Notice of Proposed Rulemaking, Bulletin Vol. 24-10

39-ZBRR-2402 *Rules of the Idaho Transportation Department* – Omnibus Notice of Intent to Promulgate Rules – Zero-Based Regulation (ZBR) Negotiated Rulemaking – Negotiates Title 03, Chapter 41 – Bulletin Vol. 24-7

39.03.60, Rules Governing Outdoor Advertising, Accident Memorials, and Other Official Signs

39-0360-2401 Notice of Proposed Rulemaking (ZBR Chapter Rewrite), Bulletin Vol. 24-10

39-ZBRR-2402 *Rules of the Idaho Transportation Department* – Omnibus Notice of Intent to Promulgate Rules – Zero-Based Regulation (ZBR) Negotiated Rulemaking – Negotiates Title 03, Chapter 60 – Bulletin Vol. 24-7

39.03.65, Rules Governing Traffic Minute Entries

39-0365-2401 Notice of Proposed Rulemaking (ZBR Chapter Rewrite), Bulletin Vol. 24-10

39-ZBRR-2402 *Rules of the Idaho Transportation Department* – Omnibus Notice of Intent to Promulgate Rules – Zero-Based Regulation (ZBR) Negotiated Rulemaking – Negotiates Title 03, Chapter 65 – Bulletin Vol. 24-7

IDAPA 42 – IDAHO WHEAT COMMISSION

42.01.01, Rules of the Idaho Wheat Commission

42-0101-2401 Notice of Intent to Promulgate Rules – Zero-Based Regulation (ZBR) Negotiated Rulemaking, Bulletin Vol. 24-8

IDAPA 43 – IDAHO OILSEED COMMISSION

43.01.01, Rules Governing the Idaho Oilseed Commission

43-0101-2401 Notice of Proposed Rulemaking (ZBR Chapter Rewrite), Bulletin Vol. 24-10

43-0101-2401 Notice of Intent to Promulgate Rules – Zero-Based Regulation (ZBR) Negotiated Rulemaking, Bulletin Vol. 24-8

IDAPA 44 – OFFICE OF THE ADMINISTRATIVE RULES COORDINATOR

44-0000-2401 Notice of Omnibus Rulemaking – Revocation of Final Rule – Certain provisions rendered null and void pertaining to IDAPA 15.04.01 – Bulletin Vol. 24-8

- 44-0000-2400** Notice of Omnibus Rulemaking – Revocation of Final Rule – Certain provisions rendered null and void pertaining to IDAPA chapters 04.11.01, 11.04.01, 16.05.03, 20.01.01, 21.01.01, 38.05.01, 39.02.04, 39.02.72, 52.01.03, and 59.01.01 – Bulletin Vol. 24-7

IDAPA 47 – DIVISION OF VOCATIONAL REHABILITATION

47.01.01, Rules Governing Vocational Rehabilitation Services

- 47-0101-2401** Notice of Proposed Rulemaking, Bulletin Vol. 24-10

IDAPA 50 – COMMISSION OF PARDONS AND PAROLE

50.01.01, Rules of the Commission of Pardons and Parole

- 50-0101-2401** Notice of Temporary and Proposed Rule, Bulletin Vol. 24-10 (eff. 7-1-24)T

IDAPA 52 – IDAHO STATE LOTTERY COMMISSION

52.01.03, Rules Governing Operations of the Idaho State Lottery

- 44-0000-2400** Notice of Omnibus Rulemaking – Revocation of Final Rule – Certain provisions rendered null and void pertaining to IDAPA chapter 52.01.03 – Bulletin Vol. 24-7

- 52-0103-2401** Notice of Temporary and Proposed Rule, Bulletin Vol. 24-6 (eff. 7-1-24)T

IDAPA 58 – DEPARTMENT OF ENVIRONMENTAL QUALITY

TMDLs:

58.01.01, Rules for the Control of Air Pollution in Idaho

- 58-0101-2401** Notice of Proposed Rulemaking, Bulletin Vol. 24-9

58.01.02, Water Quality Standards

- 58-0102-2401** Notice of Proposed Rulemaking, Bulletin Vol. 24-8

58.01.03, Individual/Subsurface Sewage Disposal Rules and Rules for Cleaning of Septic Tanks

- 58-0103-2301** Notice of Proposed Rulemaking (ZBR Chapter Rewrite), Bulletin Vol. 24-6

- 58-0103-2301** Notice of Intent to Promulgate Rules – Zero-Based Regulation (ZBR) Negotiated Rulemaking, Bulletin Vol. 23-9

58.01.05, Rules and Standards for Hazardous Waste

- 58-0105-2401** Notice of Proposed Rulemaking, Bulletin Vol. 24-8

58.01.08, Idaho Rules for Public Drinking Water Systems

- 58-0108-2401** Notice of Proposed Rulemaking, Bulletin Vol. 24-9

58.01.10, Rules Regulating the Disposal of Radioactive Materials Not Regulated Under the Atomic Energy Act of 1954, As Amended

- 58-0110-2301** Notice of Proposed Rulemaking (ZBR Chapter Rewrite), Bulletin Vol. 24-8

- 58-0110-2301** Notice of Intent to Promulgate Rules – Zero-Based Regulation (ZBR) Negotiated Rulemaking, Bulletin Vol. 23-9

58.01.14, Rules Governing Fees for Environmental Operating Permits, Licenses, and Inspection Services

- 58-0114-2401** Notice of Proposed Rulemaking (ZBR Chapter Rewrite, Fee Rule), Bulletin Vol. 24-9

- 58-0114-2401** Notice of Intent to Promulgate Rules – Zero-Based Regulation (ZBR) Negotiated Rulemaking, Bulletin Vol. 24-4

58.01.22, Rules for Administration of Planning Grants for Drinking Water and Wastewater Facilities

- 58-0122-2401** Notice of Proposed Rulemaking (ZBR Chapter Rewrite), Bulletin Vol. 24-9

- 58-0122-2401** Notice of Intent to Promulgate Rules – Zero-Based Regulation (ZBR) Negotiated Rulemaking, Bulletin Vol. 24-4

58.01.23, Contested Case Rules and Rules for Protection and Disclosure of Records

- 58-0123-2401** Notice of Temporary and Proposed Rule, Bulletin Vol. 24-7 (eff. 7-1-24)T

58.01.24, Standards and Procedures for Application of Risk Based Corrective Action at Petroleum Release Sites

- 58-0124-2401*** Notice of Proposed Rulemaking (ZBR Chapter Rewrite), Bulletin Vol. 24-8

*Changes chapter name from: “Standards and Procedures for Application of Risk Based Corrective Action at Petroleum Release Sites”

58-0124-2401 Notice of Intent to Promulgate Rules – Zero-Based Regulation (ZBR) Negotiated Rulemaking, Bulletin Vol. 24-3

IDAPA 59 – PUBLIC EMPLOYEE RETIREMENT SYSTEM OF IDAHO (PERSI)

59.01.01, Rules for the Public Employee Retirement System of Idaho (PERSI)

44-0000-2400 Notice of Omnibus Rulemaking – Revocation of Final Rule – Certain provisions rendered null and void pertaining to IDAPA chapter 59.01.01 – Bulletin Vol. 24-7

IDAPA 61 – STATE PUBLIC DEFENSE COMMISSION

61-0000-2400 **Rules of the Idaho State Public Defense Commission** – Notice of Omnibus Rulemaking – Adoption of Temporary Rule – Reauthorizes Title 01, Chapters 01-04 – Bulletin Vol. 24-4 (eff. *sine die* 2024)T [temporary rule expires 10-1-24]

61.01.01, [Rule Expired] General Provisions and Definitions

61-0000-2400 **Rules of the Idaho State Public Defense Commission** – Notice of Omnibus Rulemaking – Adoption of Temporary Rule – Reauthorizes Title 01, Chapter 01 – Bulletin Vol. 24-4 (eff. *sine die* 2024)T [temporary rule expires 10-1-24]

61.01.02, [Rule Expired] Requirements and Procedures for Representing Indigent Persons

61-0000-2400 **Rules of the Idaho State Public Defense Commission** – Notice of Omnibus Rulemaking – Adoption of Temporary Rule – Reauthorizes Title 01, Chapter 02 – Bulletin Vol. 24-4 (eff. *sine die* 2024)T [temporary rule expires 10-1-24]

61.01.03, [Rule Expired] Records, Reporting, and Review

61-0000-2400 **Rules of the Idaho State Public Defense Commission** – Notice of Omnibus Rulemaking – Adoption of Temporary Rule – Reauthorizes Title 01, Chapter 03 – Bulletin Vol. 24-4 (eff. *sine die* 2024)T [temporary rule expires 10-1-24]

61.01.04, [Rule Expired] Financial Assistance and Training Resources

61-0000-2400 **Rules of the Idaho State Public Defense Commission** – Notice of Omnibus Rulemaking – Adoption of Temporary Rule – Reauthorizes Title 01, Chapter 04 – Bulletin Vol. 24-4 (eff. *sine die* 2024)T [temporary rule expires 10-1-24]

IDAPA 63 – IDAHO COUNCIL ON DOMESTIC VIOLENCE AND VICTIM ASSISTANCE

63.05.04, Domestic Violence Council Grants

**(Re-designated from IDAPA 16.05.04 to 63.05.04)*

63-0504-2400 **IDAPA 63 – IDAHO COUNCIL ON DOMESTIC VIOLENCE AND VICTIM ASSISTANCE** – Notice of Assignment of New IDAPA Designation Number – Redesignated to **IDAPA 63, Title 05, Chapter 04** from **IDAPA 16, Title 05, Chapter 04** – Bulletin Vol. 24-6 (eff. 7-1-24)

Subject Index

- A**
- Abbreviations 32, 41, 78, 97, 217
 - APAP, Agricultural Pollution Abatement Plan 32
 - APC 217
 - APHIS, Animal & Plant Health Inspection Service 42
 - APHIS, Animal Plant Health Inspection Service 97
 - ASC 217
 - AVIC, Area Veterinarian in Charge 98
 - AWP 217
 - BMP, Best Management Practice 32
 - CFR, Code of Federal Regulations 42, 98
 - CMS 218
 - CPT 218
 - CVI, Certificate of Veterinary Inspection 42
 - DCEPA, Dimethyl Tetrachloroterephthalate 32
 - DEQ, Department of Environmental Quality 32
 - EDI 218
 - EPA, Environmental Protection Agency 32
 - FDA 78
 - FROI 218
 - HAL, Health Advisory Level 32
 - HCPCS 218
 - IAIABC 218
 - ISIF 218
 - LSS 218
 - MCL, Maximum Contaminant Level 32
 - MSDRG 218
 - NASAHQ, National Assembly of State Animal Health Officials 42
 - NCCI 218
 - NDC 218
 - NRCS, Natural Resources Conservation Service 32
 - PEMMP, Post Exposure Monitoring and Management Plan 98
 - PMP, Pesticide Management Plan 32
 - QAPP, Quality Assurance Project Plan 32
 - QMP, Quality Management Plan 32
 - RBRVS 218
 - RfD, Reference Dose 32
 - RVU 218
 - SCC, Soil Conservation Commission 32
 - SROI 218
 - USDA, United States Department of Agriculture 32, 42, 98
 - VS, Veterinary Services 42, 98
 - Abbreviations, IDAPA 02.04.15 67
 - AFO 67
 - CAFO 67
 - IPDES 67
 - NMP 67
 - NRCS 67
 - PSI 67
 - Abbreviations, IDAPA 37.03.02 321
 - AF 321
 - CFS 321
 - P.D. or POD 321
 - P.U. or POU 321
 - USGS 321
 - Abbreviations, Subchapter A 44
 - AGID, Agar gel immunodiffusion 44
 - c-ELISA, Competitive Enzyme Linked Immunosorbent Assay 44
 - EIA, Equine Infectious Anemia 44
 - NPIP, National Poultry Improvement Plan 44
 - Able To Work 156
 - Able to Perform Some Type of Work 156
 - Able to Work Part-Time 156
 - Disability Compensation 156
 - Illness Provision 156
 - Illness Provision as Applied to Transitional or Reopened Claim 157
 - Withdrawing From Labor Market Because of Illness 157
 - Access To Emergency Services 301
 - Accountability 146
 - Exams 146
 - Student Work & Ethical Conduct 146
 - Teacher Interaction 146
 - Accounting & Delinquency Control Cancellation of Refund Warrants 188
 - Erroneous Wage Reports 188
 - Notification of Underpayments 188
 - Accredited Institution 113
 - Actinomycosis (Lump Jaw) 54
 - Public Livestock Markets 54
 - Selling Diseased Animal 54
 - Additional Bonding Requirements 23
 - Additional Import Requirements, Sheep Board May Impose 98
 - Additional Qualifications For Registration 262
 - Exemption Review 263
 - Felony Conviction 263
 - Fraud in Application Process 263
 - Address, Office Hours, Telephone, Fax Numbers, Web Address 31
 - Administration 456
 - Permits 457
 - Selection Methods & Criteria 456
 - Administration Of IPDES Program 68
 - Administrative Appeals 30, 148, 155, 176, 284
 - Adoption Of Federal Slamming Regulations 303
 - Advisory Committee 38
 - Evaluate Effectiveness 39
 - Recommendations 39
 - Research 39
 - Review Existing Information 38
 - Agricultural Commodities-- Warehouse Obligations 22
 - Alien Eligibility 157
 - Benefit Eligibility 157
 - Alternate Routes To Certification Alternative Authorization -- Content Specialist 123
 - Alternative Authorization - Pupil Service Staff 124
 - Alternative Authorization -- Teacher to New Certification 123
 - Alternative Authorization - Certification 123
 - Amending Tariff 23
 - Amendment Fees 310
 - Amount Of Bond, Irrevocable Letter Of Credit, Certificate Of Deposit, Or Single Bond Bonding Requirement 20
 - Single Bond, Irrevocable Letter of Credit or Certificate of Deposit 20
 - Amount Of Deposit -- LECS 287
 - Animal Movement In Quarantine Area 58
 - Animals In Transit 99
 - Animals In Transit At Time Of Declared Emergency 58
 - Appeals To Appeals Examiner – Form & Manner Of Filing Of Notices Of Appeal 150
 - Filing of Notices of Appeal 150
 - Form of Notices of Appeal 150
 - Appendix A, Construction of Drilled Wells 391
 - Applicability 98, 318
 - Examination 318
 - Examination Fee 318
 - Proof of Beneficial Use 318
 - Re-Examination 318
 - Application Of Payments On Delinquent Accounts
 - First Application 178
 - Second Application 178
 - Subsequent Applications 178
 - Third Application 178
 - Application Procedures 255
 - Applications 255
 - Dates 256
 - Lack of Activity 256
 - References 256
 - Application Process 107
 - Announcement of Award 107
 - Applications 107

- Communication with State Officials 107
- Appraisal Procedure For Animals
 - Depopulated 59
 - Animal Appraisal 59
 - Dispute of Appraisal 59
- Areas Determined To Have A Common Ground Water Supply 408
 - Eastern Snake Plain Aquifer 408
- Areas Of Drilling Concern 389
 - Additional Requirements 390
 - Bond Requirement 389
 - General 389
- Artificial Insemination 47
 - Examination 47
 - Issuance Denial 47
 - License Application 47
 - License Expiration 47
 - License Renewal 47
 - Passing Examination 47
 - Renewal Delinquency 47
 - Temporary License 47
 - Training 47
- Authority Of Representative 321
 - Evidence of Authority 321
 - Responsibility 321
- Authorizations, Prohibitions & Exemptions 342
 - Authorizations 342
 - Exemptions 343
 - Prohibitions 342
 - Variance of Methods 343
- Automatic Recording 301
- Availability Of The "Manual On Uniform Traffic Control Devices For Streets & Highways & Other Referenced Documents 442
- Available For Work 158
 - Availability Requirements 158
 - Child Care 158
 - Compelling Personal Circumstances 158
 - Conscientious Objection 158
 - Contract Obligation 159
 - Distance to Work 159
 - Domestic Circumstances 159
 - Equipment 159
 - Evidence 159
 - Experience or Training 159
 - Full-Time/Part-Time Work 159
 - Incarceration/Work Release 159
 - Jury Duty/Subpoenas 159
 - Licensing or Government Restrictions 159
 - Moving to Remote Area 159
 - Public Official 159
 - Public Service 159
 - Restricting Work to Within the Home 159
 - School Attendance or a Training Course 159
 - Temporary Absence From Local Labor Market to Seek Work 160
 - Time 160
 - Transportation Difficulties 160
 - Unreasonable Restrictions on Working Conditions 160
 - Vacation 160
 - Wages 160
 - Waiver of Two-Year Training Limitation 160
- B**
- Bear Identification 202
- Bentonite Grout 368
- Billing 288
- Billing Errors, Billing Under Incorrect Rates, Or Failure To Bill 290
 - Additional Payments 290
 - Billing Errors -- Failure to Bill 290
 - Billing Under Incorrect Rates 290
 - Rebilling Time Period 290
 - Refunds 290
- Billing Prohibited -- Billing Disputes 290
 - Billing Disputes 291
 - Unauthorized Charges 291
- Biologicals, Animal Industry 48
- Board, Lodging, Meals 189
 - Cash Value 189
 - Meals & Lodging Not Included in Gross Wages 189
 - Meals or Lodging for Employer Convenience 189
 - Subsistence Remuneration 190
- Bonds Of Out-Of-State Permittees & Licensees 453
- C**
- Canceling Claims 161
- Cancer Eye - Epithelioma 47
 - Animal Rendering Plants 47
 - Fur Farms 47
- Certificates Issued To Applicants 113
- Certificates Of Veterinary Inspection 46
 - Approved Certificates 46
 - Idaho Certificates 46
- Certification Of Teachers Trained In Foreign Institutions 113
- Cessation Of Service In A Service Area 296
 - Competitive Local Service Provider 296
 - Single Local Service Provider 296
- Change 236
- Chemical Specific Pesticide Management Plans PMPs
 - Creating PMPs 32
- Chemical Specific PMPs 32
 - PMP Compliance 33
- Chips 368
- Circumstances Of An Animal Health Emergency 57
- Claimants With Disabilities 157
- Additional Eligibility Requirements 158
- Availability Requirement 158
- Burden of Proof 158
- Claims Of Exemption 181
- Class V
 - Criteria & Standards 354
 - Additional Information 356
 - Application Information Required 356
 - Application Processing 358
 - Application Requirements 355
 - Class V Deep Injection Well Requirements 355
 - Class V Shallow Injection Well Requirements 354
 - Conditions of Permanent Decommissioning 361
 - Consideration 359
 - Construction Requirements 359
 - Criteria for Location & Use of Class V Wells Requiring Permits 362
 - Draft Permit 358
 - Duration of Approved Permits 361
 - Fact-Finding Hearings 358
 - Inter-Agency Cooperation 355
 - Issuance of Permit 359
 - Monitoring, Record Keeping & Reporting Requirements 363
 - Open-Loop Heat Pump Return Wells (Subclass 5A7) 358
 - Operational Conditions 360
 - Other Information 358
 - Permanent Decommission 355
 - Permit Assignable 365
 - Permit Conditions & Requirements 359
 - Permit Requirements 355
 - Public Notice 358
 - Review by the Directors of Other State Agencies 358
 - Standards for Quality of Fluids Injected into Class V Wells 361
 - Standards for the Quality of Fluids Injected by Subclass 5A7 Wells (Open-Loop Heat Pump Return) 363
 - Standards For The Quality of Injected Fluids & Criteria For Location & Use 361
 - The Director's Action On Draft Permits & Duration Of Approved Permits 359
- Class V Injection Well Construction And Operation Requirements 348
 - Conditions of Permanent Decommissioning 349
 - Construction Requirements 348
 - Duration of Approved Permits 350
 - Operational Conditions and Requirements 348

- Class V Injection Well
 - Requirements 344
 - Additional Information 345
 - Application Information
 - Required 344
 - Permit Required for Class V Deep Injection Wells 344
 - Permit Requirements for Class V Shallow Injection Wells 344
- Class V Injection Well Requirements – Application Processing 346
 - Draft Permit Final Review and Consideration 347
 - Draft Permit Preparation 346
 - Fact-Finding Hearings 347
 - Issuance of Permit 348
 - Open-Loop Heat Pump Return Wells (Subclass 5A7) 347
 - Permit Conditions and Requirements 348
 - Permit Decision Notice 348
 - Public Notice 347
 - Review by the Directors of Other State Agencies 347
- Class V Shallow Injection Well Requirements 344
 - Authorization 344
 - Cessation of Injection Well Activity 344
 - Decommission 344
 - Inter-Agency Cooperation 344
 - Inventory Fees 344
- Classification Of Injection Wells 339
 - Subclassification 341
- Cleaning & Disinfection 103
- Cleaning & Disinfection Of Animal Conveyance 60
- Cleaning & Disinfection Of Premises 60
- Collection Of Samples For CWD Testing 74
 - Failure to Meet Annual CWD Tissue Submission Requirement 74
 - Non-Testable or Samples That Do not Contain Appropriate Tissues 74
- Commodity Indemnity Fund 23
 - Exemptions to Assessments 24
 - Rate of Assessment 23
- Communication With Appeals Staff 152
 - Issues of Fact 153
 - Prohibition of Ex Parte Contacts 153
 - Reporting Prohibited Contacts 153
- Compensation For Animals Destroyed 59
- Compensation For Appraised Animals 59
- Compensation For Labor Employed 59
 - Cleaning & Disinfection 60
 - Disposal of Animals 59
- Compensation For Property Destroyed 60
 - Actual Value 60
 - Property Destroyed Otherwise 60
- Complaint Procedure 297
- Complaint To Commission 297
- Complaint To Telephone Company 297
 - Complaint 297
 - Informal Complaint 297
 - Investigation by Utility 297
 - Service Maintained 297
 - Termination of Service - Undisputed Bills 297
- Compliance 454
 - Improper Installation 454
 - Maintenance 454
 - Traffic Hazard 454
- Compliance With Idaho Pollutant Discharge Elimination System Rules 68
- Compromise Of Penalty & Civil Penalty 177
 - Good Cause 177
- Condemnation & Destruction Of Diseased Animals Or Flocks 102
 - Animals or Flocks Condemned 102
 - Animals or Flocks Infected 102
- Condemnation Of Infected, Exposed, Or Susceptible Animals 58
- Conduct Of Appeals Hearing 151
 - Challenge of General Knowledge 152
 - Closing Arguments 152
 - Continuance 151
 - Disruptive Individuals 152
 - Evidence 152
 - Exhibits and Recordings 151
 - Failure to Respond to Subpoena 152
 - No Appearance Hearings 151
 - Order of Witnesses 152
 - Rehearing 151
 - Role of Appeals Examiner 152
 - Subpoenas 152
 - Telephone Hearings 151
 - Type of Hearing 152
 - Undecided Issues 152
 - Witness Fees 152
- Conflict With Telephone Tariffs Or Price Lists 286
- Construction Of Cold Water Wells
 - Access Port or Pressure Gage 382
 - Alternative Methods for Sealing Wells 381
 - Amount of Chlorine Needed Per 100 Feet of Water in Well 384
 - Cathodic Protection Wells 381
 - Closed Loop Heat Exchange Wells 382
 - Completion of a Well 383
 - Decommissioning of Wells 382
 - Disinfection & Contamination 384
 - Drilling Fluids or Drilling Additives 384
 - Explosives 384
 - Hydraulic Fracturing 384
 - Injection Wells 381
 - Liner 378
 - Minimum Single-Wall Steel Well Casing Thickness¹ for Selected Diameters (inches) 377
 - Monitoring and Remediation Wells 381
 - Pitless Adapters 384
 - Pump Installation 384
 - Sand Production 385
 - Screen 378
 - Sealing Artesian Wells 380
 - Sealing of Wells 379
 - Separation of Well from Use of Approved Sealing Materials & Required Annular Space 378
 - Well Development & Testing 385
- Construction Of Ground Water Wells 374
 - Casing 376
 - General 374
 - Records 376
 - Waivers 375
- Construction Of Low Temperature Geothermal Resource Wells & Bonding 385
 - Blow Out Prevention Equipment 387
 - Casing 386
 - Decommissioning of Wells 387
 - General 385
 - Repair of Wells 387
 - Sealing of Casing 387
 - Well Owner Bonding 386
- Contents Of A Chemical Specific PMP 33
 - Elements That May be Included in a PMP 33
 - Required Elements of a PMP 33
- Contents Of Notice Of Intent To Terminate Local Exchange Service 293
 - Contents of Notice 293
- Continuing Eligibility 108
 - Academic Progress 109
 - Eligibility Following Interruption of Continuous Enrollment 109
 - Renewal Application 109
 - Requirements 108
- Criteria 417
 - Applicant's First Name 418
 - Change of Name on Record, Criteria 419
 - Common Law Marriage 418
 - Designations of Names 418
 - Divorced Applicants' Names 418
 - Drivers License & Identification Card Names 417
 - Legal Name 417

- Married Applicants' Names 418
- Stepparents' Name 417
- Titles or Nicknames 419
- Criteria for Location and Use of Class V Wells Requiring Permits 351
 - General 351
- D**
- Dairy Goats 99
- Date Of Service Of
 - Determinations 150
- Deceased Claimants 161
- Declaration Of An Animal Health Emergency 57
 - Disease Presence 57
 - Eradicated Diseases 57
 - Specific Diseases 57
- Declaratory Ruling Procedures 149
 - Disposition of Petitions for Declaratory Rulings 149
 - Filing Petition 149
 - Form of Petition 149
 - Legal Assertions 149
- Definitions 412
 - Advertising Structure(s) or Sign(s), or Advertising Display(s) 444
 - Bypassed Community Signs 444
 - Community Official Signs 445
 - Customary Maintenance 445
 - Department 445
 - Directional Signs 445
 - Federal or State Laws 445
 - Freeway 445
 - Interstate System or Interstate Highway 446
 - Maintain or Place 446
 - Maintenance 446
 - Parkland 446
 - Permit 446
 - Permit Application 446
 - Primary System or Primary Highway 446
 - Public Service Signs 446
 - Public Utility Signs 447
 - Regionally Known 447
 - Rest Area 447
 - Service Club & Religious Notices 447
 - Sign 447
 - State 447
 - Telephone 413
 - Territorial or Zoning Jurisdiction 447
 - Vehicle Dealer File System 412
 - Vehicle Dealer Sign Requirements 413
- Definitions – Conduct Of Fishing 207
 - Catch-and-Release 207
 - Commercial Fishing 207
 - Fly Fishing 207
 - Harvest 207
 - Ice Fishing 207
 - Length 207
 - Snagging 207
- Spearfishing 207
- Trolling 207
- Unattended Line 207
- Definitions & Abbreviations 192
 - Alcohol 192
 - Alcohol Analysis 192
 - Approved Vendor 192
 - Breath Alcohol Analysis 192
 - Breath Alcohol Test 192
 - Breath Alcohol Testing Sequence 192
 - Breath Testing Specialist (BTS) 193
 - Calibration 193
 - Certificate of Analysis 193
 - Certificate of Instrument Calibration 193
 - Department 193
 - Deprivation Period 193
 - Evidentiary Test 193
 - Idaho State Police Forensic Services (ISPFs) 193
 - Laboratory 193
 - MIP/MIC 193
 - Monitoring Period 193
 - Observation Period 193
 - Operator 193
 - Operator Certification 193
 - Performance Verification 193
 - Performance Verification Standard 194
 - Proficiency Testing 194
 - Quality Control 194
 - Testing Sequence 194
 - Urine Alcohol Analysis 194
- Definitions 17.01.01 214
 - Adjustor 214
 - Ambulatory Payment Classification (APC) 214
 - Ambulatory Surgery Center (ASC) 214
 - Approval by Commission 214
 - Available Funds 214
 - Average Wholesale Price (AWP) 215
 - Charge 215
 - Charging Lien 215
 - Claim 215
 - Claimant 215
 - Claims Administrator 215
 - Claims Services 215
 - Commission 215
 - Critical Access Hospital 215
 - Current Procedural Terminology (CPT) 215
 - Death Claim 216
 - Electronic Data Interchange (EDI) 216
 - Fee Agreement 216
 - First Degree of Consanguinity 216
 - First Report of Injury (FROI) 216
 - Gross Direct Premiums Written 216
- Healthcare Common Procedure Coding System (HCPCS) 216
- Hospital 216
- IAIABC EDI Release Claims 216
- Impairment Rated Claim 216
- Implantable Hardware 216
- Indemnity Benefits 216
- Indemnity Claim 216
- Legacy Claim 216
- Litigated Case 217
- Medical Only Claim 217
- Medical Report 217
- Medicare Severity - Diagnosis Related Group 217
- Net Premiums Written 217
- Payor 217
- Payroll 217
- Pharmacy 217
- Termination of Disability 217
- Time Loss Claim 217
- Trading Partner 217
- Trading Partner Agreement 217
- Definitions, IDAPA 02.02.12 16
 - Cash Sale 16
 - Commodity Indemnity Fund (CIF) 16
 - Credit-Sale Contract 16
 - Dealer 16
 - Deposit for Service 16
 - NPE, No Price Established 17
 - Open Storage 17
 - Warehouse 17
- Definitions, IDAPA 02.03.01 31
 - Aquifer 31
 - Beneficial Uses 31
 - Best Management Practice 31
 - Constituent 31
 - Contaminant 31
 - Contamination 31
 - Ground Water 31
 - Health Advisory Level 31
 - Maximum Contaminant Level 31
 - Pesticide Management Standard 31
 - Pesticide Use 31
 - Projected Future Beneficial Uses 31
 - Reference Dose 32
 - Reference Point 32
 - Susceptibility 32
 - Vulnerability 32
- Definitions, IDAPA 02.04.03, Subchapter A 42
 - Accredited Veterinarian 42
 - Animal 42
 - Approved Pseudorabies Vaccine 42
 - Cachexia 42
 - Epithelioma 43
 - Equidae 43
 - Exposed Livestock 43
 - Gamebirds 43
 - Garbage 43
 - Hatching Eggs 43

- Herd 43
- Infected Livestock 43
- Interstate Movement 43
- Intrastate Movement 43
- Known Infected Herd 43
- Livestock 43
- Necrosis 43
- Negative 43
- Neoplastic Tissue 43
- Official Pseudorabies Test 43
- Orbital Region 43
- Positive 43
- Poultry 43
- Pseudorabies 44
- Quarantine 44
- Quarantined 44
- Quarantined Area 44
- Ratites 44
- Registered Veterinarians 44
- Restrain 44
- Stockyards 44
- Suppuration 44
- Suspect 44
- Swine 44
- Swine Feedlot 44
- Waterfowl 44
- Wildfowl 44
- Definitions, IDAPA 02.04.03,
Subchapter B 56
 - Animal Health Emergency 56
 - Animals 56
 - Conveyance 56
 - Domestic Cervidae 56
 - Emergency Disease 56
 - Epidemiology 56
 - Exposed 56
 - Federal Animal Health
Official 56
 - Foreign Animal Disease 56
 - Infected Zone 56
 - Livestock 56
 - Operator 56
 - Premises 56
 - Quarantine 56
 - Quarantine Area 56
 - State Animal Health Official 57
 - Surveillance Zone 57
- Definitions, IDAPA 02.04.15 66
 - Animal 66
 - Animal Feeding Operation 66
 - Compost 66
 - Concentrated Animal Feeding
Operation 66
 - Discharge 66
 - Idaho Pollutant Discharge
Elimination System
(IPDES) 66
 - Land Application 66
 - Large Concentrated Animal
Feeding Operation 66
 - Medium Concentrated Animal
Feeding Operation 66
 - Operate 67
 - Operator 67
- Phosphorus Site Index 67
- Runoff 67
- Slaughter & Feeder Cattle 67
- Small Concentrated Animal
Feeding Operation 67
- Definitions, IDAPA 02.04.19 70
 - Approved Laboratory 70
 - Approved Slaughter
Establishment 70
 - Area Veterinarian in Charge 70
 - Breed Associations &
Registries 70
 - Cervid Herd 70
 - Cervidae 70
 - Chronic Wasting Disease
(CWD) 70
 - Commingle 70
 - Custom Exempt Slaughter
Establishment 71
 - CWD-Adjacent Herd 71
 - CWD-Exposed Animal 71
 - CWD-Exposed Herd 71
 - CWD-Positive Cervid 71
 - CWD-Positive Herd 71
 - CWD-Suspect Cervid 71
 - CWD-Suspect Herd 71
 - Death Certificate 71
 - Designated Epidemiologist 71
 - Disposal 71
 - Domestic Cervidae 71
 - Domestic Cervidae Ranch 71
 - Electronic Identification 71
 - Endemic Area 71
 - Escape 72
 - Federal Animal Health
Official 72
 - Harvest 72
 - Herd of Origin 72
 - Herd Status 72
 - Individual CWD Herd Plan 72
 - Intrastate Movement
Certificate 72
 - Limited Contact 72
 - National CWD Herd Certification
Program 72
 - Official CWD Test 72
 - Official Identification 72
 - Operator 72
 - Premises 72
 - Quarantine 72
 - Quarantine Facility 72
 - Ranch Management Plan 72
 - Re-Identification 72
 - Restrain 73
 - Restricted Movement Permit 73
 - Source Herd 73
 - State Animal Health Official 73
 - Status Date 73
 - Tissue 73
 - Trace Back Herd 73
 - Trace Forward Herd 73
 - Traceback 73
 - Wild Cervidae 73
 - Wild Ungulate 73
- Wild Ungulate Cooperative Herd
Plan 73
- Definitions, IDAPA 02.05.01 77
 - Petition 78
 - Petitioner 78
- Definitions, IDAPA 02.08.01 95
 - Accredited Veterinarian 95
 - Animals 95
 - Authorized Federal Inspector 95
 - Authorized State Inspector 95
 - Board 95
 - Breeding Stock 95
 - Brucella Ovis Test Negative 95
 - Brucella Ovis Test Positive 95
 - Brucella Ovis Test Suspect 95
 - Brucellosis 95
 - Certificate 95
 - Commercial Low-Risk Goats 95
 - Contemporary Lambing
Group 95
 - Exposed 95
 - Federal Animal Health
Official 95
 - Flock 95
 - Flock Plan 96
 - Goats Requiring Premises/Flock
Identification Number 96
 - Idaho Premises/Flock
Identification Number 96
 - Low Risk Commercial Sheep 96
 - Negative 96
 - Official Individual
Identification 96
 - Post Exposure Monitoring &
Management Plan 96
 - Premises 96
 - Quarantine 96
 - Scrapie 96
 - Scrapie Exposed Animal 96
 - Scrapie Flock Certification
Program 96
 - Scrapie High Risk Animal 96
 - State Scrapie Certification
Board 97
 - Terminal Feedlot 97
 - Trace 97
- Definitions, IDAPA 08.02.02 111
 - Accredited Institution 111
 - Clinical Experience 111
 - Clinical Practice 111
 - Credential 111
 - Endorsement 111
 - Field Experience 111
 - Individualized Professional
Learning Plan 111
 - Institutional
Recommendation 111
 - Internship 112
 - Local Education Agency
(LEA) 112
 - Mentoring Program 112
 - Paraprofessional 112
 - Pedagogy 112
 - Portfolio 112

- Practicum 112
Semester Credit Hours 112
Student Learning Objective (SLO) 113
Student Teaching 113
Teacher of Record 113
Definitions, IDAPA 08.02.03 128
Achievement Standards 128
Advanced Opportunities 128
All Students 128
Applied Science 128
Assessment 128
Assessment Standards 128
Career Pathway Plan 128
Career Technical Education 129
College and Career Readiness 129
Content Standards 129
Criteria 129
Diploma 129
Dual Credit 129
Idaho Standards Achievement Tests 129
International Baccalaureate (IB) 129
Laboratory 129
Localized Pathway 129
Portfolio 129
Proficiency 130
Project Based Learning 129
Standards 130
Technical Competency Credit 130
Technology Education 130
Unique Student Identifier 130
Work-Based Learning 130
Definitions, IDAPA 09.01.01 148
Appeals Examiner 148
Claims for Wages Act 148
Department 148
Determination 148
Employment Security Law 148
Definitions, IDAPA 09.01.30 155
Additional Claim 155
Average Annual Wage 155
Average Weekly Wage 155
Central Claims Office 155
Chargeability Determination 155
Claim 155
Continued Claim 155
Corporate Officer 155
Fraud Overpayment 155
Full-Time Employment 156
Initial Claim 156
Interstate Claim 156
Intrastate Claim 156
Material 156
Monetary Determination 156
New Claim 156
Non-Fraud Overpayment 156
Non-Monetary Determination 156
Tolerance Amount 156
Definitions, IDAPA 09.01.35 178
Casual Labor 180
Domestic Employment 180
Exclusions From Wages 179
Tolerance Amount 178
Treatment of Limited Liability Companies 180
Wages 178
Willfully 180
Definitions, IDAPA 24.04.01 253
Geologist-in-Training 253
Registrant 253
Responsible Charge 254
Responsible Position 253
Definitions, IDAPA 31.41.01 285
Customer 285
Local Exchange Company (LEC) 285
Message Telecommunications Service (MTS) 285
Other Services 285
Residential Service 285
Small Business Telephone Service 285
Telephone Company 285
Definitions, IDAPA 37.03.01 306
Amendment Fee 306
Aquaculture 306
Aquaculture Fee 306
Claim 306
Department 307
Director 307
Domestic Use 307
Flat Fee 307
Late Fee 307
Per Acre Fee 307
Per CFS Fee 307
Per Kilowatt Fee 307
Public Entity 307
Public Purpose 307
State Law Claim Form 307
Stock Watering Use 307
Total Fee 307
Variable Fee 307
Water Delivery Organization 307
Water Delivery System 307
Definitions, IDAPA 37.03.02 319
Acre-Foot (af) 319
Acre-Foot/Annum 319
Amendment 319
Beneficial Use Examination (Examination) 319
Beneficial Use Examination Report (Examination Report) 319
Capacity Measurement 319
Certified Water Right Examiner (CWRE) 319
Conveyance Works 319
Cubic Foot Per Second (cfs) 319
Department 319
Director 319
Diversion Works 319
Duty of Water 319
Examination or Field Examination 320
Field Report 320
Headworks or Diversion Works 320
Irrigation 320
Legal Subdivision 320
License 320
License Examination Fee 320
Measuring Device 320
Nature of Use 320
Period of Use 320
Permit Holder or Owner 320
Permit or Water Right Permit 320
Place of Use (POU) 320
Point of Diversion (POD) 320
Project Works 320
Proof of Beneficial Use (Proof) 320
Source 321
Water Right Permit (Permit) 321
Definitions, IDAPA 37.03.03 332
Abandoned Well 332
Abandonment 332
Agricultural Runoff Waste 332
Applicant 332
Application 332
Aquifer 332
Beneficial Use 332
Best Management Practice (BMP) 332
Board 332
Casing 332
Cementing 333
Cesspool 333
Coliform Bacteria 333
Confining Bed 333
Construct 333
Contaminant 333
Contamination 333
Conventional Mine 333
Decommission (Abandon) 333
Deep Injection Well 333
Department 333
DEQ 333
Director 334
Disposal Well 334
Draft Permit 334
Drilling Fluid 334
Drywell 334
Endangerment 334
Exempted Aquifer 334
Existing Injection Well 334
Experimental Technology 334
Facility or Activity 334
Fault 334
Flow Rate 334
Fluid 334
Formation 334
Generator 334
Ground Water 334
Ground Water Quality Standards 335
Hazardous Waste 335
Improved Sinkhole 335

- Indian Lands 335
- Individual Subsurface Sewage Disposal System 335
- Industrial Wastewater 335
- Injection 335
- Injection Well 335
- Injection Zone 335
- IWRB 335
- Large Capacity Cesspools 335
- Large Capacity Septic System 335
- Maintain 336
- Modify 336
- Motor Vehicle Waste Injection Wells 336
- Municipal Wastewater 336
- New Injection Well 336
- Open-Loop Heat Pump Return Wells 336
- Operate 336
- Operator 336
- Owner or Operator 336
- Packer 336
- Perched Aquifer 336
- Permanent Decommission 336
- Permit 336
- Person 336
- Point of Beneficial Use 336
- Point of Diversion for Beneficial Use 336
- Point of Injection 337
- Pressure 337
- Radioactive Material 337
- Radioactive Waste 337
- RCRA 337
- Recycled Water 337
- Remediation Project 337
- Residential (Domestic) Activities 337
- Sanitary Waste 337
- Schedule of Compliance 337
- Septic System 337
- Shallow Injection Well 337
- Site 337
- State 337
- Stratum (plural strata) 337
- Subsidence 337
- Subsurface Fluid Distribution System 337
- UIC, Underground Injection Control 337
- Unauthorized Decommission 338
- Underground Injection 338
- Underground Source of Drinking Water (USDW) 338
- Unreasonable Contamination 338
- Wastewater 338
- Water Quality Standards 338
- Well 338
- Definitions, IDAPA 37.03.09 367
 - Annular Space 368
 - Approved Seal or Seal Material 367
 - Aquifer 368
 - Area of Drilling Concern 368
 - Artesian Water 368
 - Artificial Gravel Pack 368
 - Bentonite 368
 - Board 368
 - Bore Diameter 368
 - Borehole (also Well Bore and Boring) 368
 - Bottom Hole Temperature 368
 - Casing 368
 - Cathodic Protection Well 369
 - Closed Loop Heat Exchange Well 369
 - Conductor Pipe 369
 - Confining Layer 369
 - Consolidated Formations 369
 - Contaminant 369
 - Contamination 369
 - Decommissioned (Abandoned) Well 369
 - Decontamination 369
 - Department 369
 - Dewatering Well 370
 - Director 370
 - Disinfection 370
 - Draw Down 370
 - Drive Point (also known as a Sand Point) 370
 - Exploratory Well 370
 - Geotechnical Borings 370
 - Global Positioning System (GPS) 370
 - Hydraulic Conductivity 370
 - Hydraulic Fracturing 370
 - Injection Well 370
 - Intermediate String or Casing 370
 - Liner 371
 - Mineralized Water 371
 - Modify 371
 - Monitoring Well 371
 - Neat Cement 371
 - Neat Cement Grout 371
 - Oxidized Sediments 371
 - Perforated Well Casing 371
 - Pitless Adaptor or Pitless Unit 371
 - Potable Water 371
 - Pressure Grouting (Grouting) 371
 - Production String 371
 - Public Drinking Water System 372
 - Public Water System 371
 - Reduced Sediments 372
 - Remediation Well 372
 - Sand 372
 - Screen (Well Screen) 372
 - Seal or Sealing 372
 - Start Card 373
 - Static Water Level 373
 - Surface Casing 373
 - Temporary Casing 373
 - Thermoplastic/PVC Casing 373
 - Transmissivity 373
 - Tremie Pipe 373
 - Unconfined Aquifer 373
 - Unconsolidated Formation 373
 - Unstable Unit 373
 - Unusable Well 373
 - Waiver 373
 - Waste 373
 - Water Table 373
 - Well 374
 - Well Development 374
 - Well Driller or Driller 374
 - Well Drilling or Drilling 374
 - Well Owner 374
 - Well Rig (Drill Rig) 374
- Definitions, IDAPA 39.03.60 444
 - Commercial or Industrial Activities 444
 - Commercial or Industrial Zones 445
 - Erect 445
 - Grandfather Sign 445
 - Illegal Sign 446
 - Main Traveled Way 446
 - Multiple Message Sign (MMS) 446
 - Nonconforming Sign 446
 - Official Signs & Notices 446
 - Sign Face 447
 - Sign Structure 447
 - Transient or Temporary Activity 447
 - Unzoned Commercial or Industrial Area 448
 - Urban Areas 448
 - Visible 448
- Definitions, IDAPA 39.03.65 459
 - Traffic Minute Entries 459
- Denial, Restriction, & Termination of Service 292
- Denial, Restriction, Modification, Or Termination Of Long-Distance Service Or Other Services 296
 - Compliance 296
 - Failure to Pay 296
 - Loss of Services 296
- Depopulation Of Animals 59
 - Preventive Slaughter or Destruction 59
 - Scope of Depopulation 59
- Deposit Requirements -- LECs 286
 - Bankrupt Customers 287
 - Residential Customers 286
 - Small Business Customers 286
- Determination Of Fair Value Of Remuneration For Personal Services 190
- Determination Of Proper Quarter In Which To Assign & Report Wages 190
 - Awarded Damages Against Employers 190
 - Draws & Advances on Wages 190
 - Judgments of Wages 190
 - Wage Assignment to Proper

- Calendar Quarter 190
- Determination Of Reportable Quarters 190
- Determinations/Appellate Processes 161
 - Rebuttal Procedure 161
 - Reestablishing Eligibility After a Determination of Ineligibility 161
- Determining Pesticide Area Boundaries 36
 - Determining Boundaries 37
 - Pesticide Area Boundary Factors 36
- Determining Status Of Worker 183
 - Determining if Worker is an Employee 183
 - Determining if Worker is an Independent Contractor 183
 - Evidence of Contractual Liability for Termination 185
 - Meeting Criteria for Covered Employment 185
 - Proving Worker is Engaged in Independently Established Business 183
 - Proving Worker is Free From Control or Direction in His Work 183
- Diesel, Biodiesel, And Gasoline Standards 28
- Discharge 161
 - Burden of Proof 161
 - Disqualifying Misconduct 161
 - Inability to Perform or Ordinary Negligence 161
 - Indefinite Suspension 162
 - Non-Job Related Conduct 162
 - When Notice of Discharge Prompts a Resignation 162
- Disinfection Of Premises, Buildings & Vehicles 45
 - Disinfectants 45
 - Moving Contaminated Vehicle 45
 - Owner Responsibility 45
 - Supervision of Cleaning & Disinfection 45
 - Yards & Other Premises 45
- Dismissal If Filing Is Late 151
- Dismissal Of Wage Claims For Lack Of Prosecution 149
- Displays Located Within Zoned Or Unzoned Industrial, Business Or Commercial Areas 449
 - Dimensions 449
 - Lighting 451
 - Size of Signs 449
 - Spacing of Advertising Displays 449
 - Variable or Multiple Message Signs 451
- Disposition Of EIA Reactors 49
 - Duration of Quarantine 50
 - Quarantined 49
- Drawings, Map, & Schematic Diagram 327
 - Attachment Sheets 327
 - Drawings 327
 - Map 327
 - Photographs 327
 - Submittal 327
- Drilling Permit Requirements 390
 - Converting an Artificial Openings or Excavations Not Constructed as a Well for Use as a Well 391
 - Effect of a Permit 390
 - Exclusions 391
 - Fees 391
 - General Provisions 390
- Due Date Of Bills--Delinquent Bills 290
- Duration Of CWD Quarantine 74
 - Adjacent Herds 75
 - Complete Depopulation 75
 - CWD Positive Herds 74
 - CWD Suspect Herds 75
 - Disposal of Positive or Exposed Cervidae 75
 - Exposed Herds 75
 - Fencing Requirements 75
 - Source Herds & Herds of Origin 75
- E**
- Effect Of Delay or Error of Postal Service or Department 150
 - Decisions of the Appeals Examiner 151
 - Department Determinations 150
- EIA Is A Reportable Disease 49
- EIA Test Positive Animals Declared To Be Infected 49
- Election To Exempt Corporate Officers 182
 - Definitions 182
 - Election for Corporations that are not Public Companies 182
 - Election to Exempt Not Applicable 182
 - Public Company Election 182
 - Reinstatement of Coverage 182
 - Services in Employment 183
 - Termination of Exemption 182
- Eligibility 106
 - Academic Eligibility 106
 - Additional Eligibility Requirements 106
 - Financial Eligibility 106
- Employees Of Educational Institutions 162
 - Possibility of Employment 162
 - Reasonable Assurance 162
 - Reasonable Assurance Later Given 162
 - Retroactive Payments 162
 - Under Contract, But Between School Terms 162
- Employer Records
- Records to be Made
 - Available 181
 - Required Information 181
 - Travel or Employee Business Expenses 181
- Employer Status Report
 - Exceptions 181
 - Status Report 181
- Endorsements 122
 - Alternative Authorization - Teacher to New Endorsement 122
 - Clinical Experience Requirement 122
 - National Board Certification 123
- Epithelioma - Public Livestock Markets 47
- Equidae -- Equine Infectious Anemia 49
 - Blood Samples 49
 - Official Samples 49
 - Official Tests 49
- Eradication Methods 55
- Examination For Beneficial Use 322
 - Examination Report 322
 - Examination Report Acceptability 325
 - General 326
- Examinations 256
 - Authorization 256
 - Fundamentals of Geology 256
 - Practice of Geology 256
 - Reexamination 256
 - Re-Score or Review of Examination 257
 - Scores 257
 - Time & Place 257
- Exemption From Attorney General Administrative Procedure Rules For Contested Cases 148
- Exemptions Authorized By Section 40-1904, Idaho Code 449
 - Advertising Sale or Lease of Property 449
 - On-Premise Signs 449
 - Signs Erected by Public Officers or Agencies 449
- Exercise Of Rights By Customer 285
- Experience Rating - Qualifying Period 189
- Explanation For Denial Of A Service To A Customer 292
- Explanation For Denial Of Service Or Requirement Of Deposit -- LECS 287
- Exposed Equidae 50
 - Hold Order 50
 - Movement of Exposed Equids 50
- Exposure Of Anothers Animals Not Allowed 58
 - Housed 58
 - Turned Out 58
- Extended Benefits 163
 - Evidence of Employment for

- Extended Benefits 163
- Remuneration Earned 163
- Extended Validity Equine Certificates 50
- F**
- Fact 358
- Farm Commodity Ownership 186
 - Quantity 186
 - Wages 186
- Federally Protected Wildlife 205
- Fees 255, 263
- Field Operations Control 187
 - Execution Against Assets 188
 - Frequency of Audits 187
 - Limitation for Commencing Administrative Procedures 187
 - Notification of Audits 187
 - Relief of Indebtedness 188
- Final Reports 236
 - Change In Status Of Employer 236
 - Format 236
 - Report Requirements 236
- Financial Statements 22
 - Statement Compliance 22
 - Statement Content 22
- First Purchaser Rules 462
 - Designated Quarters 462
 - Late Payment Penalty 463
 - Oilseed Tax Invoice (Form Number 1) 462
- Fishing Methods & Gear 207
 - Fishing Shelters 208
 - Gaff Hook Exceptions 208
 - General Restrictions 207
 - Snagging, Archery, & Spear Exceptions 208
 - Trapping & Seining Exceptions 208
 - Use of Bait Exceptions 208
 - Use of Hands Exceptions 208
- Flat Fees 308
 - Domestic & Stockwater 308
 - Other Claims 308
- Foreign Animal & Reportable Diseases 50
 - Avian Diseases 51
 - Avian Chlamydiosis (Psittacosis) 51
 - Avian Influenza 51
 - Exotic Newcastle Disease 51
 - Bovine Diseases 51
 - Babesiosis 51
 - Bovine Brucellosis (B. abortus) 51
 - Bovine Spongiform Encephalopathy 51
 - Bovine Tuberculosis 51
 - Contagious Bovine Pleuropneumonia 51
 - Crimean Congo Hemorrhagic Fever 51
 - Lumpy Skin Disease 51
- Malignant Catarrhal Fever (Foreign Type) 51
- Rinderpest 51
- Trichomoniasis 51
- Cervidae Diseases 51
- Equine Diseases 52
- African Horse Sickness 52
- Contagious Equine Metritis 52
- Dourine 52
- Equine Encephalomyelitis (Eastern, Western, Venezuelan) 52
- Equine Infectious Anemia 52
- Equine Piroplasmosis (Babesiosis) 52
- Equine Viral Arteritis 52
- Glanders 52
- Hendra Virus 52
- Japanese Encephalitis 52
- Surra (Trypanosoma evansi) 52
- Fish Diseases 52
 - Asian Tapeworm of Carp 52
 - Oncorhynchus Masou Virus Disease 52
 - Spring Viremia of Carp 52
 - Viral Hemorrhagic Septicemia 52
- Lagomorph Diseases 52
- Multiple Species 50
- Anthrax 50
- Brucellosis 50
- Foot & Mouth Disease 50
- Heartwater 50
- Leishmaniasis 50
- Plague (Yersinia pestis) 51
- Pseudorabies 51
- Q Fever (Coxiella burnetti) 51
- Rabies 51
- Rift Valley Fever 51
- Scabies 51
- Screw Worms 51
- Theileriosis 51
- Trypanosomiasis 51
- Tuberculosis 51
- Tularemia 51
- Vesicular Stomatitis 51
- Sheep & Goat Diseases 52
- Contagious Caprine Pleuropneumonia 52
- Nairobi Sheep Disease 52
- Ovine Brucellosis (B. melitensis) 52
- Peste des Petits Ruminants 52
- Scrapie 52
- Sheep & Goat Pox 52
- Swine Diseases 52
- African Swine Fever 52
- Classical Swine Fever (Hog Cholera) 52
- Enterovirus Encephalitis (Teschen Disease) 53
- Nipah Virus Encephalitis 53
- Porcine Brucellosis (B. suis) 53
- Swine Vesicular Disease 53
- Form & Number Of Copies Of Price List Or Tariff 303
- Forwarding Agricultural Commodities 19
- Fully Employed/Not Unemployed 163
 - Corporate officer 163
 - Excessive Earnings Week 163
 - Leave of Absence 163
 - Suspension 163
- Further Definition -- Billing Statement 288
- G**
- Game Management Zone Descriptions 204
 - Bannock Zone 205
 - Bear River Zone 205
 - Beaverhead Zone 204
 - Big Desert Zone 205
 - Boise River Zone 205
 - Brownlee Zone 204
 - Diamond Creek Zone 205
 - Dworshak Zone 204
 - Elk City Zone 204
 - Hells Canyon Zone 204
 - Island Park Zone 205
 - Lemhi Zone 204
 - Lolo Zone 204
 - McCall Zone 204
 - Middle Fork Zone 204
 - Owyhee Zone 204
 - Palisades Zone 205
 - Palouse Zone 204
 - Panhandle Zone 204
 - Pioneer Zone 204
 - Salmon Zone 204
 - Sawtooth Zone 204
 - Selway Zone 204
 - Smoky - Bennett Zone 205
 - Snake River Zone 205
 - South Hills Zone 205
 - Tex Creek Zone 205
 - Weiser River Zone 204
- Garbage Feeding 54
 - Household Wastes 54
 - Inspection & Investigation 54
- General 308, 448
 - Control Requirement 448
 - Edge of Right-of-Way 448
 - Fire-Fighting 308
 - Government Voucher 308
 - Method of Payment 308
 - Multiple Sign Faces 448
 - Nonconforming Signs 448
 - Permit or License Revocation 448
 - Personal Check 308
 - Rejection of Claim 308
 - Requirement to Pay 308
 - Responsibilities 448
 - Signs Visible From the Main Travel-Way 448
 - Standards For Community Official Signs 454
 - Direction of Sign 454
 - Location of Sign 454
 - Size of Sign 455

- Time of Payment 308
 - Traffic Accident Memorials 453
 - Visible Informative Content 448
 - General Provisions 176, 413, 417, 459
 - Address Change 255
 - Certificates 254
 - Contribution Due Date 176
 - Contribution Reports 177
 - Dealer Title Fee Disclosure 413
 - Declared Business Hours 414
 - Determination of Payment
 - Date 177
 - Determinations & Appeals 176
 - Full Name Requirements 417
 - Idaho Consumer Asset Recovery (ICAR) Fund 413
 - Liability Insurance 414
 - Lien Interest 176
 - Penalties & Interest on
 - Bankruptcy 176
 - Penalty & Interest During Controversy 176
 - Physical or Electronic Records System Inspection 413
 - Preparation 459
 - Punctuation Marks 417
 - Quarterly Reporting 176
 - Release of Lien Upon Payment in
 - Full 177
 - Requests 459
 - Seals 254
 - Surety Bond 413
 - Temporary Regulations 459
 - Unresolved Differences 459
 - Vehicle Dealer License
 - Suspension 414
 - When Reports Replace Determinations 176
 - Geologist In Training 257
 - Limitation 257
 - Supervised Practice 257
 - Goat Assessments 103
 - Assessment as Resident Goats 103
 - Costs of Collection 103
 - Payment of Assessment 103
 - Granules (also Granular) 368
 - Ground Water Monitoring
 - Programs 36
 - Conduct Monitoring Programs 36
 - Evaluation 36
 - Monitoring Programs 36
 - Ground Water Quality Reference Points 34
 - HAL & RfD Guide 34
 - Reference Points 34
 - Grounds For Denial Or Termination Of A Service, Without Prior Notice 292
 - Customer Unable to Be Contacted 292
 - Dangerous Condition 292
 - Illegal Use of Services 292
 - Misrepresentation 293
 - Ordered to Terminate Service 292
 - Grounds For Denial Or Termination Of Local Exchange Service With Prior Notice 292
 - Customer Did Not Pay Undisputed Bills 292
 - No Obligation to Connect Service 292
- H**
- Health Standards 388
 - Distances From Contaminant Sources 388
 - Public Drinking Water System Wells 388
 - Special Standards for Construction of Wells When Mineralized or Contaminated Water Is Encountered 388
 - Hearing Before The IDAHO Water Resource Board 354
 - Hearings on Conditional Permits, Disapproved Applications, or Petitions for Exemption 354
 - Hearings on Permit Cancellations 354
 - Hearing Before The Water Resource Board 339
 - General 339
 - Hearings on Conditional Permits, Disapproved Applications, or Petitions for Exemption 339
 - Hearings on Permit Cancellations 339
 - High School Graduation Requirements 130
 - Civics & Government Proficiency 132
 - Content Standards 132
 - Credit Requirements 130
 - Foreign Exchange Students 133
 - Future Readiness Project 132
 - Localized Pathways 132
 - Middle School 132
 - Senior Project 132
 - Special Education Students 133
 - How Assessments Are To Be Calculated 24
 - Cash Sale or Credit Sale Contract 24
 - Incidental Costs & Expenses 24
 - Open Storage or Deposit for Service 24
 - Unpaid Assessments 24
- I**
- Idaho Consumer Asset Recovery Fund Control Board Administration 414
 - Actual Loss or Damages 414
 - Complete & Complaint Claims 414
 - Quorum 414
 - Voting 414
 - Idaho Educator Credential 113
 - Additional Renewal Requirements 120
 - American Indian Tribal Language Certificate 120
 - Career Technical Certification Requirements 117
 - Junior Reserved Officer Training Corps (Junior ROTC) Instructors 120
 - Postsecondary Specialist Certificate 120
 - Standard Administrator Certificate 116
 - Standard Instructional Certificate 113
 - Standard Pupil Service Staff Certificate 114
 - Idaho Electrical Code 277
 - Availability 280
 - Documents 277
 - Idaho Interim Certificate 121
 - Codes of Ethics 122
 - Idaho Comprehensive Literacy Course 121
 - Interim Certificate Not Renewable 121
 - Non-Traditional Route to Teacher Certification 121
 - Reinstatement of a Certificate Expired for One (1) Year or Less 121
 - Reinstatement of a Certificate Expired for Over One (1) Year 122
 - Teaching For Mathematical Thinking 121
 - Idaho Origin Sheep Interstate Grazing Permit 99
 - Identification Of Breeding Sheep and Goats 100
 - Acceptable Identification 101
 - Assignment of APHIS Approved Idaho Premises/Flock Identification Numbers 100
 - Identification Exemption 101
 - Importation Identification 100
 - Loss of Identification 100
 - Responsibility for Identification 100
 - Time of Identification 100
 - Identification Of EIA Reactors 50
 - Identification Of Exposed Swine 55
 - Importation Of Scrapie Exposed, Suspect & High Risk Animals Officially Identified 99
 - Valid Permit 99
 - Incorporation By Reference 27, 30, 65, 77, 92, 94, 127, 139, 214, 284, 332, 421
 - Local Availability 27
 - Required Reference Materials 27
 - Required Reference Materials for Checking Prepackaged Commodities 27
 - Specifications for Diesel Fuel and

- Biodiesel Fuel 27
 - Specifications for Gasoline 27
 - The Idaho Content Standards 127, 139
 - The Idaho Special Education Manual 128, 140
 - The Idaho Standards for Infants, Toddlers, Children, and Youth Who Are Blind or Visually Impaired 128, 139
 - The Idaho Standards for Infants, Toddlers, Children, and Youth Who Are Deaf or Hard of Hearing 128, 139
 - Three Year Tier Fee Table 27
 - Incorporation by Reference 192
 - Incorporation By Reference -- Code Of Federal Regulations 286
 - Incorporation By Reference, Subchapter A 42, 63, 81
 - The Association of American Feed Control Officials (AAFCO) Official Publication 81
 - The Merck Index 82
 - Incorporation By Reference, Subchapter B 56
 - Incorporation By Reference, Subchapter D 82
 - The Association of American Plant Food Control Officials (AAPFCO) Official Publication 82
 - The Association of Official Agricultural Chemists (AOAC) International 82
 - Incorporation By Reference, Subchapter E 82
 - The Association of American Plant Food Control Officials (AAPFCO) Official Publication 82
 - The Association of Official Agricultural Chemists (AOAC) International 82
 - Indemnification 102
 - Amount Of Indemnity to be Paid For Each Animal 102
 - Appraisals 102
 - Indemnity Payment Upon Approval of Appraisal 102
 - Indemnity Payments Paid 102
 - Maximum Amount of Indemnity 102
 - Owners, Individuals, Partnerships, Corporations or Other Legal Entities 102
 - Industrial Commission Review Of Appeals Examiner Decisions 153
 - Claim for Review Under the Employment Security Law 153
 - Transcripts 153
 - Informal Complaints & Interpretation Of Rules 286
 - Information To Customers 300
 - Required Information 300
 - When & How Information Provided 301
 - Information, Price Lists Or Tariffs For Non-Local Exchange Service 301
 - Information to be Filed 301
 - Service 302
 - Inspection Of Animals 46
 - Inspections 48
 - Inspecting Records 49
 - Scheduling of Inspections 48
 - Insufficient Grounds For Termination Of Local Exchange Service 294
 - Termination Prohibited 294
 - Insurance Deductible 23
 - Insurance Settlement, Commodities 22
 - Interest On Deposits 287
 - Interest Payable 287
 - Interest Rate 287
 - Interstate Shipments 100
 - Carriers, Permits 100
 - Waybill Requirement 100
 - Waybill Violation 100
 - Who May Inspect 100
 - Investigation Of CWD 74
 - Identification 74
 - Multi-Facility Ranches 74
 - Quarantine 74
 - Isolation Of EIA Reactors in Quarantine 50
 - Issuance Of Bills -- Contents Of Bills -- Residential & Small Business Service 289
 - Customer Request for Less Detail 289
 - Local Exchange Service 289
 - MTS Bills 289
 - Other Services 289
- J**
- Judicial Review Of Wage Claim Decisions 153
- L**
- Labor Dispute/Union Rules 163
 - Burden of Proving Nonparticipation 164
 - Involvement of Work Site in Labor Dispute 164
 - Lack of Work 164
 - Laid Off Before Labor Dispute 164
 - Period of Ineligibility 164
 - Picketing Work Site 164
 - Refusal to Cross Picket Line 164
 - Subsequent Employment 164
 - Termination of Labor Dispute 164
 - Union Member 164
 - Late Fees 310
 - Late Fee 310
 - Waiver 310
 - Legal Authority 16, 30, 41, 77, 94, 148, 155, 176, 192, 213, 253, 262, 284, 306, 318, 331, 367, 412, 421, 444, 459, 462
- Liberal Construction 218
 - License -- Duration, Bonded Warehouse Rules 23
 - License Application & Conditions Of Issuance 20
 - License Application 20
 - Modification 20
 - License Examination Fee 327
 - Examinations Conducted by Certified Water Right Examiners 328
 - Examinations Conducted by Department Staff 327
 - Licenses 451
 - Licensing 17
 - Bins Labeled 17
 - Insurance Calculations 17
 - Loss of License 17
 - Posting of License 17
 - Return of Suspended or Terminated License 17
 - Sign to be Posted 17
 - Suspension Due to Neglect 17
 - Licensure 254
 - Examination 254
 - Geologist-In-Training 254
 - Licensure & Registration 273
 - Continuing Education 274
 - Electrical Contractor & Limited Electrical Contractor 274
 - Journeyman Electrician 273
 - Limited Electrical Installer 274
 - Master Electrician 274
 - Residential Electrician 273
 - Lighting, Signs May Be Illuminated, Subject To The Following 456
 - Flashing or Moving Lights 456
 - Interference With Traffic Sign, Device, or Signal 456
 - Lights Which Impair Driver Vision 456
 - Livestock Identification Removal 46
 - Location 453
 - Incorporated Cities 454
 - Medians 454
 - Shoulder 454
- M**
- Maintenance 454
 - Management Plans Adopted By Rulemaking & Review 33
 - Adoption Through Rulemaking 33
 - PMP Review 33
 - Medical Facilities - Shelter Care 294
 - Medical Fees 238
 - Acceptable Charges For Medical Services Provided By Hospitals And Ambulatory Surgery Centers Under The Idaho Worker's Compensation Law 241
-

- Acceptable Charges For Medical Services Provided By Other Providers Under The Idaho Worker's Compensation Law 242
- Acceptable Charges For Medical Services Provided By Physicians Under The Idaho Worker's Compensation Law 239
- Acceptable Charges For Medicine Provided By Pharmacies 242
- Billing And Payment Requirements For Medical Services & Procedures Preliminary To Dispute Resolution 242
- General Provisions for Medical Fees 238
- Method Of Depopulation 59
- Miscellaneous Provisions 300
- Monitoring, Record Keeping, and Reporting Requirements 352
- Monitoring 352
- Permit Assignable 354
- Record Keeping 353
- Reporting 353
- Movement Of Restricted Animals 101
- Consigned Directly to Approved Destination 101
- Indelibly Marked 101
- Individually Identified on Approved Document 101
- Movement Or Sale Of Animal Products 58
- N**
- New Claims/Additional Claims 164
- Additional Claim or Reopened Claim 166
- Claims for Benefits, Delayed Filing 164
- Effective Date of Backdated Claims 164
- Filing of New Claims, Additional, and Reopen Claims 164
- Registration/Reporting Requirements - Interstate Claimants 165
- Requirement to Provide Information 165
- Separation Notice 165
- Use of Wage Credits 166
- Valid Claim 166
- No Price Established (NPE) Contract Claims On The Fund 25
- NPE Clause 25
- NPE Contract Renewal Period 25
- PE Contract List 25
- Notifiable Diseases 53
- Avian Diseases 53
- Avian Mycoplasmosis (*M. gallisepticum* and *M. synoviae*) 53
- Fowl Typhoid (*Salmonella gallinarum*) 53
- Pullorum Disease (*Salmonella pullorum*) 53
- Bovine Diseases 53
- Hemorrhagic Septicemia (*Pasteurella multocida*) 53
- Malignant Catarrhal Fever (Sheep Associated) 53
- Equine Diseases 53
- Equine Herpesvirus Myeloencephalopathy 53
- Equine Rhinopneumonitis 53
- Fish Diseases 53
- Epizootic Hematopoietic Necrosis 53
- Infectious Hematopoietic Necrosis 53
- Whirling Disease 53
- Lagomorph Diseases 53
- Mixed Species Diseases 53
- Sheep & Goat Diseases 53
- Bluetongue 53
- Caprine Arthritis/Encephalitis (CAE) 53
- Caseous Lymphadenitis 53
- Contagious Agalactia (*Mycoplasma* spp.) 54
- Enzootic Abortion (*Chlamydia psittici*) 54
- Footrot 54
- Haemonchus contortus* (drug-resistant) 54
- Johnes Disease 54
- Maedi-Visna/Ovine Progressive Pneumonia (OPP) 54
- Ovine Epididymitis (*Brucella ovis*) 54
- Toxoplasma gondii* Abortion 54
- Vibrionic Abortion (*Campylobacter fetus*) 54
- Swine Diseases 54
- Porcine Reproductive and Respiratory Syndrome (PRRS) 54
- Transmissible Gastroenteritis 54
- Notification Of Broken Seals 46
- Noxious Weeds - Designations 84
- Designation of Articles Capable of Disseminating Noxious Weeds 87
- Statewide Containment Noxious Weed List 86
- Statewide Control Noxious Weed List 85
- Statewide EDRR Noxious Weed List 84
- Statewide PROHIBITED GENERA Noxious Weed List 84
- NPIP Certificates Of Participation 49
- Inspection Forms 49
- Records 49
- Nutrient Management Records 68
- Land Application 68
- Manure Transferred to Another Person 68
- O**
- Office Records 19
- Daily Position Record 19
- Electronic Records 19
- Insurance Documentation 19
- Receipts & Tickets 19
- Receipts & Tickets Issued by Warehouseman 19
- Receipts & Tickets Returned & Cancelled 19
- Scale Weight Tickets 19
- Storage Ledger 19
- Official Livestock Identification Identification Tattoos 47
- Official Identification Tags 47
- Official Vaccination Tags 47
- Trichomoniasis Tags 47
- Official Vehicle For Approving Educator Preparation Programs 125
- Continuing Approval 125
- Non-Traditional Educator Preparation Program 125
- Payment Responsibilities for Educator Preparation Program Reviews 125
- The Official Vehicle for the Approval of Traditional Educator Preparation Programs 125
- Opportunity Scholarship Award 108
- Duration 108
- Eligibility 108
- New Scholarships for Community College 108
- Payment 108
- Order Of Selection 465
- Employment Maintenance 466
- Order of Selection 465
- Priority Status 466
- When Unable to Serve Eligible Individuals 466
- Other Deposit Standards Prohibited 287
- Outdoor Advertising Permits 452
- Advertising Illegal Activities 453
- Appeal Process 453
- Application 452
- Application Forms 452
- Cancellation of Permit 453
- Expiration of Annual Permits 452
- Invalid Permit 452
- Lost or Destroyed Identification Tags 452
- Modified Advertising Structures 452
- Permit Denial 452
- Physically Connected Signs 452
- Revoked Permits 453
- Space Requirement Violations 452
- Standard Permit Application 452
- Owners Responsibilities For Well Use & Maintenance 388

- Maintain All Other Separation
 - Distances 389
 - Maintenance 388
 - New Construction 389
 - Unusable Wells 389
 - Use 388
 - Wells Posing a Threat to Human Health and Safety or Causing Contamination of the Ground Water Resource 389

 - P**
 - Pardon 468
 - Application 468
 - General 468
 - Hearing 469
 - Parking On State Highways Within Cities 460
 - Partial Payments Of Amounts Owed The Department 173
 - Fraud Overpayments 173
 - Interest 173
 - Nonfraud Overpayments 173
 - Penalties 173
 - Payment Arrangements 295
 - Application of Payment 295
 - Arrangements Allowed 295
 - Reasonableness 295
 - Second Arrangement 296
 - When Arrangement Not Binding 296
 - Payments To The Department 148
 - Paytelephone Emergency Access Required 299
 - Access to Emergency Services 299
 - Emergency Dialing Instructions 299
 - Termination of Service for Violation of This Rule 299
 - Penalties 391, 415
 - Penalties For Failure To Collect, Account For, Or Remit Assessments 25
 - Penalty 328
 - Failure to Submit 328
 - Permits for Which Proof Has Not Been Submitted 328
 - Permits 98
 - Certificates of Veterinary Inspection to be Furnished 98
 - Examination & Treatment Fees 99
 - Inspection Fees 99
 - Request for Permits 98
 - Pesticide Use & Record Keeping Requirements 39
 - Physical Requirements 453
 - Memorial Site 453
 - Shape & Color 453
 - Poultry & Ratites 48
 - Release of Live Birds 48
 - Sale of Live Birds or Hatching Eggs 48
 - Practice Standards 254, 274
 - Certification & Approval of Electrical Products & Materials 277
 - Connecting & Energizing Prior to Inspections 275
 - Contractor Scope 274
 - Electrical Contracting Work 274
 - Limited Electrical Installations 275
 - Supervision 274
 - Price Lists Or Tariff Filings 302
 - Changes to Price Lists or Tariffs 303
 - Price Lists or Tariffs 302
 - Tracking Price Lists or Tariffs 303
 - Procedures 419
 - Document Approval by the Department 419
 - Surrendering Driver's License or Identification Card 419
 - Surrendering Duplicate Driver's License or Identification Cards 419
 - Verification of Name 419
 - Professional Athletes Between Seasons 167
 - Base Period Wages 167
 - Reasonable Assurance 167
 - Substantially All Services 167
 - Professional Employer Organizations Combined Wages or Services for Purposes of Coverage 187
 - Joint Transfer of Experience Rate 187
 - Methods of Reporting 186
 - Partial Reporting of Workers 187
 - Partial Transfers of Experience Rate Prohibited 187
- Pseudorabies
 - Procedures For Control & Eradication 54
 - Laboratories 54
 - Quarantines 55
 - Supervision 54
 - Pseudorabies – Procedures For Control & Eradication
 - Identification of Infected & Exposed Swine 55
 - Sale of Infected Animals 55
 - Vaccine 55
 - Public Notice 301
 - Public Records Act Compliance 31
 - Purpose 412, 417, 421, 444, 459
- Q**
- Qualification, Examination & Appointment Of Certified Water Right Examiner 321
- Consideration 321
- Denial 321
- Examinations 322
- Expiration 321
- Information 321
- Ingress or Egress Authority 322
- Liability 322
- Money Received 322
- Reconsideration 322
- Refusal or Revocation 322
- Reports 322
- Qualified Pseudorabies-Negative Herds 55
- Quality Of Service 298
 - Service Outage 298
 - Service Standards 298
- Quality of Service 298
- Quarantine 101
- Quarantine Area 58
- Quarantine Area Bio-Security 58
- Personnel 58
- Vehicles & Equipment 58
- Quarantine Area Security 58
- Quarantine Authority 57
- Quarantine Procedures For An Animal Health Emergency 57
- Quarantine Release 57
- Validity of Quarantine 57
- Written Notice 57
- Quarantine, Subchapter A 45
 - Acknowledgment of Quarantine 45
 - Disposition of Quarantined Animals 45
 - Hold Order 45
 - Written Notice 45
- Quit 166
 - Burden of Proof 166
 - Cause Connected With Employment 166
 - Good Cause 166
 - Moral or Ethical Quit 166
 - Quit Due to Harassment 167
 - Quit Due to Health or Physical Condition 166
 - Quit for Permanent Work or Quit Part-Time Work for Increase in Work Hours 166
 - Quit or Retirement During Employer Downsizing 167
 - Unrelated Discharge Prior to Pending Resignation 167
 - When Notice of Resignation Prompts a Discharge 167
- R**
- Rabies 48
 - Discharging Authority 48
 - Reporting 48
- Reasons For Exemption From Attorney General's Administrative Procedure Rules 149
 - Appeals Heard By Appeals Examiners 150
 - Claims for Wages Proceedings 149
 - Determinations and Time for

- Filing Appeals 150
- Unemployment Insurance Benefits and Tax Contribution Proceedings 149
- Receipting 17
 - Agreements 18
 - Change in Provider 18
 - Electronic Warehouse Receipts 18
 - Every Warehouseman 17
 - Form of Nonnegotiable Warehouse Receipts 17
 - Lost Negotiable Warehouse Receipt 17
- Record Of Complaints 298
- Recordkeeping 298
- Reporting 298
- Record Requirements, Poultry & Ratites 48
- Recordkeeping & Payment Schedule 24
 - Notice 24
 - Payment of Assessment by Mail 24
 - Permanent Record 24
- Records Of Deposits 288
 - Receipts 288
 - Retention of Records 288
 - Transfer of Records 288
- Recoveries 173
- Refund Applications 463
 - Assessment Refund 463
 - Refund Application Form Number 2 463
- Refunds 310
- Refusal Of Work/Failure To Apply 167
 - Citizenship or Residency Requirements 167
 - Claimant Conduct 168
 - Claimant Responsibility 168
 - Conscientious Objection 168
 - Employer Requirements 168
 - Failure to Report 168
 - Failure to Return to Work After Layoff 168
 - Government Requirements 168
 - Moral Objections 168
 - Offer of Work 168
 - Part-Time Work 168
 - Personal Circumstances 168
 - Prospect of More Suitable Work 168
 - Suitable Work 168
 - Travel Distance 168
- Registration 262
 - Additional Qualifications for Registration 262
- Reissuing Benefit Payments 168
 - Affidavit for Issuance of New Benefit Payment 169
 - Reissuance of Stolen Benefit Payments 169
- Rejected & Returned Claims 316
 - Refiled Claims 316
 - Rejected Claims 316
- Remuneration Paid Constitutes Both Taxable Wages & Excluded Amounts 181
- Repair Service Standards 299
 - Compliance Standard 299
 - Extenuating Circumstances 299
 - Restoration of Service 299
- Repealing Specific Pesticide Areas 37
 - Repealing an Area of Pesticide Concern 37
 - Repealing an Area of Pesticide Restriction 38
 - Repealing an Area of Pesticide Use Prohibition 38
- Reportable Income 169
 - Back Pay or Disputed Wages 169
 - Disability Retirement Payments 169
 - Disability/Injury Compensation 169
 - Gratuities or Tips 169
 - Holiday Pay 169
 - Non-Periodic Remuneration 169
 - Penalty or Damage Awards 169
 - Pension, Retirement, or Annuity Payments 169
 - Relief Work or Public Assistance 169
 - Severance Pay 170
 - Temporary Disability Benefits 170
 - Vacation Pay 170
 - Verification of Earnings on Claim Reports 170
 - Wages for Contract Services 170
 - Wages for Services Performed Prior to Separation 170
- Reporting Requirements 170
 - Electronic Mail Reports 170
 - Facsimile Reports 170
 - Internet Reports 170
 - Mailed Reports 170
 - Telephone Reports 170
 - When Report Missing 171
- Request For Telephone Company Records 301
 - Exceptions 301
 - General Rule 301
- Required Entries 459
 - Limits 460
 - Other Entries 460
 - Parking 460
 - Traffic Control 460
- Requirements For Laboratory Alcohol Analysis 194
 - Appeal 195
 - Blood Collection 195
 - Blood Reported 195
 - Blood Samples 195
 - Laboratory 194
 - Records 195
 - Urine Collection 195
- Urine Reported 195
- Requirements For Maintaining Idaho Worker's Compensation Claims Files 226
 - Access Card Payments 228
 - Audits 231
 - Checks & Drafts 230
 - Claim Files 226
 - Compensation Payments - Generally 227
 - Copies of Checks 230
 - Correspondence 226
 - Date Stamp 226
 - Electronic Transfer Payments 227
 - Idaho Office 226
 - Non-Compliance 231
 - Notice & Claim 226
 - Prompt Claim Servicing 230
- Requirements For Notice Before Termination Of Local Exchange Service 293
 - Additional Notice 293
 - Failure to Pay 293
 - Final Notice 293
 - Initial Notice 293
- Requirements For Performing Breath Alcohol Testing 195
 - Administration 196
 - Deficiencies 198
 - Instruments 195
 - Minor in Possession or Minor in Consumption (MIP/MIC) 198
 - Performance Verification Checks 197
 - Records 198
 - Report 196
 - Standards 198
 - Training 197
- Residential & Small Business Deposit Practices 286
- Response To A Pesticide Detection 34
 - Level Four Response 36
 - Level One Response 34
 - Level Three Response 35
 - Level Two Response 35
 - Mixing & Loading Prohibited 36
 - Prohibition Areas 36
- Response To Service Outage 298
 - Receipt & Recording of Reports 298
 - Repair Commitments 299
- Responsibilities Of Eligible Idaho Postsecondary Educational Institutions 109
 - Adult Learner Evaluation 109
 - Other Requirements 109
 - Statements of Continuing Eligibility 109
- Responsibility For Payment Of Residential Service Bills 291
 - Contents of Notice 291
 - Customer Defined 291
 - Customer Notice 291
 - Customer's Responsibility 291

- Opportunity to Respond 291
 - Restriction Of High-Risk Animals 101
 - Restrictions On Animals From Areas Or States Affected By Emergency Diseases 58
 - Restrictions On Termination Of Local Exchange Service--Opportunity To Avoid Termination Of Local Exchange Service 295
 - No Termination While Complaint Pending 295
 - Personnel to Authorize Reconnection 295
 - Service to Persons Not Customers 295
 - When Termination Not Allowed 295
 - Return Of Commodity Due To Failure 25
 - Return of Commodity Due To Failure Fungible Commodity 25
 - Identifiable Commodity 25
 - Shortfall in Commodity Distribution 25
 - Return Of Deposit -- LECS 287
 - Early Return of Deposit 288
 - Existing Customers 287
 - Former Customers 287
 - Retention During Dispute 288
 - Review By Commission Rights Protected 298
 - Rounding Wages Reported On Contribution Report To Next Lower Dollar Amount 178
 - Rule Governing 72-212(5) Exemptions 218
 - Approval by Commission 218
 - Effective Date 218
 - Exemption Effective 219
 - Exemptions 218
 - Form 218
 - IC53 Form 218
 - Rule Governing Approval Of Attorneys Fees 237
 - Charges Presumed Reasonable 237
 - Disclosure Statement 238
 - Procedure if Fees Are Determined Not to Be Reasonable 238
 - Purpose 237
 - Statement of Charging Lien 237
 - Rule Governing Average of Multiple Impairment Ratings 233
 - Averaging Multiple Ratings 233
 - Correcting Manifest Injustice 233
 - Rule Governing Change Of Status Notice To Claimants 236
 - By Whom Given 236
 - Copies of Notice 237
 - Form of Notice 236
 - Medical Reports 237
 - Notice of Change of Status 236
 - Rule Governing Compensation For Disability Due To Loss Of
 - Teeth 233
 - Compensation for Disability 233
 - Prima Facie Evidence 233
 - Rule Governing Computation Of Average Weekly Wage 232
 - Amounts Paid over Base Rate 232
 - Examples Not Exclusive 233
 - Fringe Benefits 232
 - Premium Pay 232
 - Rule Governing Conversion Of Impairment Ratings To "Whole Man" Standard
 - Converting Single Rating of Body Part to Whole Person Rating 233
 - Rule Governing Premium Tax Computation For Self-insured Employers 225
 - Experience Modification 225
 - Payroll Reports 225
 - Rule Governing Protection & Disclosure Of Rehabilitation Division Records 234
 - Request for Disclosure 235
 - Requests from Other Agencies 235
 - Rule Governing Reimbursement For Travel Expenses 234
 - Commercial Transportation 234
 - Frequency of Requests 234
 - Mileage Rate 234
 - Request for Reimbursement 234
 - Rule Governing Reporting Indemnity And Medical Payments And Making Payment Of Industrial Special Indemnity Fund (ISIF) Assessment 232
 - Rule Governing Reporting Indemnity And Medical Payments And Making Payment Of Industrial Special Indemnity Fund Assessment
 - Adjustment for Overpayments or Underpayments 232
 - Estimating Indemnity Payments for Entities That Fail to Report Timely 232
 - Filing 232
 - Form 232
 - Penalty for Late Filing 232
 - Report Required When No Indemnity Paid 232
 - Rule Governing Reports Of Attorney Costs & Fees In Litigated Cases 235
 - Rule Governing The Collection Of Premium Tax On Worker's Compensation Insurance Policies 225
 - Procedure for Submitting Premium Tax Forms 225
 - Rule Prohibiting Use Of Sick Leave Or Other Alternative Compensation 231
 - Election of Sick Leave or Alternative Compensation
 - Prohibited 231
 - Employee Not Required to Take Sick Leave in Lieu of Compensation 231
 - Rules Governing Continuing Requirements To Underwrite Insurance Or Self-Insure 221
 - Insurance Carriers 221
 - Self-Insured Employers 223
 - Rules Governing Qualifications To Write Insurance Or Self-Insure 219
 - Insurance Carriers 219
 - Self-Insured Employers 220
- S**
- Safety 454
 - Parking 454
 - Participants & Motorists 454
 - Sale Of Diseased Or Exposed Animals Not Allowed 58
 - Samples For Official Regulatory Tests 45
 - Accredited Veterinarians 45
 - Persons Approved by the Administrator 45
 - State or Federal Animal Health Officials 45
 - Scabies, Sheep & Goats Entering Idaho 99
 - Scope 16, 30, 41, 65, 77, 94, 148, 155, 176, 192, 253, 262, 284, 306, 318, 331, 367
 - Examination Requirements 318
 - Rules 318
 - Scrapie Infected Flock 97
 - Scrapie Program Standards, Scrapie Flock Certification, Scrapie Control & Eradication 100
 - Scrapie Source Flock 97
 - Scrapie-Positive Animal 97
 - Seeking Work 171
 - Attitude & Behavior 171
 - Effort to Secure Employment 171
 - Employer's Hiring Practices 171
 - Job Attachment
 - Classifications 171
 - Jobs Availability 171
 - License or Permits 171
 - No Employment Prospects 171
 - Seasonal Availability 171
 - Work-Seeking Requirement Categories 171
 - Selection Of Scholarship Recipients 107
 - Monetary Value of the Opportunity Scholarship 107
 - Selection Process 107
 - Self-Employment 173
 - Occupational Conflicts 173
 - Potential Employability 173
 - Serious Illness Or Medical Emergency 294
 - Medical Certificate -- Postponement of Termination of

- Local Exchange or MTS Services 294
 - Obligation to Pay 294
 - Restoration of Service 294
 - Second Postponement 294
 - Verification of Medical Certificate 294
 - Services Performed Part In Covered Employment & Part In Excluded Employment 183
 - Severity Of Disability 465
 - Priority Category 1 - Eligible Individuals with the Most Significant Disabilities (MSD) 465
 - Priority Category 2 - Eligible Individuals with Significant Disabilities (SD) 465
 - Priority Category 3 - All other Eligible Individuals with Disabilities (D) 465
 - Sheep & Goat State Entrance Requirements 98
 - Brucella Ovis 98
 - Entrance Requirements 98
 - Sheep Assessments 103
 - Assessment as Resident Sheep 103
 - Costs of Collection 103
 - Migratory Sheep 103
 - Payment of Assessment 103
 - Signatures Of Illiterates & Witnesses 173
 - Slamming Provisions 303
 - Slaughtering Of Diseased Animals 46
 - Authorized by Law 46
 - Not Authorized by Law 46
 - Snake River Quarantine 90
 - State and County Watercraft 90
 - Special Education 133, 140
 - Assistive Technology Devices 137, 144
 - Definitions 133, 140
 - Adult Student 133, 140
 - Due Process Hearing 133, 140
 - Education Agency 133, 140
 - Idaho Special Education Manual 133, 140
 - Special Education 133, 140
 - Diplomas & Graduation 137, 144
 - Eligibility for Special Education 135, 141
 - Individualized Education Programs 135, 141
 - Legal Compliance 134, 140
 - Procedural Safeguards 136, 142
 - Special Education Advisory Panel 137, 144
 - Standards For Directional Signs 455
 - Message Content 456
 - Prohibited Directional Signs 455
 - Size of Directional Signs 455
 - Spacing of Directional Signs 455
 - Standards For the Quality of Fluids
 - Injected into Class V Wells 350
 - Biological contaminants 350
 - Chemical and Radiological Contaminants in Injected Fluids 350
 - General 350
 - Injectate Standards for the Quality of Recycled Water Derived from a Municipal or Industrial Wastewater Source 351
 - Physical, Visual, and Olfactory Characteristics 351
 - Standards for the Quality of Fluids Injected to Subclass 5A7 Wells (Open-Loop Heat Pump Return) 351
 - Waivers 350
 - State & Federal Seals 46
 - Persons Designated by the Administrator 46
 - State or Federal Animal Health Officials 46
 - State Animal Health Official 97
 - State Procedures 303
 - Form 303
 - Procedure 304
 - Status 186
 - Employer Quarterly Report Forms 186
 - Notification to Liable Employers 186
 - Status Information Required 186
 - Update Requirements 186
 - Submission Of FROI & SROI 235
 - EDI Reporting 235
 - Filing Considered
 - Authorization 236
 - Filing Not an Admission 235
 - Purpose 235
 - Report Form & Content for Parties Exempt from EDI Requirements 235
 - Retaining Claims Files 235
 - Timely Response Requirement 236
 - Trading Partner Agreements 235
 - Submission Of Medical Reports From Providers 233
 - Forfeiture of Payment 234
 - Procedure 233
 - Report Form & Content 234
 - Timely Response Requirement 234
 - Substance VS. Form 180
 - Sufficiency Of Claims 310
 - Claim Form 310
 - Further Information 315
 - Insufficient Claims and Waivers 315
 - Minimum Requirements 311
 - Single Claim 310
 - Supplemental or Subsequent Report of Injury (SROI) 217
 - Surveillance For CWD 73
 - Enhanced Surveillance 74
 - Routine Surveillance 73
 - Swine Cleaning & Disinfection 55
- T**
- Telephone Company Response To Informal Complaints 298
 - Telephone Solicitations 301
 - Time Limit For Appraisal 59
 - Time Limit For Depopulation 59
 - Title & Scope 213, 421
 - Rule Coverage 331
 - Scope 331, 412
 - Title 331, 412
 - Variance of Methods 331
 - Total Temporary Disability Alternate Base Period (TTD) 173
 - Traffic Accident Memorial Permit 453
 - Written Approval from the Next of Kin 453
 - Written Approval from the Property Owner 453
 - Transfer Of Deposit and Outstanding Balance 288
 - Transfer Of Experience Rating
 - Continued Predecessor Employment for Liquidation 188
 - Management or Ownership or Control Substantially the Same 189
 - Mandatory Transfer of Rate 188
 - Partial Experience Rate Transfers 188
 - Wage Paid by Predecessor 189
 - Transit Inspection, Animal Industry 45
- U**
- Unauthorized Change Of A Customer's Telephone Company 303
 - Unclaimed Deposits & Advance Payments 288
 - Financial Assistance Program 288
 - Presumption of Abandonment 288
 - Use of Bait by a Grizzly Bear 210
 - Utilization Of Vaccination In Animal Health Emergencies 57
- V**
- Vaccinated Swine 55
 - Variable Fees 308
 - Claims Including Storage 309
 - Exceptions 310
 - General 308
 - Multiple Purpose Claims 310
 - Per Acre Fee 309
 - Per CFS Fee 309
 - Per Kilowatt Fee 309
 - Variance 78
 - Procedure for Seeking a Variance 78
 - Submission of Variance 78
-

Support & Withdrawal of
Petitions 78
Violations 103
Violations, Formal Notification &
Enforcement 338
 Additional 339
 Enforcement 339
 Formal Notification 339
 Violations 338
Violations, Formal Notification And
Enforcement 354
 Additional 354
 Enforcement 354
 Violations 354

W

Wage Claim & Employment Security
Law Determination
 Computation of Time 150
Wage Claim & Employment Security
Law Determinations 150
Wage Claims Procedures 149
Waiver Of Repayment 174
Warehouseman Responsibilities 21
 Rights & Duties of Warehouse
 Licensees -- Unlawful
 Practices 21
 Warehouse Receipts -- Quality 21
Warehouses To Be Kept Clean 20
Wastewater Storage & Containment
Facilities 67
 All Substances Entering
 Wastewater Storage &
 Containment Facilities 68
 Wastewater Storage &
 Containment Facilities 67
Water Measurement 326
 Diversion Rate 326
 Measurement 326
 Measurements 326
 Method 327
 Unacceptable Measurements 327
Written Interpretations 30
 EDI Guide and Tables 214
 EDI Implementation Guide 214
Written Interpretations – Agency
Guidelines 284